



OM 230V/50Hz



Dimensions:

Grâce à un corps de pompe en plastique dont la teneur en fibre a été légèrement renforcée (FRP) et à une couverture supérieure, la pompe peut résister à l'abrasion et à la corrosion et nécessite ainsi moins d'entretien. La turbine vortex permet d'éliminer les blocages et l'agglutination de solides. Fabriquée à base de FRP, elle résiste à une longue utilisation avec un degré d'usure minimum.

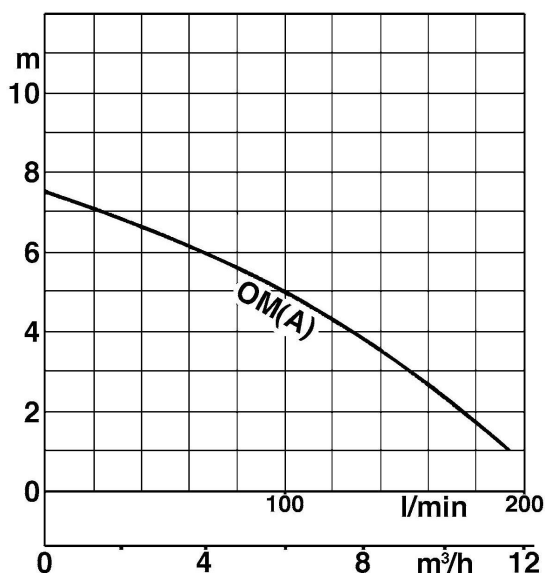

∅ refoul. mm	Modèle	Puiss. Moteur kW	Phase	HMT maxi m	Débit maxi l/min	Passage Turbine mm	Câble m
32	OM(A)	0,15	mono	7,5	195	10	10

Caractéristiques OMA2

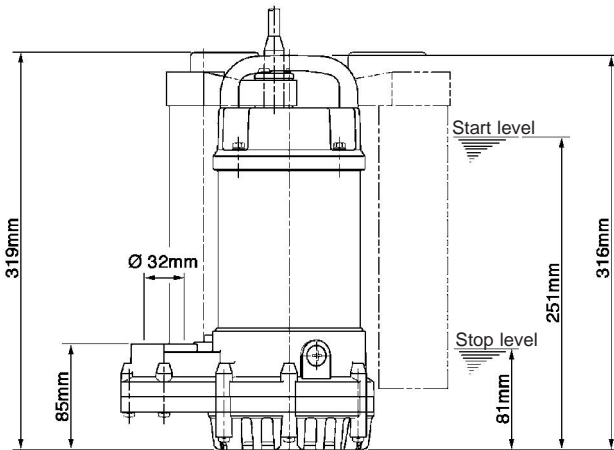
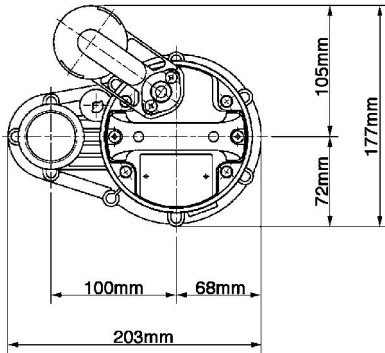

OMA2 (A-14082-1)

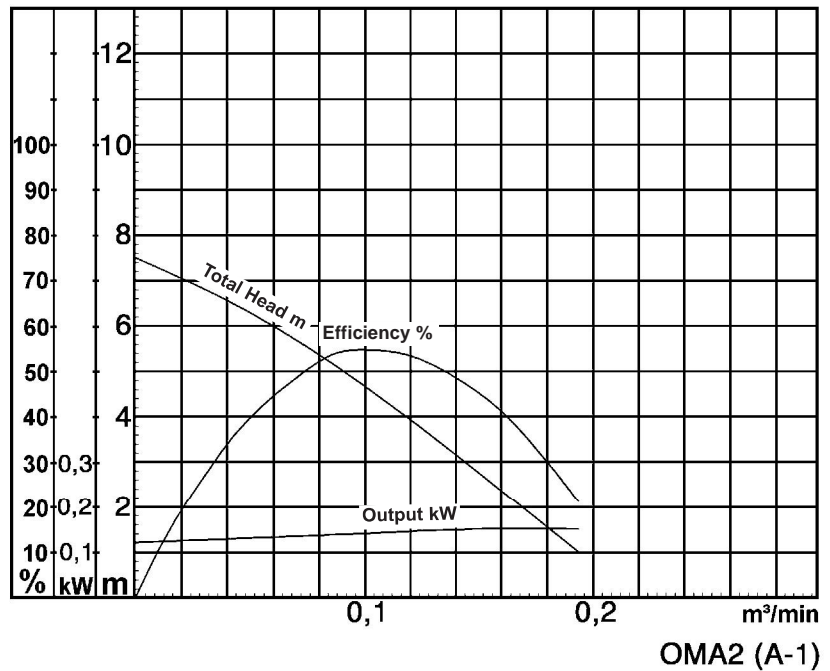

Classification

Electric submersible pump
 Protection class IP68
 Depth of submersion max. 20m
 Vortex impeller
 Impeller passage 10mm
 Suitable for sewage water, various waste water

Electric Motor

Dry-type submersible induction motor,
 Insulation class E, 2 poles, 2850 r.p.m.
 Capacitor start
 Voltage: 110/230V, 50Hz, 1-phase
 Power input: 0,30kW
 Power output: 0,15kW
 Nominal current: 3,1A/1,6A
 Start current: 8,1A/4,3A

Electric Cable

10m H07RN-F 3Cx1mm²

Motor Protection

Circle thermal protector
 (snap-action bi-metal device)

Shaft Seal

Double mechanical seal in oil bath
 Primary Seal:
 silicon carbide on silicon carbide
 Secondary Seal:
 ceramic on carbon

Bearings

Shielded ball bearings, maintenance-free

Materials

Impeller:	Fibre reinforced plastic
Casing upper:	Fibre reinforced plastic
Casing lower:	Fibre reinforced plastic
Motor frame:	SUS304 (EN-X5CrNi18-10)
Shaft:	SUS403 (EN-X6Cr13)

Discharge Connection

1,25" (32mm) screwed-in mating flange

Weight

6,1 kg (dry weight of the pump)

Special Feature

Level control by float switch

Dimensional Drawing OMA2

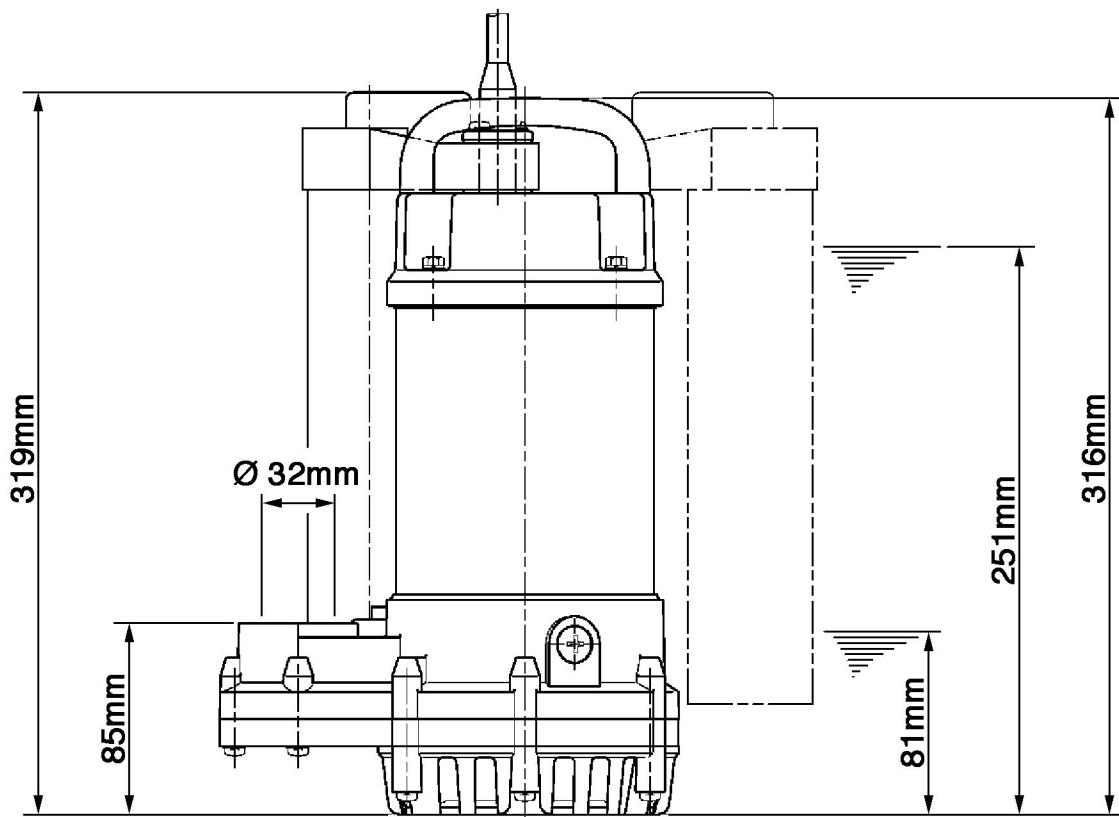
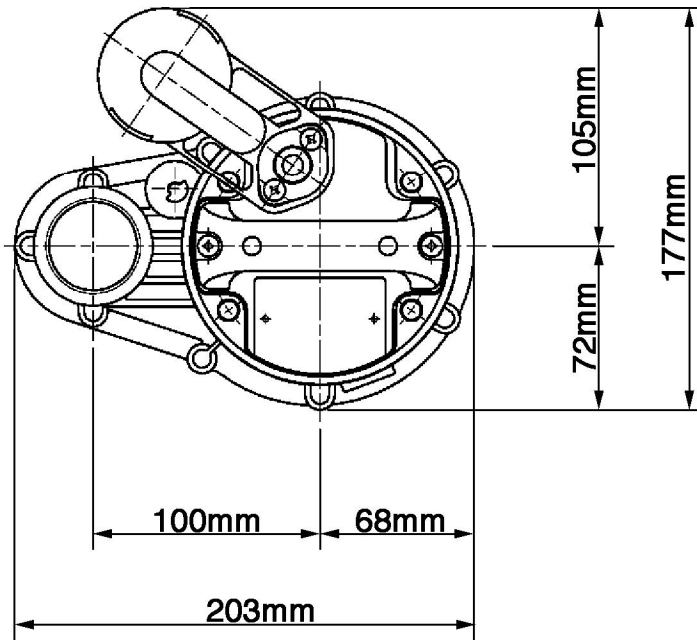

OMA2 (A-14082-1)

Sectional Drawing OMA2

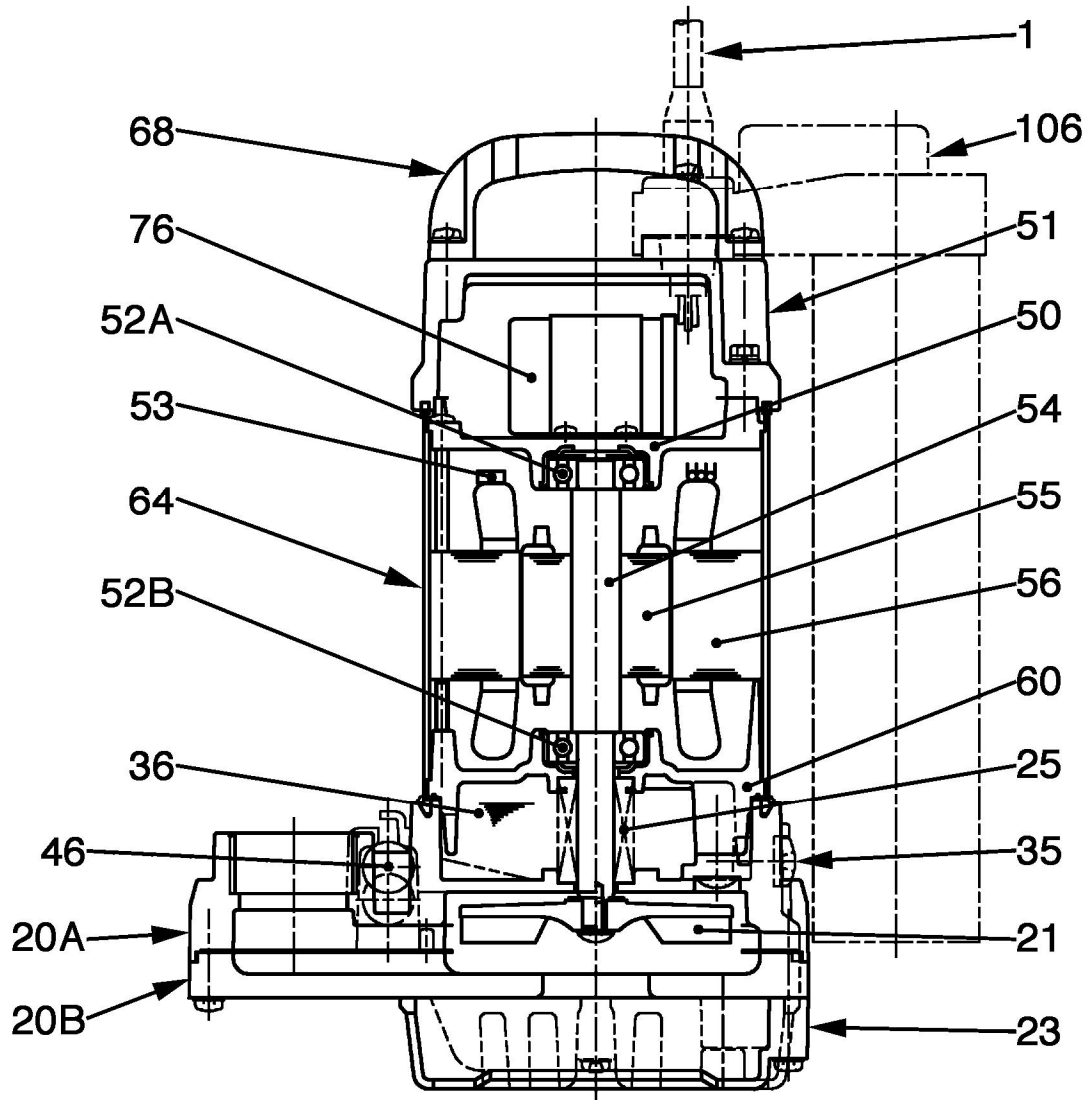

OMA2 (A-14083-1)

No.	Description	Qty.	Remarks	No.	Description	Qty.	Remarks
1	Cabtyre Cable	1	H07RN-F	54	Shaft	1	SUS403 (EN-X6Cr13)
20A	Casing Upper Half	1	Plastic W/GF	55	Rotor	1	
20B	Casing Lower Half	1	Plastic W/GF	56	Stator Complete	1	
21	Impeller	1	Plastic W/GF	60	Bearing Housing	1	Aluminium Die Casting
23	Strainer	1	Plastic	64	Motor Frame	1	SUS304 (EN-X5CrNi18-10)
25	Mechanical Seal	1	D-12B	68	Handle	1	Plastic
35	Oil Plug	1	SUS304 (EN-X5CrNi18-10)	76	Capacitor	1	
36	Lubricant		White Oil (ISO VG15)	106	Float	1	Plastic
46	Air Release Valve	1	Glass Ball				
50	Motor Bracket	1	Aluminium Die Casting				
51	Head Cover	1	Plastic W/GF				
52A	Upper Bearing	1	6201ZZC3				
52B	Lower Bearing	1	6201ZZC3				
53	Motor Protector	1					

Pump Performance Curve

OMA2

Discharge Bore	32 mm
Total Head	max. 7,5 m
Capacity	max. 0,195 m ³ /min
Motor Output	0,15 kW
Motor Input	0,30 kW
Phase	1
Voltage	110/230 V
Frequency	50 Hz
Rated Current	3,1/1,6 A
Starting Current	8,1/4,3 A
Poles	2
Revolution	S.S. 2850 r.p.m.
Starting Method	capacitor
Insulation Class	E

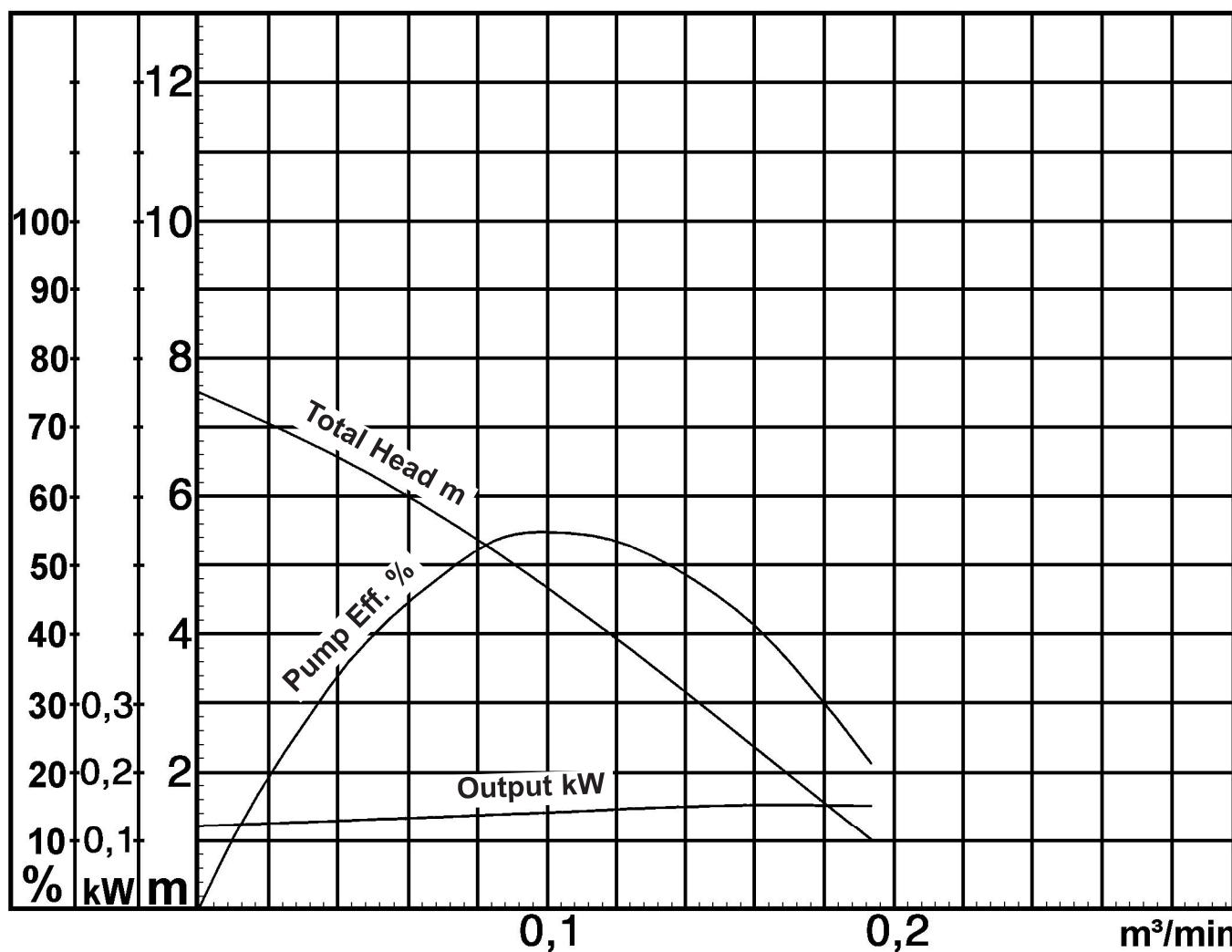

OMA2 (A-1)

Specifications OM(A)

FEATURES

1. Vortex, FRP (Fibreglass Reinforced Plastic) impeller passes solids and stringy material without clogging and increases wear resistance when pumpage contains abrasive particles.
2. Double inside mechanical seals with silicon carbide faces, running in an oil filled chamber and further protected by a lip seal, provides for the most durable seal design available.
3. Highly efficient, continuous duty, air filled, copper wound motor with insulation class E minimizes cost of operation.
4. Built in thermal and amperage sensing protector prevents motor failure due to overloading, or accidental run-dry conditions.

APPLICATIONS

1. Residential effluent, wastewater and site drainage
2. Decorative waterfalls, fountains and fish ponds



SPECIFICATIONS

Discharge Size.....	32mm
Power output	0,15kW
Performance range.....	0,015m ³ /min - 0,19m ³ /min 1,0m - 7,5m
Maximum water temperature...	40°C
Materials of construction	
Impeller.....	Glassfibre reinforced plastic
Casing.....	Glassfibre reinforced plastic
Motor Frame.....	Stainless steel SUS304 (EN-X5CrNi18-10)
Shaft.....	Stainless steel SUS403 (EN-X6Cr13)
Fasteners.....	Stainless steel SUS304 (EN-X5CrNi10-10)
Elastomers.....	NBR (Nitril Buna Rubber)
Mechanical Seal	
Primary Seal.....	Silicon carbide on silicon carbide
Secondary Seal.....	Ceramic on carbon
Impeller Type.....	Vortex
Solids handling capability.....	10mm
Bearings.....	Pre-lubricated, double shielded ball bearings
Motor.....	Air filled, 2850 rpm, 230V, 50Hz, 1-phase Insulation class E
Options.....	Automatic version available (float switch)

motralec

4 rue Lavoisier . ZA Lavoisier . 95223 HERBLAY CEDEX
Tel. : 01.39.97.65.10 / Fax. : 01.39.97.68.48
Demande de prix / e-mail : service-commercial@motralec.com

www.motralec.com