

OPERATING LIMITS

Capacities up to:	420 m ³ /h
Heads up to:	75 m
Max. working pressure:	16 bar
Temperature range:	- 10° to + 110° or 130°C
ND of ports:	40 to 200

LRC-JRC

SINGLE AND TWIN IN-LINE PUMPS

Heating, Air conditioning, Secondary hot water

50 Hz

motralec

4 rue Lavoisier . ZA Lavoisier . 95223 HERBLAY CEDEX
Tel. : 01.39.97.65.10 / Fax. : 01.39.97.68.48
Demande de prix / e-mail : service-commercial@motralec.com
www.motralec.com

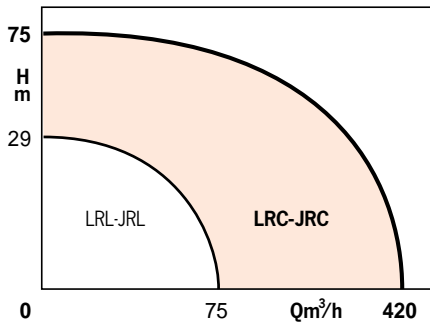

APPLICATIONS

- Low pressure heating systems.
- Chilled water systems.
- Cooling water systems.
- Secondary hot water distribution loop.

And for all industries requiring the pumping of clear liquids, chemically neutral and free of abrasive particles in suspension.

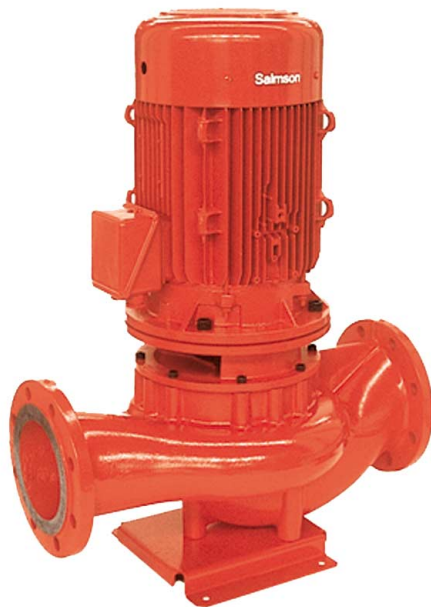

• LRC single pump

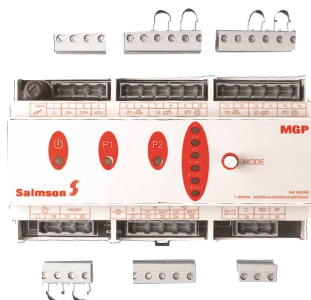

• MGP control and protection box for JRC.
To be integrated in an existing panel



• JRC twin pump (with standby pump)

LRC-JRC

ADVANTAGES

- Thermal overload protection on all motors.
- Direct mounting on horizontal or vertical pipe or block.
- No coupling: no need for shaft alignment.
- Permanent de-aerating device on mechanical seal.
- Quick and easy installation.
- Practically no maintenance required.

JRC

- Availability of a standby pump at all times.
- Possibility of operating the two pumps in parallel.
- Changeover between pumps may be manual or automatic by MGP control box.

DESIGN

Pump

Centrifugal, single-stage.
Flanged casing, **IN-LINE** ports.
Flanges with pressure ports.
Lantern-bearing joining pump and motor.
Dynamically balanced impeller fitted directly on motor shaft.
Mechanical seal.

JRC

Twin pumps in a single casing.
Hydraulic separation by silent flap.

Motors

With lengthened shaft end.
Shaft-rotor guide bearings chosen for silent operation.
Thermal overload protection by built-in probe, with automatic reset.

Speed : 1450 and 2900 rpm
Winding 3-ph. ≤ 4 kW : 230-400 V
over 4 kW : 400 V Δ
Frequency : 50 Hz
(optional 60 Hz)
Insulation class : F
Protection : IP 54
EC conformity : PR EN 809

CAUTION

The thermal overload protection probe must be connected for the manufacturer's warranty to be valid. See electrical data.

LRC : SECTIONAL DRAWING

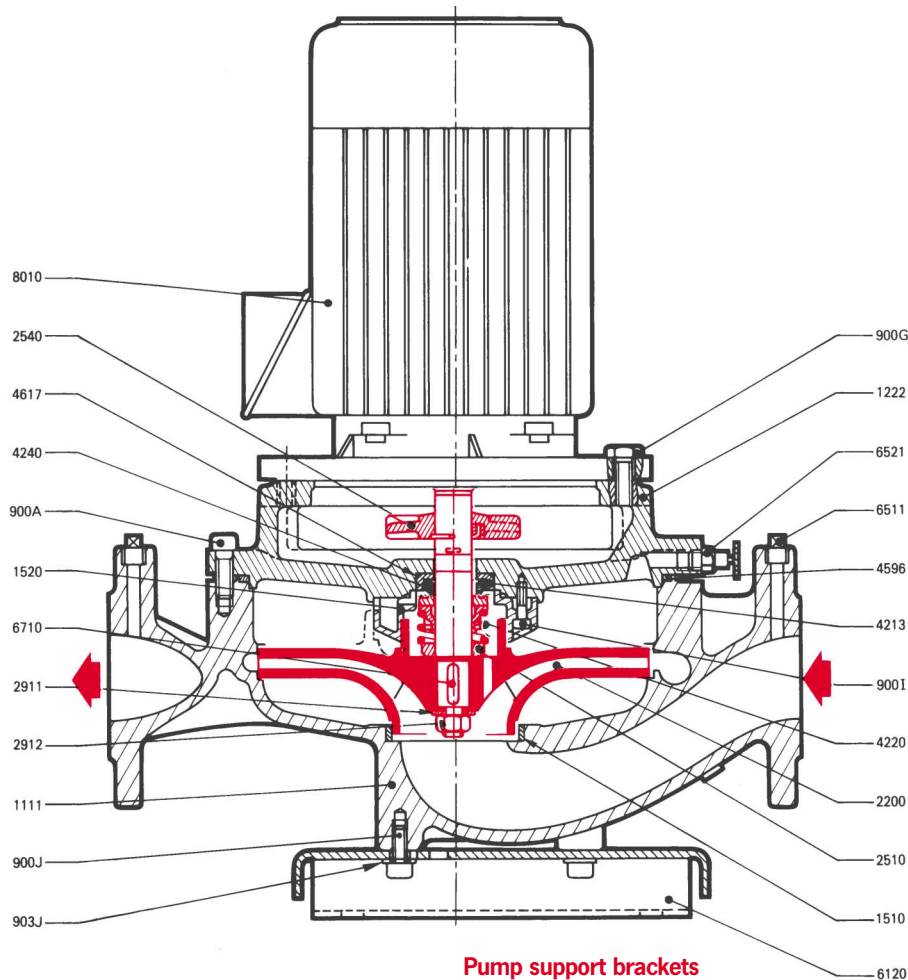

STANDARD CONSTRUCTION

Main parts	Material
Casing	Cast iron (FGL 200)
Spacer	Cast iron (FGL 250)
Impeller {	ND 160 + 110 °C Polypropylene with fiberglass*
	ND 250 + 130 °C Cast iron (FGL 200)
	ND 360 + 130 °C Cast iron (FGL 200)
Shaft	Stainless steel (Z6CND 17/11)
Flap.....	Stainless steel (Z6CND 18/09)
Casing gasket.....	Ethylene-Propylene
Mechanical seal	Graphite/Silicon carbide/EP

* LRC-JRC 410-12 to 16 and 210-12 to 16 impeller made of FGL 200.
** ND 160: + 130°C on request.

PUMP IDENTIFICATION

LRC 404-24/1,5
JRC 420-25/15

LRC: single pump code
JRC: twin pump code
2 = 2 pole, 2900 rpm
4 = 4 pole, 1450 rpm

Port Ø in cm

Impeller Ø in cm

Motor power in kW

JRC: SECTIONAL DRAWING

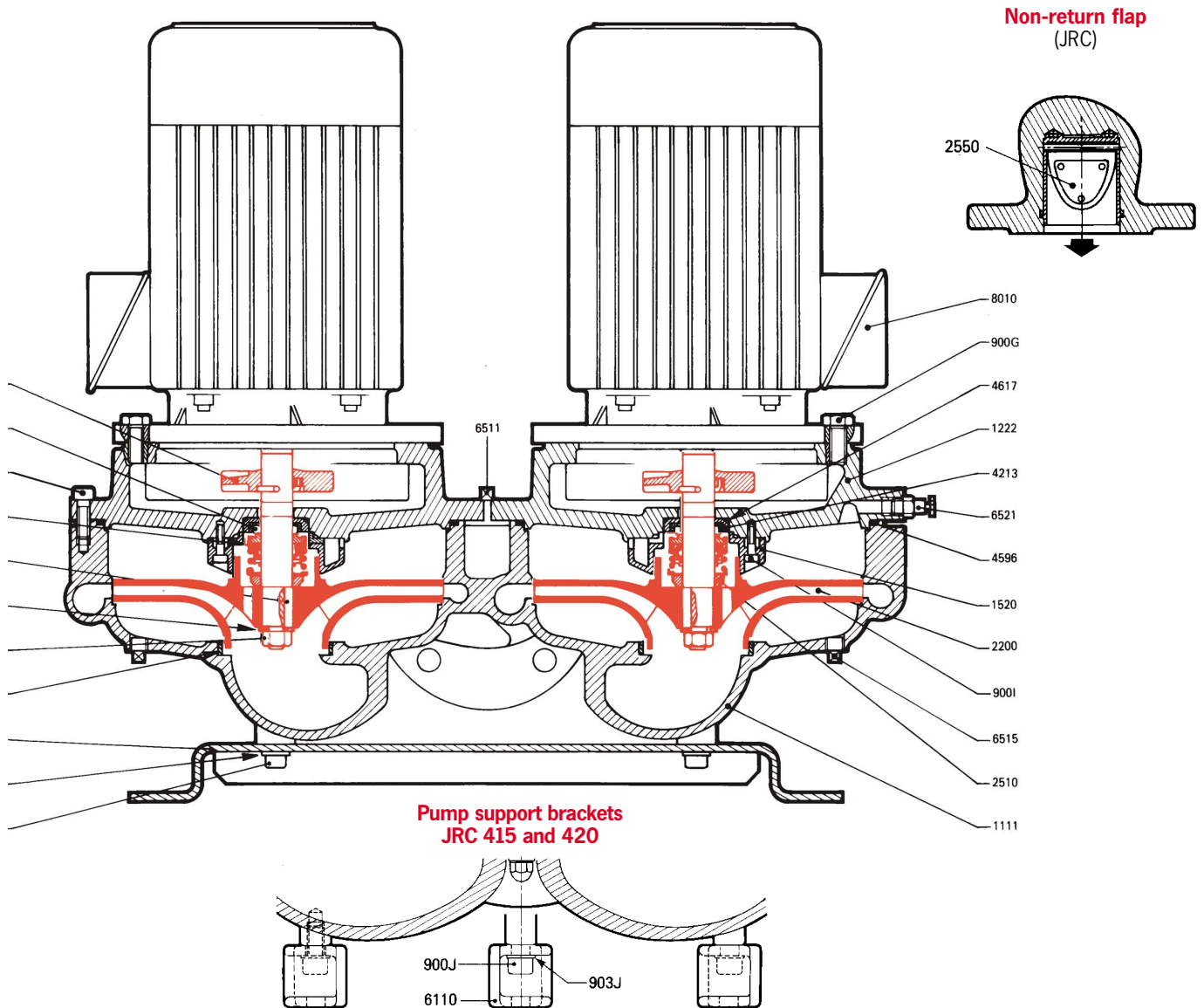

LRC-JRC PARTS LIST

- | | |
|---|---------------------------------------|
| 900A – Screw (pump casing-spacer) | 2912 – Nut (impeller) |
| 900G – Screw (spacer-motor) | 4213 – Bush holder |
| 900I – Screw (impeller rear wear plate) | • 4220 – Stationary seat } mechanical |
| 900J – Screw (base plate or brackets) | • 4240 – Rotary face } seal |
| 903J – Washer (under screw 900J) | • 4596 – Casing O-ring |
| 1111 – Pump casing | • 4617 – Bush holder O-ring |
| 1222 – Spacer | 6110 – Pump support brackets |
| • 1510 – Impeller front wear ring | 6120 – Pump base plate |
| • 1520 – Impeller rear wear plate | 6511 – Gauge tapping plugs |
| • 2200 – Impeller | 6515 – Casing drain plugs |
| 2510 – Mechanical seal stop ring | 6521 – Air vent cock |
| • 2540 – Deflector with circlip | • 6710 – Impeller key |
| • 2550 – Non-return flap | • 8010 – Electric motors |
| 2911 – Washer (under impeller nut) | (*) Recommended spare parts |

MECHANICAL SEAL

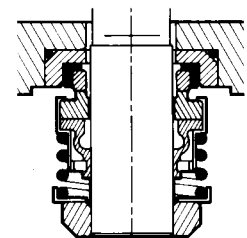

Operating limits with glycolated water:
 – Max. concentration 40% for max. temperature + 70°C. Above, contact us.

LRC-JRC

LRC: PRE-SELECTION GRAPHS

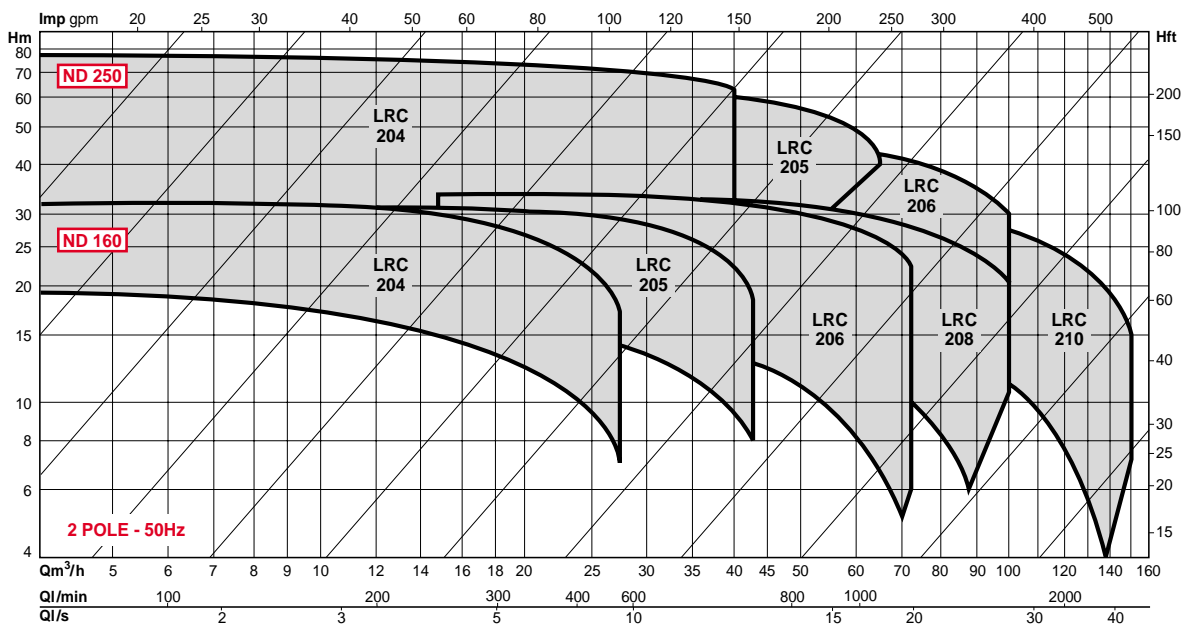
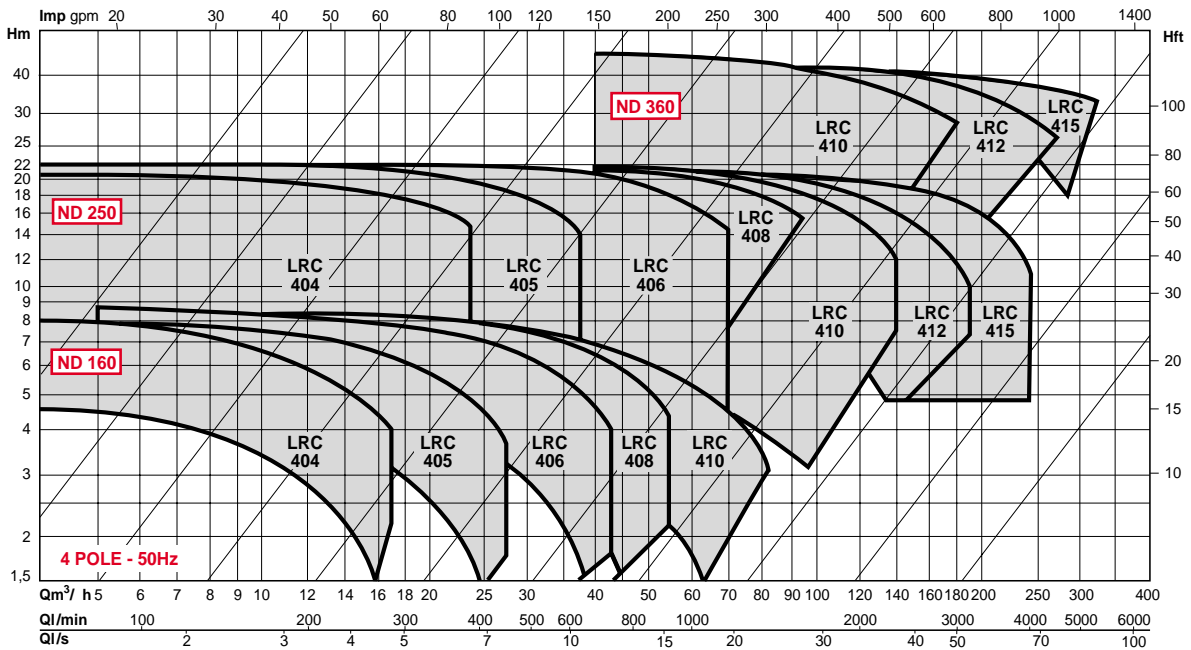

PERMISSIBLE MOUNTING

on vertical or horizontal pipe, or on solid base.

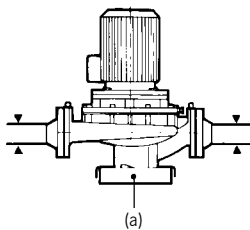

(a) pump base that can be separated from the casing if necessary.

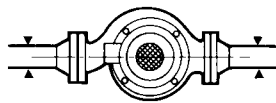

direct mounting on pipe possible up to 3 kW.

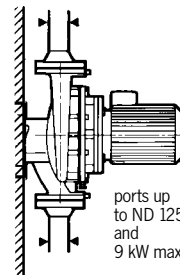

ports up to ND 125 and 9 kW max.

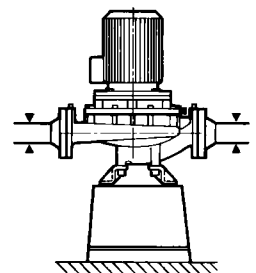

JRC: PRE-SELECTION GRAPHS

Hydraulic performances with one pump in operation

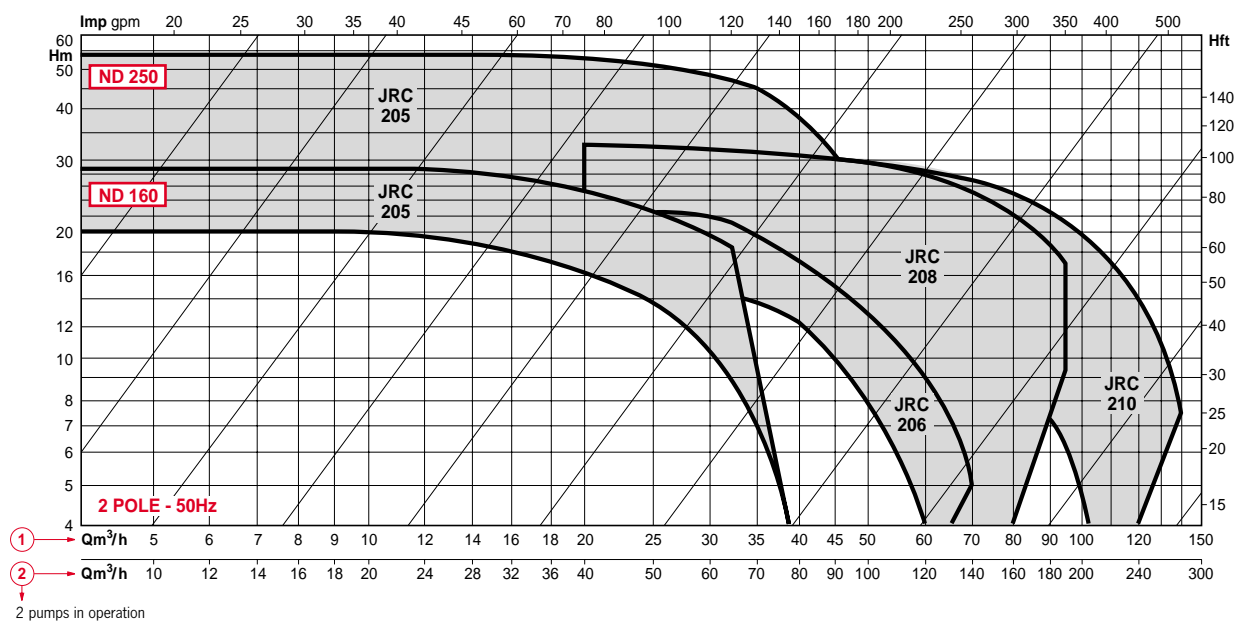
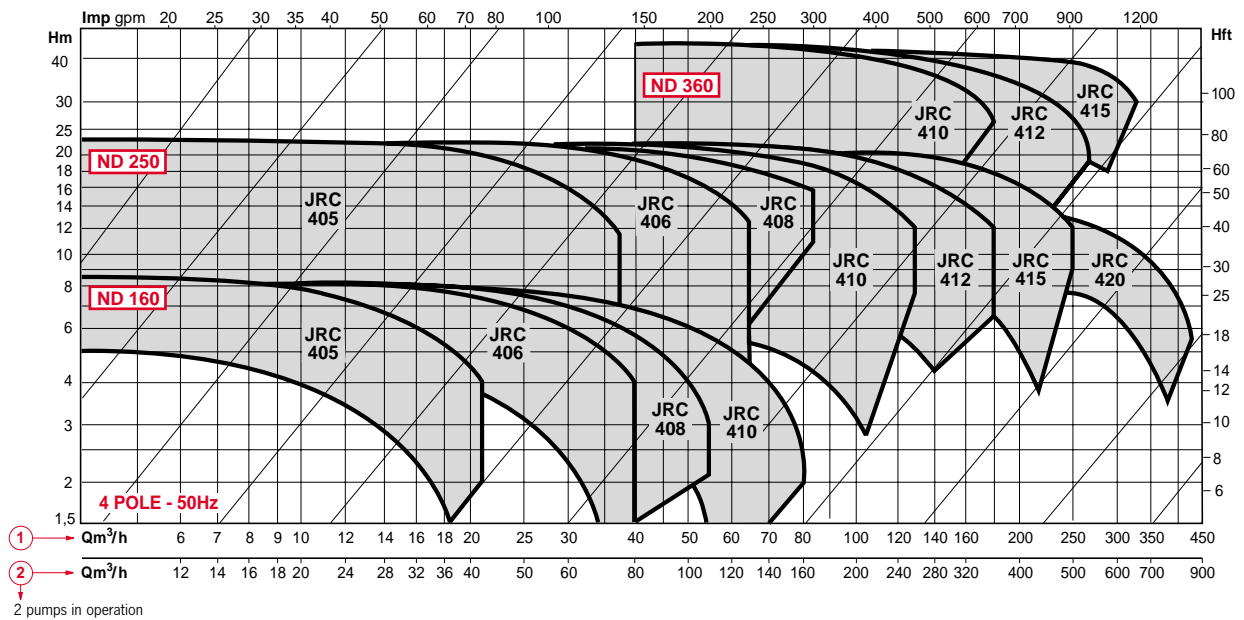

PERMISSIBLE* MOUNTING

on vertical or horizontal pipe, or on solid block.

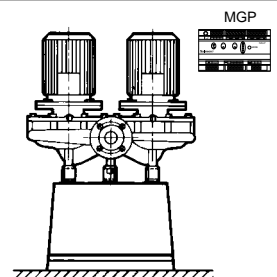
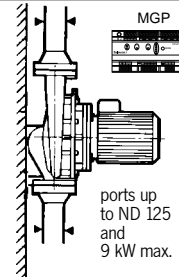
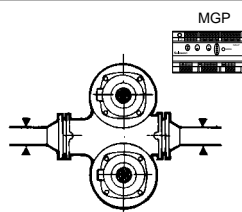
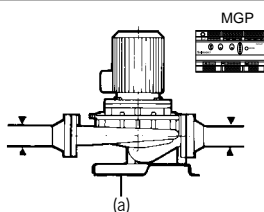

*To prevent the flap from malfunctioning, do not mount a butterfly valve directly on flange.

LRC-JRC

LRC 4 POLE

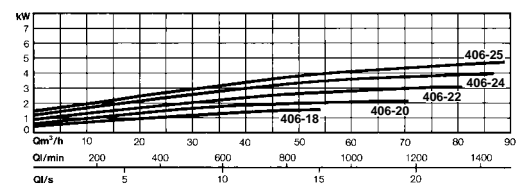
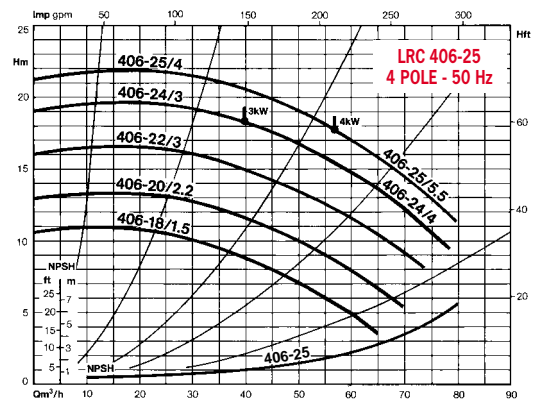
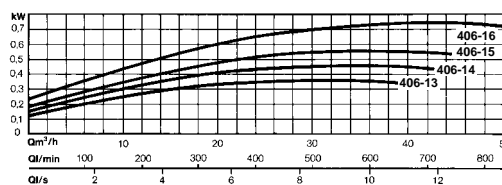
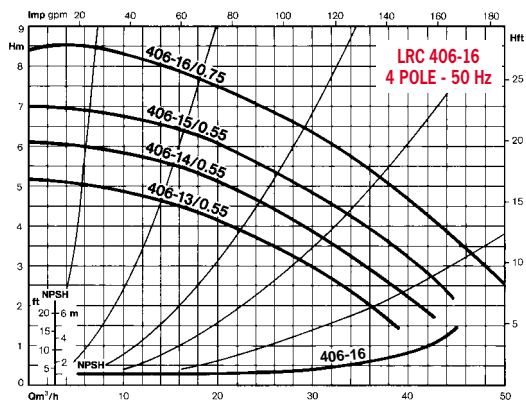
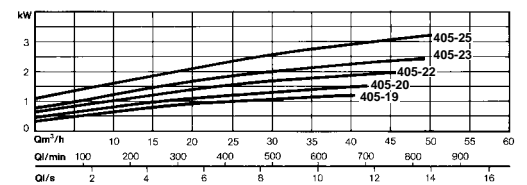
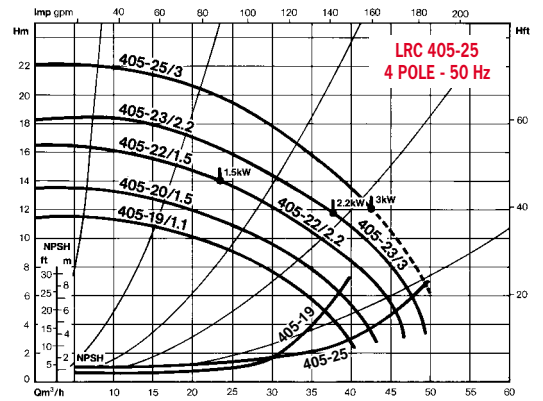
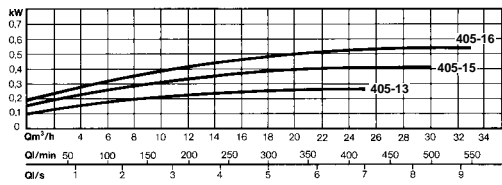
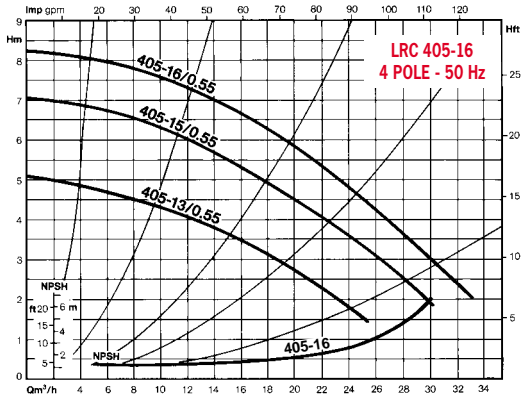
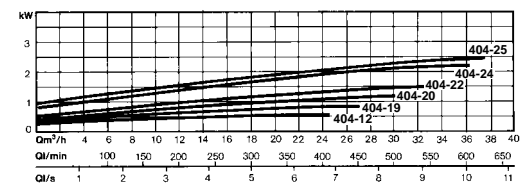
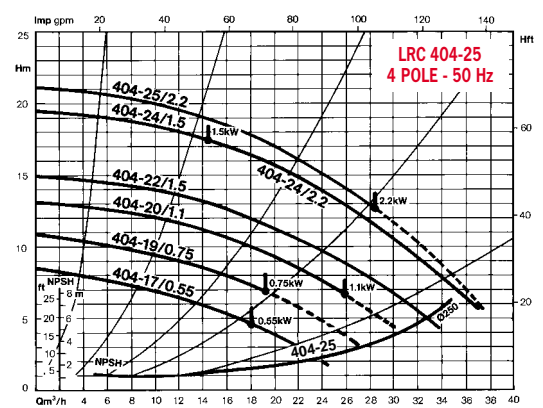
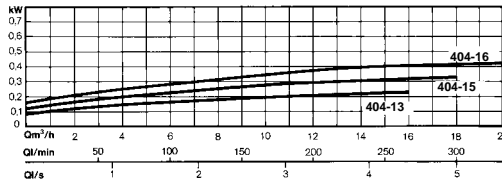
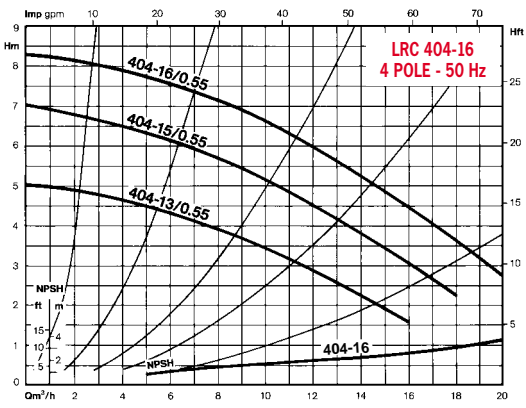

LRC 4 POLE

LRC-JRC

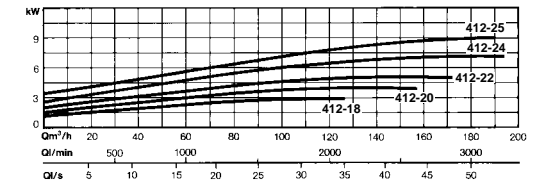
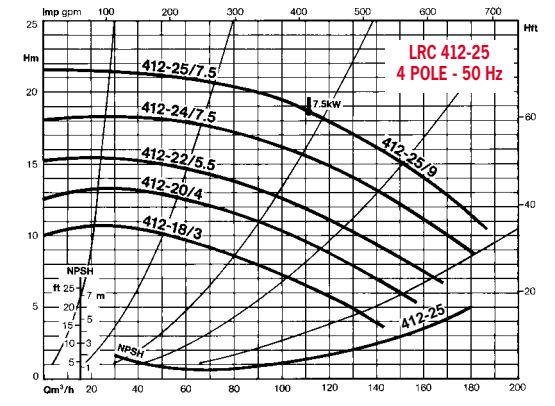
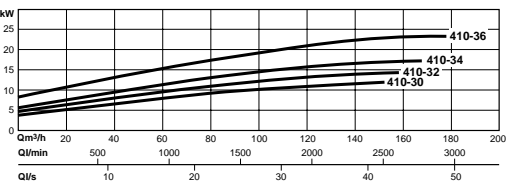
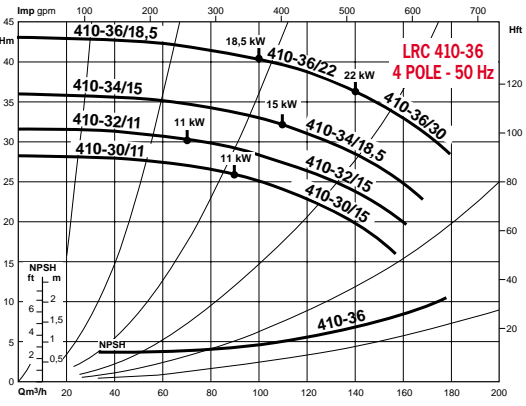
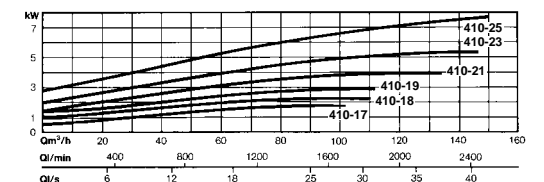
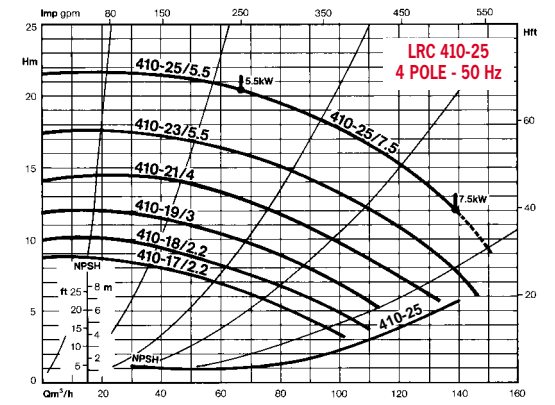
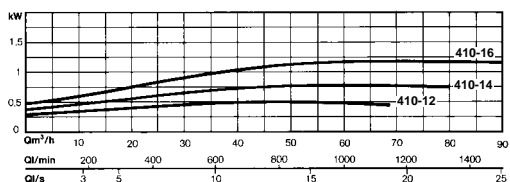
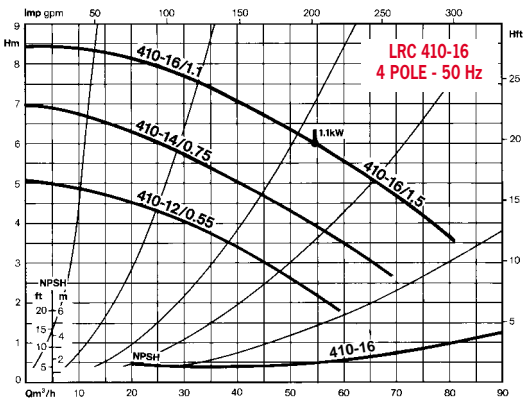
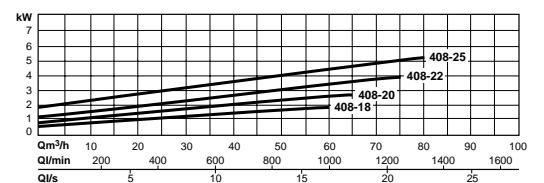
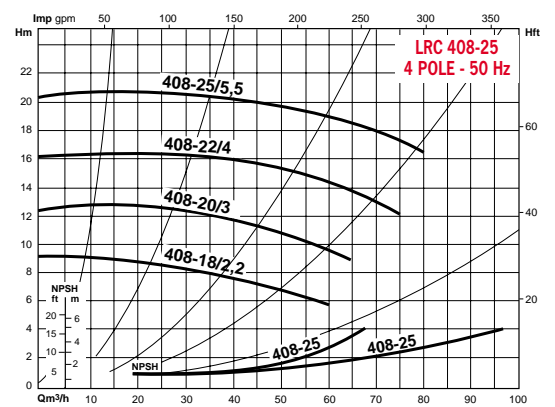
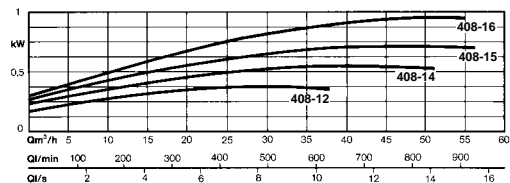
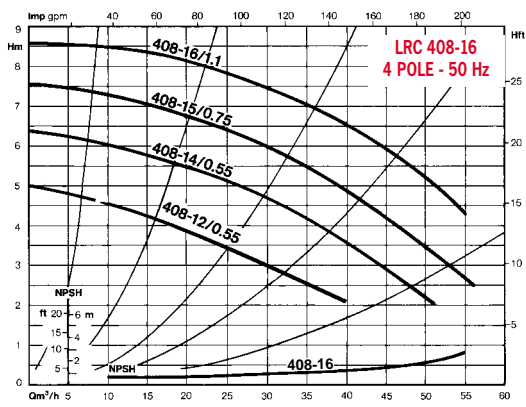

LRC-JRC

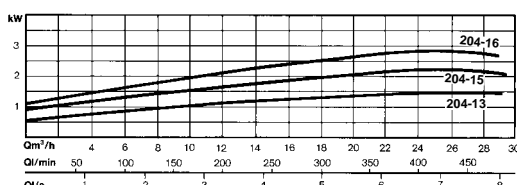
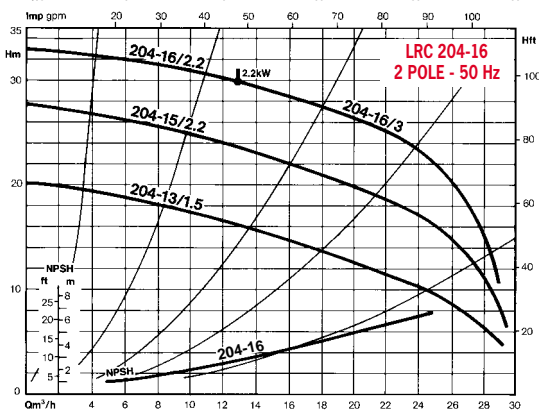
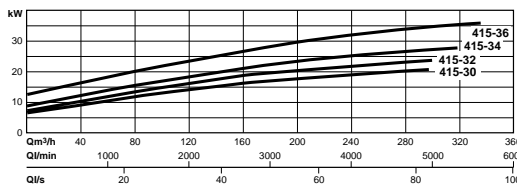
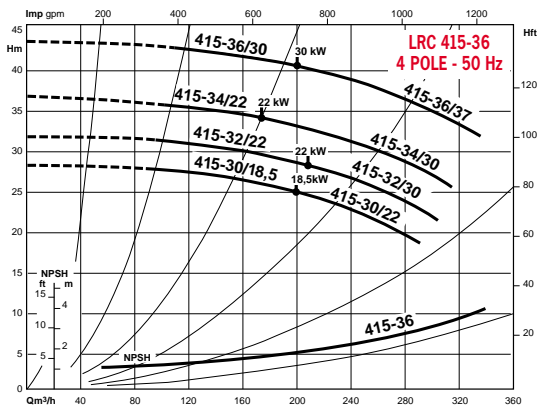
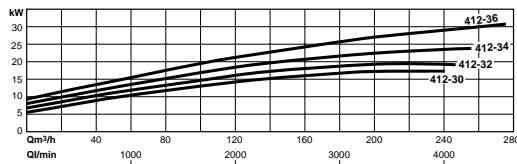
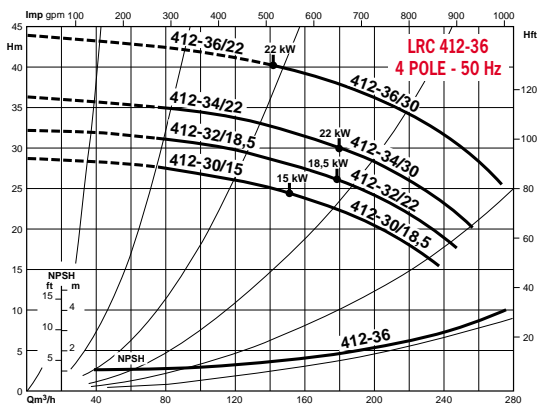

LRC 4 POLE

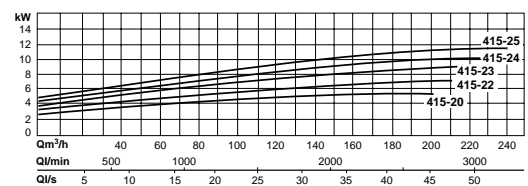
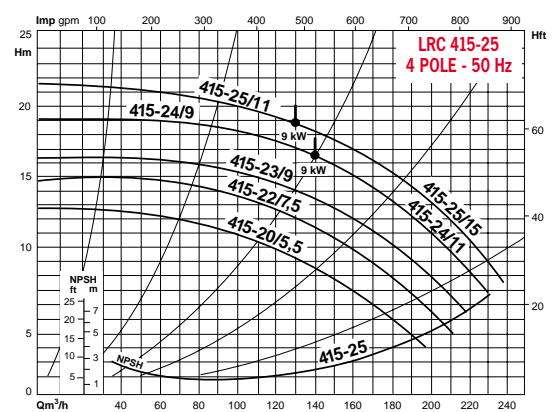

LRC 2 POLE

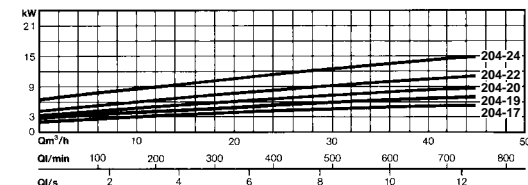
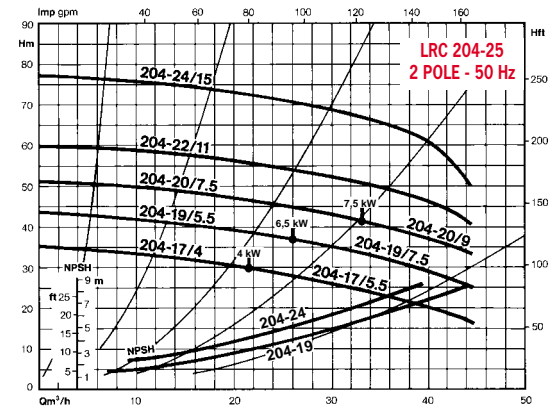

IF THE INSTALLATION
REQUIRES SPECIAL
ARRANGEMENTS FOR
ACOUSTIC INSULATION,
SELECT PUMPS AT
1450 RPM.

LRC 2 POLE

LRC-JRC

IF THE INSTALLATION
REQUIRES SPECIAL
ARRANGEMENTS FOR
ACOUSTIC INSULATION,
SELECT PUMPS
AT 1450 RPM.

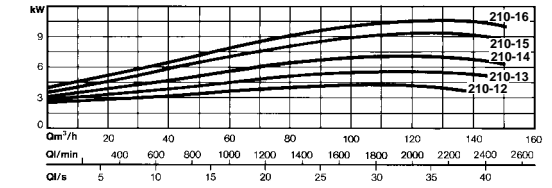
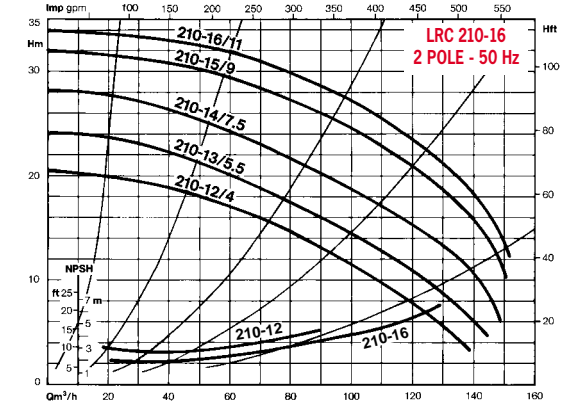
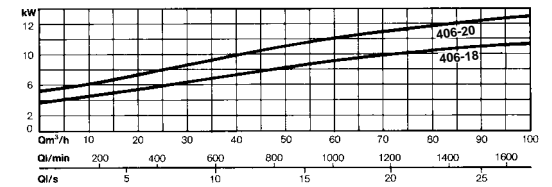
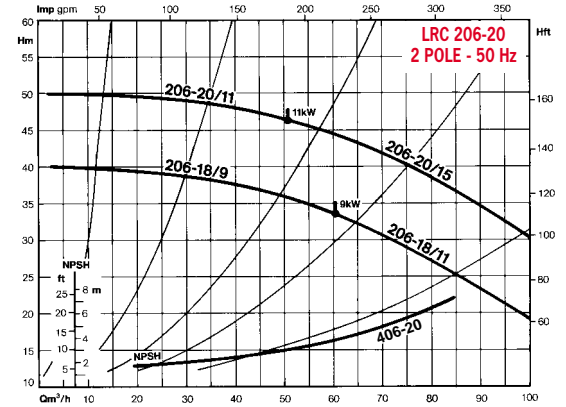
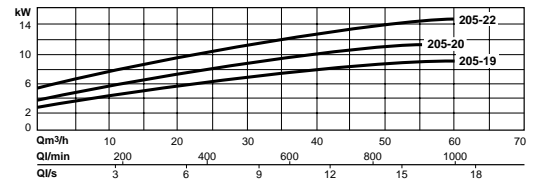
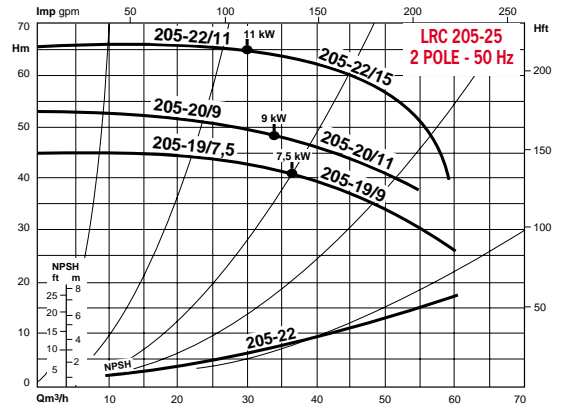
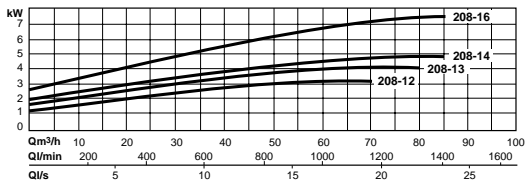
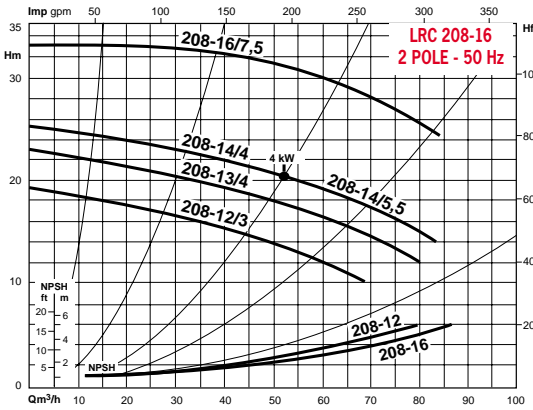
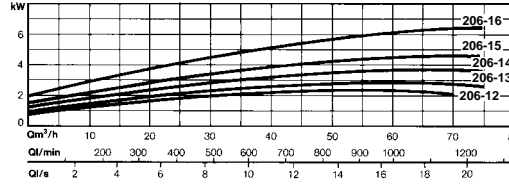
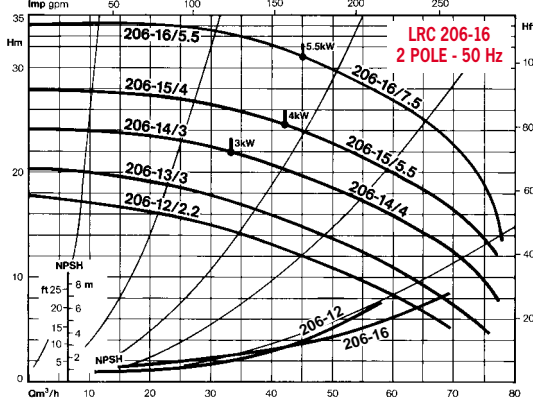
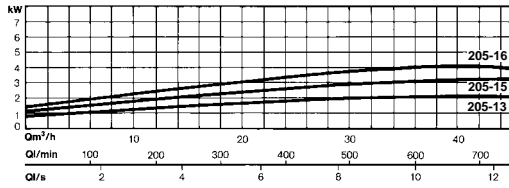
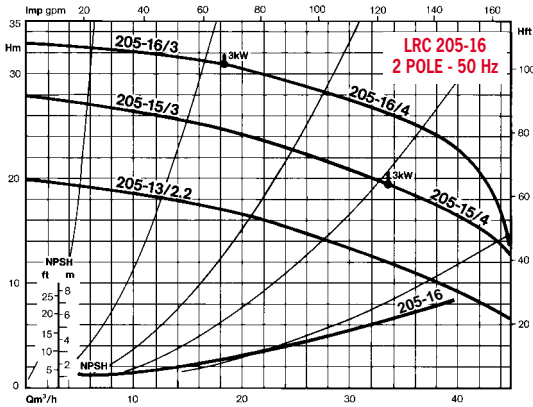

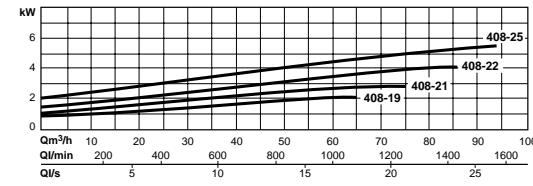
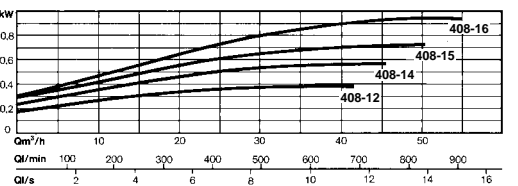
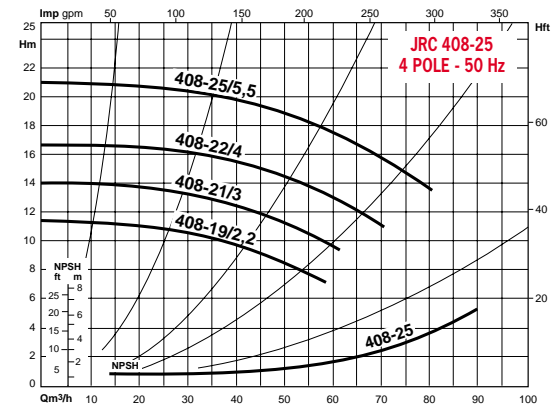
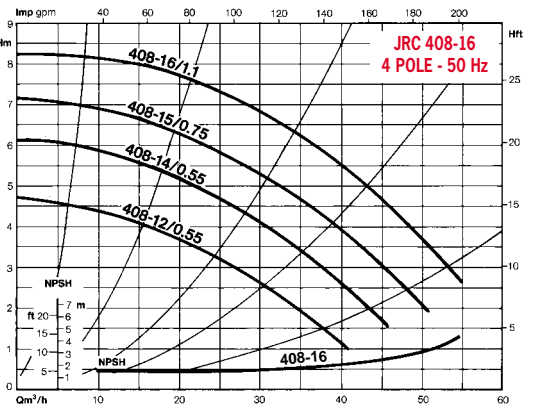
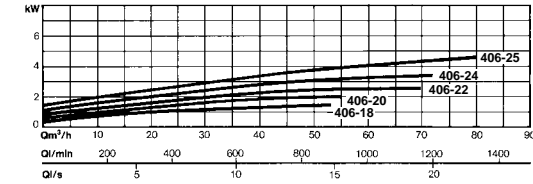
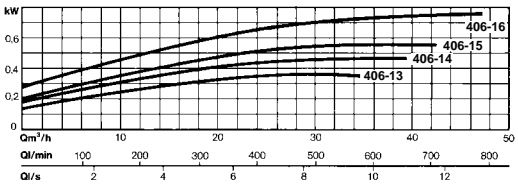
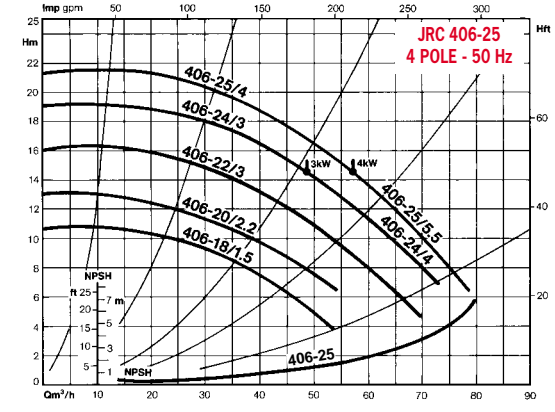
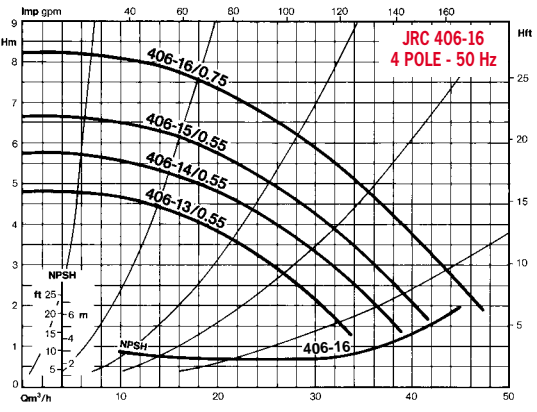
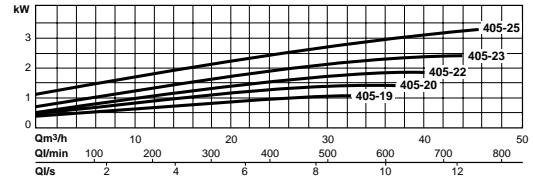
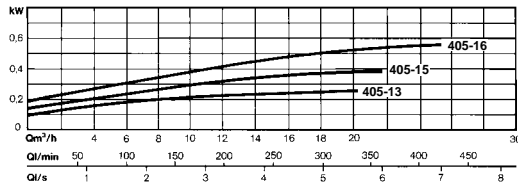
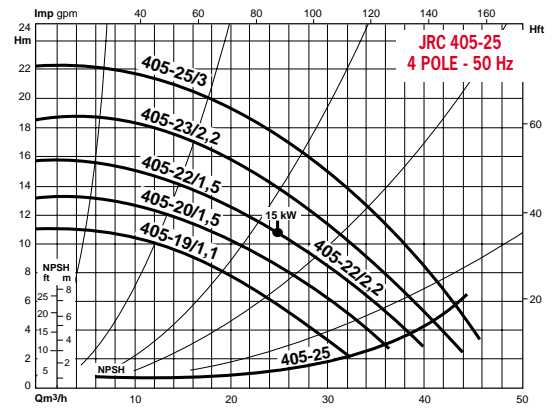
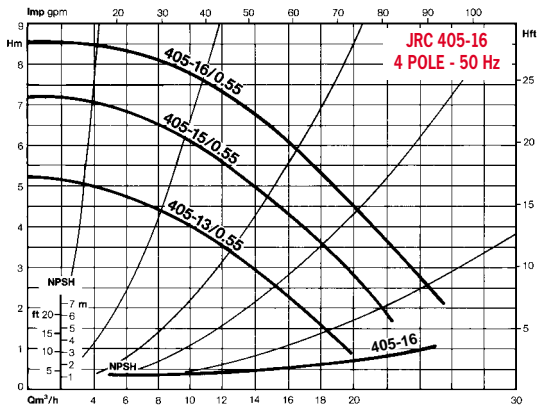

JRC 4 POLE

LRC-JRC

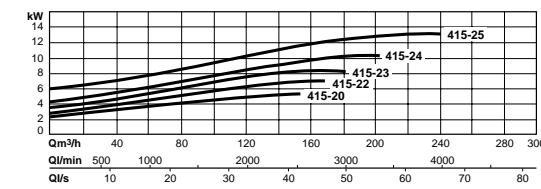
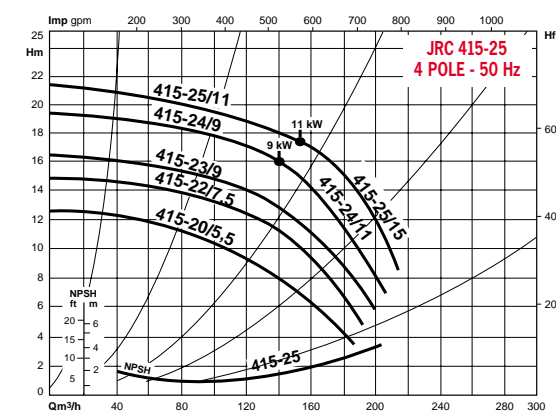
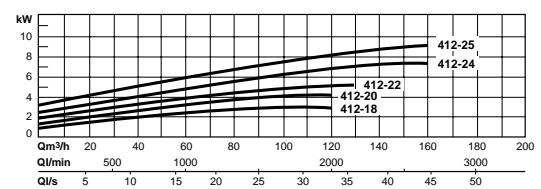
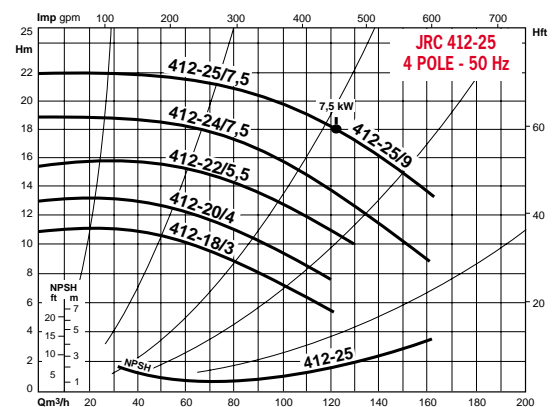
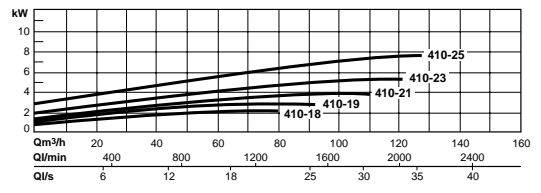
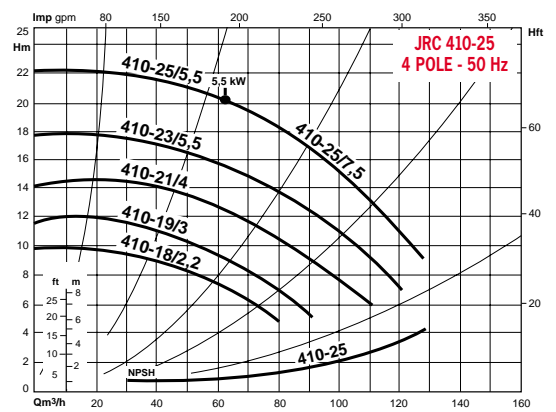
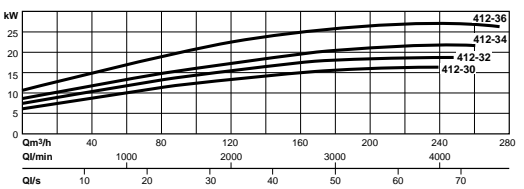
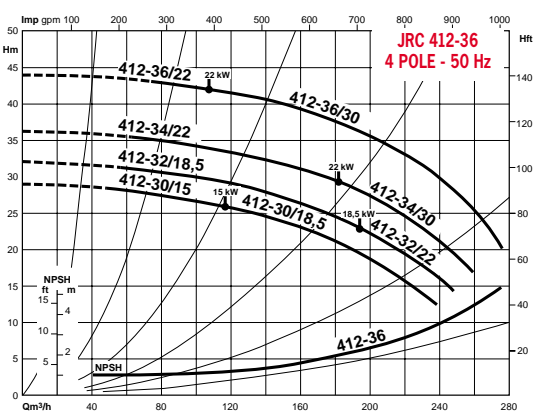
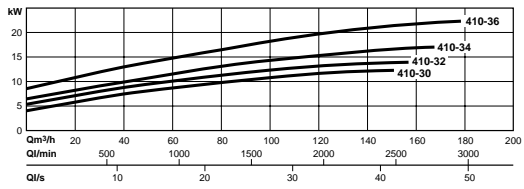
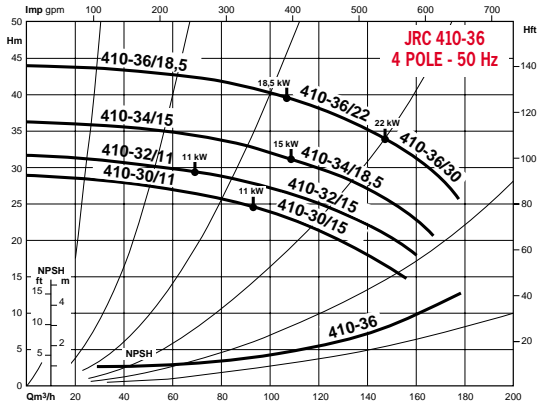
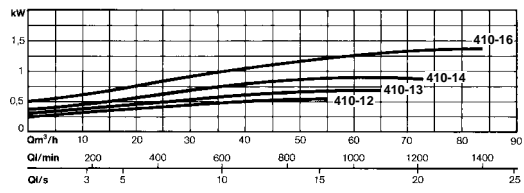
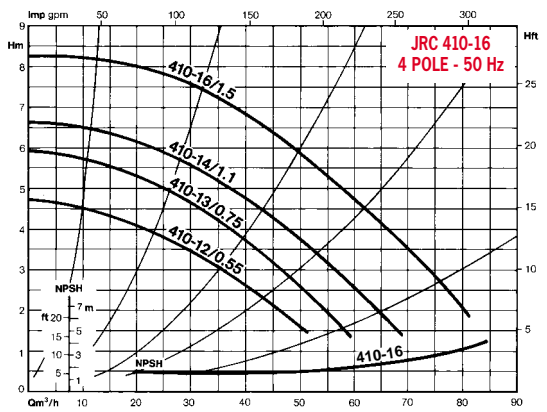

LRC-JRC

JRC 4 POLE

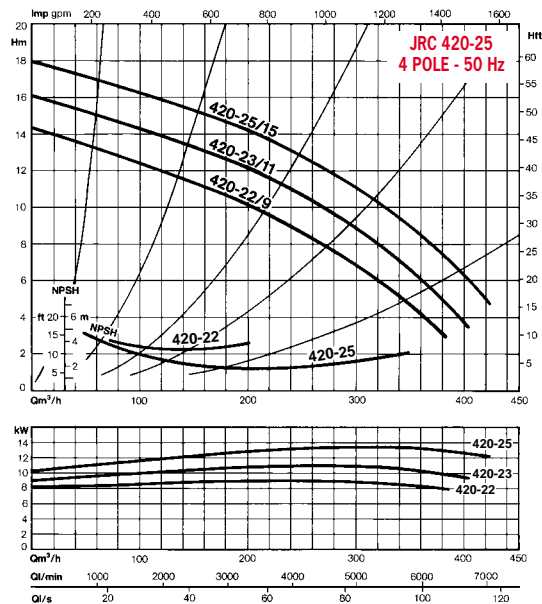
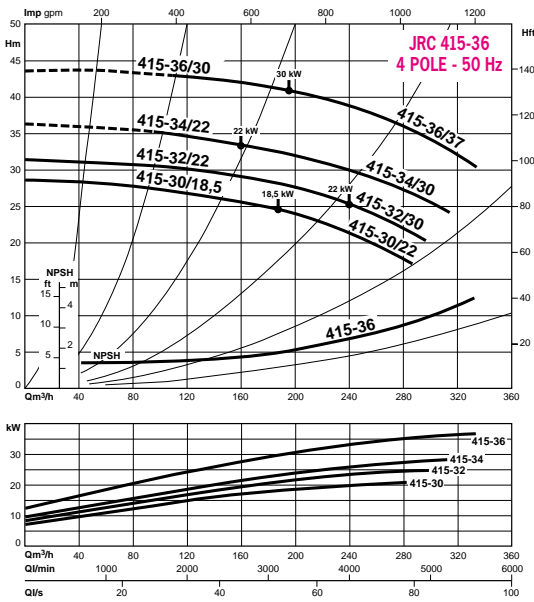

DISMANTLING A MOTOR-HEAD

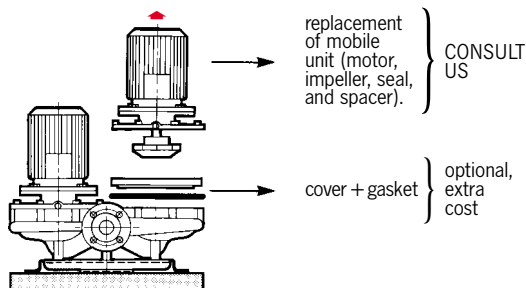

BLANK COVER WITH GASKET

type of pump with impellers	ORDER REFERENCE	ITEM REFERENCE
ND 120 to 160	COUV. 16	30 922 652 X
ND 170 to 250	COUV. 25	30 922 653 F
Above and up to ND 360	COUV. 36	4 004 999

STANDBY OPERATION P1 OR P2

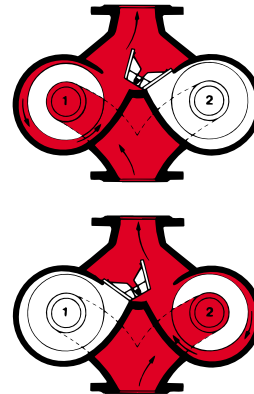

ONE PUMP ON STANDBY FOR OPERATING RELIABILITY WITHOUT STOPPING THE INSTALLATION

Changeover and programming of pump operation by MGP control box

OPERATION IN PARALLEL P1 + P2

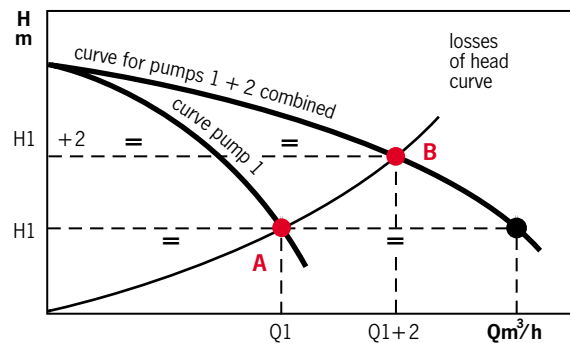
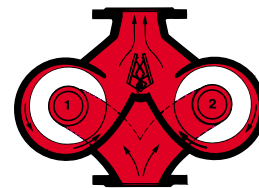

Twin pumps are installed for dependability, to make sure that the installation will not be shut down if one pump fails.

However, the MGP box also allows parallel operation of the two pumps.

Running both pumps increases the flowrate for a given loss of head in the mains.

The resulting pump characteristic curve (1 + 2) is found by doubling the flowrate at each head.

The losses of head in the mains are proportional to the square of the flowrate.

- Point A: one pump in operation.
- Point B: two pumps in operation.

JRC 2 POLE

LRC-JRC

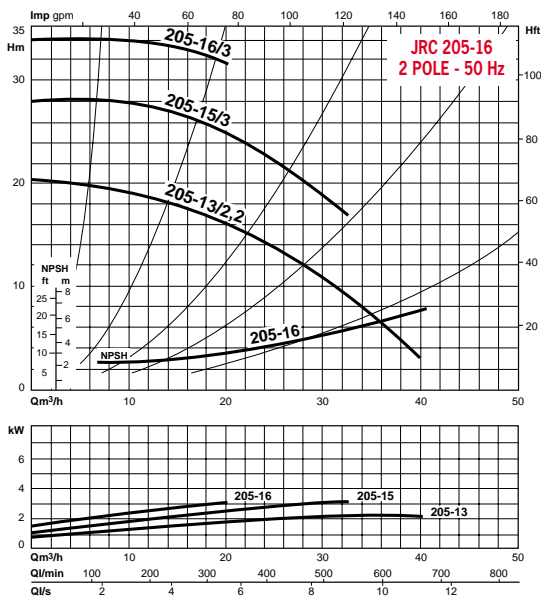

IF THE INSTALLATION REQUIRES SPECIAL ARRANGEMENTS FOR ACOUSTIC INSULATION, SELECT PUMPS AT 1450 RPM.

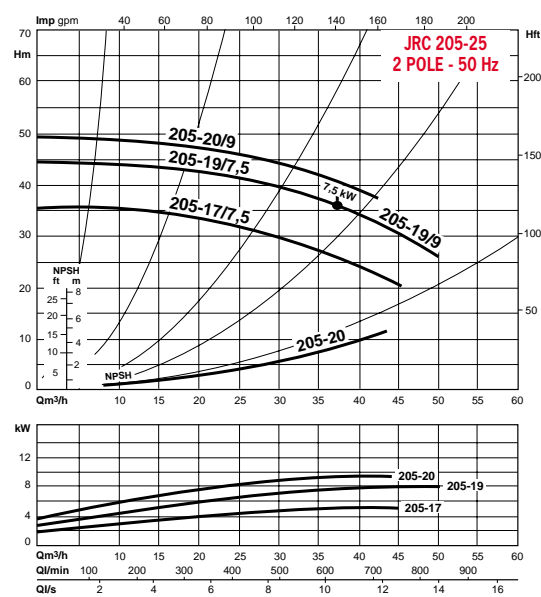

CONTROL BOX MGP

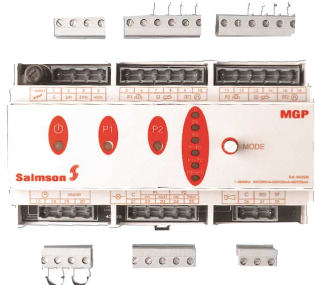

Control and thermal overload protection of motors. Operating reliability through automatic starting of the standby pump if the pump in service fails.

For further technical information, see data sheet for MGP control boxes.

