

ProCam^{MD}

Metering Pump Operation and Maintenance Manual



**Read and understand this manual
prior to installing, operating or servicing this equipment.**



motralec

4 rue Lavoisier . ZA Lavoisier . 95223 HERBLAY CEDEX
Tel. : 01.39.97.65.10 / Fax. : 01.39.97.68.48
Demande de prix / e-mail : service-commercial@motralec.com
www.motralec.com

Table of Contents

Service Information	5
Customized Solutions	5
Bran+Luebbe Diagnostics Systems	5
Spare Parts Order	6
1 Safety	7
1.1 Safety Instructions	7
2 Product Attributes.....	13
2.1 ProCam ^{MD}	13
3 Assembly Groups.....	15
3.1 Gear Unit.....	15
3.1.1 Gear Models G1 and G2 for Procam ^{MD}	15
3.2 Stroke Length Adjustment	17
3.2.1 Manual Stroke Length Adjustment at Standstill and in Operation for Gear Models G1 and G2.....	17
3.3 Pump Head.....	19
3.4 Valves 25	
3.5 Bleed Valve for Product Chamber	26
3.5.1 Diaphragm Pumphead	26
4 Installation	28
4.1 Installation.....	28
4.2 Suction and Discharge Lines	30
4.3 Installation - Examples.....	32
4.3.1 Suction and Discharge Piping	32
5 Operation	35
5.1 Lubricant and Lubricant Change.....	35
5.2 Oil Quality and Quantity for Gear Unit G1 and G2	37
5.3 Start-up Procedure.....	38
5.4 Adjustment of the Capacity.....	40
5.4.1 Flow Rate Curve.....	43
6 Maintenance, Inspection, Cleaning.....	44
7 Trouble Shooting.....	47

8	Transport, Intermediate Storage, Preservation.....	49
	ProCam ^{MD}	49
	8.1.1 Transport	49
	8.1.2 Intermediate Storage.....	50
	8.1.3 Preservation	50
9	Data, Drawings and Parts Lists.....	51
	9.1 Pump Data – Maximum Capacity	51
	9.2 Material of Construction.....	51
	9.3 Drawings and Parts List.....	52
10	Drive Lubrication and Frequency	67

Service Information

Customized Solutions



- Genuine spares and consumables
- Replacement parts in 24 hours
- Local service, maintenance and start-up support
- Maintenance contracts
- In-house repairs
- Training
- On-line / Off-line Diagnostic

Bran+Luebbe Diagnostics Systems

pV-Diagram

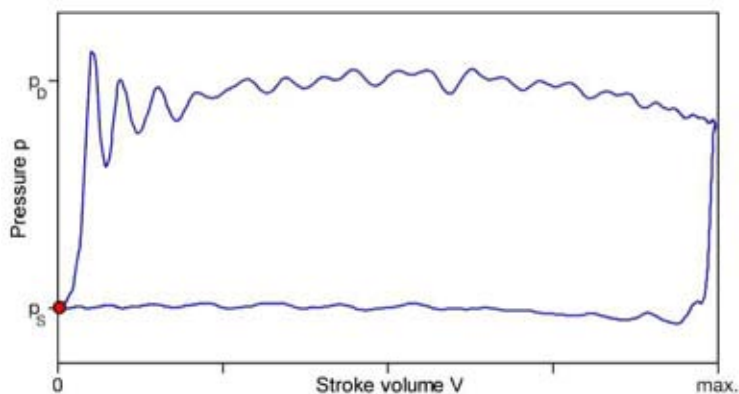

For monitoring of our high grade diaphragm and process pumps Bran+Luebbe offers two qualified diagnostic systems:

- **NOVALINK-DSM Off-line**
and
- **NOVALINK-CSM On-line**

Please contact your local B+L customer support location for convenient service

NOVALINK - DSM Off-line Diagnostics System

NOVALINK-DSM is an off-line diagnostics system which is temporarily connected to a pump for evaluating its condition analogous to an ECG.

NOVALINK - CSM Continuous Status Monitoring

NOVALINK-CSM is an on-line diagnostics system which continuously monitors the performance of a metering pump

Spare Parts Order

Only the use of original BRAN+LUEBBE spare parts will ensure proper operation, reliability and long service life.

To ensure accurate and prompt parts delivery the following information must be provided when ordering parts:

- Serial number *(see nameplate of the pump)*
- Model number *(see nameplate of the pump)*

Recommended spares are listed in bold type on the pumphead part lists in section 9.

For spares and technical support, contact:

SPX Process Equipment
600 Sugar Creek Road
Delavan, WI 53115
Tel: 1.800.252.5200 or (262)728.1900
Fax: 1.800.252.5012 or (262)728.4904
E-Mail: spxpe@spx.com
Web site: www.spxpe.com

1 Safety

1.1 Safety Instructions

Introduction

The metering pump is equipped with protective devices. This pump has been subjected to a safety test and acceptance inspection.

In case of incorrect operation or misuse, risks are imminent for

- Life and limb of the operator
- The pump and other material assets of the owner-operator
- The efficient operation of the pump

All persons involved in setting up, putting into service, operating, inspecting, servicing and repairing the pump must

- Be properly qualified, and
- Strictly observe these operating instructions.

Your safety is at stake!

Symbols used

The following symbols are used in these operating instructions:

	DANGER! Designates an imminent danger. In case of non-observance of this information, death or severe injuries are an imminent risk.
---	--

	WARNING! Designates a possibly dangerous situation. In case of non-observance of this information, death or severe injuries can occur.
---	--

	CAUTION! Designates a possibly dangerous situation. In case of non-observance of this information, severe injuries can occur.
---	---

	ATTENTION! Designates a possibly dangerous situation. In case of non-observance of this information, minor injuries can occur.
---	--

	Designates important user tips and other useful information..
---	---

Proper Use

This metering pump is an reciprocating, positive-displacement pump. It serves the purpose of conveying, dosing, compressing or mixing and/or filling up liquids and suspensions.

Do not use this pump as

- a generator, i.e. pressurized liquid is not allowed to drive the motor
- a device for cooling liquids
- a pulsator without a pressure valve
- a compressor for gases

The pump and these operating instructions are intended for commercial use exclusively.



WARNING!

Severe skin injuries can result from dangerous (e.g. aggressive, toxic, caustic) media!

Unsuitable media can damage the pump and then escape into the surrounding area.

If you intend to use dangerous media, the materials used for the pump parts must have been designed for this kind of use.

Consult with SPX PROCESS EQUIPMENT!

Arbitrary modifications of the pump are prohibited for safety reasons!

Any form liability on the part of the manufacturer/supplier shall be excluded for any form of damage caused by arbitrary modifications.

If you intend to carry out any modifications on the pump, please note that each modification must be approved in writing by SPX PROCESS EQUIPMENT.

When replacing defective parts, only use original spare parts or standard parts approved by the manufacturer.

Emissions

The construction or design does not exclusively determine the sound emission of metering and process pumps. It also depends on the many different operations-related parameters, such as the type and size of the pulsation dampers being used, customer-specific piping, type of setup, ambient temperatures, and the physical properties of the medium being conveyed.

The highest “sound pressure level” the metering pump will produce is through the drive (motor or variable speed drive). For noise levels of drives see the manufacturers catalogue (see section 10).

The determination of the exact A-rated, equivalent continuous sound level as a series-related limit value is therefore possible only to a limited extent.

Table 1.1 provides **reference values**, measured:

- At full capacity utilization of the machines,
- Under normal operating conditions,
- At room temperature,
- With water as the medium being conveyed.

The sound measurement was carried out in accordance with DIN 45635 Part 1.

The actual max. sound pressure level must be determined on site by the owner-operator.

The owner is responsible for proper observance of the local, legal safety regulations for noise.

Please note the following information whenever the determined sound pressure level exceeds 85 dB(A):

Gear unit type	L (A) dB	P Drive HP
G1 (MD15, MD50)	70	0,25
G2 (MD200)	78	1.0
L (A) = max. sound pressure level at 1-meter distance		
P drive = max. rated drive power at 188 strokes/min.		

Table 1.1: Continuous sound pressure level ProCam individual machines

	<p>CAUTION!</p> <p>Auditory damage due to noise.</p> <p>Noise can result in loss of hearing or in other physiological impairments (e.g. loss of equilibrium, inattentiveness).</p> <p>Wear ear protection!</p>
---	--

Sources of Danger

BRAN+LUEBBE metering pumps comply with all mandatory legal safety requirements. The dangers originating from the pump have been virtually reduced to a minimum by means of suitable construction and design measures. However, residual risks (explosive atmospheres and electrical, mechanical, thermal or biological hazards) cannot be excluded entirely during either transport, installation, maintenance and repair work or regular operation.



IMPORTANT!

Please note the warning and safety information included in the following sections in order to prevent personal and property damage:

- 2 “Product Attributes”**
- 3 “Assembly Groups”**
- 4 “Installation”**
- 5 “Operation”**
- 6 “Maintenance, Inspection, Cleaning”**
- 8 “Transport, Intermediate Storage, Preservation”**

Workplaces

The workplaces of the operating personnel during the production operations can vary.

In the case of operating, maintenance and repair tasks, the area next to the pump and the pump itself must be considered as being a workplace.

Authorized Operators

Only persons who have been properly authorized and trained by the owner-operator are allowed to work on the pump. The minimum age for operators is 16 years. The operator, versus others in the work area, is considered to be responsible for work on the pump.

The responsibilities for the various activities performed on the pump must be clearly defined and observed. Unclear competencies are a safety risk.

The owner-operator must

- make these operating instructions accessible to the operator and
- make sure that the operator has read and understood them.







IMPORTANT!

Maintenance, upkeep and electrical tasks should only be performed by technically competent, trained and/or qualified personnel.

Technically competent, trained and qualified personnel are defined as follows:

- possessing sufficient knowledge in a specific field based on their specialized training and experience
- familiar with work safety and accident prevention regulations (lock-out/tag-out safety procedures)

Personal Protective Equipment

	CAUTION! Oils, lubricants and cleaning agents can cause skin reactions and irritation. Hot surfaces, hot oil and/or caustic media can cause severe burns or acid burns.
	Avoid skin contact. Wash your hands properly each time after coming into contact with these substances.
	Wear protective equipment especially when you are performing any maintenance, inspection and cleaning tasks!
	

Safety Measures at Installation Location

Place the pump on a level, stress-free foundation or frame.

Secure piping sufficiently by means of supports or retaining clamps. Clean the piping.

Use appropriate local instructions and checks to ensure that the surrounding area of the workplace is clean and tidy at all times.

Protective Devices

Do not allow the Plexiglas covers on the gear/drive unit and on the pump head to come in contact with any gear and/or hydraulic oil.

Protective panels on the couplings prevent access to rotating parts.

EMERGENCY-OFF switches on the pump can be used to shut down the pump immediately in the case of an emergency or malfunction.



EMERGENCY-OFF switches are not part of the scope of delivery of SPX PROCESS EQUIPMENT! The owner-operator must provide EMERGENCY-OFF switches and install them at suitable locations.

The EMERGENCY-OFF switches should be readily accessible and clearly visible.

Protective devices

- are installed for the safety of operating personnel.
- are not allowed to be modified, removed or bypassed by means of any modifications on the pump.

Behavior in Case of Emergency

An emergency exists whenever human life is endangered and/or other general risks exist. The source of danger can be the pump itself or originate from conditions in the surrounding area.

In the case of an emergency or malfunction, the pump must be switched off immediately.

The pump cannot be put into operation again until the malfunction has been identified and corrected, and corrective actions taken to prevent future occurrences.

In case of fires, use only suitable fire-extinguishing agents.

Warn other personnel in the case of any danger – even when the danger is only presumed.
Stay calm!

2 Product Attributes

2.1 ProCam^{MD}



CAUTION!

Gear unit damage possible!

Do **not** operate the pump in systems equipped with cathodic corrosion protection. Do **not** use the pump as a cooling unit for liquids, for the compression of gases or as a generator.

Construction of the Metering Pump

The metering pump is a reciprocating positive displacement pump. Basic components are the drive (A), the stroke length adjustment (B), the pumphead (C), and the gear unit (D) (Fig. 2.1).

The functions of the components are described in section 3 (Assembly Groups).



The design of the metering pump fulfills European safety and accident prevention regulations.

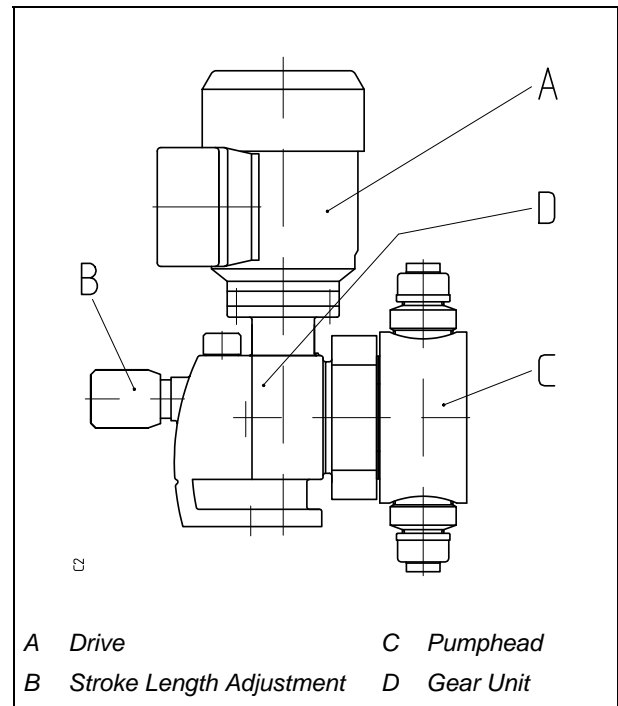

Fig. 2.1: Metering Pump

Safety Instructions

**WARNING!**

Burns and other forms of injury to health may occur due to hot, dangerous medium.

Also, increased wear and tear on the pump head and on the gear unit can result.

Whenever the system design pressure is exceeded, the pipeworks can tear apart and hot or dangerous medium can then be sprayed out.

Take the necessary measures to prevent the permissible maximum design pressure from being exceeded, e.g. by installing a safety valve. (see *Section 4.3*)

Before starting to work on the metering pump check carefully that

- all pressurized parts (pumphead, piping) are depressurized
- the drive is disconnected from the power source
- personal protection is carried out according to local regulations
- parts being used in contact with aggressive substances are flushed before handling
- For safe operation of the bleed valve see *section 3.5 (Bleed valve for product chamber)*.

The maximum allowable operating temperature depends on the suitability of the materials and lubricants in use.

3 Assembly Groups

3.1 Gear Unit

3.1.1 Gear Models G1 and G2 for ProCam MD

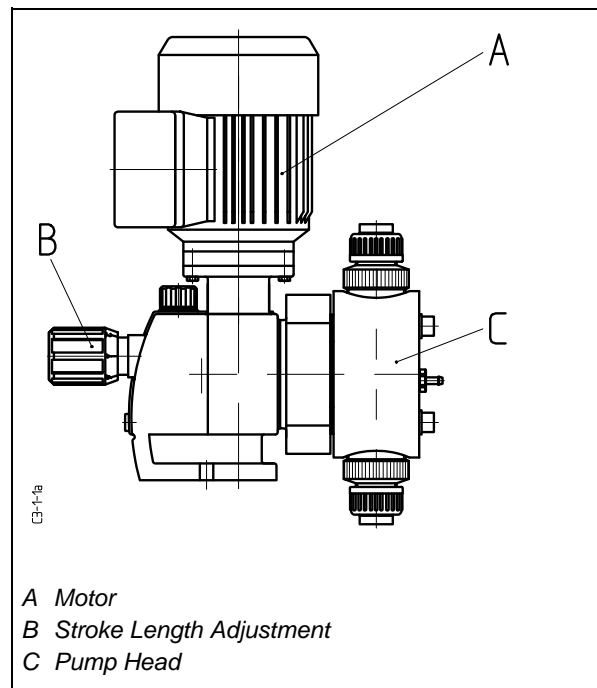

Fig. 3.1: Plan View (Main Gear G1, G2)

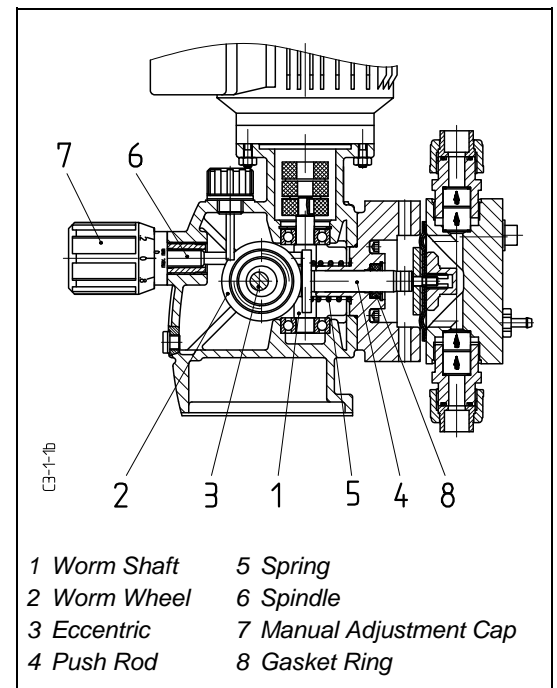

Fig. 3.2: Sectional View (Main Gear G1, G2)

Construction and function

For the construction and function of models G1 and G2 see Fig. 3.1 and 3.2.

The rotary motion of the motor (A) is transmitted by the worm shaft (1) and the worm wheel (2) to the fixed eccentric (3) which shifts the push rod (4) to the front dead center. The spring (5) shifts the push rod back to the rear dead center. At full stroke setting the eccentric does not lose contact to the push rod.

Part-stroke settings are achieved with a "lost motion device" consisting of a spindle (6), which is connected to a manual adjustment cap (7). A clockwise rotation of the spindle displaces the rear dead center of the push rod and the eccentric temporarily loses contact to the push rod. At zero setting, the rear dead center coincides with the front dead center and consequently the push rod cannot be shifted by the eccentric. To prevent leakage of gear fluid, the push rod is sealed with a gasket ring (8).

Suction and discharge strokes are both positive mechanical movements, but the suction stroke could be limited if the return spring is damaged or broken.

Stroke Length Adjustment (B)

See section 3.2.

Oil Filling



ATTENTION!

Gear unit damage possible due to impermissible temperature rise and wear and tear!

The gear/drive units are delivered without being filled with oil.

Fill with oil prior to the putting into service procedure (see *Section 5.1 and 5.2*).

3.2 Stroke Length Adjustment

3.2.1 Manual Stroke Length Adjustment at Standstill and in Operation for Gear Models G1 and G2

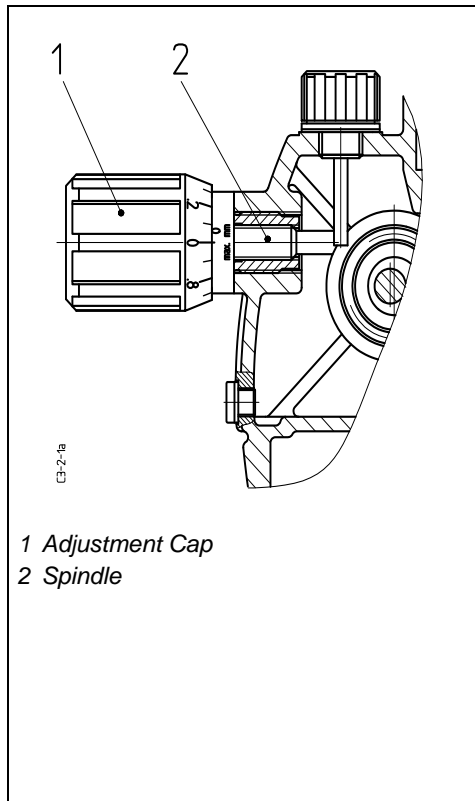

Fig. 3.1: Sectional View

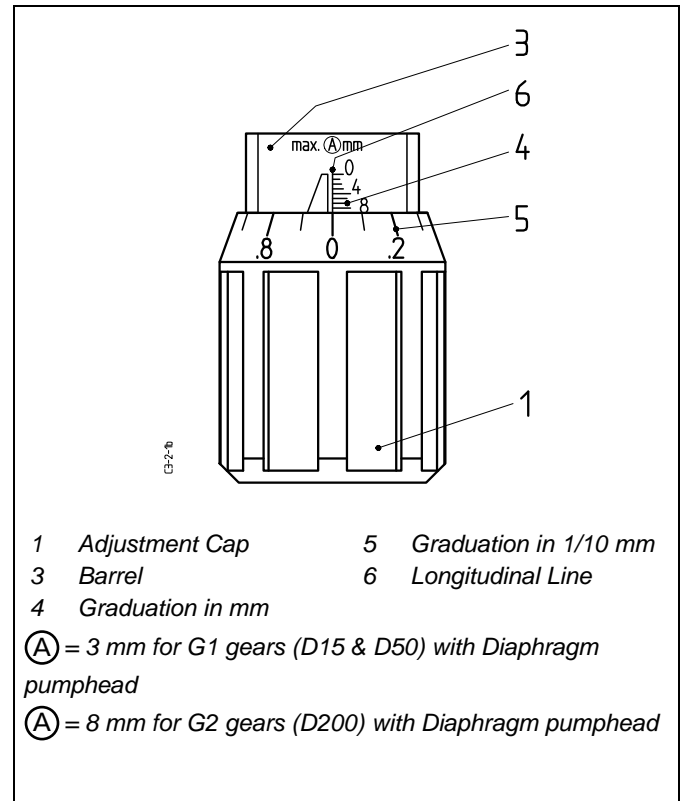

Fig. 3.2: Plan View

Construction and Function

The micrometer adjustment cap (1) is connected to the spindle (2). A clockwise rotation of the adjustment cap (1) displaces the rear dead center of the push rod towards the front dead center via the spindle. As a result, the stroke length is reduced.

A counterclockwise rotation of the adjustment cap (1) increases the stroke length.

(See Fig. 3.1).

Adjustment of the stroke length

	<p>WARNING!</p> <p>Damage in the gear unit possible.</p> <p>Do not screw the micrometer adjustment cap beyond the zero or the displayed maximum setting !</p>
---	--

A rotation of the micrometer adjustment cap (1) varies the delivery setting of the pump. The setting can be changed with the pump operating or at rest.

The micrometer barrel (3) is inscribed with circumferential graduations (4), which indicate the stroke length in mm.

The micrometer adjustment cap is graduated in 1/10 mm (5).

To obtain, e.g. 6.8 mm stroke length setting, rotate the micrometer adjustment cap until the 6 mm graduation is just visible with the ".8" graduation on the adjustment cap coinciding with the longitudinal line on the barrel. It can similarly be set up to any stroke length required.

(See Fig. 3.2)

Adjustment of capacity see section 5.4.

3.3 Pump Head

3.3.1 Diaphragm Model

Construction and Function

The double diaphragm (5, 6) clamped at the circumference between cover (1) and yoke (2) and in the center between medium side disc (7) and atmospheric side disc (8), separates hermetically the product chamber (A) from the atmosphere (B). The eccentric drives via the push rod (9) the double diaphragm (5, 6) and transmits its movement to the liquid in the product chamber (A).

The suction (4) and discharge valves (3) are self-acting valves. They are operated by pressure differences of the product chamber (A) and the discharge and suction pressures.

- **Suction stroke:** Movement from front (Fig. 3.1) to rear dead center (Fig. 3.2).

During the suction stroke the difference between the suction pressure and the pressure in the product chamber (A) causes the suction valve (4) to open so that the product chamber (A) is filled with product.

- **Discharge stroke:** Movement from rear (Fig. 3.2) to front dead center (Fig. 3.1).

During the discharge stroke the pressure in the product chamber (A) increases until it exceeds the discharge line pressure and the opening pressure of the discharge valve (3). Then the flow medium is discharged from the product chamber (A) into the discharge line.

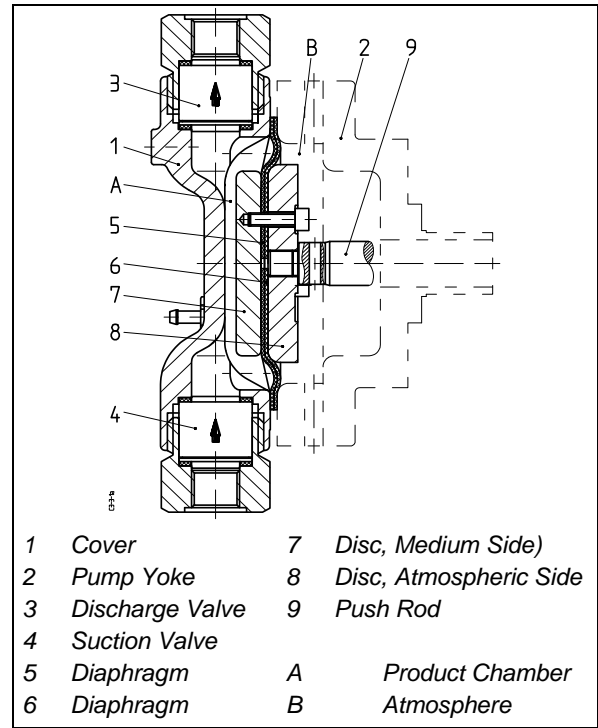

Fig. 3.1: Diaphragm at Front Dead Center

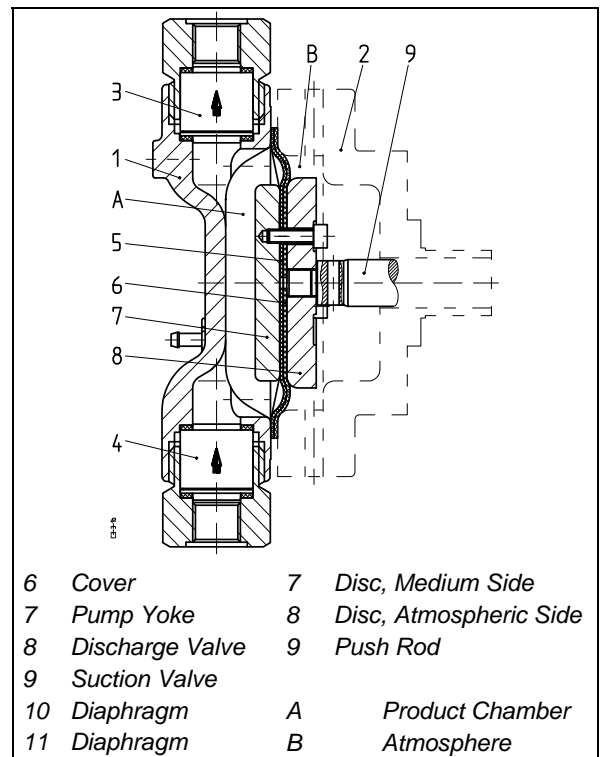

Fig. 3.2: Diaphragm at Rear Dead Center

3.3.1.1 Double Diaphragm Assembly and Diaphragm Rupture Monitoring Device

The double diaphragm arrangement (Fig. 3.3) consists of two diaphragms (5, 6) clamped between medium side (7) and atmospheric side (8) discs.

Within the mounted pump head (Fig. 3.3), a connection exists from the inner contact area between the two diaphragms through the groove (C) in the atmospheric side diaphragm (6), a bore in the medium side diaphragm (5) and the bore (D) in the cover (1) to the hose nipple (10), the pressure gauge (11) or the pressure switch (12).

Damage of the medium side diaphragm (5) results in an increase of pressure between the diaphragms, thus causes liquid escape via the hose nipple (10) into a hose or indicates pressure increase at the pressure gauge (11) or pressure switch (12).

The signal of the pressure switch (12) can be used either to stop the metering pump or to have an audible signal.

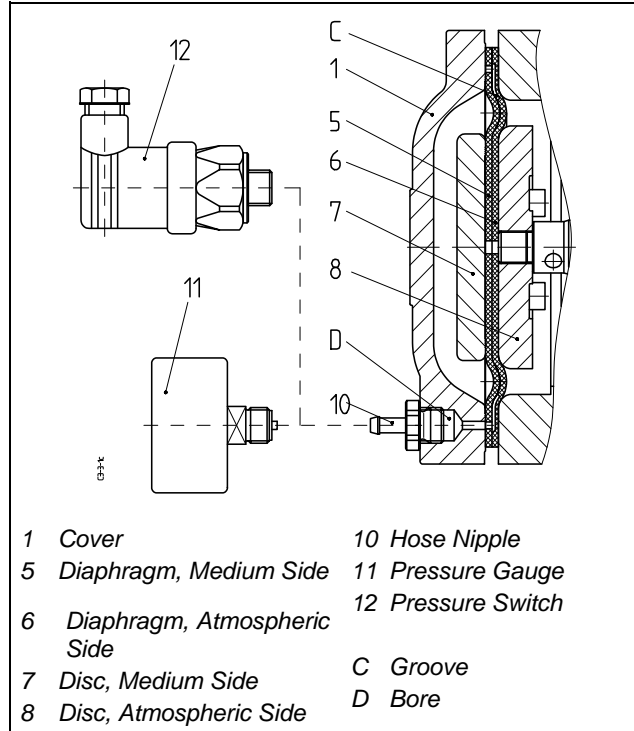

Fig. 3.3: Diaphragm Rupture Monitoring Device

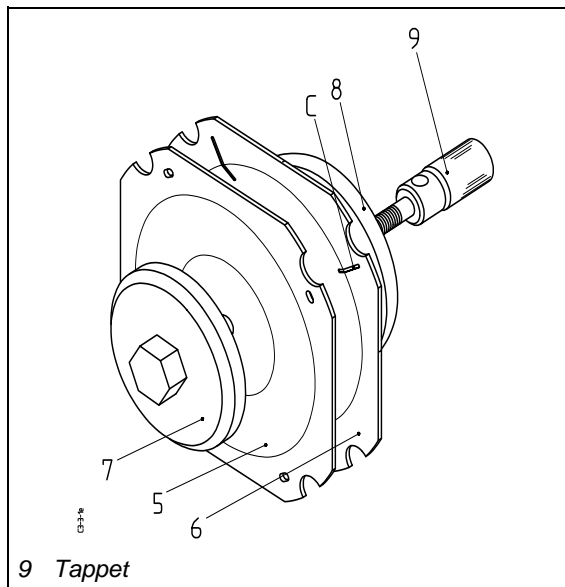

Fig. 3.2: Double Diaphragm arrangement for Pump Head (Gear Models G1: D15 & D50)

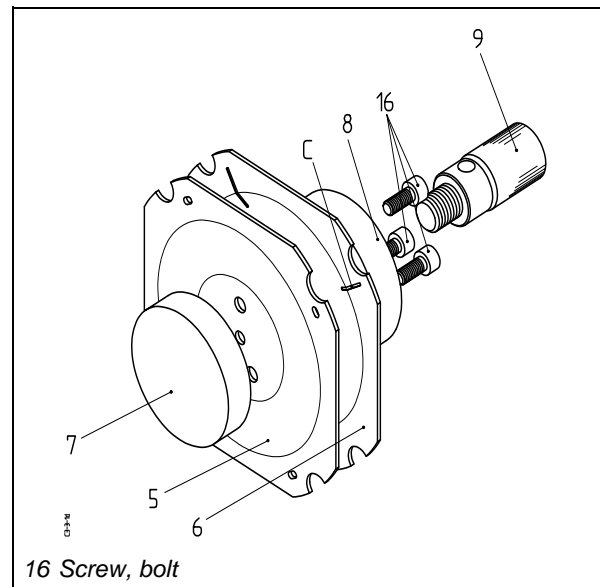

Fig. 3.3: Double Diaphragm arrangement for Pump Head (Gear Models G2: D200)

3.3.1.2 Replacement of the Diaphragm, Gear Model G1 (MD15, MD50)

The replacement of the diaphragm from the gear models G1 is shown in *Fig. 3.6* and *Fig. 3.7*.



See assembly drawings in section 9.

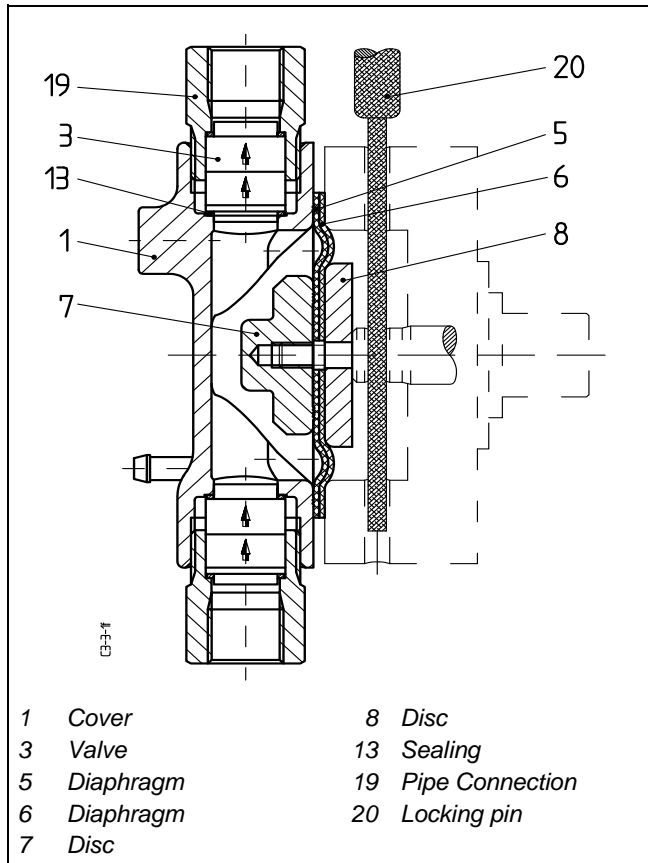

Fig. 3.6: Sectional View

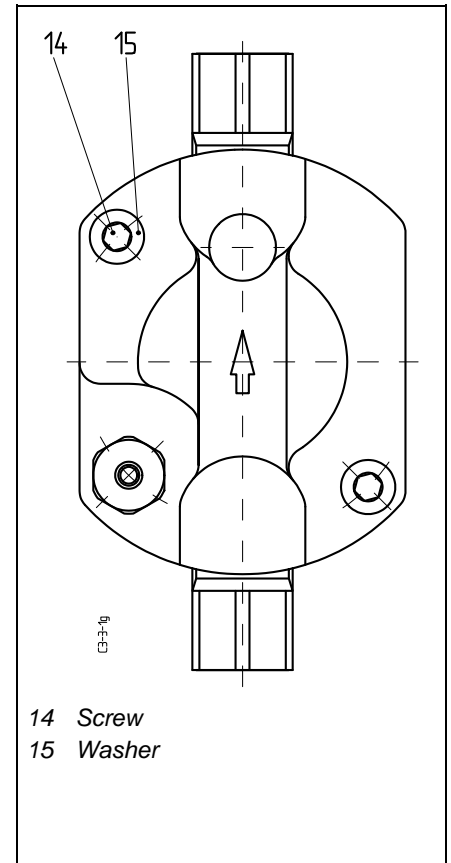

Fig. 3.7: Plan View

Removal



Notice the safety instructions in section 2 "Product Attributes"!

- Flush the pump head.
- Close the suction and discharge lines.
- Loosen the pipework.
- Extract the screws (14) uniformly and remove the cover (1).
- Set the gear to "0" mm stroke length and the rod will be in the top dead center position.
- To prevent movement of the push rod insert a screw driver or a locking pin through the bores in the yoke and push rod (see Fig. 3.6).
- Dismantle the double diaphragm by unscrewing the disc (7).
- Remove the connected rupture monitoring device. Check and clean. Replace if damaged

	<p>ATTENTION!</p> <p>In case of a diaphragm rupture the complete double diaphragm must be replaced !</p>
--	--

	<p>ATTENTION!</p> <p>If both diaphragm layers are ruptured, process fluid will have entered the yoke!</p> <p>Please flush and clean carefully. Replace push rod, if corroded.</p>
--	--

Assembly

- Set the gear to "0" mm stroke length.
- To prevent movement of the push rod insert a screwdriver or a locking pin through the locating bores in the yoke and push rod!
- Clean and make all concentric grooves in the cover (1) and disc (7) free of liquid!
- Relocate disc (8), double diaphragm (6, 5) and locking disc (7) consecutively. Locate the double diaphragm by inserting the screws (14).
- Tighten disc (7) to the required torque (see assembly drawing, section 9).
- Remove screws (14).
- Fit the front cover (1), relocate screws (14) and tighten to the required torque (see assembly drawing).
- Fit the diaphragm rupture monitoring device.

	<p>WARNING!</p> <p>Risk of injury caused by the loaded spring inside the gear.</p> <p>If the pump yoke (2) is dismantled, the push rod (9) must be fixed to the yoke (2) by inserting a suitable tool (20) (screw driver or locking pin) through the locating bores in the yoke and the push rod (9).</p>
--	--

3.3.1.3 Replacement of the Diaphragm, Gear Model G2 (MD200)

The replacement of the diaphragm from the gear unit models G2 is shown in *Fig. 3.8 and Fig. 3.9*.



See assembly drawings in the section 9.

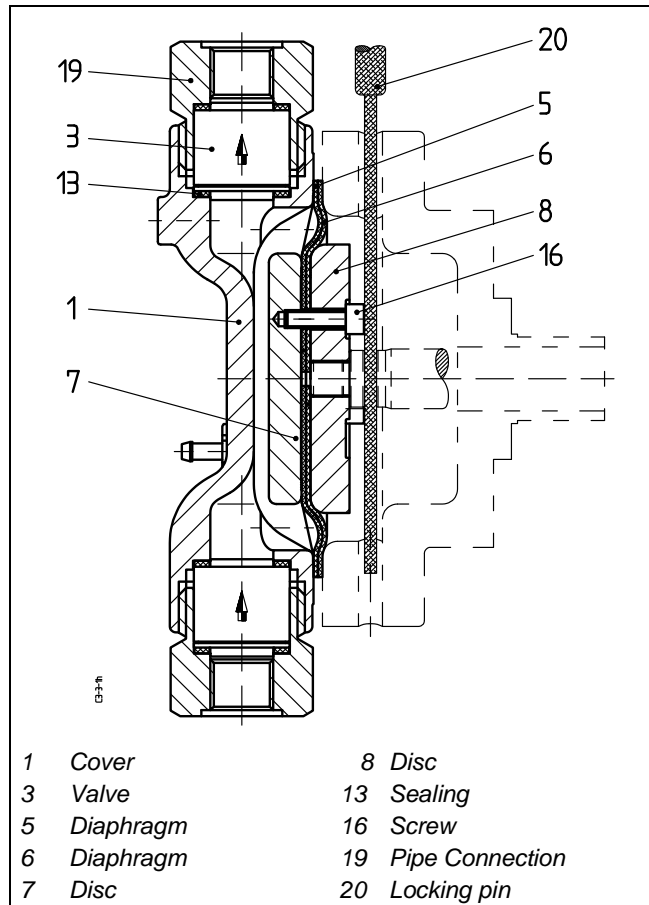

Fig. 3.8: Sectional View

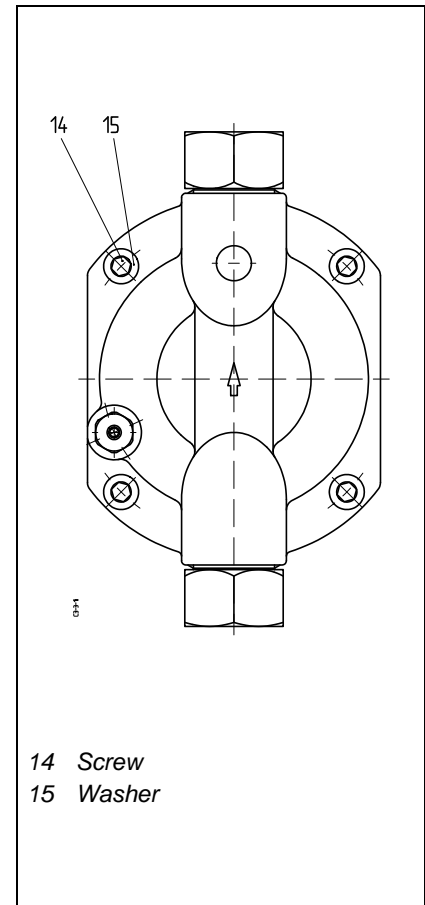

Fig. 3.9: Plan View

Removal



Notice the safety instructions in section 2 "Product Attributes"!

- Flush the pump head.
- Close the suction and discharge lines.
- Loosen the pipework.
- Extract the screws (14) with washers (15) uniformly and remove the cover (1).
- Set the gear to "0" mm stroke length and the rod will be in the top dead center position.
- To prevent movement of the push rod insert a screw driver or a locking pin (20) through the bores in the yoke and push rod. (see Fig. 3.8).
- Unscrew counterclockwise (CCW) the diaphragm assembly (5, 6, 7, 8, 16) and dismantle.
- Remove the connected rupture monitoring device. Check and clean. Replace if damaged.

	<p>ATTENTION!</p> <p>In case of a diaphragm rupture the complete double diaphragm must be replaced !</p>
---	--

	<p>ATTENTION!</p> <p>If both diaphragm layers are ruptured, process fluid will have entered the yoke!</p> <p>Please flush and clean carefully. Replace push rod, if corroded.</p>
--	---

Assembly

- Set the gear to "0" mm stroke length.
- To prevent movement of the push rod insert a screwdriver or a locking pin through the locating bores in the yoke and push rod!
- Clean and make all concentric grooves in the cover (1) and disc (7) free of liquid!
- Assemble diaphragm assembly. Coat screw (16) with Loctite, insert and tighten to required torque (see assembly drawing, section 9).
- Relocate diaphragm assembly to the push rod. Tighten clockwise (CW) finger-tight. At max. position loosen until alignment with yoke bores.
- Fit the front cover (1), relocate screws (14) and tighten to the required torque (see assembly drawing).
- Fit the diaphragm rupture monitoring device.

	<p>WARNING!</p> <p>Risk of injury caused by the loaded spring inside the gear.</p> <p>If the pump yoke (2) is dismantled, the push rod (9) must be fixed to the yoke (2) by inserting a suitable tool (20) (screw driver or locking pin) through the locating bores in the yoke and the push rod (9).</p>
---	--

3.4 Valves

Assignment: Pump head (Fig. 3.1).

For the valve used in the pump head see “drawings and parts lists” in section 9.

Function

Suction and discharge valves are self acting valves. They are operated by pressure differences between the product chamber and the suction and discharge lines respectively.

See also section 3.3

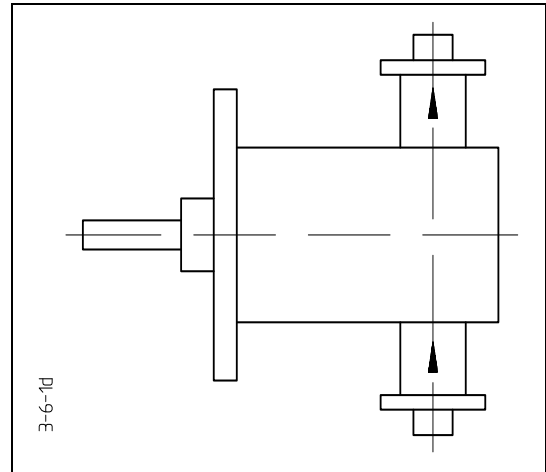



Fig. 3.1: Pump Head

Mounting



CAUTION!

Personal and property damage possible!

Incorrect installation of the valves will lead to diaphragm rupture or pump head failure.

Pay attention to the direction arrow of the valves (see Fig. 3.1 to 3.6)

Pay attention to the direction arrows on the valves when installing.

- **Suction valve:** arrow points to the product chamber
- **Discharge valve:** arrow points away from the product chamber

3.4.1 Ball Model

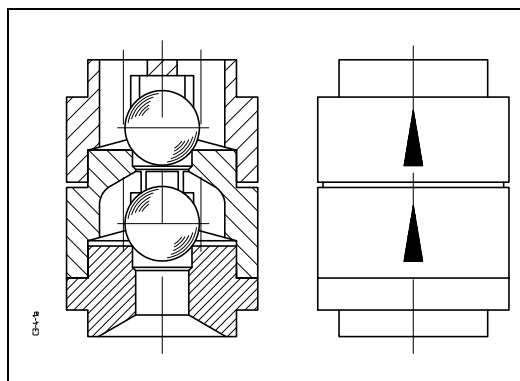

Fig. 3.2: Double Ball Valve - Sectional and Plan View

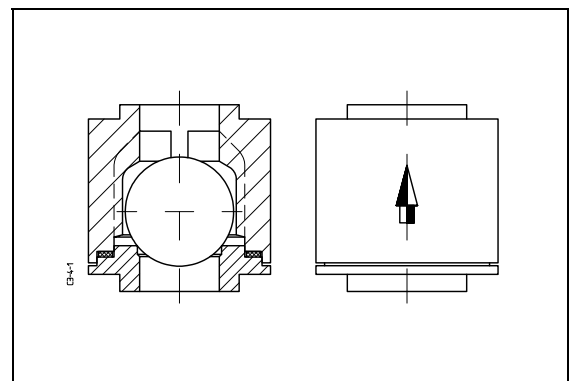

Fig. 3.3: Single Ball Valve - Sectional and Plan View

3.5 Bleed Valve for Product Chamber

3.5.1 Diaphragm Pumphead

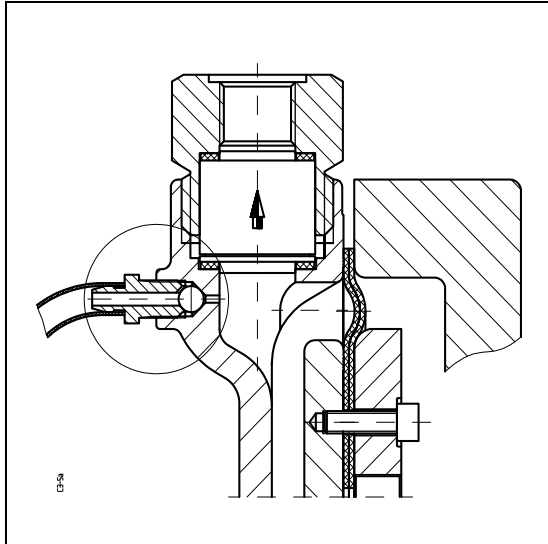

Fig. 3.1: Fitting Position

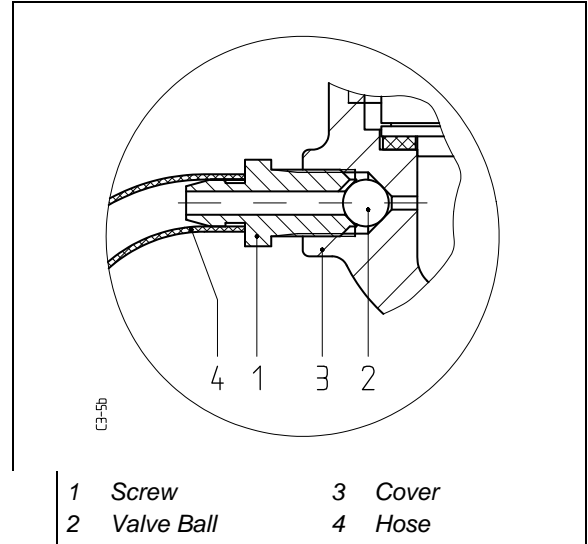

Fig. 3.2: Bleed Valve

- | | |
|--------------|---------|
| 1 Screw | 3 Cover |
| 2 Valve Ball | 4 Hose |

Fitting Position

Fig. 3.1 shows the fitting position of the bleed valve, which is located near the highest point of the product chamber. Any gas present in the product chamber can be discharged through the bleed valve.



The screw (1) is sealed with PTFE-tape.

Function of the bleed valve

Gas existing in the product chamber can be discharged through the bleed valve (Fig. 3.2):

- **Bleed valve shut:**

Screw (1) presses the valve ball (2) into the valve seat in the cover (3). Gas or flow medium cannot discharge in this state.

- **Bleed valve in operation:**

Loosen the screw (1) approx. 1/2 a turn. During the suction stroke, the valve ball (2) now closes the valve automatically. During the discharge stroke the bleed valve is opened so that gas or flow medium can discharge.

When product discharges through the bleed valve, tighten the screw (1).

**WARNING!**

Toxic or aggressive media to be conveyed can cause serious eye and skin injuries.

Gas or medium to be conveyed flows out whenever the bleed valve is opened.

Discharge this medium via the connection (4).

Use a suitable collecting container.



Avoid skin contact.

Wash your hands properly each time after coming into contact with these substances.

Wear protective equipment and, whenever necessary, a gas mask!

4 Installation

4.1 Installation

Prior to Installation

- Check the packing of the metering pump for external damage. Open the package.
- Check metering pump and accessories for external damage.



SPX PROCESS EQUIPMENT must be notified about any form of damage immediately.

Installation Location

Unless no other installation conditions have been agreed, the installation procedure must be carried out in dry rooms without aggressive atmospheres.

In the case of outdoor installation, a form of protection against precipitation, sandstorms and direct sunlight must be provided.

The ambient temperature is not allowed to be below -20°C or above +40°C.

Foundation and Installation

The height of the foundation should be selected so that it is easy to carry out any operating and maintenance tasks.

Stroke length adjustment, stroke length display (if available), oil filling and oil draining, oil level inspection and plunger sealing must be easily accessible.

During the installation procedure, make sure that sufficient clear space for maintenance work (e.g. for lifting equipment for dismantling operations during repair work) is available around and above the metering pump.

- Place the metering pump *stress-free* on a foundation, frame, etc.



ATTENTION!

Especially when at standstill, the roller bearings in the pump can become damaged by adjacent equipment units.

Protect these roller bearings against vibrations by means of a suitable (vibration-damping) foundation.

- Use fastening screws to screw the pump onto the fastening holes. Adjust the pump so that the plunger axis is in horizontal position and the valve axis in vertical position.

Electrical Connection



DANGER!

Electric shocks can kill you!

All tasks on the electrical equipment are only allowed to be carried out by expert electrical personnel!

Electrical connections must comply with local regulations.

- **Dangerous voltages can be present due to faulty ground connections. Carry out all these tasks only when the system is in de-energized condition.**
- **Prevent electrostatic charging. Connect all electrically conductive parts safely to the equipotential bonding device.**
- **If not included in the scope of supplies, install an EMERGENCY-OFF device. Without an EMERGENCY-OFF device, accident prevention is not sufficiently guaranteed in the case of malfunction or incorrect operation of the pump by the user.**
- **Use only those types of EMERGENCY-OFF switches that correspond to the equipment safety class.**
- **Provide overload protection or temperature monitoring.**

- Check the voltage, frequency, speed and output.
- Take the direction of rotation of the drive unit into account.

Connection of the Pipeworks

- Clean the pipeworks properly before connecting them.
- Connect the pipeworks stress-free.
- Connect the pipeworks so that it is easy to remove the valve and dismantle the pump head.
- Support the pipe weights by means of retaining clamps.
- Compensate pipe expansions by means of pipe bends.



CAUTION!

Personal and property damage possible!

Reciprocating positive-displacement pumps can cause vibrations in the case of freely suspended pipework sections. Pipeworks can tear off and could result in serious injury to personnel.

Fasten the pipeworks at a sufficient number of different points with supports and/or retaining clamps.

Do not use pipeworks as a climbing aid!

4.2 Suction and Discharge Lines

WARNING!

The suction and discharge lines must be properly designed and connected to the pumphead.

Otherwise the pump can be seriously damaged!

The suction and discharge lines should be designed so as to prevent cavitation, excess load or excess feeding, caused by the pulsating flow of the metering pump.

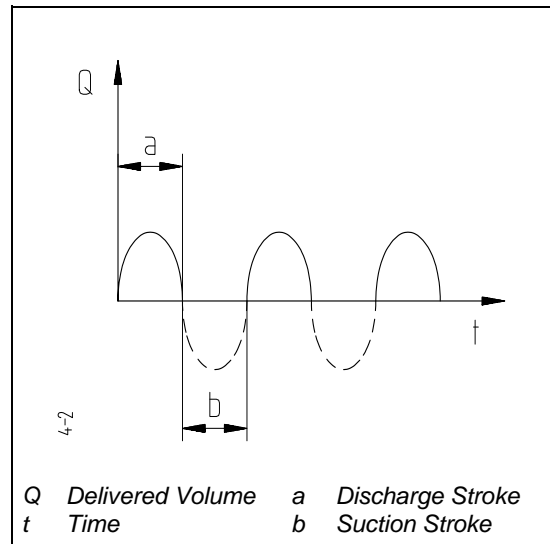

Fig. 4.1: Delivered Volume of a Single Pumphead

Prevent	Cause	Result	Remedy
Cavitation	<ul style="list-style-type: none"> suction pressure falling below the vapor pressure of the product 	<ul style="list-style-type: none"> loud noise excessive valve wear excess load 	<ul style="list-style-type: none"> avoid high suction lifts keep the pipe length short
Excessive Load	<ul style="list-style-type: none"> pressure peaks exceeding the operating pressure 	<ul style="list-style-type: none"> fatigue failure forced rupture 	<ul style="list-style-type: none"> sufficient nominal diameters use of pulsation dampers
Excessive Discharge	<ul style="list-style-type: none"> suction or discharge line too long suction pressure is higher than discharge pressure pressure sustaining valve missing 	<ul style="list-style-type: none"> inaccurate metering loud noise excessive valve wear 	<ul style="list-style-type: none"> use of a pressure sustaining valve decrease viscosity

If required, SPX PROCESS EQUIPMENT will check the system isometrics. For this, the following information must be given:

Product characteristics:

- Density
- Vapor pressure at operating pressure
- Viscosity
- Settling speed, if product is a suspension

Installation data:

- Geodetic height
- Pressures on the suction and discharge side
- Length of the pipework
- Nominal diameter
- Number of pipe bends
- Fittings
- Isometrics

4.3 Installation - Examples

4.3.1 Suction and Discharge Piping

The recommended accessories for the installation on the suction and discharge side are listed in Fig. 4.1:

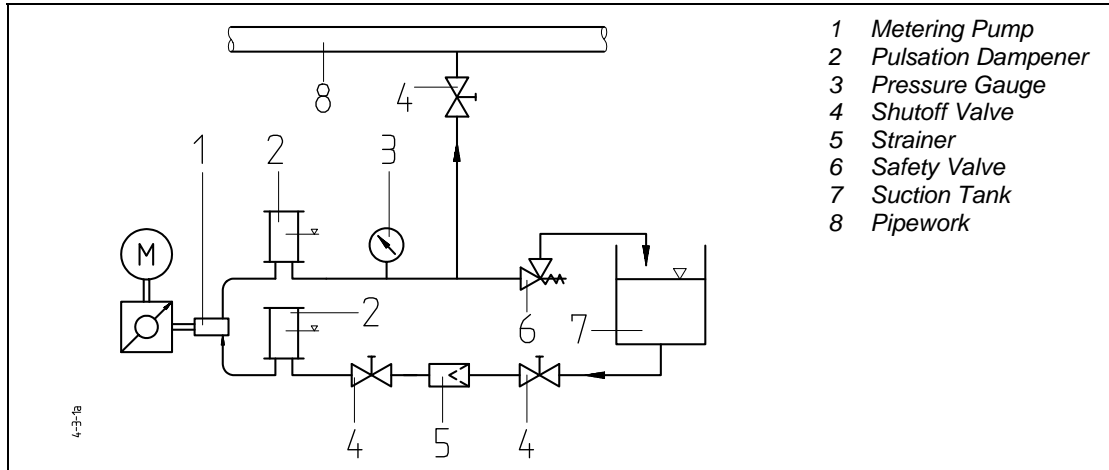



Fig. 4.1: Suction and Discharge Piping



ATTENTION!
 To avoid personal injury and damage to the pump or related equipment, we recommend to install a safety valve!

Installation of the Safety Valve (Fig. 4.2)

Aim:
 Prevent overload of the pump.

Position:
 Between the discharge flange and the first shutoff valve in the discharge line or behind the pulsation dampener if applicable.

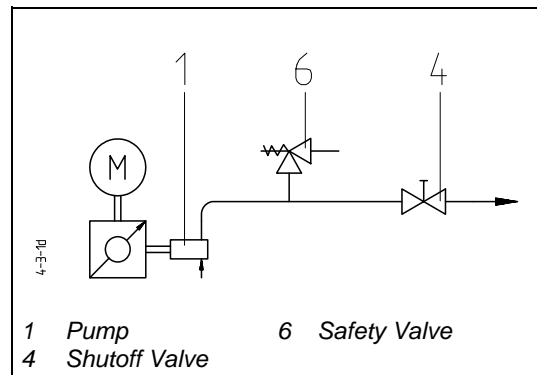

Fig. 4.2: Safety Valve

Mounting of Pulsation Dampers (Fig. 4.3)

Aim:
Dosing with less pulsations;
prevent cavitation and overload.

Position:
Just in front of the suction
flange and behind the discharge
flange of the pumphead.

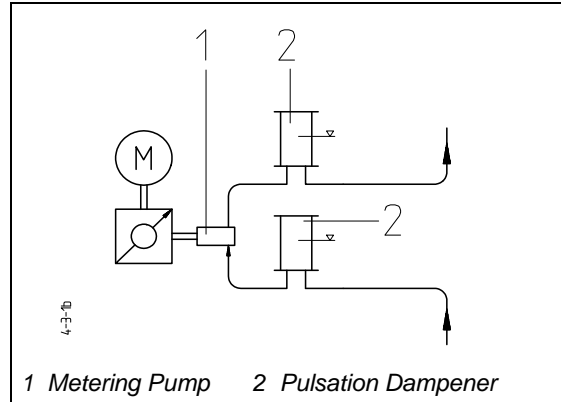

Fig. 4.3: Pulsation Dampener

Installation of the Pressure Sustaining Valve (Fig. 4.4)

Aim:
Prevent of excessive discharge
and excessive mass
acceleration.

Position:
Vertically at the end of the
discharge line.

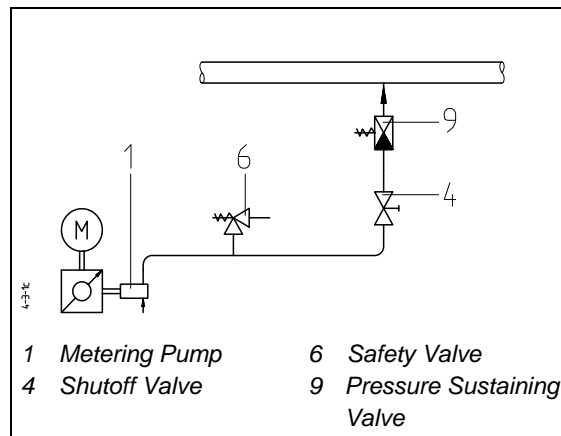

Fig. 4.4: Pressure Sustaining Valve

Installation of a Foot Valve (Fig. 4.5)

Aim:
Prevent draining of a long
suction line.

Position:
Vertically near the bottom of the
reservoir.

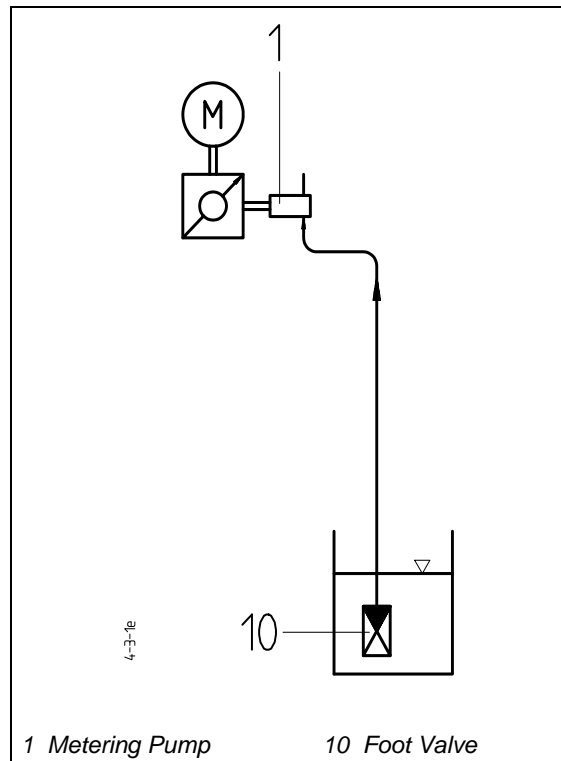

Fig. 4.5: Foot Valve

**Installation of a Surge Tank
(Fig. 4.6)**

Aim:
Prevent suction lift.

Position:
Same level as the metering pump.

Filling:
Using a feed pump (12) with max./min. control.

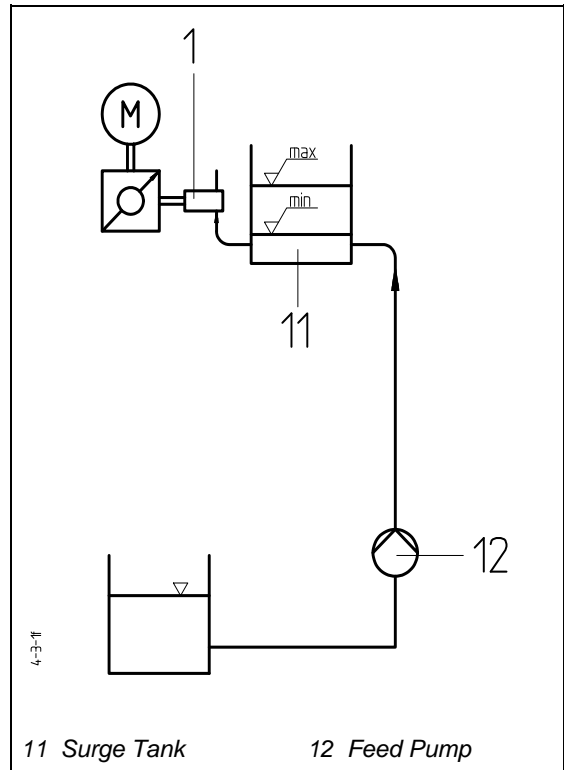
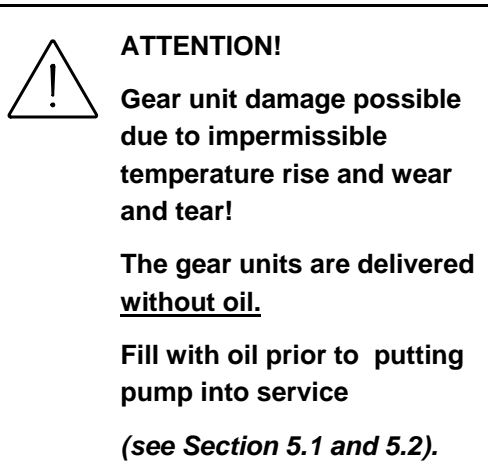

Fig. 4.6: Surge Tank

5 Operation

5.1 Lubricant and Lubricant Change

Gear Unit



the following instructions
see Fig. 5.1 and 5.2:

First Filling

- Unscrew the oil dipstick (1).
- Fill with required amount of oil.
- Screw in the oil dipstick (1).
- Start motor (A) for a short period.

Checking the Oil Level

- Shut off the motor (A).
- Unscrew the oil dipstick (1) and wipe off the oil.
- Screw in the oil dipstick (1) and unscrew it again.
- The oil level should be between max. and min.
(see Fig. 5.2).
- In case of an oil gauge the oil level should be visible in the middle of the gauge.

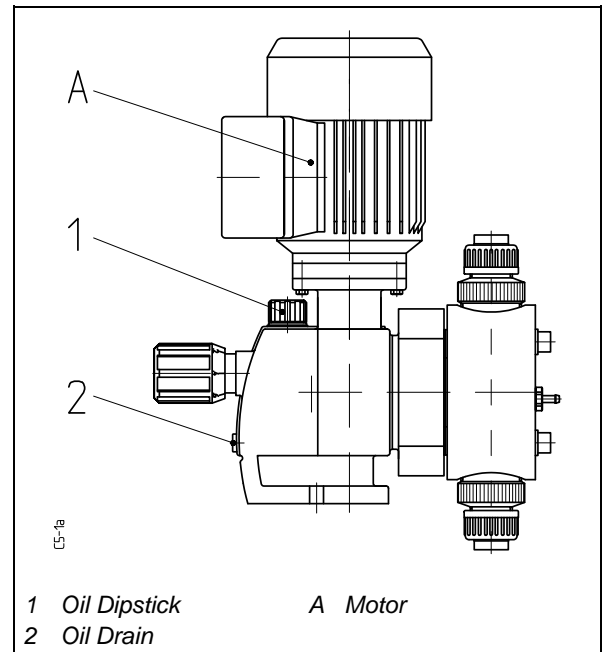

Fig. 5.1: Plan View, e.g. Gear G1

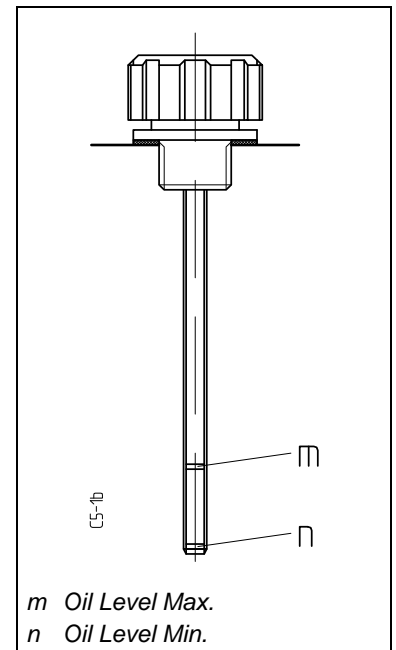





Fig. 5.2: Oil Dipstick

Oil Change

Change the oil after the first 300 hours of operation and then after every 4000 hours.

Oil Draining

	CAUTION! Gear oil heats up during normal operation and can be sprayed out when being drained. Severe burns in the face and on the hands possible.
	Avoid skin contact. Wash your hands properly each time after coming into contact with gear oil. Wear protective equipment! Use sufficiently large collecting containers.
	
	

Open the oil drain (2) and drain the oil.

Oil Filling

See above "First Filling".

5.2 Oil Quality and Quantity for Gear Unit G1 and G2

At approx. 40 °C (104°F), use oils with a nominal viscosity of 80 to 150 cst (ISO VG 80 – 150).

See *table 5.1*: below for examples of suitable oils:

Model	Type	Vol – Ltr. (Qt.)
MD15 MD50	G1	0.5L (0.53Qt.)
MD200	G2	0.8L (0.85Qt.)

Table 5.2: Oil Volume for Gear Unit

Brand	Brand name
ARAL	Aral Degol BG 100
BP	BP Energol GR-XP 100
ESSO	Sparten EP 100
FUCHS	Renep Compound 103
MOBIL	Mobilgear 627
SHELL	Shell Omala Öl 100
TEXACO	Meropa 100
DEA	Astron HLP 100 Falcon CLP 100
Wintershall	Ersolan 100

Table 5.3: Oil Quality for Gear Unit

5.3 Start-up Procedure

Consider the following points before starting the metering pump:

- Check oil filling (see section 5.1).
- Readjust stroke length, if necessary, e.g. after transport (see section 3.2).
- Check if the metering pump is protected against overload. For safety valves see section 4.3.1.

Electrical Connection



DANGER!
Electric shocks can kill you!
The motor must only be connected by qualified personnel!

- Connect drive motor (1).
- Check the direction of rotation of the drive motor (1). An arrow on the fan cover of the motor and the gear unit indicates the direction of rotation (see Fig. 5.1).

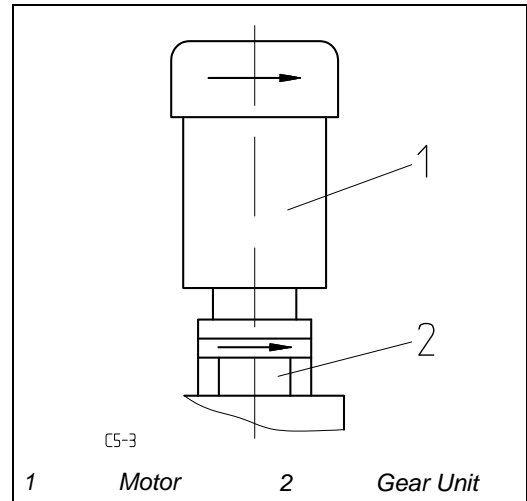



Fig. 5.1: Direction of the Motor Rotation



ATTENTION!
An enormous rise in pressure can result in an impermissible build-up of heat in the pump head and cause damage to parts of the pump head.

- Do not start up the pump with closed shut-off valves in the pressure and suction piping.
- Install a safety valve in the pressure piping.
- Do not close the shut-off valves in the pressure and suction piping whenever the pump is still in operation.

For machines with frequency converters, the following information applies:
Do not change any data (frequency range and torque characteristics) adjusted by SPX PROCESS EQUIPMENT until you have consulted with SPX PROCESS EQUIPMENT first!

Start-up procedure

- Open all shutoff valves in the suction and discharge lines.
- If heating or cooling is necessary, open all shut-off valves in the supply lines.
- Make sure that there is sufficient product.
- Adjust the stroke length to "0".
- If the motor speed is variable, set motor (1) to lowest speed.
- Start drive motor.
- Slowly increase speed and stroke length to the maximum.
- If possible, operate the metering pump at minimum discharge pressure for good venting of the pipework.
- Check the pipework and the packing of the pump for leaks during the start-up procedure.

If the suction head is too high and the metering pump does not prime,

- increase the suction pressure or
- reduce the suction lift, *see section 4.3.1.*

When suction and discharge lines are filled and vented,

- slowly increase the pressure up to the operating pressure
- adjust speed and stroke length to the required values.

5.4 Adjustment of the Capacity

The stroke length to be adjusted for a required capacity is calculated from the max. stroke length, the capacity required and the max. capacity. The max. capacity is calculated by BRAN+LUEBBE from:

- an assumed volumetric efficiency of 98 % and
- the number of strokes that result from the nominal speed of the motor.

Under normal operating conditions, it is sufficient to calculate the stroke length according to the following equation:

$$\text{stroke length (mm)} = \text{max. stroke length (mm)} \times \frac{\text{capacity required (l/h)}}{\text{max. capacity (l/h)}}$$

or

$$\text{stroke length (\%)} = 100 \% \times \frac{\text{capacity required (l/h)}}{\text{max. capacity (l/h)}}$$

max. stroke length: *refer to section 9, table 9.1*

max. capacity: *refer to section 9, table 9.1*

capacity required: given by the user of the metering pump

Example

For the example, the following values are assumed:	max. stroke length:	8 mm
	max. capacity:	245 l/h
	capacity required:	200 l/h

$$\text{stroke length} = 8 \text{ mm} \times \frac{200}{245} = \underline{\underline{6,53 \text{ mm}}}$$

or

$$\text{stroke length} = 100 \% \times \frac{200}{245} = \underline{\underline{81,6 \%}}$$

Under special operating conditions, however, such as

- high operating pressures and
- small diaphragm/plunger diameters,

the stroke length calculated above should be corrected since the actual capacity is dependent on operating conditions such as operating pressure, viscosity, length of suction and discharge lines, arrangement etc. Thus an exact relationship between stroke length and capacity can only be determined under operating conditions.



In case of normal operating conditions you don't need to follow the procedure described below and can directly proceed with *section 5.4.1*.

Correction of Stroke Length by Determining the Actual Capacity

To determine the actual capacity, measure

- the volume per 100 strokes and
- the actual stroke frequency.

Two ways of measuring the volume are described below:

Measuring the Volume on the Suction Side (Fig. 5.1)

Prior to the measurement:

- Fill and vent the suction and discharge lines prior to measurement.
- Operate the pump for a short time
- Adjust the stroke length to 6,53 mm or 81,6 % as calculated in example 1.

Measurement

- Open shutoff valves (3) and (4).
- Fill up burette (2).
- Close shutoff valve (4).
- Read volume drawn from the burette (2) for 100 strokes.

$$\text{measured volume} = V_{100 \text{ strokes}} (\text{cm}^3)$$

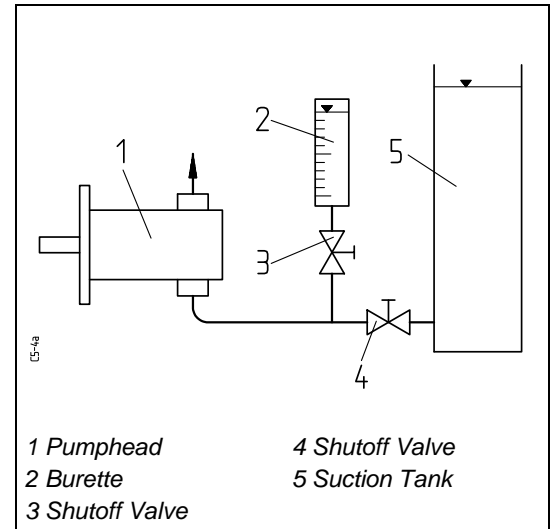

Fig. 5.1: Measuring the Volume on the Suction Side

Measuring the Volume on the Discharge Side (Fig. 5.2)

Prior to the measurement:

- Fill and vent suction and discharge lines.
- Operate the pump for a short time
- Adjust the stroke length to 6,53 mm or 81,6 % as calculated in example 1.

Measurement

- Close the shutoff valve (4).
- Adjust the pressure sustaining valve (3) to the operating pressure.
- Read the quantity delivered by 100 strokes.

$$\text{measured volume} = V_{100 \text{ strokes}} (\text{cm}^3)$$

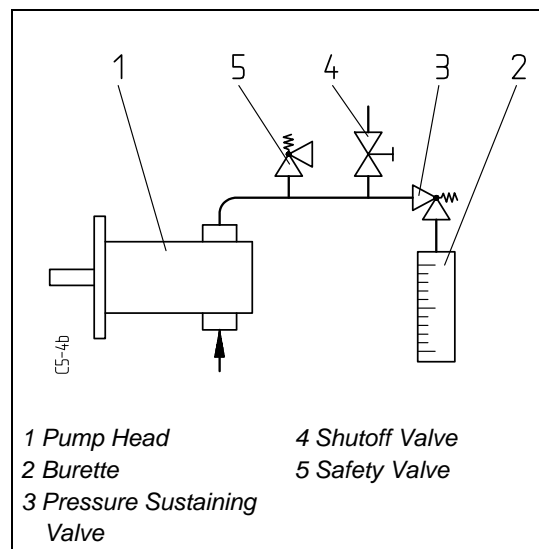

Fig. 5.2: Measuring the Volume on the Discharge Side

Determining the Actual Stroke Frequency

The actual stroke frequency is needed for the calculation of the actual capacity:

- Count the actual number of strokes per minute.

Actual capacity

With the volume $V_{100 \text{ strokes}}$ (Fig. 5.1 or 5.2) and the actual stroke frequency, the actual capacity can be calculated. $V_{100 \text{ strokes}}$ is assumed to be 2150 cm³, stroke frequency 150 strokes/min:

$$\text{actual capacity} = V_{100\text{strokes}} \times \frac{\text{actual stroke frequency} \times 60}{100 \times 1000} \text{ (l/h)}$$

$$\text{actual capacity} = 2150 \times \frac{150 \times 60}{100 \times 1000} \text{ (l/h)}$$

$$\text{actual capacity} = \underline{\underline{193,5 \text{ l/h}}}$$

Correction of the stroke length under operating conditions

With the actual capacity (see above) and the stroke length the corrected stroke length adjustment can be calculated:

$$\text{stroke length corr.} = \text{stroke length} \times \frac{\text{required capacity}}{\text{actual capacity}}$$

$$\text{stroke length corr.} = 6,53 \text{ mm} \times \frac{200}{193,5} = \underline{\underline{6,75 \text{ mm}}}$$

or

$$\text{stroke length corr.} = 81,6 \% \times \frac{200}{193,5} = \underline{\underline{84,3 \%}}$$

5.4.1 Flow Rate Curve

Another way of determining the corresponding stroke length for the required capacity is to use a flow rate curve. Due to the linear pressure metering characteristics it is easy to plot the flow rate curve for your specific pump:

- Calculate the correct stroke length for a required capacity, following the procedure described under 5.4. Repeat this for one further required capacity.

The values in *Table 5.1*, chosen as an example, are based on a max. stroke length of 8 mm and an operating pressure of 10 bar.

required capacity (l/h)	20	100
corr. stroke length in mm :	3	8
or in % :	37,5	100

Table 5.1: Example

- Plot the values onto a graph showing the corrected stroke length on the x-axis against the capacity on the y-axis.

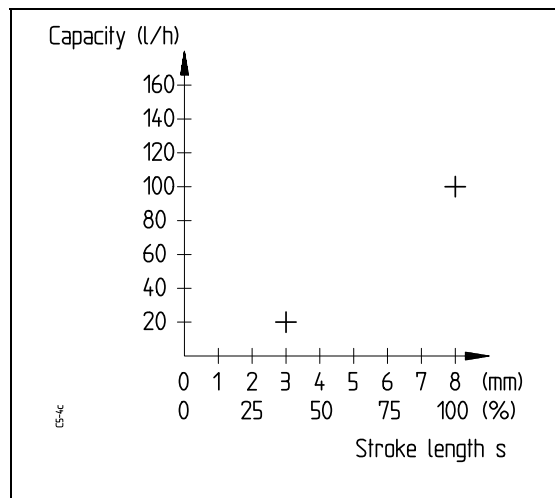

- Draw a line through the two points. The line does not meet the origin. A line meeting the origin would correspond to the optimal theoretical capacity not taking into account any operating conditions.

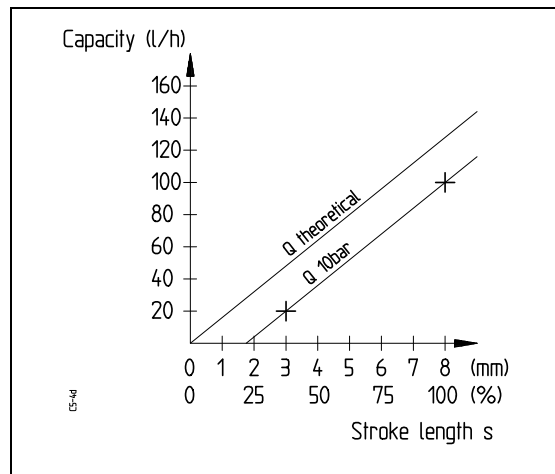

The flow rate curve is only valid as long as the operating conditions (e.g. operating pressure and medium used) stay the same!

6 Maintenance, Inspection, Cleaning

General

The completion of regular, complete and properly performed maintenance, inspection and cleaning tasks by technically competent, trained and qualified personnel guarantees trouble-free operation of the pump, increases the product quality and prevents any unplanned disruption of production operations.

**CAUTION!**

Improper maintenance of the pump can result in personal and property damage.

Let all maintenance, inspection and cleaning tasks be carried out by technically competent, trained or qualified personnel only.

Always carry out all maintenance, inspection and cleaning tasks on the pump only with the pump in properly protected, safe condition.

**CAUTION!**

Before performing any maintenance, inspection and cleaning tasks, all connections of the pump to sources of energy must be disconnected first.

In particular, separate the connections to the source of the electrical connection and / or compressed air.

Make sure that all auxiliary systems, drive units and extra equipment systems (piping, pipeworks) of the pump to be maintained/repared are switched off and depressurized.

Following the termination of the maintenance, inspection and cleaning tasks, all external objects such as tools, cleaning agents, cleaning rags, etc. must be removed from the pump area.

Following the maintenance, inspection and cleaning tasks, check whether all protective devices have been re-installed and are fully operational again.

In addition to the maintenance, inspection and cleaning tasks, inspections during the production process are also required. (See Table 6.1 to 6.2)

Drive Motor

Since the drive motor is not a SPX PROCESS EQUIPMENT product, please refer to the drive manufacturer's manual for proper drive lubrication and frequency.

Gear Unit

The following *Table 6.1* includes information regarding checks and maintenance.

What	When <i>h = hours of operation</i>	Who	Reference (section)
Oil level Check	weekly	Operator	5.1.
Surface temperature of the gear unit casing (Oil temperature) Check	weekly	Operator	5.1.
Oil change	half-yearly every 4.000 h	Expert	5.1.

Table 6.1: Maintenance Intervals Gear Unit

Pump Head

The following *Table 6.2* includes information regarding checks and maintenance.

What	When <i>h = hours of operation</i>	Who	Reference (section)
Plunger seals Check	monthly	Operator	3.3.
	yearly / every 8.000 h	Expert	
Flange connection of suction and discharge valve Check for leakage	monthly	Operator	3.3.
	in case of permeability / leakage *	Expert	
Diaphragm condition monitoring device Check	weekly	Operator	3.3.
	yearly every 8.000 h	Expert	

Table 6.2: Maintenance Intervals Pump Head

- * **Recommendation:** Whenever the diaphragm is changed, always replace the seals with original spare parts.

Cleaning



CAUTION!

Aggressive cleaning agents can cause skin irritations, rashes, burns and other forms of injury to health. Corrosion damage to metal parts is possible.

Whenever you pump dangerous (caustic, aggressive, toxic) media, note the fact that there can still be residue in the pump head. This residue can cause skin irritations, rash, burns and other forms of injury to health.



Avoid skin contact.

Wash your hands properly each time after coming into contact with these substances.

Wear protective equipment!

Clean the pump with chemically compatible cleaning agents only

Clean the gear/drive unit or the gear/drive unit parts with cold cleaning agents. (e.g. WBC 16)



CAUTION!

Risk of being burned due to hot surfaces of the gear /drive units.

Do not clean the gear/drive units until they have cooled off!

Clean the pump head or pump head parts with water only.



Protect the environment!

Handling and waste disposal of mineral oils and cleaning agents are subject to legal regulations.

Deliver old oil and cleaning waste materials to an authorized waste collection center.

7 Trouble Shooting

Problem	Possible Causes	Remedy
No Flow	<ul style="list-style-type: none"> <li data-bbox="527 346 852 388">• No voltage at the motor: <li data-bbox="527 451 738 493">• Motor broken: <li data-bbox="527 556 771 598">• Coupling broken: <li data-bbox="527 661 706 703">• No product: <li data-bbox="527 766 950 808">• Suction or discharge line shut off <li data-bbox="527 871 885 913">• Filter or pipe work clogged: <li data-bbox="527 976 950 1039">• Valves of pump head incorrectly fitted: <li data-bbox="527 1081 933 1123">• Pump valves damaged or dirty: <li data-bbox="527 1186 966 1228">• Gas or air in the product chamber: <li data-bbox="527 1291 901 1333">• Discharge pressure too high: <li data-bbox="527 1459 803 1501">• Suction lift too high: <li data-bbox="527 1606 998 1648">• Stroke length adjustment on "0" mm: 	<p data-bbox="1031 346 1307 388">Check fuses and leads</p> <p data-bbox="1031 451 1323 493">Repair or replace motor</p> <p data-bbox="1031 556 1453 619">Replace the coupling and eliminate the cause of the overload</p> <p data-bbox="1031 661 1242 703">Fill suction vessel</p> <p data-bbox="1031 766 1323 808">Open the shut off valves</p> <p data-bbox="1031 871 1323 913">Clean filter or pipe work</p> <p data-bbox="1031 976 1421 1039">Fit the valves correctly (note the arrows!) (See section 3.4)</p> <p data-bbox="1031 1081 1388 1123">Clean or replace pump valves</p> <p data-bbox="1031 1186 1421 1228">Vent and/or fill product chamber</p> <p data-bbox="1031 1291 1453 1438">Check the adjustment of the safety valve, check discharge line for length and nominal width, carry out a calculation of the pipework (see section 4.2)</p> <p data-bbox="1031 1459 1469 1585">Reduce suction head and, if necessary, increase supply pressure or install a surge tank (see section 4.3.1)</p> <p data-bbox="1031 1606 1421 1669">Adjust stroke length (see section 3.2).</p>

Problem	Possible Causes	Remedy
<p>Flow rate too high</p> <p>Excessive Discharge</p>	<ul style="list-style-type: none"> • Suction pressure higher than discharge pressure: • Suction or discharge lines too long or nominal width too small: 	<p>Mount pressure sustaining valve (see section 4.3, fig. 4.5 and 4.6).</p> <p>Enlarge nominal width or install pulsation damper</p>
<p>Flow rate too small</p>	<ul style="list-style-type: none"> • Pump valves are dirty or damaged: • Safety valve is leaking: • Safety valve in operation because of excessive pressure loss in discharge line: • Gas or air in the product: • Cavitation: • Wrong stroke length: 	<p>Clean or replace the pump valves</p> <p>Clean safety valve; replace or rework damaged parts</p> <p>Enlarge nominal width or install pulsation damper</p> <p>Increase suction pressure; vent and/or fill product chamber</p> <p>Increase suction pressure; vent and/or fill product chamber</p> <p>Check and, if necessary, recalculate or adjust stroke length</p>
<p>Flow rate unsteady</p>	<ul style="list-style-type: none"> • Impurity of the flow medium: • Valve seat or valve ball damaged: • Varying supply pressure or viscosity: 	<p>Flush pipework; if necessary, install strainer</p> <p>Lap or replace valve</p> <p>Check operating conditions</p>

8 Transport, Intermediate Storage, Preservation

ProCam^{MD}

8.1.1 Transport

During the trial run performed by the factory, the gear/drive unit is filled with a type of oil that acts as a preservative.

The oil is drained prior to the shipping procedure. However, the internal parts of the gear/drive unit remain covered by a thin oil protection coating.

Take the necessary measures to ensure proper transport in order to prevent damage to the pump in packaged and/or unpackaged condition.



During transport and later during storage the pump must be protected against moisture, salt-water, rain, sand storms, and direct sunlight

Only use suitable transport equipment, such as elevating trucks, fork-lift trucks and/or lifting cranes in order to transport the pump.

Dimensions and weights of the pump or pump parts → *see shipping order.*

Preparations for Transport Procedure

- Upon delivery, check the packaging for any signs of damage. Complaints about external damage to the packaging must be reported to the respective transport company immediately.
- Remove the packaging.
- Undo and remove all fastening screws and fastening elements on the packaging elements.

Observe the following instructions **before** transporting the pumps:



WARNING!

Risk of injury due to falling load. Serious injury may result.

During the lifting or lowering operation, do not stand underneath the load.

Stay away from the danger zone.

During the transport operation, use a hoisting crane and fasten the lifting gear only at the eyelets provided for this purpose (ring screws).

Do not remove the tension from the suspending equipment until the pump has been securely fastened on the foundation.



Wear safety gloves and, whenever necessary, a safety helmet.



Do not use any steel cables or chains!

Make sure that the transport cables have been correctly fastened and that the load-carrying capacity is sufficient.

- Lift up the pump slowly above its center of gravity.
- During the transport procedure, make sure that the pump remains in horizontal position and that it cannot slip out of the transport suspending equipment.
- Place the pump down slowly at the installation location. Make sure that the pump doesn't tip over.
- Line up the pump in its final position.
- Remove the transport cables and other auxiliary devices.
- Secure the pump firmly on the provided installation location.

8.1.2 Intermediate Storage

1. Storage in dry and well ventilated rooms

A storage period of up to 2 years is possible without any special precautionary measures.

2. Storage in rooms with high levels of air moisture

The pump must be sealed air-tight in plastic foil and be protected against condensation water by means of a suitable quantity of silica gel. Then a storage period of up to 2 years is possible.

3. Storage Outdoors

In addition to the measures mentioned in Item 2, a form of protection against precipitation, sandstorms and direct sunlight must be provided.

8.1.3 Preservation

Preservation of installed pumps

Fill up the pump with oil of the recommended quality in the specified quantity
(See section 5.1).

If the start of operation is delayed, the metering pump must be switched on for approx. 1 hour every month with a stroke length of "0" mm in order to wet all the exposed locations in the gear/drive unit with oil again..

Change the oil once a year.

After extended storage, an oil change is required prior to start-up of the pump. Afterwards, the specified oil changes must be carried out (see section 6).

9 Data, Drawings and Parts Lists

9.1 Pump Data – Maximum Capacity

Model No.	Max Pressure (psig)	Flowrate (GPH) @ _SPM				Max Str. Length	Approx. Weight Lbs
		64	94	127	188		
MD15S, MS15A, MD15P, MD15K	300 150	1.8	2.7	3.6	5.4	3mm	40 37
MD50S, MS50A, MD50P, MD50K	150 150	6.0	9.0	12.0	18.0	3mm	40 37
MD200S, MS200A, MD200P, MD200K	175 150	27.0	40.0	54.0	80.0	8mm	65 64

Table 9.1: Max. Capacity for ProCam MD

9.2 Material of Construction

Model / Type	MD15S MD50S	MD15A MD50A	MD15P MD50P	MD15K MD50K
Component				
Gearbox	Cast Iron	Cast Iron	Cast Iron	Cast Iron
End Cover & Conn.	316SS	Alloy 20	PVC	PVDF
Diaphragm	PTFE	PTFE	PTFE	PTFE
Disc	316SS	Alloy 20	PVC	PVDF
Valve Housing	316SS	Alloy 20	PVC	PVDF
Valve Seat	316SS	Alloy 20	PVC	PVDF
Valve Ball	316SS	Ceramic	Glass	Glass
Gaskets / O-rings*	316SS	Alloy 20	EPDM*	EPDM*

* Gaskets and O-rings available in FPM (optional)

Table 9.2a: Materials of Construction for MD15 and MD50

Model / Type	MD200S	MD200A	MD200P	MD200K
Component				
Gearbox	Cast Iron	Cast Iron	Cast Iron	Cast Iron
End Cover & Conn.	316SS	Alloy 20	PVC	PVDF
Diaphragm	PTFE	PTFE	PTFE	PTFE
Disc	316SS	Alloy 20	PVC	PVDF
Valve Housing	316SS	Alloy 20	PVC	PVDF
Valve Seat	316SS	Alloy 20	PVC	PVDF
Valve Ball	316SS	Ceramic	Ceramic	Ceramic
O-rings*	FD10	PTFE	EPDM*	EPDM*

* O-rings available in FPM (optional)

Table 9.2b: Materials of Construction for MD200

9.3 Drawings and Parts List

On the following pages you will find the drawings and parts lists of your pump. Confirm your pump model number(s) (e.g. MD15S) by checking the nameplate on each individual pump. The model number and material of construction are used to identify the correct part list for your pump.

If you need to order parts, select the position number of the part on the corresponding drawings, and identify the part number of the items you require.

Line	Qty	Description	Drawing- No.	Material	Part Number	Assembly Group
Z1	1	Pump Yoke, Spacer, D15	CV - 122	GGG 40	202049	Yoke D015
Z2	1	Tappet	CV - 22	1.4034	303381	
Z3	1	Spring	CV - 140	VD	190238	
Z4	1	Slot ring, 14 x 22 x 5,7		AU	369608	
Z5	1	Retaining Ring, 24 x 1,2	DIN 472	ST	101758	
Z6	2	Screw, M 6 x 40	DIN 912	8.8	180045	
Z7	1	O-ring, 45 x 2		NBR	152175	
Z8	1	Cap		PE	170209	
Z10	2	Screening		PE	303453	
G1	1	Housing	CV - 3	GG 20	229702	
G2	1	Shaft	CV - 126	C 45	251043	
G3	1	Worm Shaft 28/1 *	CV - 85	C 45	224057	
G4	1	Worm Wheel 28/1 *	CV - 86	2.106	223021	
G3	1	Worm Shaft 19/1 **	CV - 24	C 45	224054	
G4	1	Worm Wheel 19/1 **	CV - 19	2.106	223002	
G5	1	Bearing NUP 304			120150	
G6	1	Parallel Key, A 3 x 3 x 10	DIN 6885	ST 50-1K	100708	
G7	3	Bearing 6201	DIN 625		120040	
G8	1	Retaining ring, 32 x 1,2	DIN 472	Spr. Stl	101614	
G9	1	Retaining ring, 20 x 1,2	DIN 471	Spr. Stl	101604	
G10	1	Screw, Bolt G 3/8 - B2	CV - 73	Kunstst.	078557	
G11	1	Parallel Key, A 5 x 5 x 12	DIN 6885	ST 50-1K	100709	
G12	1	Screw, Bolt G 1/8"	DIN 908	A4	100097	
G13	1	Seal Ring, C 10 x 14	DIN 7603	FD12	150227	
G14	2	Shim, 22 x 32 x 0,1	DIN 988	ST	101518	
G15	1	Shim, 22 x 32 x 0,3	DIN 988	ST	101529	
G16	1	Retaining ring, 17 x 1	DIN 471	Spr. Stl	101704	
G17	1	Bearing 6301	DIN 625		120070	
G18	1	Washer, Disc EPL 30		Spr. Stl	101647	
X1	1	Cover	CV - 8	GG 20	229705	Cover Assy G1
X2	1	O-ring 66 x 2		NBR	152178	
X3	2	Screw, Bolt M6 x 16	ISO 4017	8.8	100230	

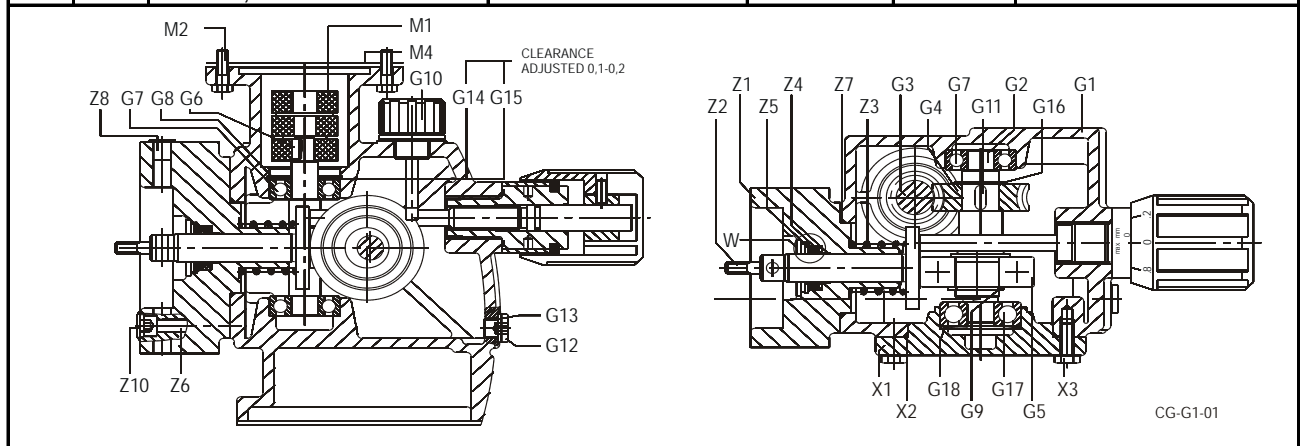

Producer Bran+Luebbe Delavan, WI	Description Gearbox G1 / MD15 - Master Part List	Drawing-No. CG-G1-01	Ident-No.
--	--	--------------------------------	-----------

Recommended Spares are indicated in **BOLD PRINT**.

*** The worm shaft and worm wheel (items G3 & G4) must be matched together with the same reduction ratio (28:1 or 19:1). Your reduction ratio is stamped on the outside cover of your gearbox housing (position X1).

Line	Qty	Description	Drawing- No.	Material	Part Number	Assembly Group
Z1	1	Pump Yoke, Spacer, D50	CV - 7	GGG 40	202040	Yoke D050
Z2	1	Tappet	CV - 22	1.4034	303381	
Z3	1	Spring	CV - 27	VD	190225	
Z4	1	Slot ring, 14 x 22 x 5,7		AU	369608	
Z5	1	Retaining Ring, 24 x 1,2	DIN 472	ST	101758	
Z6	2	Screw, M 6 x 40	DIN 912	8.8	180045	
Z7	1	O-ring, 45 x 2		NBR	152175	
Z8	1	Cap		PE	170209	
Z10	2	Screening		PE	303453	
G1	1	Housing	CV - 3	GG 20	229702	
G2	1	Shaft	CV - 126	C 45	251043	
G3	1	Worm Shaft 28/1 *	CV - 85	C 45	224057	
G4	1	Worm Wheel 28/1 *	CV - 86	2.106	223021	
G3	1	Worm Shaft 19/1 **	CV - 24	C 45	224054	
G4	1	Worm Wheel 19/1 **	CV - 19	2.106	223002	
G5	1	Bearing NUP 304			120150	
G6	1	Parallel Key, A 3 x 3 x 10	DIN 6885	ST 50-1K	100708	
G7	3	Bearing 6201	DIN 625		120040	
G8	1	Retaining ring, 32 x 1,2	DIN 472	Spr. Stl	101614	
G9	1	Retaining ring, 20 x 1,2	DIN 471	Spr. Stl	101604	
G10	1	Screw, Bolt G 3/8 - B2	CV - 73	Kunstst.	078557	
G11	1	Parallel Key, A 5 x 5 x 12	DIN 6885	ST 50-1K	100709	
G12	1	Screw, Bolt G 1/8"	DIN 908	A4	100097	
G13	1	Seal Ring, C 10 x 14	DIN 7603	FD12	150227	
G14	2	Shim, 22 x 32 x 0,1	DIN 988	ST	101518	
G15	1	Shim, 22 x 32 x 0,3	DIN 988	ST	101529	
G16	1	Retaining ring, 17 x 1	DIN 471	Spr. Stl	101704	
G17	1	Bearing 6301	DIN 625		120070	
G18	1	Washer, Disc EPL 30		Spr. Stl	101647	
X1	1	Cover	CV - 8	GG 20	229705	Cover Assy G1
X2	1	O-ring 66 x 2		NBR	152178	
X3	2	Screw, Bolt M6 x 16	ISO 4017	8.8	100230	

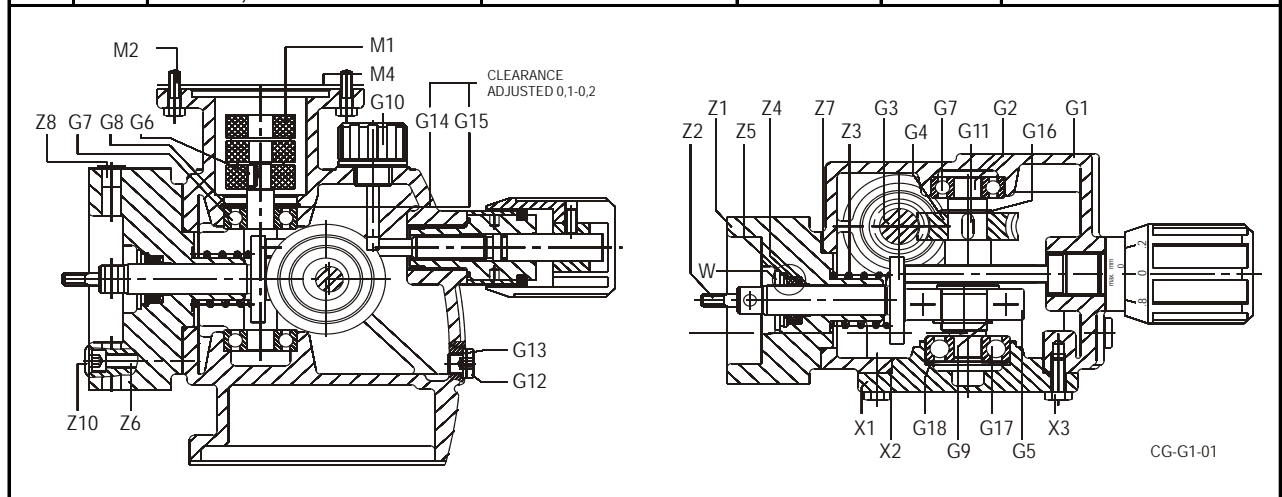

Producer	Description	Drawing-No.	Ident-No.
Bran+Luebbe Delavan, WI	Gearbox G1 / MD050 - Master Part List	CG-G1-01	

Recommended Spares are indicated in **BOLD PRINT**.

* ** The worm shaft and worm wheel (items G3 & G4) must be matched together with the same reduction ratio (28:1 or 19:1). Your reduction ratio is stamped on the outside cover of your gearbox housing (position X1).

Line	Qty	Description	Drawing- No.	Material	Part Number	Assembly Group
Z1	1	Pump Yoke, Spacer, D200	CV - 1	GG 20	202037	Yoke D200
Z2	1	Tappet	CV - 14	1.4112	303383	
Z3	1	Spring	CV - 151	VD	190254	
Z4	1	Slot ring, 20 x 28 x 5,7		AU	369609	
Z5	1	Retaining Ring, 31 x 1,2	DIN 472	Spr. Stl	101648	
Z6	4	Screw, M 6 x 40	DIN 912	8.8	100123	
Z7	1	O-ring, 54 x 2		NBR	152176	
Z8	1	Pin 5 x 8	ISO 8752	Spr. Stl	102001	
Z9	1	Cap		PE	170209	
G1	1	Housing	CV - 17	GG 25	229711	Gearbox, G2/D200
G2	1	Shaft	CV - 124	16MnCr5	251041	
G3	1	Worm Shaft 28/1 *	CV - 84	C 45	224056	
G4	1	Worm Wheel 28/1 *	CV - 83	2.1060	223020	
G3	1	Worm Shaft 38/2 **	CV - 21	C 45	224055	
G4	1	Worm Wheel 38/2 **	CV - 20	2.1060	223006	
G5	1	Ring	CV - 37	16MnCr5	229713	
G6	1	Parallel Key, A 5 x 5 x 18	DIN 6885	ST 50-1K	100531	
G7	2	Bearing 7202 BE	DIN 628		120071	
G8	1	Retaining ring, 35 x 1,5	DIN 472	Spr. Stl	101615	
G9	2	Retaining ring, 36 x 1,75	DIN 471	Spr. Stl	101649	
G10	1	Screw, Bolt G 3/8 - B2	CV - 73	Kunstst.	078557	
G11	1	Parallel Key, A 10 x 8 x 20	DIN 6885	ST 50-1K	100710	
G12	1	Screw, Bolt G 1/8"	DIN 908	A4	100097	
G13	1	Seal Ring, C 10 x 14	DIN 7603	FD12	150227	
G14	2	Shim, 25 x 35 x 0,1	DIN 988	ST	101546	
G15	1	Shim, 25 x 35 x 0,3	DIN 988	ST	101550	
X1	1	Cover	CV - 5	GG 25	229704	Cover Assy G2
X2	1	O-ring 80 x 2		NBR	152180	
X3	2	Screw, Bolt M6 x 12	ISO 4017	8.8	100229	

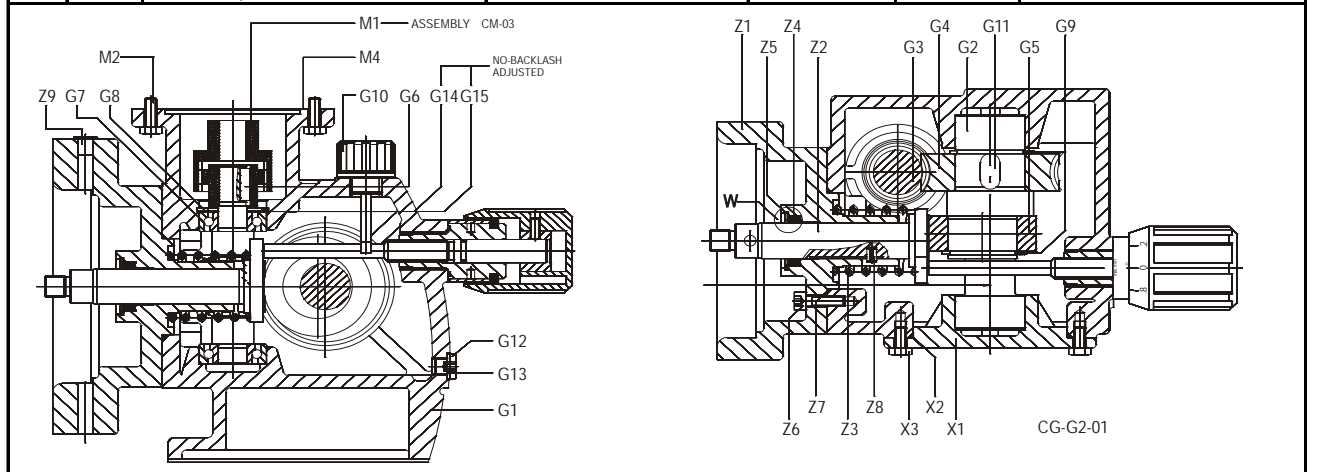

Producer	Description	Drawing-No.	Ident-No.
Bran+Luebbe Delavan, WI	Gearbox G2 / MD200 - Master Part List	CG-G2-01	

Recommended Spares are indicated in **BOLD PRINT**.

* ** The worm shaft and worm wheel (items G3 & G4) must be matched together with the same reduction ratio (28:1 or 19:1). Your reduction ratio is stamped on the outside cover of your gearbox housing (position X1).

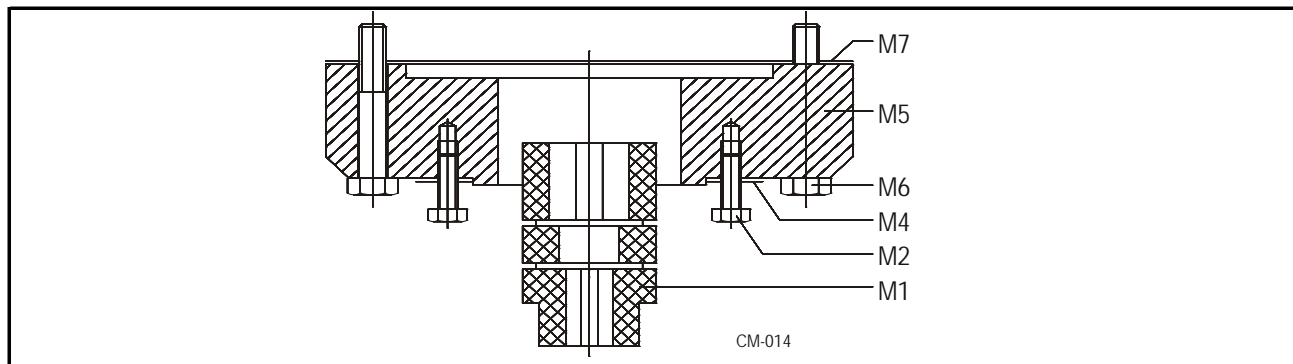

Line	Qty	Description	Drawing- No.	Material	Part Number	Assembly Group
M1	1	Coupling 5/8" x 9	ROTEX 14	AL-H	007250	G1 56C MAFA
M2	4	Screw, Bolt M5 x 16	ISO 4017	8.8 Zn	100225	
M4	1	Gasket, 0,25 thick	P - 20	FD 3	150068	
M5	1	Flange, 56C NEMA	CV - 149	C 45	007249	
M6	4	Screw, Bolt 3/8"-16 x 1-1/4"		8.8 Zn	006832	
M7	1	Gasket	CV - 152	FD 3	150494	
Producer		Description	Drawing-No.	Ident-No.		
Bran+Luebbe Delavan, WI		Motor Adapter Assembly for G1 to 56C	CM - 014	078386		

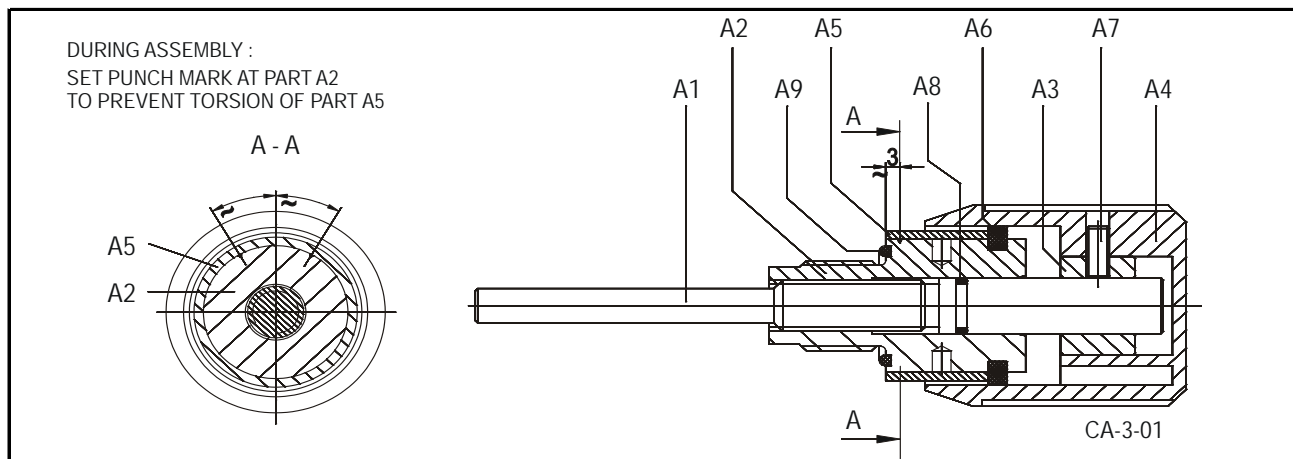

Line	Qty	Description	Drawing- No.	Material	Part Number	Assembly Group
A1	1	Spindle	CV - 25	C 45	201695	Stroke Adjustment
A2	1	Gland, Screw Connection	CV - 23	9SMS28K	303382	
A3	1	Bushing	CV - 29	9SMS28K	201696	
A4	1	Cap	CV - 60	PA	170233	
A5	1	Scale	CV - 68	PBT	155076	
A6	1	Ring	CV - 71	Zell-PUR	220101	
A7	1	Set Screw M5 x 12	DIN 916	A4	102159	
A8	1	O-ring, 10 x 2		NBR	152119	
A9	1	O-ring, 23 x 1,5		NBR	152174	
Producer		Description	Drawing-No.	Ident-No.		
Bran+Luebbe Delavan, WI		Stroke Adjustment Assy, Manual, 0- 3mm	CA - 3 - 01	440000		

Recommended Spares are indicated in **BOLD PRINT**.

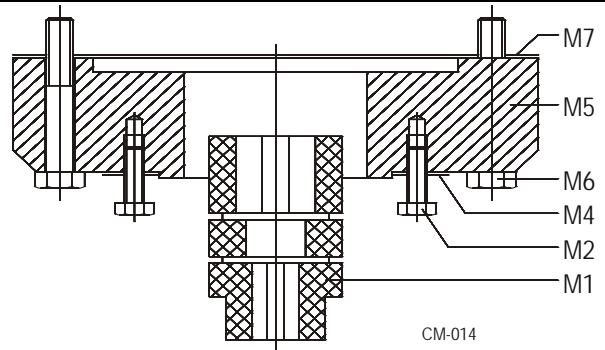

Line	Qty	Description	Drawing- No.	Material	Part Number	Assembly Group
M1	1	Coupling 5/8" x 14		St / Kunst	007271	G2 56C MAFA
M2	4	Screw, Bolt M6 x 16	ISO 4017	8.8	100230	
M4	1	Gasket	CV - 50	FD 3	150431	
M5	1	Flange, 56C NEMA	CV - 150	C 45	007251	
M6	4	Screw, Bolt 3/8"-16 x 1-1/4"		8.8 Zn	006832	
M7	1	Gasket	CV - 152	FD 3	150494	
Producer		Description	Drawing-No.	Ident-No.		
Bran+Luebbe Delavan, WI		Motor Adapter Assy for G2 - NEMA 56C	CM - 014	078385		

DURING ASSEMBLY :
SET PUNCH MARK AT PART A2
TO PREVENT TORSION OF PART A5

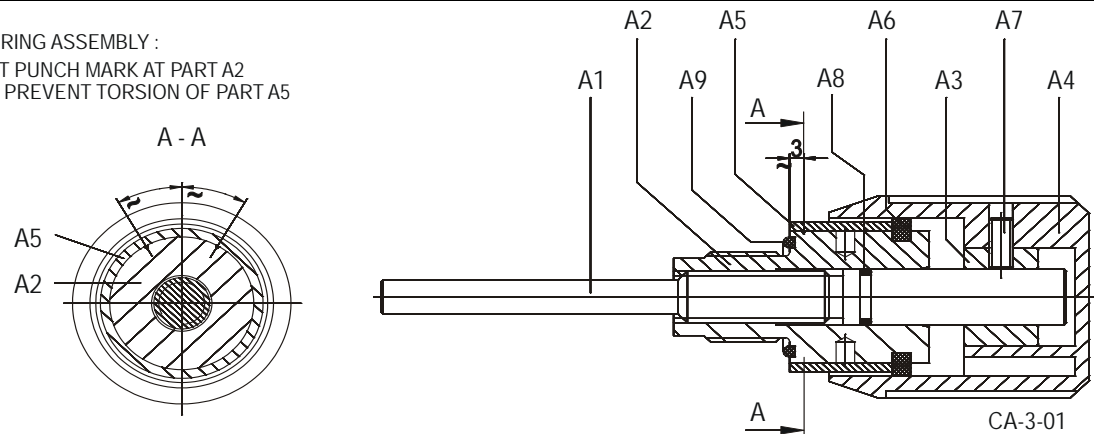

Line	Qty	Description	Drawing- No.	Material	Part Number	Assembly Group
A1	1	Spindle	CV - 25	C 45	201695	Stroke Adjustment
A2	1	Gland, Screw Connection	CV - 23	9SMn28K	303382	
A3	1	Bushing	CV - 29	9SMn28K	201696	
A4	1	Cap	CV - 60	PA	170233	
A5	1	Scale	CV - 69	PBT	155077	
A6	1	Ring	CV - 71	Zell-PUR	220101	
A7	1	Set Screw M5 x 12	DIN 916	A4	102159	
A8	1	O-ring, 10 x 2		NBR	152119	
A9	1	O-ring, 23 x 1,5		NBR	152174	
Producer		Description	Drawing-No.	Ident-No.		
Bran+Luebbe Delavan, WI		G2 Stroke Adjustment Assy, Manual, 0- 8mm	CA - 3 - 01	440001		

Recommended Spares are indicated in **BOLD PRINT**.

Line	Qty	Description	Drawing- No.	Material	Part Number
001	1	Housing	PV 18 - 20	1.4581	341495
002	1	Housing	PV 18 - 21	1.4581	341496
003	2	Ball, 7mm	DIN - 5401	1.4401	120501
004	1	Seat, valve	PV 18 - 22	1.4571	341497
005	2	Gasket		1.4571	150109
Producer		Description	Drawing-No.	Ident-No.	
Bran+Luebbe Delavan, WI		Dbi. Ball Valve, 316ss	PV18-06	540039	

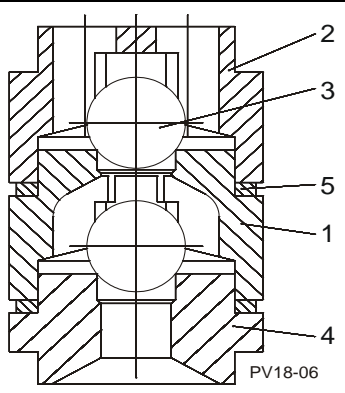

Line	Qty	Description	Drawing- No.	Material	Part Number
001	1	Housing	PV 18 - 37	Alloy 20	077612
002	1	Housing	PV 18 - 81	Alloy 20	077613
003	2	Ball, 7mm		AL2O3	129720
004	1	Seat, valve	PV 18 - 22	Alloy 20	077614
005	2	Gasket		Hast B	002637
Producer		Description	Drawing-No.	Ident-No.	
Bran+Luebbe Delavan, WI		Dbi. Ball Valve, Alloy 20 / Ceramic Ball	PV18-058	077611	

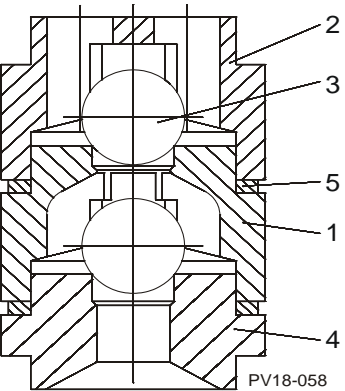

Line	Qty	Description	Drawing- No.	Material	Part Number
01	1	Housing	LD - 63	PVC	340766
02	1	Housing	LD - 64	PVC	340767
03	1	Valve Seat	LD - 62	PVC	340765
04	2	Ball, 7mm		Glas	120513
05	1	Gasket 14 x 17,5 x 1		FD11	150384
06	1	Direction Arrow	PV 18- 135		155035
Producer		Description	Drawing-No.	Ident-No.	
Bran+Luebbe Delavan, WI		Ball Valve, PVC/Ceramic	LD-020	540022	

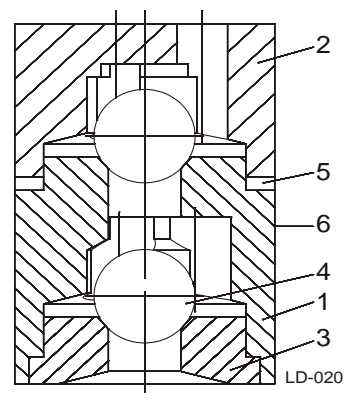

Line	Qty	Description	Drawing- No.	Material	Part Number
01	1	Housing	LD - 63	PVDF	075340
02	1	Housing	LD - 64	PVDF	075341
03	1	Valve Seat	LD - 62	PVDF	075342
04	2	Ball, 7mm		Glass	120513
05	1	Gasket, 14 x 17,5 x 1		EPDM	150384
06	1	Direction Arrow 20 x 10	PV18 - 135		155035
Producer		Description	Drawing-No.	Ident-No.	
Bran+Luebbe Delavan, WI		Ball Valve, PVDF/Ceramic	LD-020	075343	

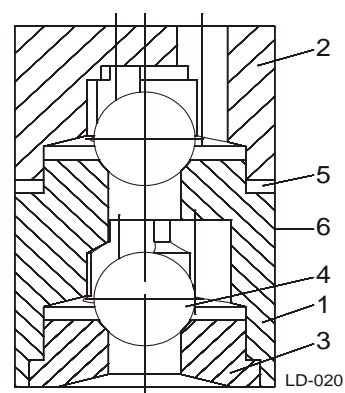

Line	Qty	Description	Drawing- No.	Material	Part Number
01	1	Housing	PV32 - 250	1.4581	341504
02	1	Valve Seat	PV32 - 247	1.4571	341507
03	1	Ball, 3/4"	ISO 3290 G28	1.4401	120517
04	1	Gasket, 23,5 x 28,5 x 1		FD10	150300
Producer		Description	Drawing-No.	Ident-No.	
Bran+Luebbe Delavan, WI		Dbl. Ball Valve, 316ss	PV32-0154	540031	

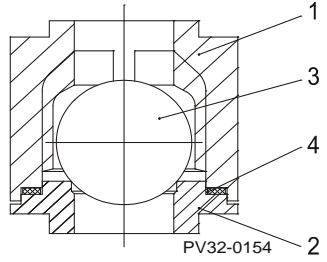

Line	Qty	Description	Drawing- No.	Material	Part Number
01	1	Housing	PV32 - 255	Alloy 20	077567
02	1	Valve Seat	PV32 - 247	Alloy 20	077569
03	1	Ball, 3/4"		AL2O3	129726
04	1	Gasket, 23,5 x 28,5 x 1		PTFE	150362
Producer		Description	Drawing-No.	Ident-No.	
Bran+Luebbe Delavan, WI		Dbl. Ball Valve, Alloy 20 / Ceramic Ball	PV32-0170	340018	

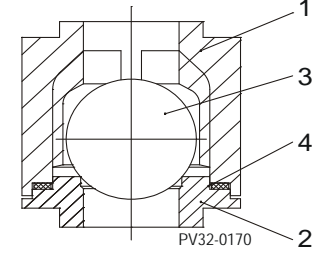

Line	Qty	Description	Drawing- No.	Material	Part Number
01	1	Housing	PV 34 - 2	PVC	340728
02	1	Valve Seat	PV 34 - 1	PVC	340729
03	1	Ball, 3/4"		Al2O3	129726
04	1	O-ring, 29 x 2,5		EPDM *	152160
05	1	Direction Arrow	PV 18- 135		155035
Producer		Description	Drawing-No.	Ident-No.	
Bran+Luebbe Delavan, WI		Ball Valve, PVC/Ceramic	PV34 - 01	540381	

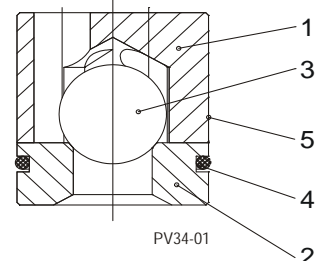

* Alternate O-ring material FPM available: replace o-ring with item # 078317

Line	Qty	Description	Drawing- No.	Material	Part Number
01	1	Housing	PV 34 - 2	PVDF	075134
02	1	Valve Seat	PV 34 - 1	PVDF	075135
03	1	Ball 3/4"		AL2O3	129726
04	1	O-ring, 29 x 2,5		EPDM*	152160
05	1	Direction Arrow 20 x 10	PV 18 - 135	Spint FO	155035
Producer		Description	Drawing-No.	Ident-No.	
Bran+Luebbe Delavan, WI		Ball Valve, PVDF/Ceramic	PV34 - 01	075136	

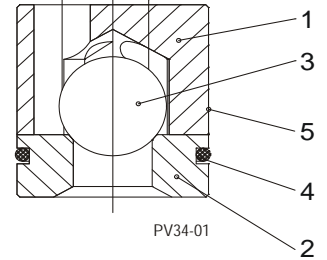

* Alternate O-ring material FPM available: replace o-ring with item # 078317

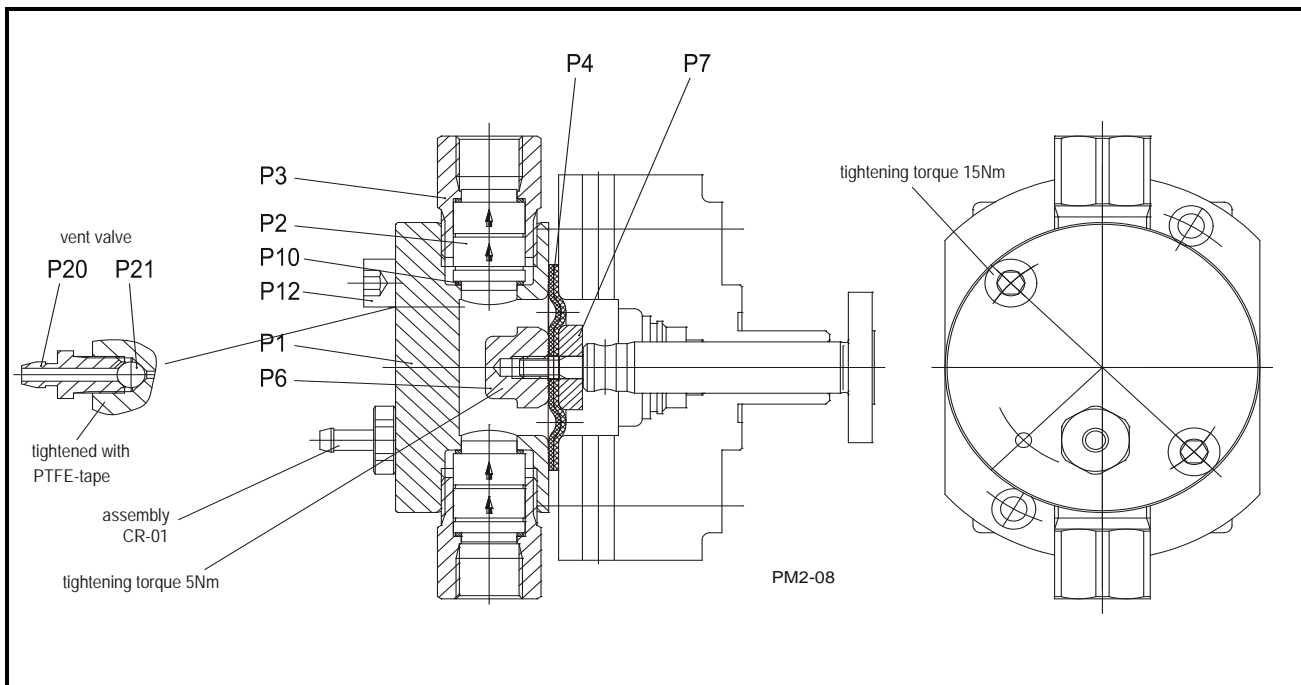

P1	1	Cover	PM 2 - 58	1.4571	320075	Assy Drawing PM2-08 Assy Number 1103263	MD15S = 316 ss
P2	2	Valve	PV 18 - 06	1.4581	540039		
P3	2	Connection, 3/8" NPTF	NI-1573	1.4571	326336		
P4	1	Diaphragm Assembly	PM 2 - 65	PTFE	320136		
P6	1	Plate	PM 2 - 61	1.4571	320076		
P7	1	Plate	PM 2 - 62	1.4571	320077		
P10	4	Gasket		1.4571	150109		
P12	2	SHCS, M 8 x 50	DIN 912	A2 - 70	100590		
P1	1	Cover	PM 2 - 58	Alloy 20	320124	Assy Drawing PM2-08 Assy Number 440125	MD15A = Alloy 20
P2	2	Valve	PV 18 - 058	Alloy 20	077611		
P3	2	Connection, 3/8" NPTF	NI-1573	Alloy 20	324109		
P4	1	Diaphragm Assembly	PM 2 - 65	PTFE	320136		
P6	1	Plate	PM 2 - 61	Alloy 20	320122		
P7	1	Plate	PM 2 - 62	1.4571	320077		
P10	4	Gasket 14 x 17 x 1		Alloy 20	150529		
P12	2	SHCS, M 8 x 50	DIN 912	A2 - 70	100590		
01 B	1	Press. Gauge, -1...25bar	NG 50	1.4571	600605	Diaphr. Rupture Assy Drawing CR-01	
01 C	1	Press. Switch (optional)			707510		
01 C	1	Adapter for Press. Switch (optional)			707511		
Producer	Description		Drawing-No.	Ident-No.		Quantity	
Bran+Luebbe Delavan, WI	Pumphead, MD15 Liquid End (316ss / Alloy 20)		PM2-08	Ref. Assy Group		1	

Recommended Spares are indicated in **BOLD PRINT**.

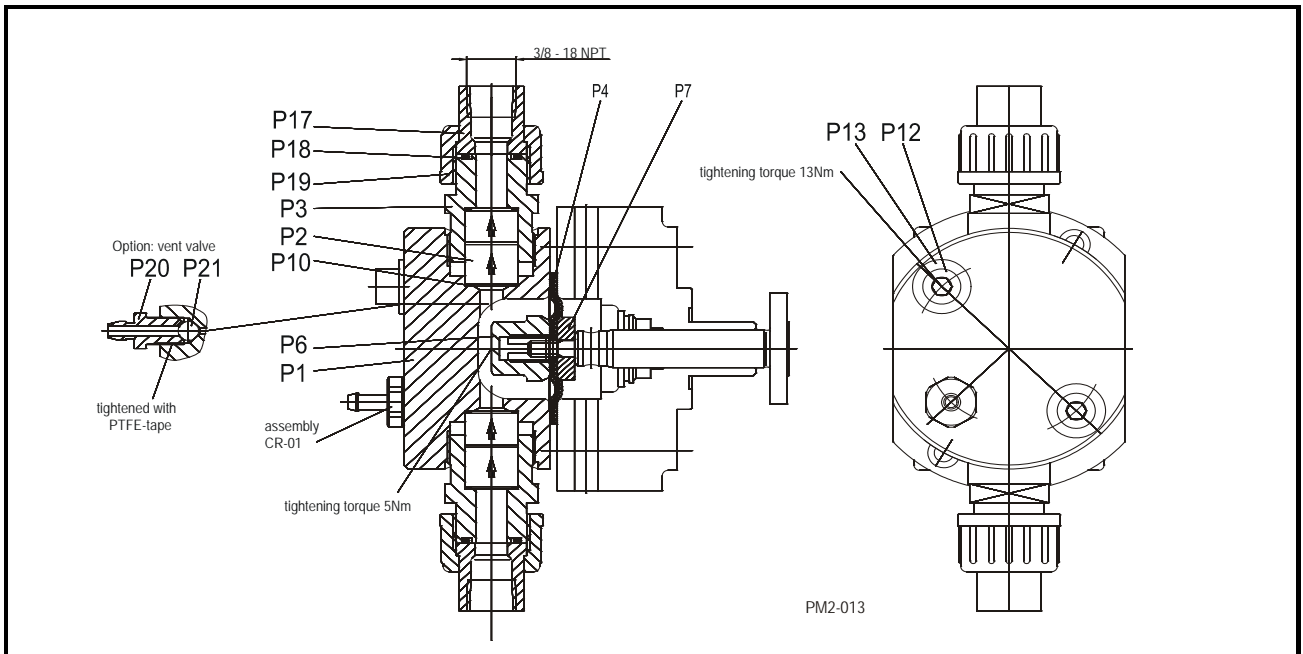

P1	1	Cover	PM 2 - 64	PVC	320082	Assy Drawing PM2-013 Assy Number 440129 * FPM Alt. = 077018 * FPM Alt. = 152043	MD15P = PVC		
P2	2	Valve	LD - 020	PVC	540022				
P3	2	Nipple, 10	LD - 45	PVC	326311				
P4	1	Diaphragm Assembly	PM 2 - 65	PTFE	320136				
P6	1	Plate	PM 2 - 63	PVC	320081				
P7	1	Plate	PM 2 - 62	1.4571	320077				
P10	4	Gasket, 14 x 17,5 x 1		EPDM*	150384				
P12	2	SHCS, M 8 x 65	DIN 912	A2 - 70	100592				
P13	2	Washer, Disc 8,4 x 20 x 1,5		A 2	101645				
P17	2	Nipple, 3/8" NPTF	PM 2 - 55	PVC	320072				
P18	2	O-ring, 15,5 x 2,6		EPDM*	170160				
P19	2	Nut, D-16	GF 21.69.00	PVC	170155				
P1	1	Cover	PM 2 - 64	PVDF	078690			Assy Drawing PM2-013 Assy Number 440130 * FPM Alt. = 077018 * FPM Alt. = 152043	MD15K = PVDF
P2	2	Valve	LD - 020	PVDF	075343				
P3	2	Nipple, 10	LD - 45	PVDF	075344				
P4	1	Diaphragm Assembly	PM 2 - 65	PTFE	320136				
P6	1	Plate	PM 2 - 63	PVDF	078697				
P7	1	Plate	PM 2 - 62	1.4571	320077				
P10	4	Gasket, 14 x 17,5 x 1		EPDM*	150384				
P12	2	SHCS, M 8 x 65	DIN 912	A2 - 70	100592				
P13	2	Washer, Disc 8,4 x 20 x 1,5		A 2	101645				
P17	2	Nipple, 3/8" NPTF	PM 2 - 55	PVDF	091974				
P18	2	O-ring, 15,5 x 2,6		EPDM*	170160				
P19	2	Nut, D-16	GF 35.69.04	PVDF	078707				
01 B	1	Press. Gauge, -1...25bar	NG 50	1.4571	600605	Diaphr. Rupture Assy Drawing CR-01			
01 C	1	Press. Switch (optional)			707510				
01 C	1	Adapter for Press. Switch (optional)			707511				
Producer	Description		Drawing-No.	Ident-No.	Quantity				
Bran+Luebbe Delavan, WI	Pumphead, MD15 Liquid End (PVC & PVDF)		PM2-013	Ref. Assy Group	1				

Recommended Spares are indicated in **BOLD PRINT**.

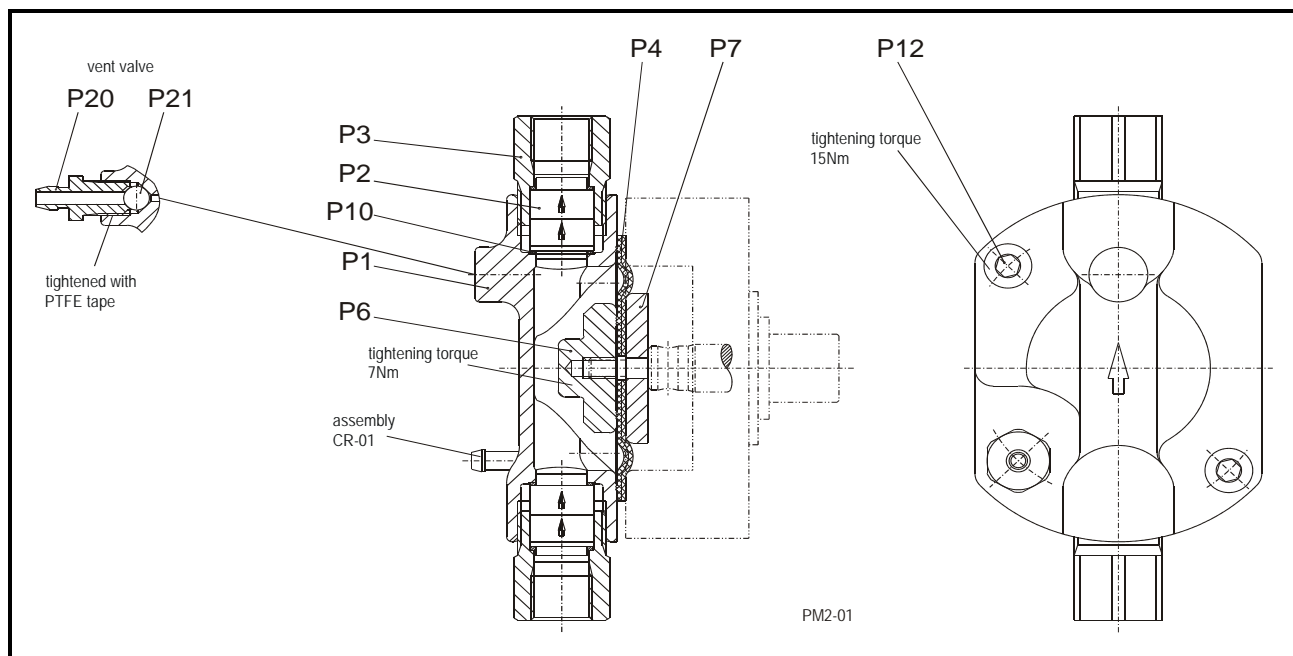

Line	Qty	Description	Drawing- No.	Material	Part Number	Assembly Group	
P1	1	Cover	PM 2 - 1	1.4571	320002	Assy Drawing PM2-01	MD50S = 316 ss
P2	2	Valve	PV 18 - 06	1.4581	540039		
P3	2	Connection, 3/8" NPTF	NI-1573	1.4571	326336		
P4	1	Diaphragm Assembly	PM 2 - 66	PTFE	320137	Assy Number 1103264	
P6	1	Plate	PM 2 - 19	1.4571	320003		
P7	1	Plate	PM 2 - 20	1.4571	320004		
P10	4	Gasket		1.4571	150109		
P12	2	SHCS, M 8 x 25	DIN 912	A4 - 70	100133		
P1	1	Cover	PM 2 - 87 A	Alloy 20	320125	Assy Drawing PM2-01	MD50A = Alloy 20
P2	2	Valve	PV 18 - 058	Alloy 20	077611		
P3	2	Connection, 3/8" NPTF	NI-1573	Alloy 20	324109		
P4	1	Diaphragm Assembly	PM 2 - 66	PTFE	320137	Assy Number 440126	
P6	1	Plate	PM 2 - 19	Alloy 20	320123		
P7	1	Plate	PM 2 - 20	1.4571	320004		
P10	4	Gasket, 14 x 17 x 1		Alloy 20	150529		
P12	2	SHCS, M 8 x 50	DIN 912	A2 - 70	100590		
01 B	1	Press. Gauge, -1...25bar	NG 50	1.4571	600605	Diaphr. Rupture Assy Drawing CR-01	
01 C	1	Press. Switch (optional)			707510		
01 C	1	Adapter for Press. Switch (optional)			707511		
Producer	Description		Drawing-No.	Ident-No.		Quantity	
Bran+Luebbe Delavan, WI	Pumphead, MD50 Liquid End (316ss & Alloy 20)		PM2-01	Ref. Assy Group			

Recommended Spares are indicated in **BOLD PRINT**.

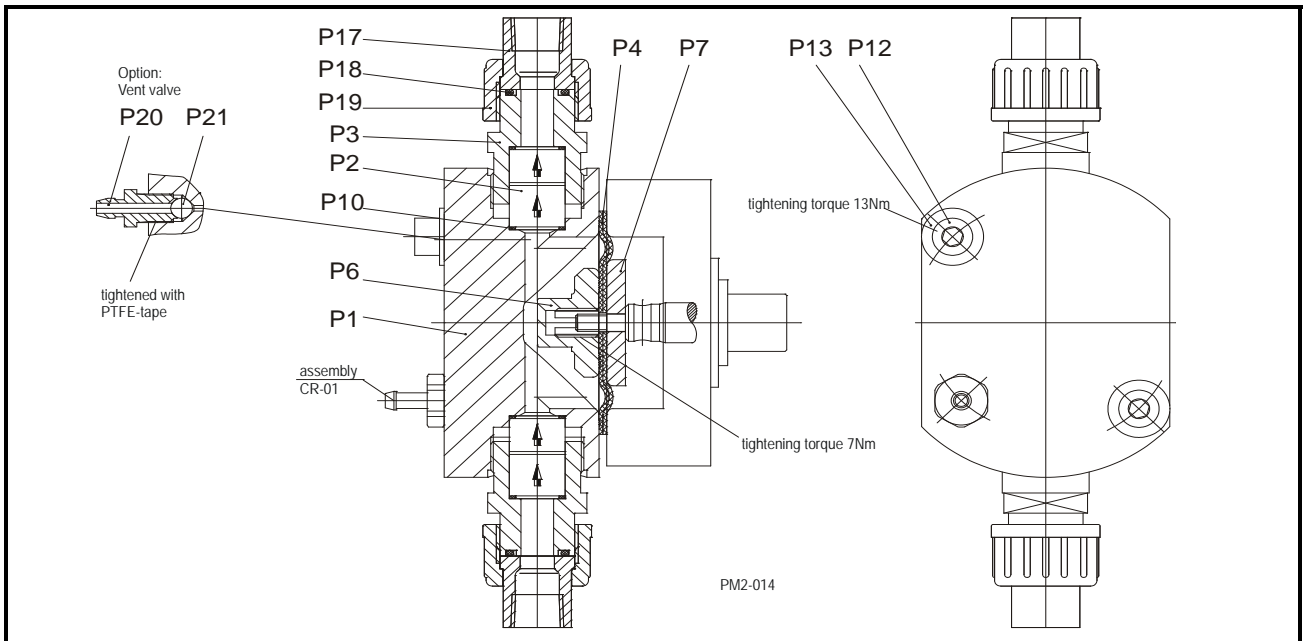

Line	Qty	Description	Drawing- No.	Material	Part Number	Assembly Group			
P1	1	Cover	PM 2 - 4	PVC	320019	Assy Drawing PM2-014 Assy Number 440131 * FPM Alt. = 077018 * FPM Alt. = 152043	MD50P = PVC		
P2	2	Valve	LD - 020	PVC	540022				
P3	2	Nipple, 10	LD - 45	PVC	326311				
P4	1	Diaphragm Assembly	PM 2 - 66 A	PTFE	320137				
P6	1	Plate	PM 2 - 27	PVC	320032				
P7	1	Plate	PM 2 - 20	1.4571	320004				
P10	4	Gasket, 14 x 17,5 x 1		EPDM*	150384				
P12	2	SHCS, M 8 x 65	DIN 912	A2 - 70	100592				
P13	2	Washer, Disc 8,4 x 20 x 1,5		A 2	101645				
P17	2	Nipple, 3/8" NPTF	PM 2 - 55	PVC	320072				
P18	2	O-ring, 15,5 x 2,6		EPDM*	170160				
P19	2	Nut, D-16	GF 21.69.00	PVC	170155				
P1	1	Cover	PM 2 - 4	PVDF	078698			Assy Drawing PM2-014 Assy Number 440132 * FPM Alt. = 077018 * FPM Alt. = 152043	MD50K = PVDF
P2	2	Valve	LD - 020	PVDF	075343				
P3	2	Nipple, 10	LD - 45	PVDF	075344				
P4	1	Diaphragm Assembly	PM 2 - 66	PTFE	320137				
P6	1	Plate	PM 2 - 27	PVDF	078699				
P7	1	Plate	PM 2 - 20	1.4571	320004				
P10	4	Gasket, 14 x 17,5 x 1		EPDM*	150384				
P12	2	SHCS, M 8 x 65	DIN 912	A2 - 70	100592				
P13	2	Washer, Disc 8,4 x 20 x 1,5		A 2	101645				
P17	2	Nipple, 3/8" NPTF	PM 2 - 55	PVDF	091974				
P18	2	O-ring, 15,5 x 2,6		EPDM*	170160				
P19	2	Nut, D-16	GF 35.69.04	PVDF	078707				
01 B	1	Press. Gauge, -1...25bar	NG 50	1.4571	600605	Diaphr. Rupture Assy			
01 C	1	Press. Switch (optional)			707510		Drawing CR-01		
01 C	1	Adapter for Press. Switch (optional)			707511				
Producer	Description		Drawing-No.	Ident-No.	Quantity				
Bran+Luebbe Delavan, WI	Pumphead, MD50 Liquid End (PVC & PVDF)		PM2-014	Ref. Assy Group					

Recommended Spares are indicated in **BOLD PRINT**.

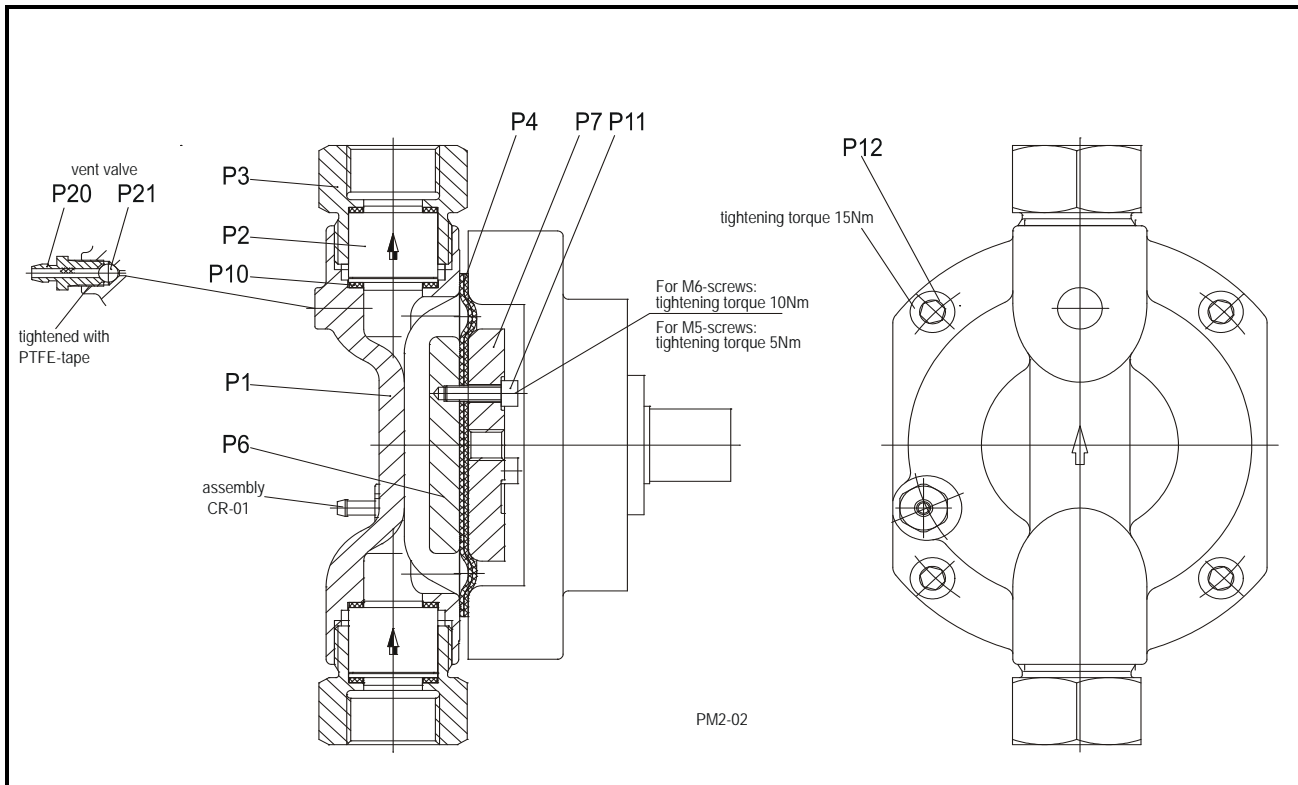

Line	Qty	Description	Drawing- No.	Material	Part Number	Assembly Group	
P1	1	Cover	PM 2 - 2	1.4581	320005	Assy Drawing PM2-02	MD200S = 316 ss
P2	2	Valve	PV32 - 0154	1.4581	540031		
P3	2	Connection, 1/2" NPTF	PM 2 - 53	1.4571	078103	Assy Number 440127	
P4	1	Diaphragm Assembly	PM 2 - 67 A	PTFE	320139		
P6	1	Plate	PM 2 - 23	1.4571	320010		
P7	1	Plate	PM 2 - 24	1.4034	320009		
P10	4	Gasket		FD10	150120		
P11	3	SHCS, M 5 x 16	DIN 912	8.8 Zn	100720		
P12	4	SHCS, M 10 x 60	DIN 912	A2	100161		
01 B	1	Press. Gauge, -1...25bar	NG 50	1.4571	600605	Diaphr. Rupture Assy Drawing CR-01	
01 C	1	Press. Switch (optional)			707510		
01 C	1	Adapter for Press. Switch (optional)			707511		
Producer	Description		Drawing-No.	Ident-No.		Quantity	
Bran+Luebbe Delavan, WI	Pumphead, MD200 Liquid End (316ss)		PM2-02	440127			

Recommended Spares are indicated in **BOLD PRINT**.

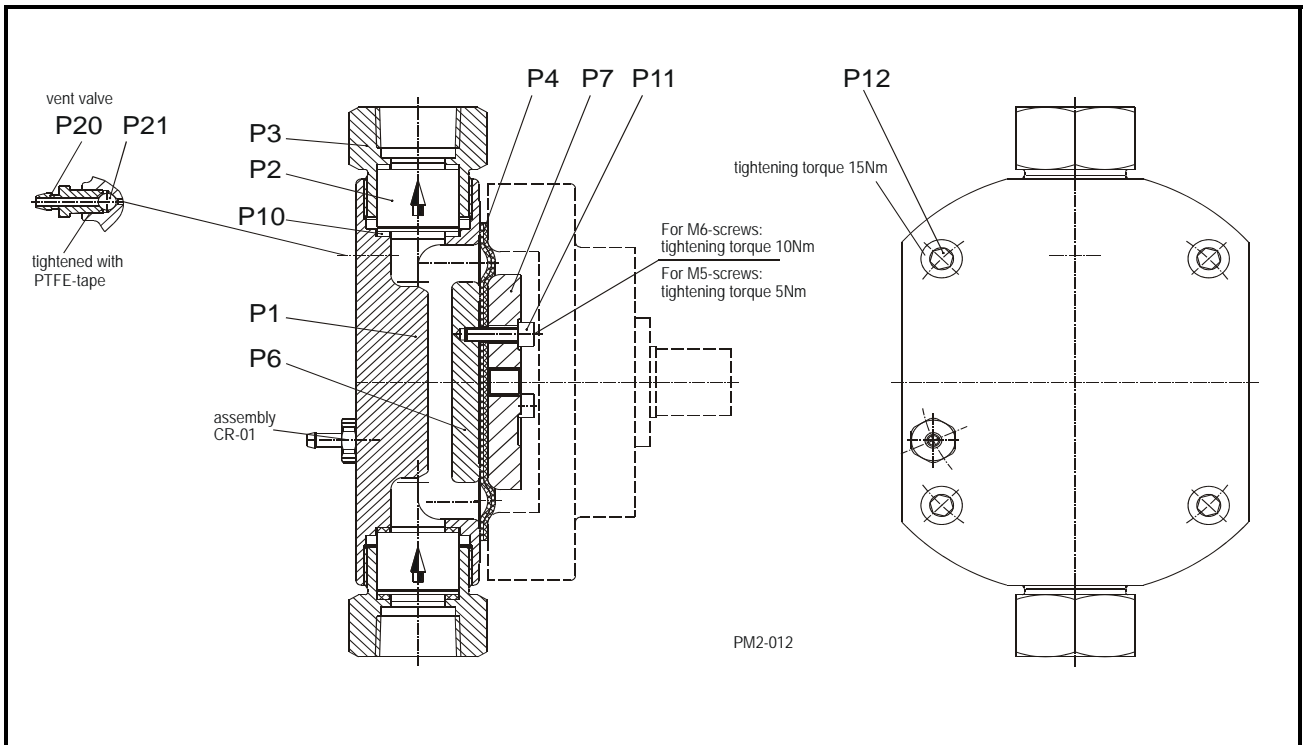

Line	Qty	Description	Drawing- No.	Material	Part Number	Assembly Group	
P1	1	Cover	PM 2 - 73	Alloy 20	320127	Assy Drawing PM2-012	MD200A = Alloy 20
P2	2	Valve	PV32 - 0170	Alloy 20	340018		
P3	2	Connection, 1/2" NPTF	PM 2 - 53	Alloy 20	320126		
P4	1	Diaphragm Assembly	PM 2 - 67 A	PTFE	320139	Assy Number 440128	
P6	1	Plate	PM 2 - 23	Alloy 20	320128		
P7	1	Plate	PM 2 - 24	1.4034	320009		
P10	4	Gasket		FD4	150141		
P11	3	SHCS, M 5 x 16	DIN 912	8.8 Zn	100720		
P12	4	SHCS, M 10 x 60	DIN 912	A2-70	065429		
01 B	1	Press. Gauge, -1...25bar	NG 50	1.4571	600605	Diaphr. Rupture Assy Drawing CR-01	
01 C	1	Press. Switch (optional)			707510		
01 C	1	Adapter for Press. Switch (optional)			707511		
Producer	Description		Drawing-No.	Ident-No.	Quantity		
Bran+Luebbe Delavan, WI	Pumphead, MD200 Liquid End (Alloy 20)		PM2-012	440128			

Recommended Spares are indicated in **BOLD PRINT**.

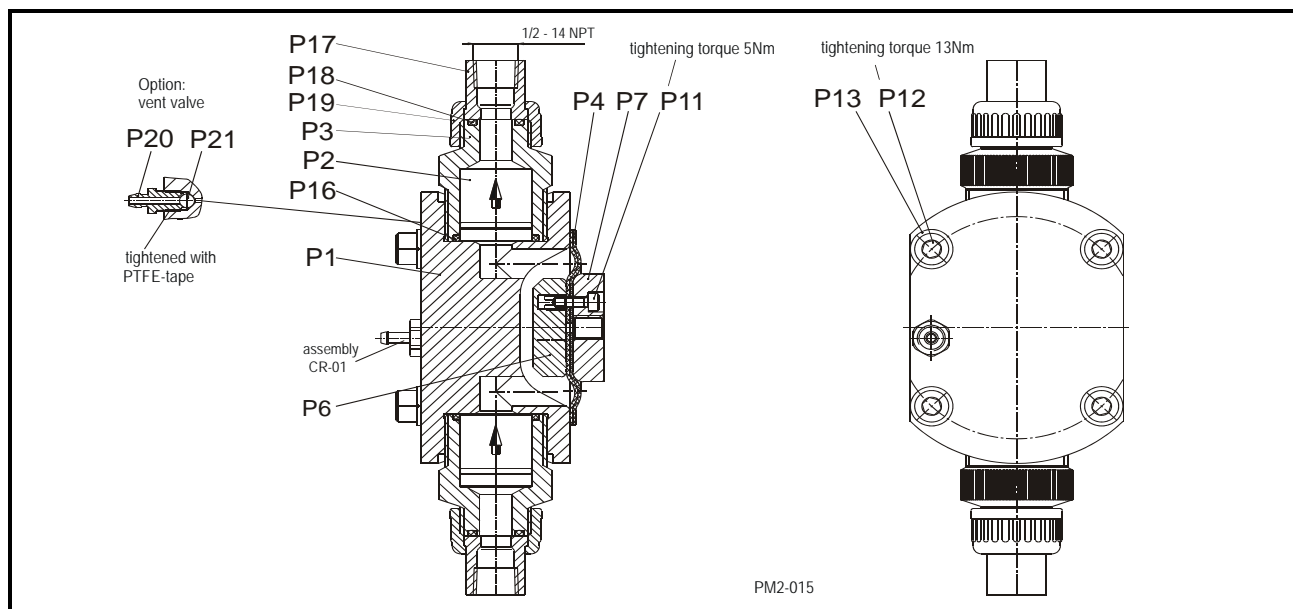

Line	Qty	Description	Drawing- No.	Material	Part Number	Assembly Group		
P1	1	Cover	PM 2 - 6	PVC	320021	Assy Drawing PM2-015	MD200P = PVC	
P2	2	Valve	PV 34 - 01	PVC	540381			
P3	2	Connection Cover	PN - 1782	PVC	303342			
P4	1	Diaphragm Assembly	PM 2 - 67 A	PTFE	320139	Assy Number 440134		
P6	1	Plate	PM 2 - 50	PVC	320134			
P7	1	Plate	PM 2 - 24	1.4034	320009			
P10	3	SHCS, M5 x 16	DIN 912	8.8 Zn	100720			
P12	4	SHCS, M 10 x 85	DIN 912	A2 - 70	100752			
P13	4	Washer, Disc 10,5	DIN 125	A 2	101506			
P16	2	O-ring, 34 x 3,5		EPDM*	152162	* FPM Alt. = 083617		
P17	2	Nipple, 1/2" NPT	PM 2 - 56	PVC	320073			
P18	2	O-ring, 20,2 x 3,5		EPDM*	170161	* FPM Alt. = 152040		
P19	2	Nut, D-20	GF 21.69.00	PVC	170190			
P1	1	Cover	PM 2 - 6	PVDF	078408	Assy Drawing PM2-015		MD200K = PVDF
P2	2	Valve	PV 34 - 01	PVDF	075136			
P3	2	Connection Cover	PN - 1782	PVDF	075139			
P4	1	Diaphragm Assembly	PM 2 - 67 A	PTFE	320139	Assy Number 440133		
P6	1	Plate	PM 2 - 50	PVDF	078409			
P7	1	Plate	PM 2 - 24	1.4034	320009			
P11	3	SHCS, M5 x 16	DIN 912	8.8 Zn	100720			
P12	4	SHCS, M 10 x 85	DIN 912	A2 - 70	100752			
P13	4	Washer, Disc 10,5	DIN 125	A 2	101506			
P16	2	O-ring, 34 x 3,5		EPDM*	152162	* FPM Alt. = 083617		
P17	2	Nipple, 1/2" NPT	PM 2 - 56	PVDF	059695			
P18	2	O-ring, 20,2 x 3,5		EPDM*	170161	* FPM Alt. = 152040		
P19	2	Nut, D-20	GF 35.69.04	PVDF	075137			
01 B	1	Press. Gauge, -1...25bar	NG 50	1.4571	600605	Diaphr. Rupture Assy Drawing CR-01		
01 C	1	Press. Switch (optional)			707510			
01 C	1	Adapter for Press. Switch (optional)			707511			
Producer	Description		Drawing-No.	Ident-No.		Quantity		
Bran+Luebbe Delavan, WI	Pumphead, MD200 Liquid End (PVC & PVDF)		PM2-015	Ref. Assy Group				

Recommended Spares are indicated in **BOLD PRINT**.

10 Drive Lubrication and Frequency

Refer to the drive manufacturer's manual for proper drive lubrication and frequency.

motralec

4 rue Lavoisier . ZA Lavoisier . 95223 HERBLAY CEDEX

Tel. : 01.39.97.65.10 / Fax. : 01.39.97.68.48

Demande de prix / e-mail : service-commercial@motralec.com

www.motralec.com