

Cutter Pumps

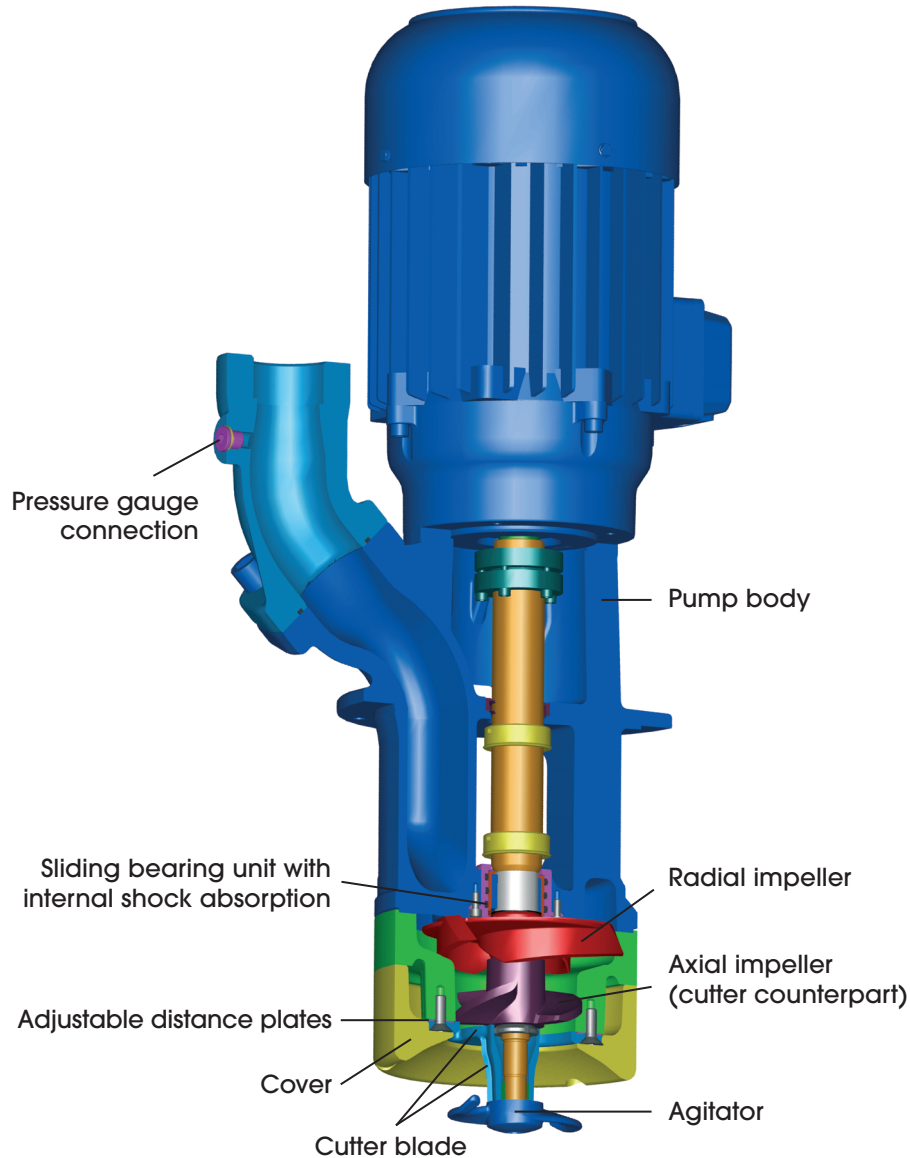

Cutter Pumps are capable of cutting and pumping aluminium chips
Chip to coolant ratios upto 1.5% by weight
Oversized motor to transfer additional cutting forces
Dry running capability
Adjustable gap between both cutting blades for preventive maintenance
Maintenance free and shock absorbing bearing bushing

Installation advice

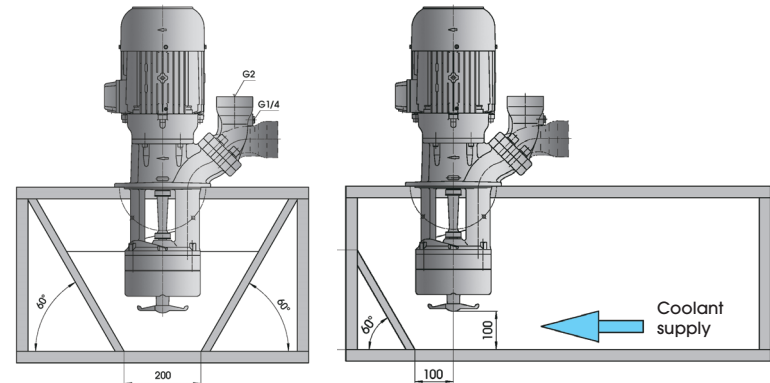

www.motralec.com
service-commercial@motralec.com