

**motralec**

4 rue Lavoisier . ZA Lavoisier . 95223 HERBLAY CEDEX  
Tel. : 01.39.97.65.10 / Fax. : 01.39.97.68.48  
Demande de prix / e-mail : service-commercial@motralec.com  
[www.motralec.com](http://www.motralec.com)

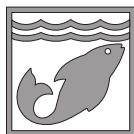

**ELECTRIC SUBMERSIBLE PUMPS**  
**ELECTROPOMPES IMMERGEES**  
**ELETTROPOMPE SOMMERSE**

**E4 - 6**

Poles  
Pôles  
Poli 2 50 Hz

**Desert**

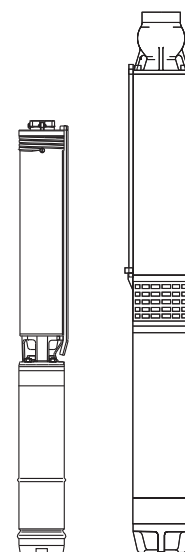

**caprari**

pumping power



	Page - Page - Pagina
Key to codes; <i>Explication des désignations</i> ; <b>Esemplificazione delle sigle</b>	3
Pump construction and materials; <i>Construction de la pompe et matériels</i> ; <b>Costruzione pompa e materiali</b>	4
Motor construction and materials; <i>Construction du moteur et matériels</i> ; <b>Costruzione motore e materiali</b>	7
General notes about the wet end; <i>Remarques générales partie hydraulique</i> ; <b>Note generali parte idraulica</b>	10
Motor general remarks; <i>Notes générales moteur</i> ; <b>Note generali motore</b>	11
Performance ranges; <i>Champs de performances</i> ; <b>Campi di prestazioni</b>	12
Pumps operating data, dimensions and weights; <i>Caractéristiques de fonctionnement, dimensions et poids électropompes</i> ; <b>Caratteristiche di funzionamento, dimensioni e pesi elettropompe</b>	13
Friction losses; <i>Pertes de charge</i> ; <b>Perdite di carico</b>	39
Motor operating data, dimensions and weights; <i>Caractéristiques de fonctionnement, dimensions et poids moteurs</i> ; <b>Caratteristiche di funzionamento, dimensioni e pesi motori</b>	40
Dynamic momentum of the wet end; <i>Moment dynamique partie hydraulique</i> ; <b>Momento dinamico parte idraulica</b>	46
Dynamic momentum of the motor; <i>Moment dynamique moteur</i> ; <b>Momento dinamico motore</b>	47
Feeding cables; <i>Câbles d'alimentation</i> ; <b>Cavi di alimentazione</b>	48
Generator power; <i>Puissance du generateur</i> ; <b>Potenza del generatore</b>	58
Common electric formulae; <i>Formules d'usage commun</i> ; <b>Formule di uso comune</b>	59
Electrical tolerances; <i>Tolérances électriques</i> ; <b>Tolleranze elettriche</b>	60
Reactive power compensation; <i>Compensation de la puissance reactive</i> ; <b>Compensazione della potenza reattiva</b>	62
Accessories; <i>Accessoires</i> ; <b>Accessori</b>	63

1) Electric pump code: - Désignation de l'électropompe: - Sigla elettropompa:

Ex. - Ex. - Es.  
**E4XED 25/31 + MCK 43-8V**                      **E6XPD 52/3A + MAC65A-8V**  
**E4XPD 60/13 + MCK 455-8V**  
**E6XD 20/30 + MAC 65A - 8V**  
**E6XDB 40/60 + MAC650B-8V**

2) Examples of wet end identification codes - Identification du sigle des partie hydraulique - Esemplificazione sigle parti idrauliche

**E4XED 25-4/31-V:** E4X ED 25 -4 /31 -V  
**E4X** = Series - Série - Serie \_\_\_\_\_  
**ED** = Desert - Desert - Desert \_\_\_\_\_  
**25** = Identification wet number - Numero identification hydraulique - Numero di identificazione idraulica \_\_\_\_\_  
**-4** = Coupling flange motor 4" - Bride d'accouplement moteur 4" - Flangia accoppiamento motore 4" \_\_\_\_\_  
**/31** = Number of stages - Nombre d'étages- Numero degli stadi \_\_\_\_\_  
**-V** = Unit used at 50 Hz - Ensemble avec utilization a 50 Hz - Gruppo con impiego a 50 Hz \_\_\_\_\_

**E6XD 20-6/30-V:** E 6 XD 20 -6 /30 -V  
**E** = Series - Série - Serie \_\_\_\_\_  
**6** = DN in inch - DN en pouces - DN in pollici \_\_\_\_\_  
**XD** = Desert - Desert - Desert \_\_\_\_\_  
**20** = Identification wet number - Numero identification hydraulique - Numero di identificazione idraulica \_\_\_\_\_  
**-6** = Coupling flange motor 6" - Bride d'accouplement moteur 6" - Flangia accoppiamento motore 6" \_\_\_\_\_  
**/30** = Number of stages - Nombre d'étages- Numero degli stadi \_\_\_\_\_  
**-V** = Unit used at 50 Hz - Ensemble avec utilization a 50 Hz - Gruppo con impiego a 50 Hz \_\_\_\_\_

**E6XDB 40-6/60-V:** E 6 XD B 40 -6 /60 -V  
**E** = Series - Série - Serie \_\_\_\_\_  
**6** = DN in inch - DN en pouces - DN in pollici \_\_\_\_\_  
**XD** = Desert - Desert - Desert \_\_\_\_\_  
**B** = Intermediate casing construction - Version avec support intermediaire - Versione con supporto intermedio \_\_\_\_\_  
**40** = Identification wet number - Numero identification hydraulique - Numero di identificazione idraulica \_\_\_\_\_  
**-6** = Coupling flange motor 6" - Bride d'accouplement moteur 6" - Flangia accoppiamento motore 6" \_\_\_\_\_  
**/60** = Number of stages - Nombre d'étages- Numero degli stadi \_\_\_\_\_  
**-V** = Unit used at 50 Hz - Ensemble avec utilization a 50 Hz - Gruppo con impiego a 50 Hz \_\_\_\_\_

**E4XPD 60-4/13-W:** E4X PD 60 -4 /13 -W  
**E4X** = Series - Série - Serie \_\_\_\_\_  
**PD** = Extra Performance Desert \_\_\_\_\_  
**60** = Identification wet number - Numero identification hydraulique - Numero di identificazione idraulica \_\_\_\_\_  
**-4** = Coupling flange motor 4" - Bride d'accouplement moteur 4" - Flangia accoppiamento motore 4" \_\_\_\_\_  
**/13** = Number of stages - Nombre d'étages- Numero degli stadi \_\_\_\_\_  
**-W** = Unit used at 50/60 Hz - Ensemble avec utilization a 50/60 Hz - Gruppo con impiego a 50/60 Hz \_\_\_\_\_

**E6XPD 52-6/3A-V:** E 6 XPD 52 -6 /3 A -V  
**E** = Series - Série - Serie \_\_\_\_\_  
**6** = DN in inch - DN en pouces - DN in pollici \_\_\_\_\_  
**XPD** = Extra Performance Desert \_\_\_\_\_  
**52** = Identification wet number - Numero identification hydraulique - Numero di identificazione idraulica \_\_\_\_\_  
**-6** = Coupling flange motor 6" - Bride d'accouplement moteur 6" - Flangia accoppiamento motore 6" \_\_\_\_\_  
**/3** = Number of stages - Nombre d'étages- Numero degli stadi \_\_\_\_\_  
**A** = Impeller trimming - Rognage roue - Riduzione girante \_\_\_\_\_  
**-V** = Unit used at 50 Hz - Ensemble avec utilization a 50 Hz - Gruppo con impiego a 50 Hz \_\_\_\_\_

3) Examples of submersible motor identification codes - Identification du sigle des moteurs immergés - Esemplificazione sigle motori sommersi

**MCK43 -8 :** MC K 4 3 -8  
**MC** = Submersible motor - Moteur immergé - Motore sommerso \_\_\_\_\_  
**K** = Axial thrust - Poussée axiale - Spinta assiale \_\_\_\_\_  
**4** = Nominal diameter in inches - Diamètre nominal en pouces- Diametro nominale in pollici \_\_\_\_\_  
**3** = Nominal power in CV - Puissance nominale en CV - Potenza nominale in CV \_\_\_\_\_  
**-8** = Constructional features of electric motor - Caractéristiques de fabrication moteur électrique - Caratteristiche costruttive motore elettrico \_\_\_\_\_

**MCR455 -8** MC R 4 55 -8  
**MC** = Submersible motor - Moteur immergé - Motore sommerso \_\_\_\_\_  
**R** = Axial thrust - Poussée axiale - Spinta assiale \_\_\_\_\_  
**4** = Nominal diameter in inches - Diamètre nominal en pouces- Diametro nominale in pollici \_\_\_\_\_  
**55** = Nominal power in CV - Puissance nominale en CV - Potenza nominale in CV \_\_\_\_\_  
**-8** = Constructional features of electric motor - Caractéristiques de fabrication moteur électrique - Caratteristiche costruttive motore elettrico \_\_\_\_\_

**MAC65/2A -8 :** MAC 6 5 /2 A -8  
**MAC** = Submersible motor - Moteur immergé - Motore sommerso \_\_\_\_\_  
**6** = Nominal diameter in inches - Diamètre nominal en pouces- Diametro nominale in pollici \_\_\_\_\_  
**5** = Nominal power in CV - Puissance nominale en CV - Potenza nominale in CV \_\_\_\_\_  
**/2** = Generational code - Code générationnel - Codice generazionale \_\_\_\_\_  
**A** = Hi Tech \_\_\_\_\_  
**-8** = Constructional features of electric motor - Caractéristiques de fabrication moteur électrique - Caratteristiche costruttive motore elettrico \_\_\_\_\_

**MAC650/2B -8 :** MAC 6 50 /2 B -8  
**MAC** = Submersible motor - Moteur immergé - Motore sommerso \_\_\_\_\_  
**6** = Nominal diameter in inches - Diamètre nominal en pouces- Diametro nominale in pollici \_\_\_\_\_  
**50** = Nominal power in CV - Puissance nominale en CV - Potenza nominale in CV \_\_\_\_\_  
**/2** = Generational code - Code générationnel - Codice generazionale \_\_\_\_\_  
**B** = Hi Tech Desert \_\_\_\_\_  
**-8** = Constructional features of electric motor - Caractéristiques de fabrication moteur électrique - Caratteristiche costruttive motore elettrico \_\_\_\_\_

# E4-6 E4XED E4XPD

Pump construction and materials  
Construction de la pompe et matériaux  
Costruzione pompa e materiali

E4XED

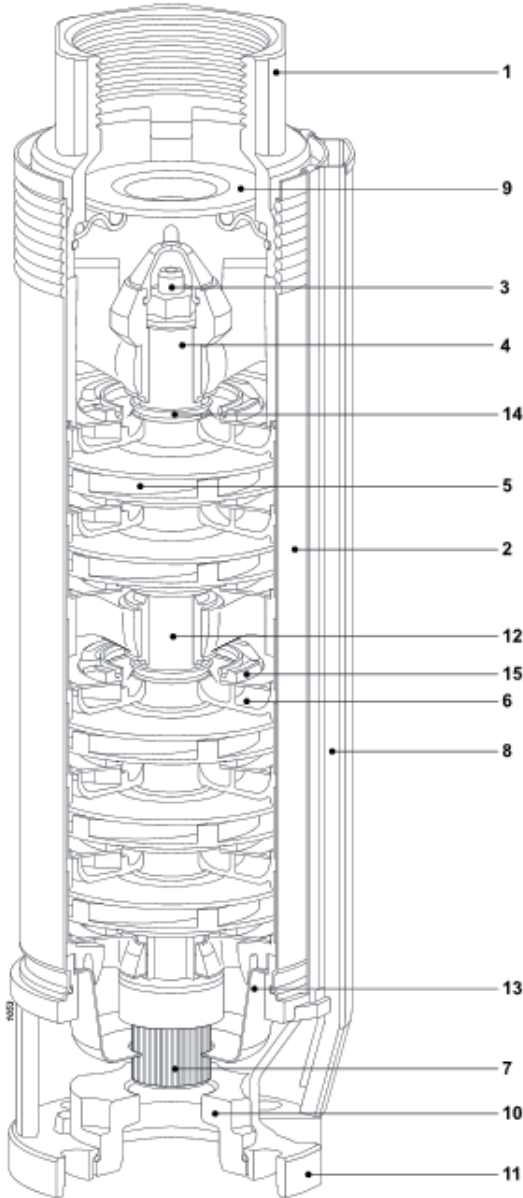

E4XPD

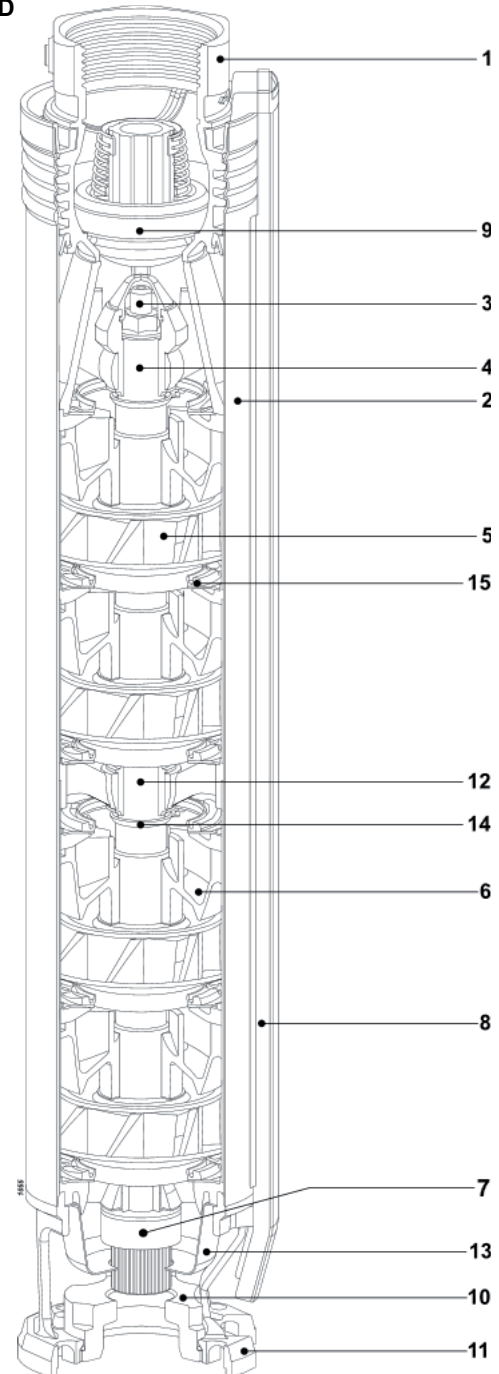

Pos.	Parts	Materials	Nomenclature	Matériaux	Nomenclatura	Materiale
1	Valve body	Stainless steel	Corps du clapet	Acier inox	Corpo valvola	Acciaio inox
2	Casing	Stainless steel	Chemise	Acier inox	Mantello	Acciaio inox
3	Shaft	Stainless steel	Arbre	Acier inox	Albero	Acciaio inox
4 (12)	Shaft sleeve	Aluminium oxide	Entretoise d'arbre	Alumine	Bussola albero	Allumina
5	Impeller	Technopolymer	Roue	Polymère technique	Girante	Tecnopolimero
6	Diffuser	Technopolymer	Diffuseur	Polymère technique	Diffusore	Tecnopolimero
7	Box coupling	Stainless steel	Accouplement a manchon	Acier inox	Manicotto di trasmissione	Acciaio inox
8	Cable guard	Stainless steel	Goutier protectif	Acier inox	Tegolo di protezione cavi	Acciaio inox
9	Conical valve	Stainless steel	Soupape du clapet	Acier inox	Clapet	Acciaio inox
9	Conical valve (E4XPD)	Technopolymer	Soupape du clapet (E4XPD)	Polymère technique	Clapet (E4XPD)	Tecnopolimero
10	Defender®	-	Defender®	-	Defender®	-
11	Suction cover	Stainless steel	Pièce d'aspiration	Acier inox	Supporto aspirazione	Acciaio inox
13	Strainer	Stainless steel	Crepine	Acier inox	Succheruola	Acciaio inox
14	Sand guard	Stainless steel	Para-sable	Acier inox	Parasabbia	Acciaio inox
15	Intermediate plate	Stainless steel/rubber	Disque intermediaire	Acier inox/caoutchouc	Disco intermedio	Acciaio inox/gomma

Bolts and nuts in stainless steel.

Visserie en acier inox

Bulloneria in acciaio inox

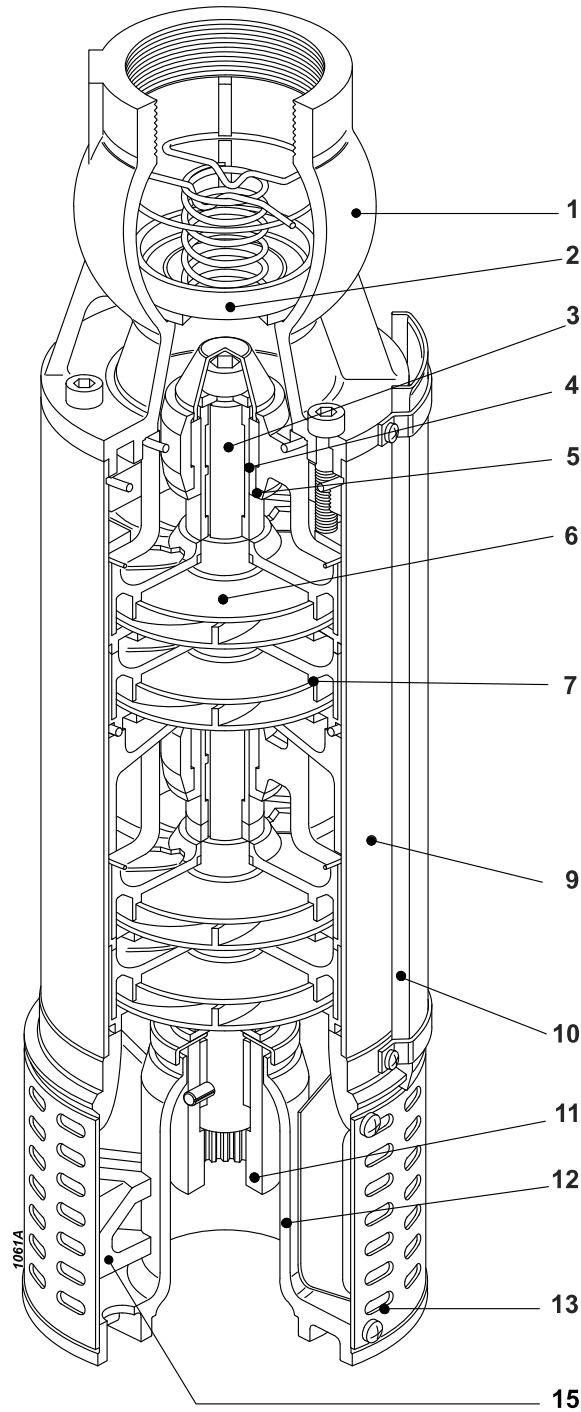

Pos.	Parts	Materials	Nomenclature	Matériaux	Nomenclatura	Materiale
1	Valve casing	Stainless steel	Corps du clapet	Acier inox	Corpo valvola	Acciaio inox
2	Conical valve	Stainless steel	Soupape du clapet	Acier inox	Clapet	Acciaio inox
3	Pump shaft	Stainless steel	Arbre de pompe	Acier inox	Albero	Acciaio inox
4	Shaft sleeve	Stainless steel	Entretoise d'arbre	Acier inox	Bussola albero	Acciaio inox
5	Pump shaft bearing bush	Rubber	Coussinet arbre pompe	Caoutchouc	Cuscinetto albero	Gomma
6	Impeller	Technopolymer	Roue	Polymère technique	Girante	Tecnopolimero
7	Diffuser	Technopolymer	Diffuseur	Polymère technique	Diffusore	Tecnopolimero
9	Stage casing	Stainless steel	Corps d'Etage	Acier inox	Mantello	Acciaio inox
10	Cable guard	Stainless steel	Gouttière de protection	Acier inox	Tegolo protezione cavi	Acciaio inox
11	Flange coupling	Stainless steel	Accouplement rigide	Acier inox	Giunto rigido	Acciaio inox
12	Suction cover	Stainless steel	Pièce d'aspiration	Acier inox	Supporto aspirazione	Acciaio inox
13	Strainer	Stainless steel	Crepine	Acier inox	Succheruola	Acciaio inox
15	Defender®	-	Defender®	-	Defender®	-

Bolts and nuts in stainless steel

Visserie en acier inox

Bulloneria in acciaio inox

# E4-6 E6XDB E6XPDB

Pump construction and materials  
Construction de la pompe et matériaux  
Costruzione pompa e materiali

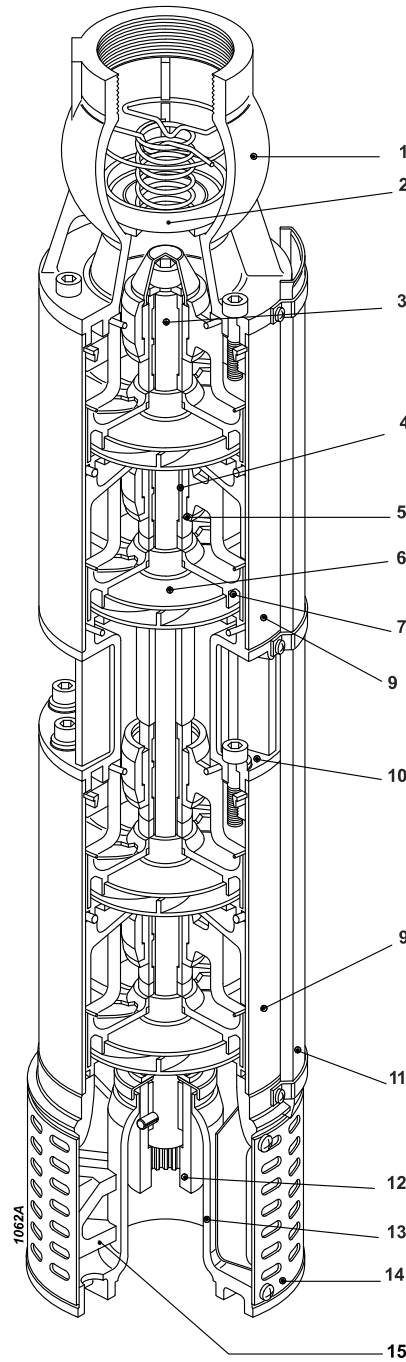

Pos.	Parts	Materials	Nomenclature	Matériaux	Nomenclatura	Materiale
1	Valve casing	Stainless steel	Corps du clapet	Acier inox	Corpo valvola	Acciaio inox
2	Conical valve	Stainless steel	Soupage du clapet	Acier inox	Clapet	Acciaio inox
3	Pump shaft	Stainless steel	Arbre de pompe	Acier inox	Albero	Acciaio inox
4	Shaft sleeve	Stainless steel	Entretoise d'arbre	Acier inox	Bussola albero	Acciaio inox
5	Pump shaft bearing bush	Rubber	Coussinet arbre pompe	Caoutchouc	Cuscinetto albero	Gomma
6	Impeller	Technopolymer	Roue	Polymère technique	Girante	Tecnopolimero
7	Diffuser	Technopolymer	Diffuseur	Polymère technique	Diffusore	Tecnopolimero
9	Stage casing	Stainless steel	Corps d'Etage	Acier inox	Mantello	Acciaio inox
10	Intermediate bearing	Stainless steel	Palier intermediaire	Acier inox	Supporto intermedio	Acciaio inox
11	Cable guard	Stainless steel	Gouttière de protection	Acier inox	Tegolo protezione cavi	Acciaio inox
12	Flange coupling	Stainless steel	Accouplement rigide	Acier inox	Giunto rigido	Acciaio inox
13	Suction cover	Stainless steel	Pièce d'aspiration	Acier inox	Supporto aspirazione	Acciaio inox
14	Strainer	Stainless steel	Crepine	Acier inox	Succheruola	Acciaio inox
15	Defender®	-	Defender®	-	Defender®	-

Bolts and nuts in stainless steel.

Visserie en acier inox

Bulloneria in acciaio inox

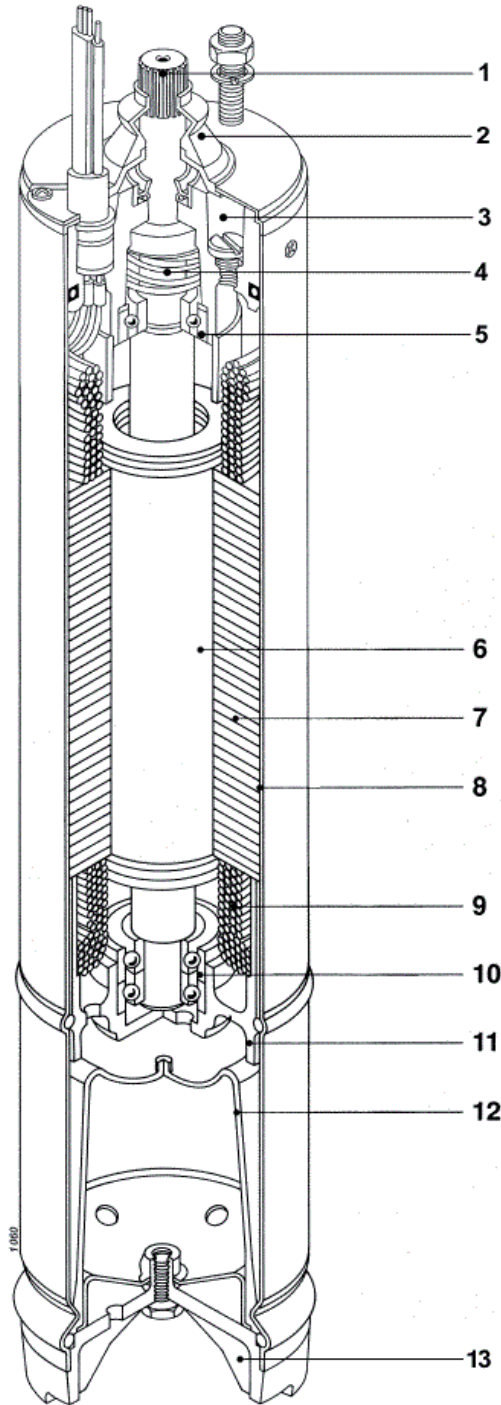

Pos.	Parts	Materials	Nomenclature	Matériaux	Nomenclatura	Materiale
1	Shaft	Stainless steel	Arbre	Acier inox	Albero	Acciaio inox
2	Sand guard	Rubber	Para-sable	Caoutchouc	Parasabbia	Gomma
3	Upper bracket	Cast iron	Support supérieur	Fonte grise	Supporto superiore	Ghisa grigia
4	Mechanical seal	Ceramic/graphite	Garniture mécanique	Céramique/graphite	Tenuta meccanica	Ceramica/grafite
5	Upper ball bearing	Steel	Roulement supérieur	Acier	Cuscinetto superiore	Acciaio
6	Rotor	Electrical steel	Rotor	Tôle magnétique	Rotore	Lamierino magnetico
7	Stator	Electrical steel	Stator	Tôle magnétique	Statore	Lamierino magnetico
8	Stator shell	Stainless steel	Chemise de stator	Acier inox	Camicia statore	Acciaio inox
9	Winding	Copper	Bobinage	Cuivre	Avvolgimento	Rame
10	Lower ball bearing	Steel	Roulement inférieur	Acier	Cuscinetto inferiore	Acciaio
11	Lower bracket	Aluminium	Support inférieur	Alluminium	Supporto inferiore	Alluminio
12	Diaphragm	Rubber	Membrane	Caoutchouc	Membrana	Gomma
13	Diaphragm cover	Stainless steel	Couvercle de membrane	Acier inox	Coperchio membrana	Acciaio inox
13	Diaphragm cover	Technopolymer	Couvercle de membrane	Tecnopolimero	Coperchio membrana	Tecnopolimero

Bolts and nuts in stainless steel.

Vissage en acier inox

Bulloneria in acciaio inox

# E4-6 MAC6-2A

Motor construction and materials  
Construction du moteur et matériaux  
Costruzione motore e materiali

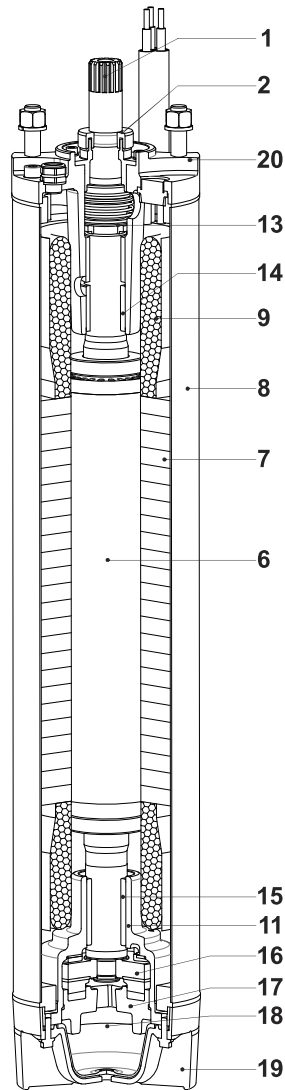

Pos.	Parts	Materials	Nomenclature	Matériaux	Nomenclatura	Materiale
1	Shaft	Stainless steel	Arbre	Acier inox	Albero	Acciaio inox
2	Sand guard	Rubber	para-sable	Caoutchouc	Parasabbia	Gomma
6	Rotor	Electrical steel	Rotor	Tôle magnétique	Rotore	Lamierino magnetico
7	Stator	Electrical steel	Stator	Tôle magnétique	Statore	Lamierino magnetico
8	Stator shell	Stainless steel	Chemise de stator	Acier inox	Camicia statore	Acciaio inox
9	Winding	HT wire	Bobinage	Fil HT	Avvolgimento	Filo HT
11	Lower bracket	Cast iron	Support inférieur	Fonte grise	Supporto inferiore	Ghisa grigia
13	Mechanical seal	Graphite/Aluminium	Garniture mécanique	Graphite/Alumine	Tenuta meccanica	Grafite/Allumina
14-15	Bearing bush	HT Composite	Coussinet	HT Composite	Bussola	Composito HT
16	Thrust-bearing	Stainless steel/ Synthetic compound	Butée	Acier inox/Composé synthétique	Reggispinta	Acciaio inox/ Composto sintetico
16	Thrust-bearing	Brass/Synthetic compound	Butée	Laiton/Composé synthétique	Reggispinta	Ottone/Composto sintetico
17	Thrust-bearing foot slip	Cast iron	Support butée	Fonte grise	Supporto reggispinta	Ghisa grigia
18	Diaphragm	Rubber	Membrane	Caoutchouc	Membrana	Gomma
19	Diaphragm cover	Technopolymer	Couvercle de membrane	Polymère technique	Coperchio membrana	Tecnopolimero
20	Upper bracket	Cast iron	Support supérieur	Fonte grise	Supporto superiore	Ghisa grigia

Bolts and nuts in stainless steel.

Visserie en acier inox

Bulloneria in acciaio inox



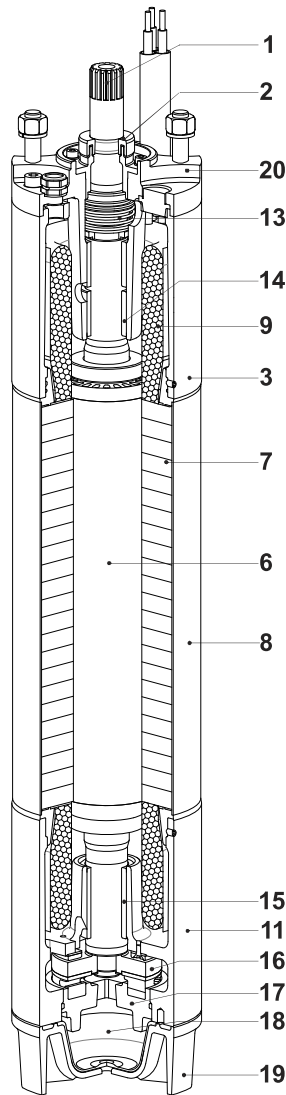

Pos.	Parts	Materials	Nomenclature	Matériaux	Nomenclatura	Materiale
1	Shaft	Stainless steel	Arbre	Acier inox	Albero	Acciaio inox
2	Sand guard	Rubber	para-sable	Caoutchouc	Parasabbia	Gomma
3	Connecting flange	Cast iron	Support intermediaire	Fonte grise	Elemento di raccordo	Ghisa grigia
6	Rotor	Electrical steel	Rotor	Tôle magnétique	Rotore	Lamierino magnetico
7	Stator	Electrical steel	Stator	Tôle magnétique	Statore	Lamierino magnetico
8	Stator shell	Stainless steel	Chemise de stator	Acier inox	Camicia statore	Acciaio inox
9	Winding	HT wire	Bobinage	Fil HT	Avvolgimento	Filo HT
11	Lower bracket	Cast iron	Support inférieur	Fonte grise	Supporto inferiore	Ghisa grigia
13	Mechanical seal	Silicon carbide/silicon carbide	Garniture mécanique	Carbure de silicium/ carbure de silicium	Tenuta meccanica	Carburo di silicio/ carburo di silicio
14-15	Bearing bush	HT Composite	Coussinet	HT Composite	Bussola	Composito HT
16	Thrust-bearing	Stainless steel/ Synthetic compound	Butée	Acier inox/Composé synthétique	Reggispinta	Acciaio inox/ Composto sintetico
16	Thrust-bearing	Brass/Synthetic compound	Butée	Laiton/Composé synthétique	Reggispinta	Ottone/Composto sintetico
17	Thrust-bearing foot slip	Cast iron	Support butée	Fonte grise	Supporto reggispinta	Ghisa grigia
18	Diaphragm	Rubber	Membrane	Caoutchouc	Membrana	Gomma
19	Diaphragm cover	Cast iron	Couvercle de membrane	Fonte grise	Coperchio membrana	Ghisa grigia
20	Upper bracket	Cast iron	Support supérieur	Fonte grise	Supporto superiore	Ghisa grigia

Bolts and nuts in stainless steel.

Visserie en acier inox

Bulloneria in acciaio inox

- a) The normal construction version of **Desert** line submersible electric pumps is designed for lifting water chemically and mechanically non-aggressive for the components.
- b) Maximum content of solids, the same hardness and granulometry of silt: E4XED - E6XD 300 g/m<sup>3</sup>
- c) Maximum operating time when the outlet is closed and the pump is submersed: 3 min.
- d) The hydraulic performance characteristics were measured with 400 V powered motors, cold water (15°C) and atmospheric pressure (1 bar). They are guaranteed as conforming to standard UNI/ISO 9906 Grade 3B.  
 The hydraulic characteristics of units coupled to MAC 6...-2B 6" motors are guaranteed as conforming to standard UNI/ISO 9906 Grade 2B.
- The catalogue given data refer to liquids with a density of 1 kg/dm<sup>3</sup> and kinematic viscosity of not more than 1 mm<sup>2</sup>/s, are comprehensive of friction losses in the check valves.
- e) UPON REQUEST  
 - Pumps can be tested according to UNI/ISO 9906 Grade 2B.  
 - Special executions can be supplied with:  
 • for horizontal installation, if not usually foreseen.
- f) Extra performance:  
 Pumps for specific applications with a high percentage of solids and sand:  
 E4XPD60 - E6XPD52 450 g/m

- a) *Les électropompes immergées ligne Desert, dans la version à fabrication standard, sont adaptées au relevage d'eau qui n'est pas chimiquement et mécaniquement agressive pour les matériaux des composants.*
- b) *Contenu maximum des substances solides de la dureté et la granulométrie du limon: E4XED - E6XD 300 g/m<sup>3</sup>*
- c) *Temps maximum de fonctionnement, à vanne fermée et pompe submergée: 3 min.*
- d) *Les caractéristiques hydrauliques de fonctionnement ont été mesurées avec des moteurs à 400 V, avec de l'eau froide (15° C) à une pression atmosphérique (1bar). Elles sont garanties conformes à la norme UNI/ISO 9906 Niveau 3B.  
 Pour les groupes accouplés à des moteurs 6" MAC 6..-2B les caractéristiques hydrauliques sont garanties conformes à la norme UNI/ISO 9906 Niveau 2B.*
- Les données du catalogue se réfèrent à un liquide pompé de densité de 1 kg/dm<sup>3</sup> et avec une viscosité cinématique non supérieure à 1 mm<sup>2</sup>/s.  
 Elles comprennent les pertes de charge dans les clapets de retenue.*
- e) **SUR DEMANDE**  
 - *Les pompes peuvent être testées selon les normes UNI/ISO 9906 Niveau 2B.*  
 - *Nous pouvons fournir des exécutions spéciales:*  
 • *pour installation horizontale si pas normalement prévue.*
- f) **Extra performance:**  
*Pompes pour applications spécifiques à haute teneur en solides et sable:  
 E4XPD60 - E6XPD52 450 g/m<sup>3</sup>.*

- a) **Le elettropompe sommersa linea Desert, nella normale versione costruttiva, sono adatte al sollevamento di acqua chimicamente e meccanicamente non aggressiva per i materiali dei componenti.**
- b) **Contenuto massimo di sostanze solide della durezza e granulometria del limo: E4XED - E6XD 300 g/m<sup>3</sup>**
- c) **Tempo massimo di funzionamento a bocca chiusa e pompa sommersa: 3 min.**
- d) **Le caratteristiche idrauliche di funzionamento sono state rilevate con motori alimentati a 400 V, con acqua fredda (15° C) alla pressione atmosferica (1bar).  
 Vengono garantite secondo la norma UNI/ISO 9906 Grado 3B.  
 Per i gruppi accoppiati a motori 6" MAC 6...-2B le caratteristiche idrauliche vengono garantite secondo la norma UNI/ISO 9906 Grado 2B.**
- I dati di catalogo si riferiscono a liquidi con densità di 1 kg/dm<sup>3</sup> e con viscosità cinematica non superiore a 1 mm<sup>2</sup>/s, e sono comprensivi delle perdite di carico nelle valvole di ritegno.**
- e) **SU RICHIESTA**  
 - **Possono essere collaudate secondo le norme UNI/ISO 9906 Grado 2B.**  
 - **Possono essere fornite esecuzioni speciali:**  
 • **per installazione in orizzontale, quando non già prevista.**
- f) **Extra performance:**  
**Pompe per applicazioni specifiche ad alto contenuto di solidi e sabbia:  
 E4XPD60 - E6XPD52 450 g/m<sup>3</sup>**

- |   |  |  |
|---|--|--|
| <p>a) Maximum submersion: 150 m<br/>Speed of the water outside the jacket of the motor higher:<br/>0,08 m/s for motors 4"<br/>0,1 m/s for motors MAC...A (5-15 cv)<br/>0,2 m/s for motors MAC...A (17-40 cv)<br/>0,1 m/s for motors MAC...B (50 cv)<br/>0,3 m/s for motors MAC...B (60 cv)</p> <p>b) STANDARD VERSION - THREE-PHASE/50 Hz supply voltage</p> <p>Direct starting:<br/>MC-MAC...-8;<br/>400 V for all power outputs<br/>All the motors are fit for operation with an inverter, but in compliance with the following instructions:<br/>a filter is to be provided between the motor and the inverter to keep the voltage gradient (contact the sales network).</p> <p>MAC6..<br/>MAC6..-2A<br/>Submersible motor with high efficiency. (standard motor)</p> <p>c) VERSION ON REQUEST - THREE-PHASE/50 Hz supply voltage<br/>4" MC...-6V 230V fino a 7,5 kW<br/>6": MAC6..-2B / -2C<br/>230 V up to 30 kW,<br/>MAC...-7 230/400 V up to 37 kW<br/>MAC...-9 400/700 V up to 45 kW</p> <p>In addition, motors can be supplied:<br/>- for other voltages and frequencies<br/>- single-phase motors<br/>MC..M.-1 220/230 V up to 2,2 kW<br/>MC..M.-2 230/240 V up to 2,2 kW<br/>- with special materials for aggressive water</p> <p>MAC6..<br/>MAC6..-2B / -2C<br/>Submersible motor specified for high temperature or for huge sand's content. For any further information please do not hesitate to contact our service network.</p> <p>d) Permissible variations on the stated supply voltages without brackets:<br/>4";6": (220 V), 230 V, (240 V) ± 10%<br/>(380 V), 400 V, (415 V) ± 10%<br/>single-phase motors 4 " : ± 5%<br/>4"-6": for other voltages and frequencies ± 5%</p> <p>Tolerances on the operating data: according to the International Standards IEC 34-1.<br/>Thermal probes on request with 4 m of cable outlet.</p> | <p>a) <i>Immersion maximum : 150 m<br/>Vitesse de l'eau à l'extérieur de la chemise du moteur supérieure à :<br/>0,08 m/s pour moteurs 4"<br/>0,1 m/s pour moteurs MAC...A (5-15 cv)<br/>0,2 m/s pour moteurs MAC...A (17-40 cv)<br/>0,1 m/s pour moteurs MAC...B (50 cv)<br/>0,3 m/s pour moteurs MAC...B (60 cv)</i></p> <p>b) <i>EXECUTION STANDARD - Tension d'alimentation TRIPHASEE/50 Hz</i></p> <p><i>Démarrage direct :<br/>MC-MAC...-8;<br/>400 V pour toutes les puissances<br/>Tous les moteurs sont adaptés au fonctionnement à variateur de fréquence mais d'après les prescriptions suivantes: un filtre entre le moteur et le variateur de fréquence est à prévoir pour maintenir le gradient de tension (contacter le réseau de vente).</i></p> <p>MAC6..<br/>MAC6..-2A<br/>Moteur submersible avec prestations élevées. (moteur standard)</p> <p>c) <i>EXECUTION SUR DEMANDE - Tension d'alimentation TRIPHASEE/50 Hz<br/>4": MC...-6V 230V fino a 7,5 kW<br/>6": MAC6..-2B / -2C<br/>230 V jusqu'à 30 kW,<br/>MAC...-7 230/400 V jusqu'à 37 kW<br/>MAC...-9 400/700 V jusqu'à 45 kW</i></p> <p><i>En outre, des moteurs peuvent être fournis :<br/>- pour tensions et fréquences différentes<br/>- monophasés<br/>MC..M.-1 220/230 V jusqu'à 2,2 kW<br/>MC..M.-2 230/240 V jusqu'à 2,2 kW<br/>- avec matériaux spéciaux pour eau agressive.</i></p> <p>MAC6..<br/>MAC6..-2B / -2C<br/>Moteur submersible spécifique pour utilisation à haute température ou à haut contenu de sable.<br/><i>pour toute information complémentaire, n'hésitez pas à contacter notre réseau de vente.</i></p> <p>d) <i>Variations admises sur les tensions d'alimentation indiquées sans parenthèses :<br/>4";6" : (220 V), 230 V, (240 V) ± 10%<br/>(380 V), 400 V, (415 V) ± 10%<br/>monophasés 4" : ± 5%<br/>4"-6 " : pour tensions et fréquences différentes ± 5%</i></p> <p><i>Tolérances sur les caractéristiques de fonctionnement : selon les normes internationales IEC 34-1.<br/>Sondes thermiques sur demande avec 4 m de sortie de câble.</i></p> | <p>a) <b>Battente massimo: 150 m<br/>Velocità dell'acqua all'esterno della camicia del motore superiore:<br/>0,08 m/s per motori 4"<br/>0,1 m/s per motori MAC...A (5-15 cv)<br/>0,2 m/s per motori MAC...A (17-40 cv)<br/>0,1 m/s per motori MAC...B (50 cv)<br/>0,3 m/s per motori MAC...B (60 cv)</b></p> <p>b) <b>ESECUZIONE STANDARD - Tensione di alimentazione TRIFASE/50 Hz</b></p> <p><b>Avviamento diretto:<br/>MC-MAC...-8;<br/>400V per tutte le potenze<br/>Tutti i motori sono idonei al funzionamento con inverter ma secondo le seguenti prescrizioni: tra inverter e motore aggiungere un filtro per attenuare il gradiente di tensione (contattare la rete di vendita)</b></p> <p><b>MAC6..<br/>MAC6..-2A<br/>Motore sommerso ad alte prestazioni. (motore standard)</b></p> <p>c) <b>ESECUZIONE DISPONIBILI - Tensione di alimentazione TRIFASE/50 Hz<br/>4": MC...-6V 230V fino a 7,5 kW<br/>6": MAC6..-2B / -2C<br/>230 V fino a 30 kW,<br/>MAC...-7 230/400 V fino a 37 kW<br/>MAC...-9 400/700 V fino a 45 kW</b></p> <p><b>Possono inoltre essere forniti motori:<br/>- per tensioni e frequenze diverse<br/>- monofase<br/>MC..M.-1 220/230 V fino a 2,2 kW<br/>MC..M.-2 230/240 V fino a 2,2 kW<br/>- con materiali speciali per acqua aggressiva.</b></p> <p><b>MAC6..<br/>MAC6..-2B / -2C<br/>Motore sommerso per utilizzo ad alte temperature o alti contenuti di sabbia. Per ulteriori informazioni contattare la nostra rete di vendita</b></p> <p>d) <b>Variazioni ammesse sulle tensioni di alimentazione indicate senza parentesi:<br/>4"; 6": (220 V), 230 V, (240 V) ± 10%<br/>(380 V), 400 V, (415 V) ± 10%<br/>monofase 4" ± 5%<br/>4"-6": per tensioni/frequenze diverse ± 5%</b></p> <p><b>Tolleranze sulle caratteristiche di funzionamento: secondo le Norme Internazionali IEC 34-1.<br/>Sonde termiche su richiesta con 4 m di cavo uscente.</b></p> |
|---|--|--|

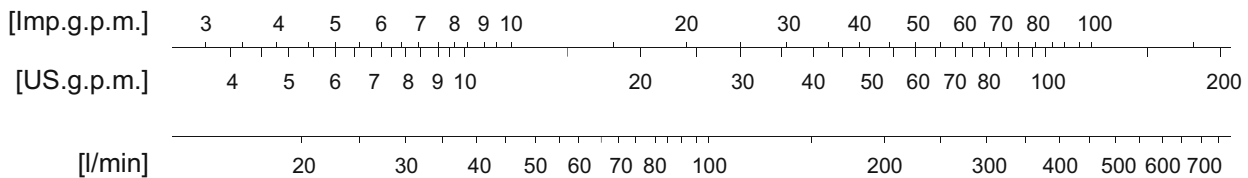
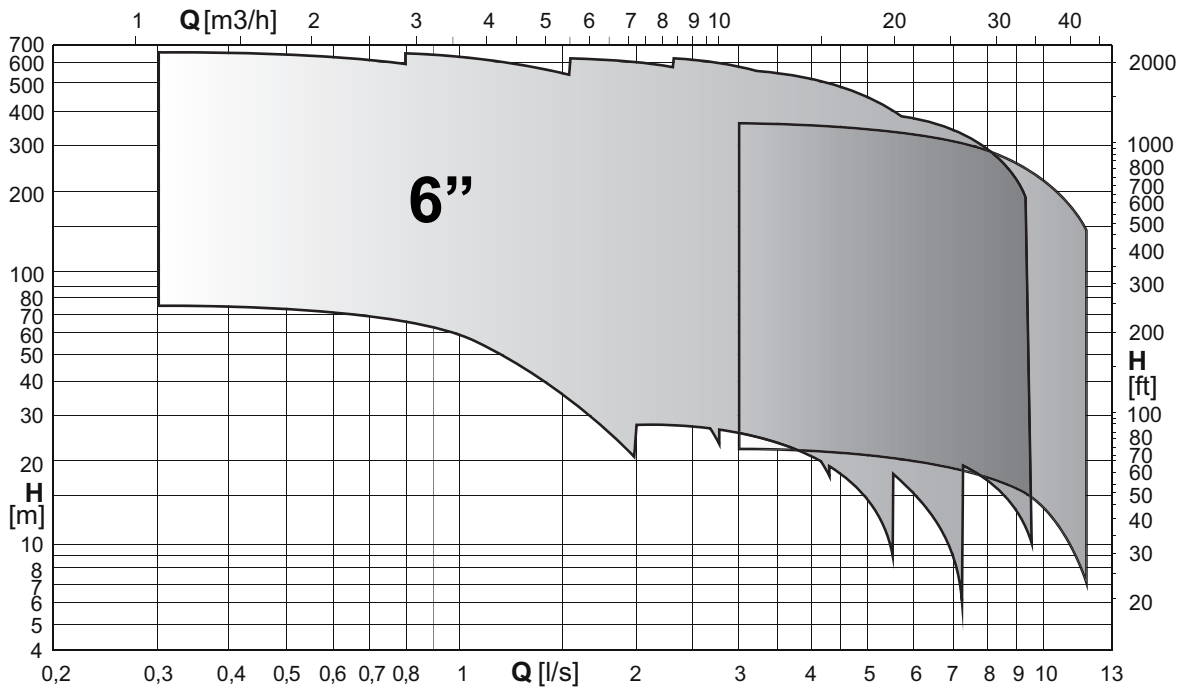
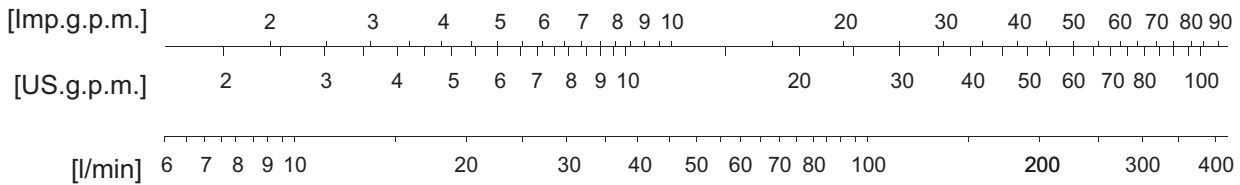
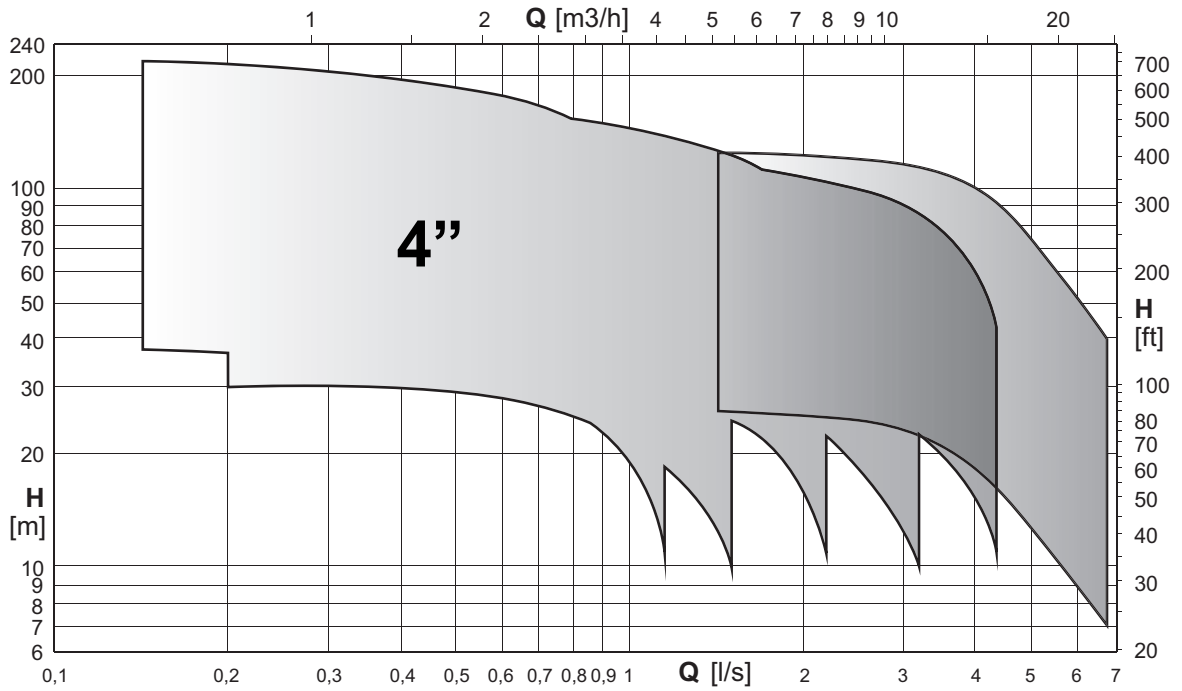

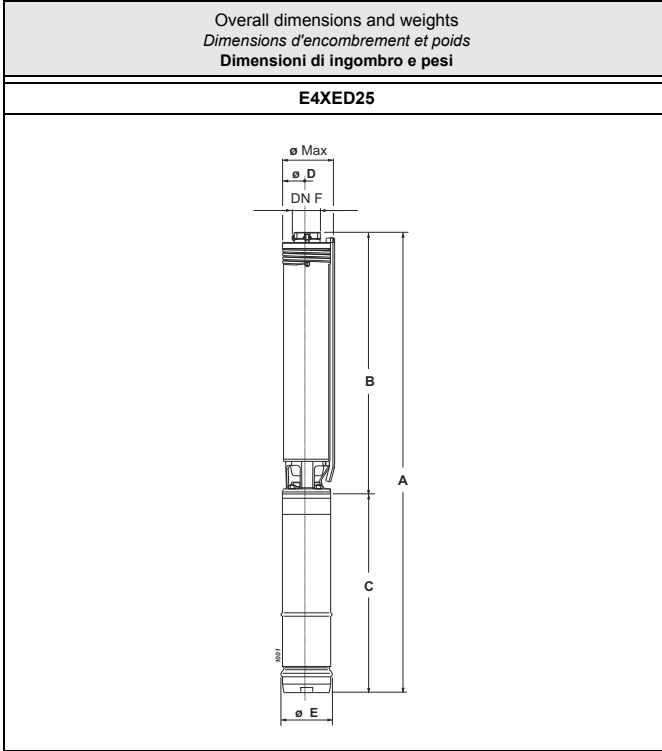

Type Type Tipo	Ø max	Weight Poids Peso	A	B	C	D	E	F
	[mm]							
E4XED25/6+MC405	98	10,6	619,5	299,5	320	93	96	G1 1/4
E4XED25/9+MC4075	98	11,7	699,5	359,5	340	93	96	G1 1/4
E4XED25/12+MC41	98	13	759,5	419,5	340	93	96	G1 1/4
E4XED25/18+MCH415	98	15,2	959,5	539,5	420	93	96	G1 1/4
E4XED25/25+MCH42	98	17,3	1154	707	447	93	96	G1 1/4
E4XED25/31+MCK43	98	19,9	1302	827	475	93	96	G1 1/4
E4XED25/37+MCK43	98	21	1422	947	475	93	96	G1 1/4

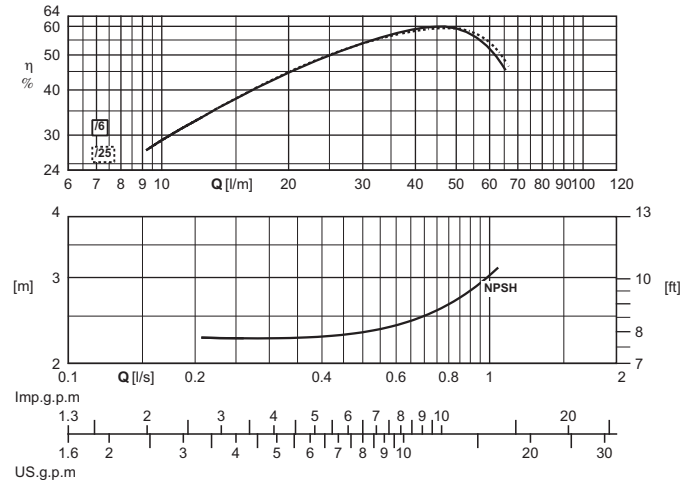
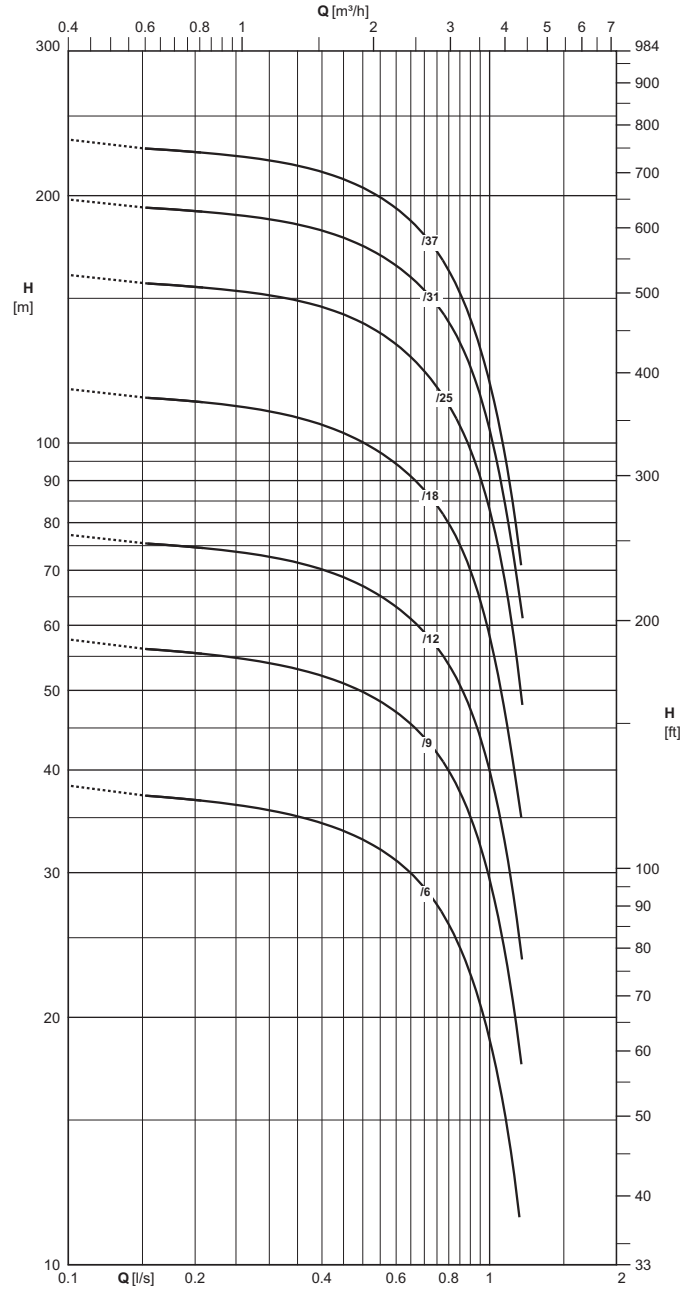

The hydraulic performance characteristics are guaranteed as conforming to standard UNI/ISO 9906 Grade 3B.

Les caractéristiques hydrauliques de fonctionnement sont garanties conformes à la norme UNI/ISO 9906 Niveau 3B.

Le caratteristiche di funzionamento vengono garantite secondo la norma: UNI/ISO 9906 Grado 3B.

Electric pump type Electropompe type Elettropompa tipo	Motor power Puiss. moteur Potenza motore		Horizontal installation Installation horizontale Installazione orizzontale	Check valve $\varnothing$ Clapet de retenue $\varnothing$ Valvola di ritegno $\varnothing$	Capacity Debit Portata										
					[l/s]	0	0,2	0,3	0,4	0,5	0,6	0,7	0,8	0,9	1
	[l/min]	0			12	18	24	30	36	42	48	54	60		
	[m <sup>3</sup> /h]	0			0,7	1,1	1,4	1,8	2,2	2,5	2,9	3,2	3,6		
[kW]	[HP]	Head Hauteur Prevalenza													
E4XED25/6+MC405	0,37	0,5	○	11/4" Gas	[m]	38,5	37	35,5	34,5	33	31	28,5	26	22,5	19
E4XED25/9+MC4075	0,55	0,8	○	11/4" Gas	[m]	58	55	54	52	50	47	44	40	35	29,5
E4XED25/12+MC41	0,75	1	○	11/4" Gas	[m]	77	75	73	70	67	63	59	54	47,5	40
E4XED25/18+MCH415	1,1	1,5	○	11/4" Gas	[m]	116	112	109	105	100	94	88	80	70	58
E4XED25/25+MCH42	1,5	2	○	11/4" Gas	[m]	160	155	151	146	140	132	122	111	98	83
E4XED25/31+MCK43	2,2	3	○	11/4" Gas	[m]	198	191	187	181	174	164	153	140	124	104
E4XED25/37+MCK43	2,2	3	○	11/4" Gas	[m]	234	226	221	214	204	193	179	162	141	118
NPSH					[m]	-	-	2,3	2,3	2,3	2,4	2,7	2,8	2,8	3
M.E.I. $\geq$ 0.10															

■ Without conical valve

□ On request

○ Please contact our sales organisation

For motor performances specification see page "motor features"

Temperature monitoring device for submersed electric motors 4" + 6": see page "Accessories"

■ Sans soupape du clapet.

□ Sur demande

○ Contacter notre service commercial.

Pour caractéristiques techniques moteurs voir page "Caractéristiques des moteurs"

Appareillage de contrôle de la température des moteurs électriques immergés 4" + 6": voir page "Accessories"

■ Senza clapet valvola di ritegno

□ Su richiesta

○ Interpellare la sede o la rete di vendita

Per caratteristiche motori vedere pagina caratteristiche motori

Apparecchiatura di controllo temperatura motori elettrici sommersi 4" + 6": vedere pagina accessori

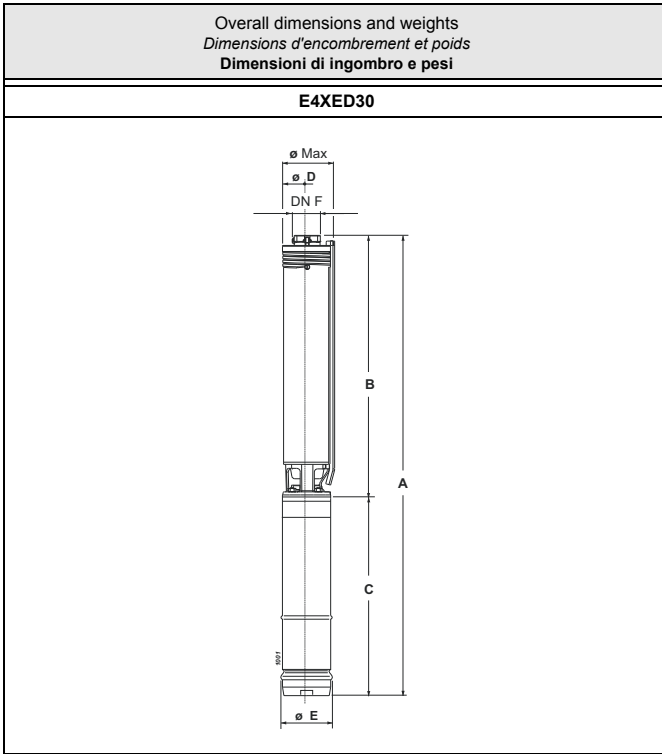

Type Type Tipo	Ø max	Weight Poids Peso	A	B	C	D	E	F
	[mm]							
E4XED30/5+MC405	98	9,9	628,5	308,5	320	93	96	G1 1/4
E4XED30/8+MC4075	98	11,7	723,5	383,5	340	93	96	G1 1/4
E4XED30/11+MC41	98	12,9	798,5	458,5	340	93	96	G1 1/4
E4XED30/16+MCH415	98	15,2	1003,5	583,5	420	93	96	G1 1/4
E4XED30/21+MCH42	98	17,2	1183	736	447	93	96	G1 1/4
E4XED30/32+MCK43	98	20,9	1486	1011	475	93	96	G1 1/4

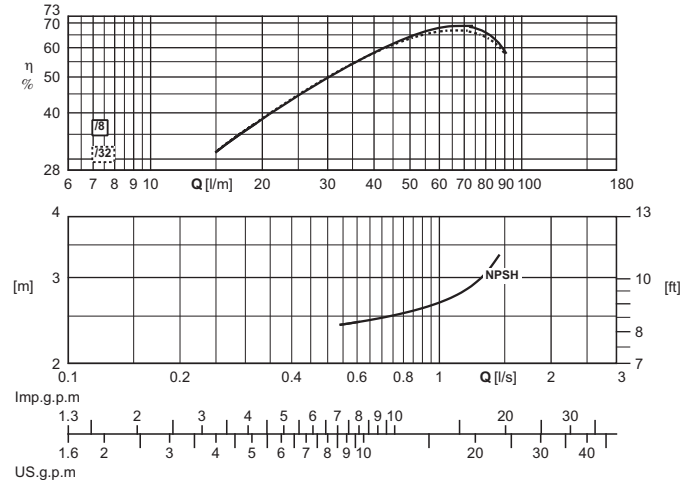
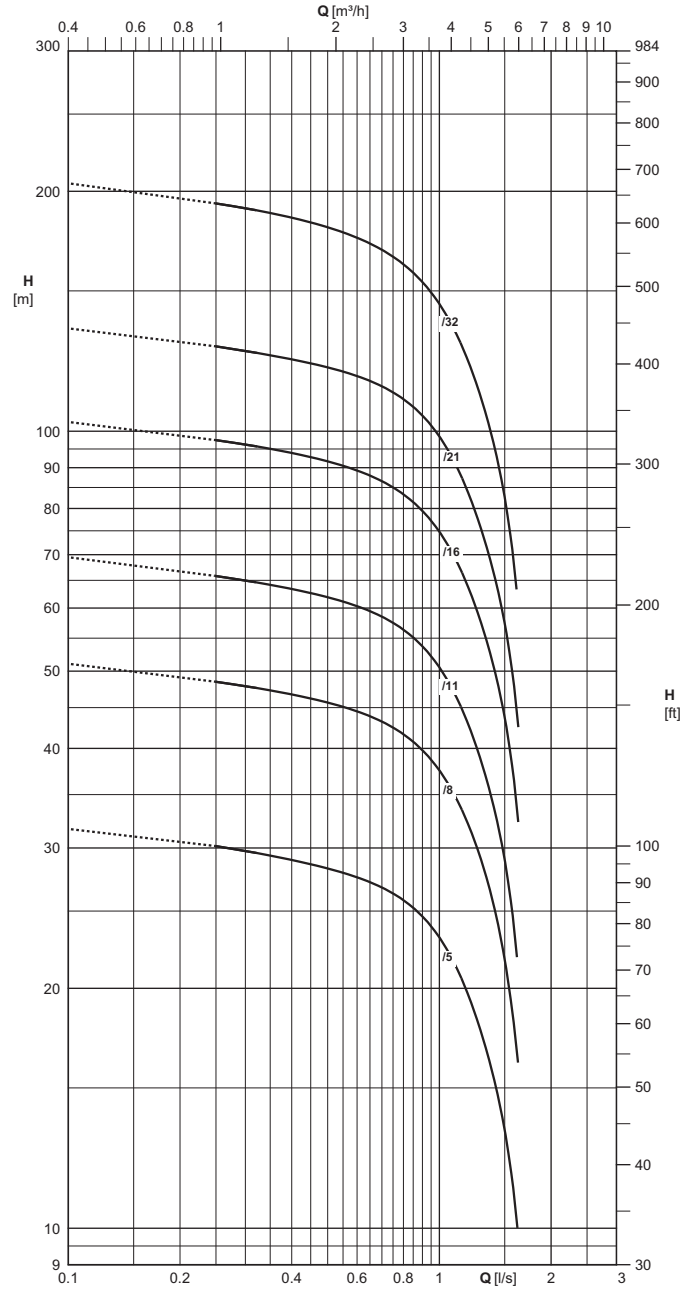

The hydraulic performance characteristics are guaranteed as conforming to standard UNI/ISO 9906 Grade 3B.

Les caractéristiques hydrauliques de fonctionnement sont garanties conformes à la norme UNI/ISO 9906 Niveau 3B.

Le caratteristiche di funzionamento vengono garantite secondo la norma: UNI/ISO 9906 Grado 3B.

Electric pump type Electropompe type Elettropompa tipo	Motor power Puisse. moteur Potenza motore		Horizontal installation Installation horizontale Installazione orizzontale	Check valve Ø Clapet de retenue Ø Valvola di ritegno Ø	Capacity Debit Portata												
					[l/s]	0	0,3	0,4	0,5	0,6	0,7	0,8	0,9	1	1,2	1,4	1,6
	[l/min]	0			18	24	30	36	42	48	54	60	72	84	96		
	[m³/h]	0			1,1	1,4	1,8	2,2	2,5	2,9	3,2	3,6	4,3	5	5,8		
[kW]	[HP]	Head Hauteur Prevalenza															
E4XED30/5+MC405	0,37	0,5	○	11/4" Gas	[m]	31,5	29,5	29	28,5	27,5	27	26	24,5	23	19,5	15,5	10,5
E4XED30/8+MC4075	0,55	0,8	○	11/4" Gas	[m]	51	48	46,5	45,5	44,5	43	41,5	40	37,5	32	25,5	17,5
E4XED30/11+MC41	0,75	1	○	11/4" Gas	[m]	69	65	63	62	60	58	56	54	50	42,5	34	23
E4XED30/16+MCH415	1,1	1,5	○	11/4" Gas	[m]	103	96	94	92	89	86	83	79	75	63	51	35
E4XED30/21+MCH42	1,5	2	○	11/4" Gas	[m]	134	126	123	120	117	114	109	104	98	83	66	46,5
E4XED30/32+MCK43	2,2	3	○	11/4" Gas	[m]	205	190	185	180	175	169	162	154	144	122	96	66
NPSH					[m]	-	-	-	-	2,4	2,5	2,5	3,2	2,7	2,9	3,2	-

M.E.I. ≥ 0.10

■ Without conical valve

□ On request

○ Please contact our sales organisation

For motor performances specification see page "motor features"

■ Sans soupape du clapet.

□ Sur demande

○ Contacter notre service commercial.

Pour caractéristiques techniques moteurs voir page "Caractéristiques des moteurs"

■ Senza clapet valvola di ritegno

□ Su richiesta

○ Interpellare la sede o la rete di vendita

Per caratteristiche motori vedere pagina caratteristiche motori

Temperature monitoring device for submersed electric motors 4" + 6": Appareillage de contrôle de la température des moteurs électriques immergés 4" + 6": voir page "Accessories"

Apparecchiatura di controllo temperatura motori elettrici sommersi 4" + 6": vedere pagina accessori



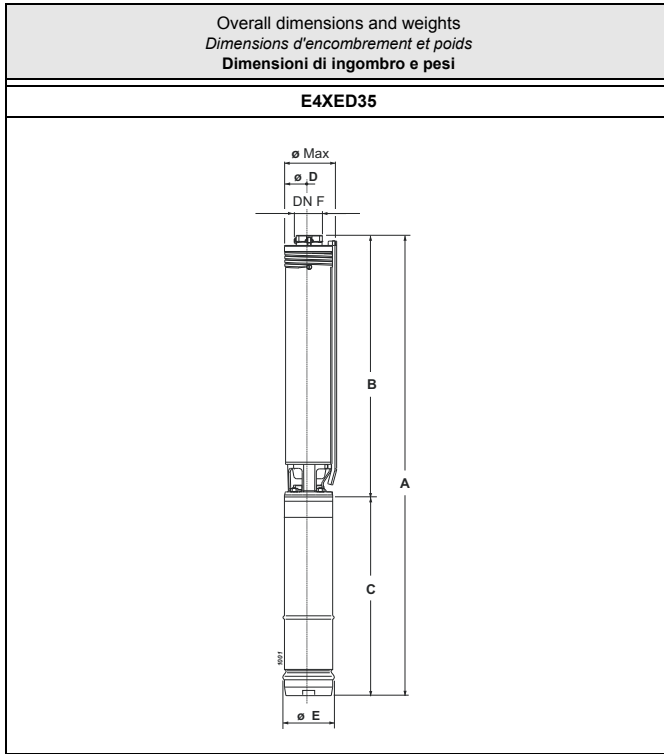

Type Type Tipo	Ø max [mm]	Weight Poids Peso [kg]	A	B	C	D	E	F
			[mm]					
E4XED35/5+MC4075	98	11,3	669,5	329,5	340	93	96	G1 1/4
E4XED35/7+MC41	98	12,5	729,5	389,5	340	93	96	G1 1/4
E4XED35/10+MCH415	98	14,5	899,5	479,5	420	93	96	G1 1/4
E4XED35/14+MCH42	98	16	1046,5	599,5	447	93	96	G1 1/4
E4XED35/20+MCH43	98	19,2	1254,5	779,5	475	93	96	G1 1/4
E4XED35/27+MCH44	98	23,2	1504,5	989,5	515	93	96	G1 1/4

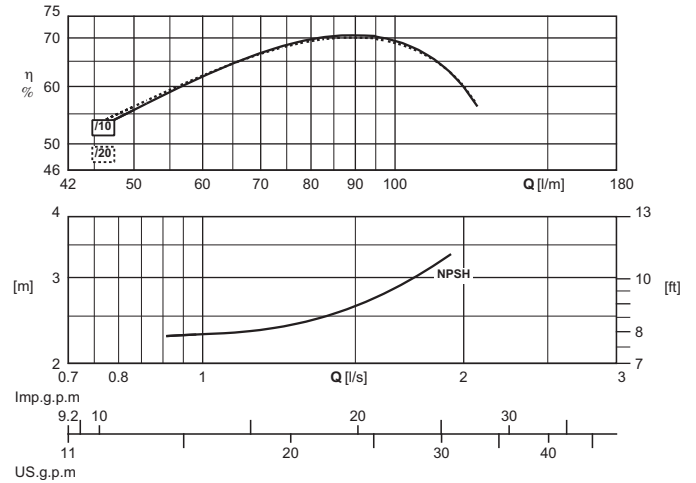
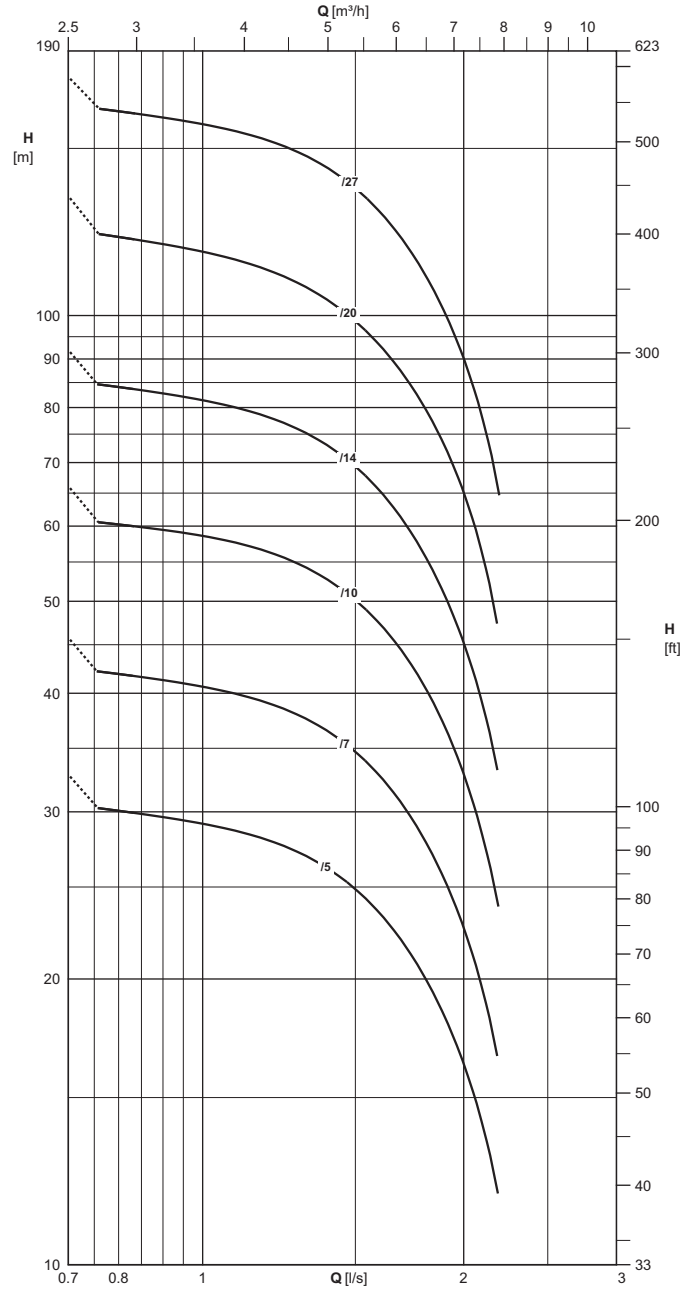

The hydraulic performance characteristics are guaranteed as conforming to standard UNI/ISO 9906 Grade 3B.

Les caractéristiques hydrauliques de fonctionnement sont garanties conformes à la norme UNI/ISO 9906 Niveau 3B.

Le caratteristiche di funzionamento vengono garantite secondo la norma: UNI/ISO 9906 Grado 3B.

Electric pump type Electropompe type Elettropompa tipo	Motor power Puiss. moteur Potenza motore		Horizontal installation Installation horizontale Installazione orizzontale	Check valve Ø Clapet de retenue Ø Valvola di ritegno Ø	Capacity Debit Portata									
					[l/s]	0	0,8	0,9	1	1,2	1,4	1,6	1,8	2
	[l/min]	0			48	54	60	72	84	96	108	120		
	[m³/h]	0			2,9	3,2	3,6	4,3	5	5,8	6,5	7,2		
[kW]	[HP]	Head Hauteur Prevalenza												
E4XED35/5+MC4075	0,55	0,8	○	11/4" Gas	[m]	33	30	29,5	29	28	26	23,5	20	16,5
E4XED35/7+MC41	0,75	1	○	11/4" Gas	[m]	46	42	41,5	40,5	39	36,5	32,5	28	22,5
E4XED35/10+MCH415	1,1	1,5	○	11/4" Gas	[m]	66	60	59	59	56	52	47,5	40,5	33
E4XED35/14+MCH42	1,5	2	○	11/4" Gas	[m]	92	84	83	81	78	73	65	56	45
E4XED35/20+MCH43	2,2	3	○	11/4" Gas	[m]	133	121	119	117	111	103	93	80	65
E4XED35/27+MCH44	3	4	○	11/4" Gas	[m]	178	164	162	159	152	142	129	111	90
NPSH					[m]	-	-	-	2,3	2,4	2,5	2,8	3,1	-
M.E.I. ≥ 0.10														

■ Without conical valve

□ On request

○ Please contact our sales organisation

For motor performances specification see page "motor features"

■ Sans soupape du clapet.

□ Sur demande

○ Contacter notre service commercial.

Pour caractéristiques techniques moteurs voir page "Caractéristiques des moteurs"

■ Senza clapet valvola di ritegno

□ Su richiesta

○ Interpellare la sede o la rete di vendita

Per caratteristiche motori vedere pagina caratteristiche motori

Temperature monitoring device for submersed electric motors 4" + 6": Appareillage de contrôle de la température des moteurs électriques immergés 4" + 6": voir page "Accessories"

Apparecchiatura di controllo temperatura motori elettrici sommersi 4" + 6": vedere pagina accessori

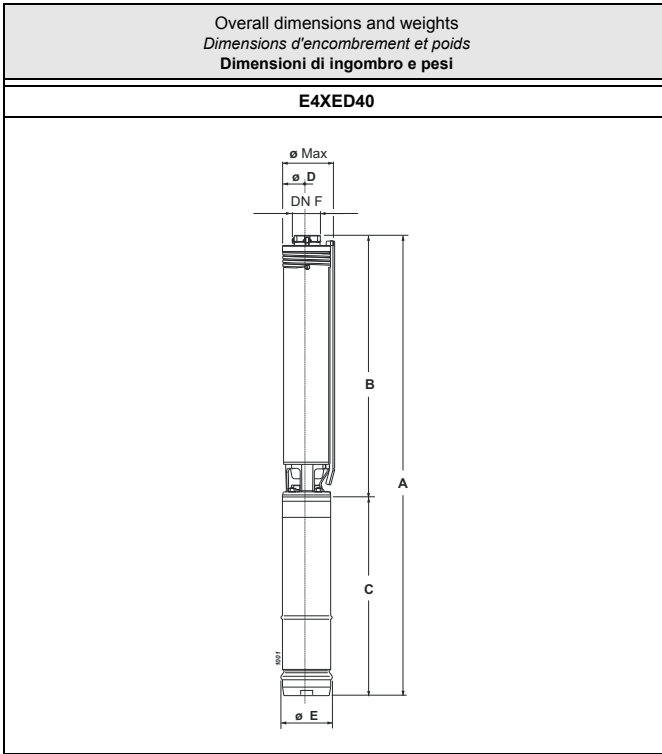

Type Type Tipo	Ø max [mm]	Weight Poids Peso [kg]	A	B	C	D	E	F
			[mm]					
E4XED40/6+MC41	98	12,5	748,5	408,5	340	93	96	G2
E4XED40/9+MCH415	98	14,6	941	521	420	93	96	G2
E4XED40/12+MCH42	98	16,1	1080,5	633,5	447	93	96	G2
E4XED40/17+MCH43	98	19,3	1323,5	848,5	475	93	96	G2
E4XED40/23+MCH44	98	23,4	1588,5	1073,5	515	93	96	G2

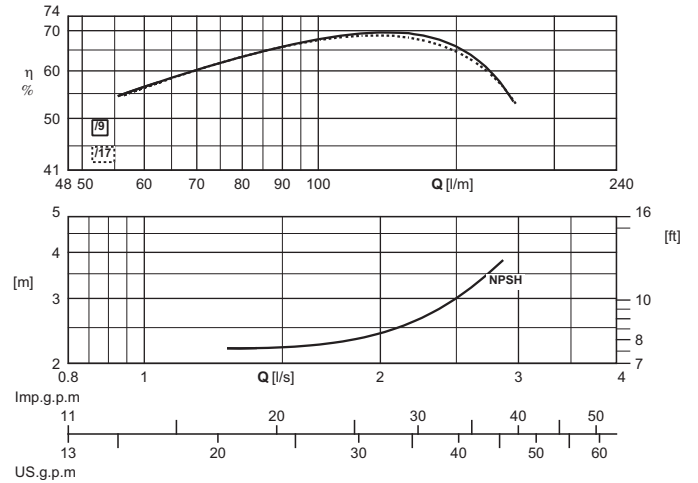
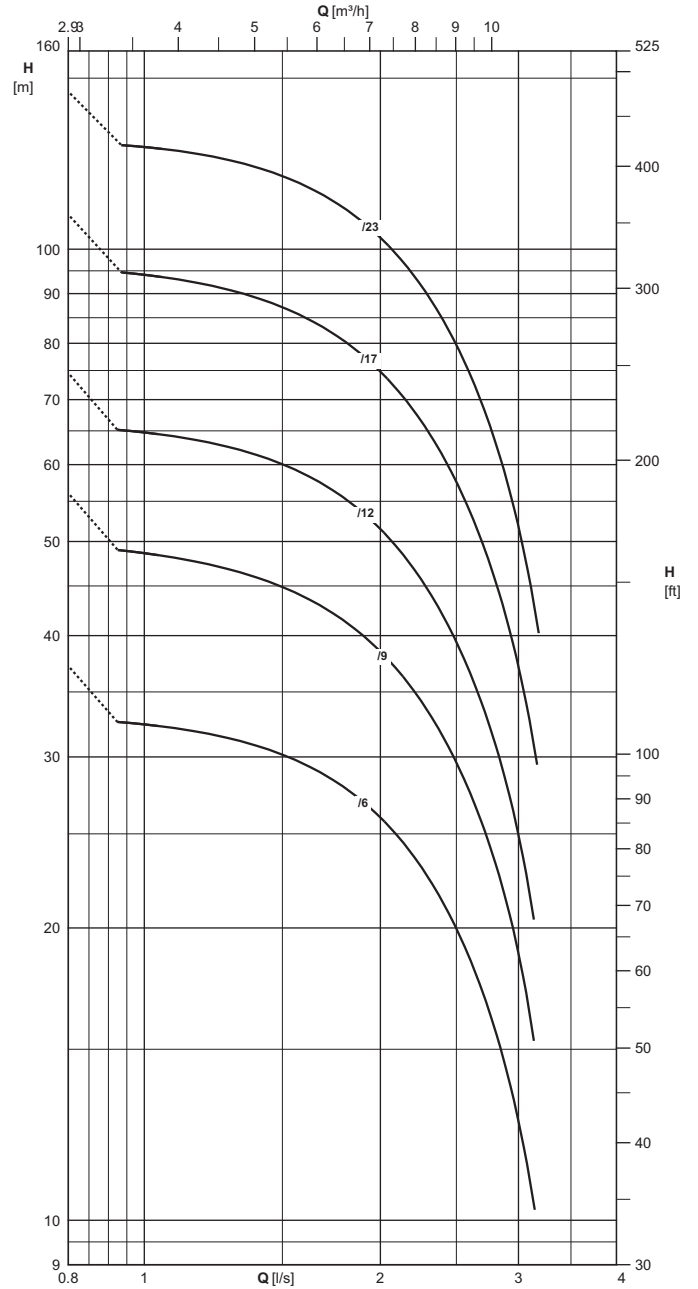

The hydraulic performance characteristics are guaranteed as conforming to standard UNI/ISO 9906 Grade 3B.

Les caractéristiques hydrauliques de fonctionnement sont garanties conformes à la norme UNI/ISO 9906 Niveau 3B.

Le caratteristiche di funzionamento vengono garantite secondo la norma: UNI/ISO 9906 Grado 3B.

Electric pump type Electropompe type Elettropompa tipo	Motor power Puisse. moteur Potenza motore		Horizontal installation Installation horizontale Installazione orizzontale	Check valve $\varnothing$ Clapet de retenue $\varnothing$ Valvola di ritegno $\varnothing$	Capacity Debit Portata												
					[l/s]	0	1	1,2	1,4	1,6	1,8	2	2,2	2,4	2,6	2,8	3
	[l/min]	0			60	72	84	96	108	120	132	144	156	168	180		
	[m <sup>3</sup> /h]	0			3,6	4,3	5	5,8	6,5	7,2	7,9	8,6	9,4	10,1	10,8		
[kW]	[HP]	Head Hauteur Prevalenza															
E4XED40/6+MC41	0,75	1	○	2" Gas	[m]	37	32,5	31,5	31	29,5	28	26	24	21,5	18,5	15,5	12,5
E4XED40/9+MCH415	1,1	1,5	○	2" Gas	[m]	56	48,5	47,5	46	44	41,5	38,5	35	31,5	27,5	23,5	19
E4XED40/12+MCH42	1,5	2	○	2" Gas	[m]	74	65	63	61	59	55	51	47	42	36,5	31	25
E4XED40/17+MCH43	2,2	3	○	2" Gas	[m]	108	94	92	89	85	80	75	68	61	54	45,5	37
E4XED40/23+MCH44	3	4	○	2" Gas	[m]	145	127	125	121	116	110	103	94	85	74	63	52
NPSH					[m]	-	-	-	2,2	2,2	2,3	2,7	2,6	2,8	3,2	4,2	-

M.E.I.  $\geq$  0.10

■ Without conical valve

□ On request

○ Please contact our sales organisation

For motor performances specification see page "motor features"

■ Sans soupape du clapet.

□ Sur demande

○ Contacter notre service commercial.

Pour caracteristiques techniques moteurs voir page "Caracteristiques des moteurs"

■ Senza clapet valvola di ritegno

□ Su richiesta

○ Interpellare la sede o la rete di vendita

Per caratteristiche motori vedere pagina caratteristiche motori

Temperature monitoring device for submersed electric motors 4" + 6": see page "Accessories"

Appareillage de contrôle de la température des moteurs électriques immergés 4" + 6": voir page "Accessories"

Apparecchiatura di controllo temperatura motori elettrici sommersi 4" + 6": vedere pagina accessori

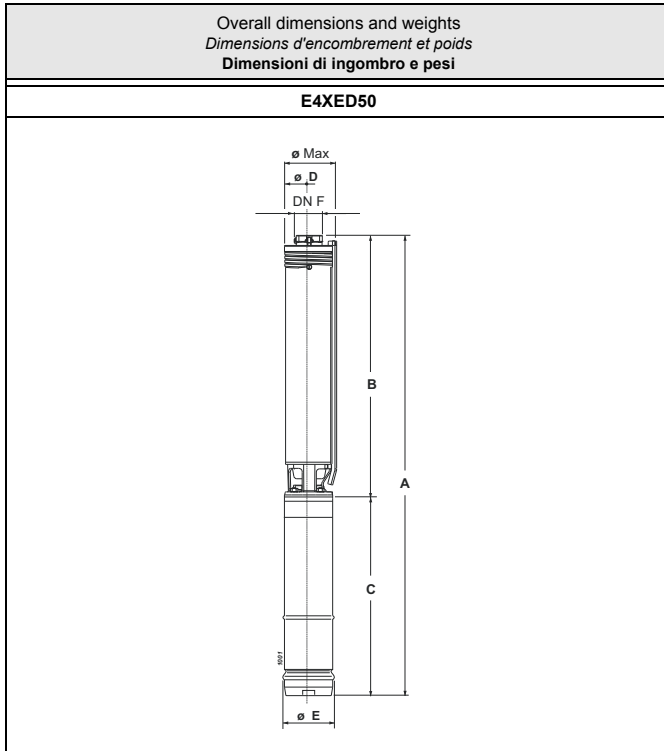

Type Type Tipo	Ø max [mm]	Weight Poids Peso [kg]	A	B	C	D	E	F
			[mm]					
E4XED50/6+MCH415	98	14,1	858,5	438,5	420	93	96	G2
E4XED50/8+MCH42	98	15,4	970,5	523,5	447	93	96	G2
E4XED50/12+MCH43	98	18,5	1196	721	475	93	96	G2
E4XED50/16+MCH44	98	22,3	1406	891	515	93	96	G2
E4XED50/22+MCH455	98	27,5	1686	1146	540	93	96	G2

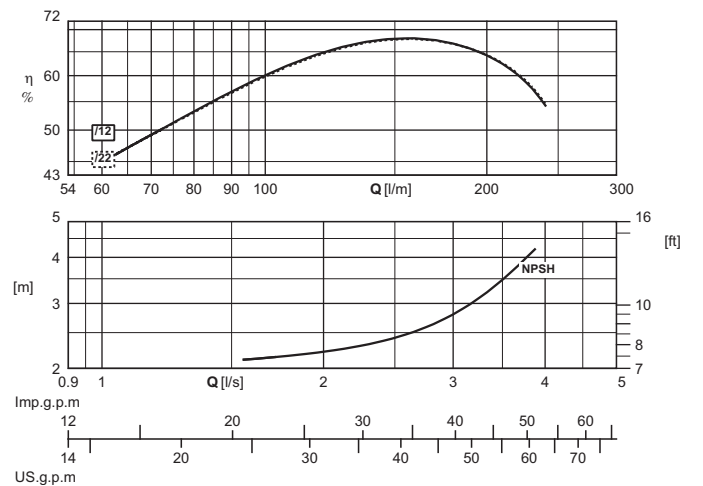
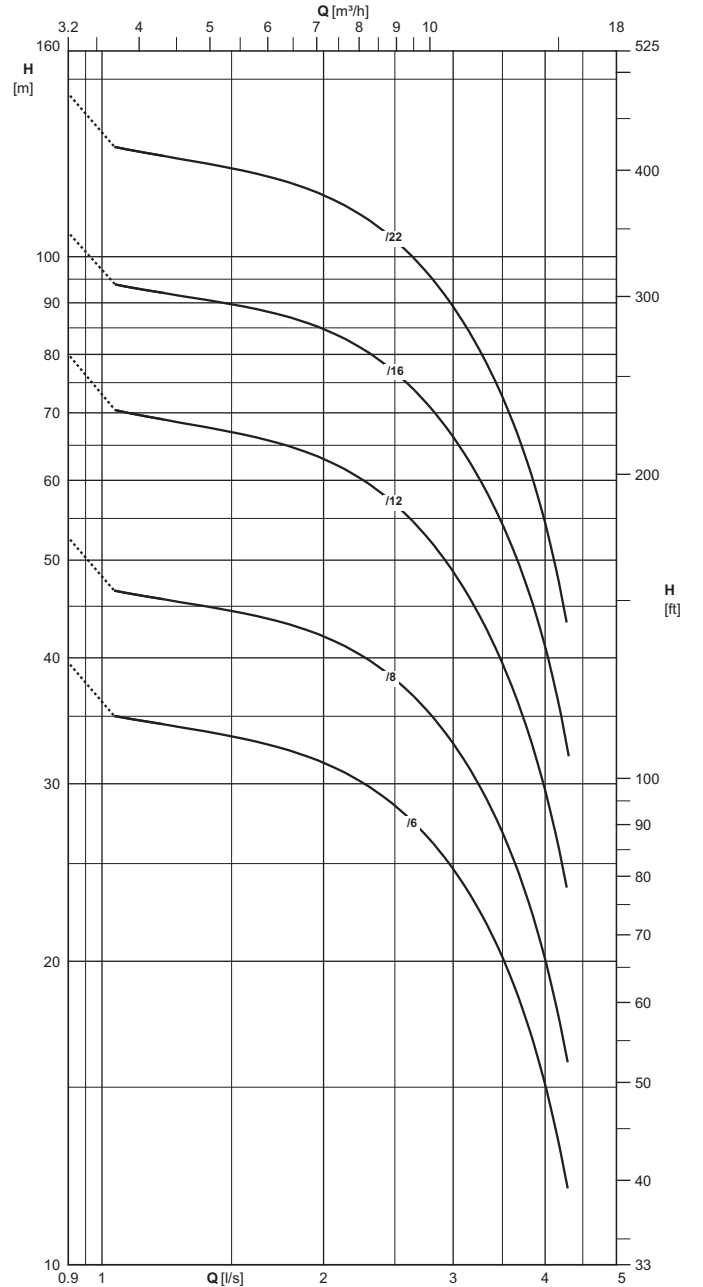

The hydraulic performance characteristics are guaranteed as conforming to standard UNI/ISO 9906 Grade 3B.

Les caractéristiques hydrauliques de fonctionnement sont garanties conformes à la norme UNI/ISO 9906 Niveau 3B.

Le caratteristiche di funzionamento vengono garantite secondo la norma: UNI/ISO 9906 Grado 3B.

Electric pump type Electropompe type Elettropompa tipo	Motor power Puisse. moteur Potenza motore		Horizontal installation Installation horizontale Installazione orizzontale	Check valve Ø Clapet de retenue Ø Valvola di ritegno Ø	Capacity Debit Portata													
					[l/s]	0	1,2	1,4	1,6	1,8	2	2,2	2,4	2,6	2,8	3	3,5	4
	[l/min]	0			72	84	96	108	120	132	144	156	168	180	210	240		
	[m³/h]	0			4,3	5	5,8	6,5	7,2	7,9	8,6	9,4	10,1	10,8	12,6	14,4		
[kW]	[HP]	Head Hauteur Prevalenza																
E4XED50/6+MCH415	1,1	1,5	○	2" Gas	[m]	39,5	34,5	34	33	32,5	31,5	30,5	29	28	26,5	24,5	20	15
E4XED50/8+MCH42	1,5	2	○	2" Gas	[m]	53	46	45	44	43	42	40,5	39	37	35	33	27	20
E4XED50/12+MCH43	2,2	3	○	2" Gas	[m]	80	69	68	66	65	63	61	58	55	52	48,5	39,5	29,5
E4XED50/16+MCH44	3	4	○	2" Gas	[m]	106	92	90	89	87	85	82	78	75	71	66	54	41
E4XED50/22+MCH455	4	5,5	○	2" Gas	[m]	145	126	123	121	118	115	111	106	101	95	89	72	54
NPSH					[m]	-	-	-	2,1	2,2	2,3	2,3	2,4	2,5	2,6	2,8	3,4	-

M.E.I. ≥ 0.10

■ Without conical valve

□ On request

○ Please contact our sales organisation

For motor performances specification see page "motor features"

Temperature monitoring device for submersed electric motors 4" + 6": see page "Accessories"

■ Sans soupape du clapet.

□ Sur demande

○ Contacter notre service commercial.

Pour caractéristiques techniques moteurs voir page "Caractéristiques des moteurs"

Appareillage de contrôle de la température des moteurs électriques immergés 4" + 6": voir page "Accessories"

■ Senza clapet valvola di ritegno

□ Su richiesta

○ Interpellare la sede o la rete di vendita

Per caratteristiche motori vedere pagina caratteristiche motori

Apparecchiatura di controllo temperatura motori elettrici sommersi 4" + 6": vedere pagina accessori

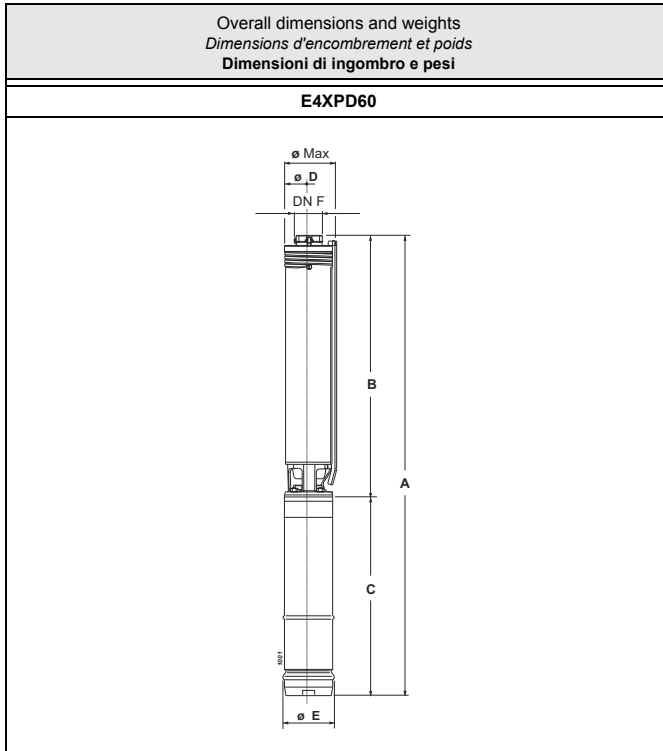

Type Type Tipo	Ø max [mm]	Weight Poids Peso [kg]	A	B	C	D	E	F
			[mm]					
E4XPD60/5+MCH42	98	15,6	1005	558	447	93	96	G2
E4XPD60/7+MCH43	98	18,2	1169	694	475	93	96	G2
E4XPD60/10+MCH44	98	22,4	1440,5	925,5	515	93	96	G2
E4XPD60/13+MCH455	98	27,1	1669,5	1129,5	540	93	96	G2
E4XPD60/18+MCR475	98	35,7	2182	1497	685	93	96	G2
E4XPD60/25+MCR410	98	43,2	2770,5	2000,5	770	93	96	G2

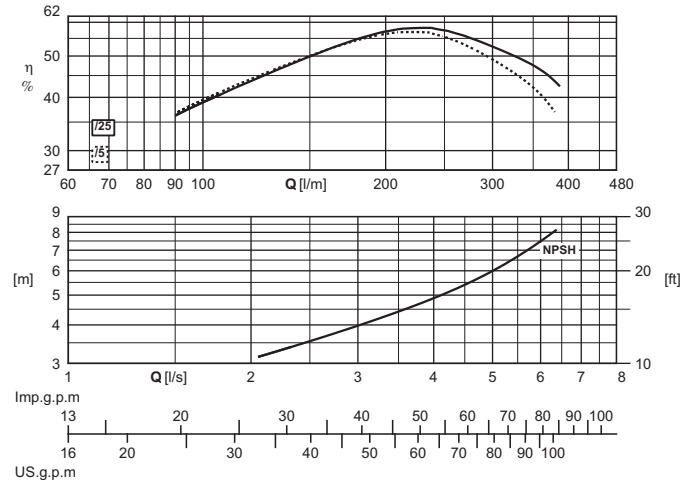
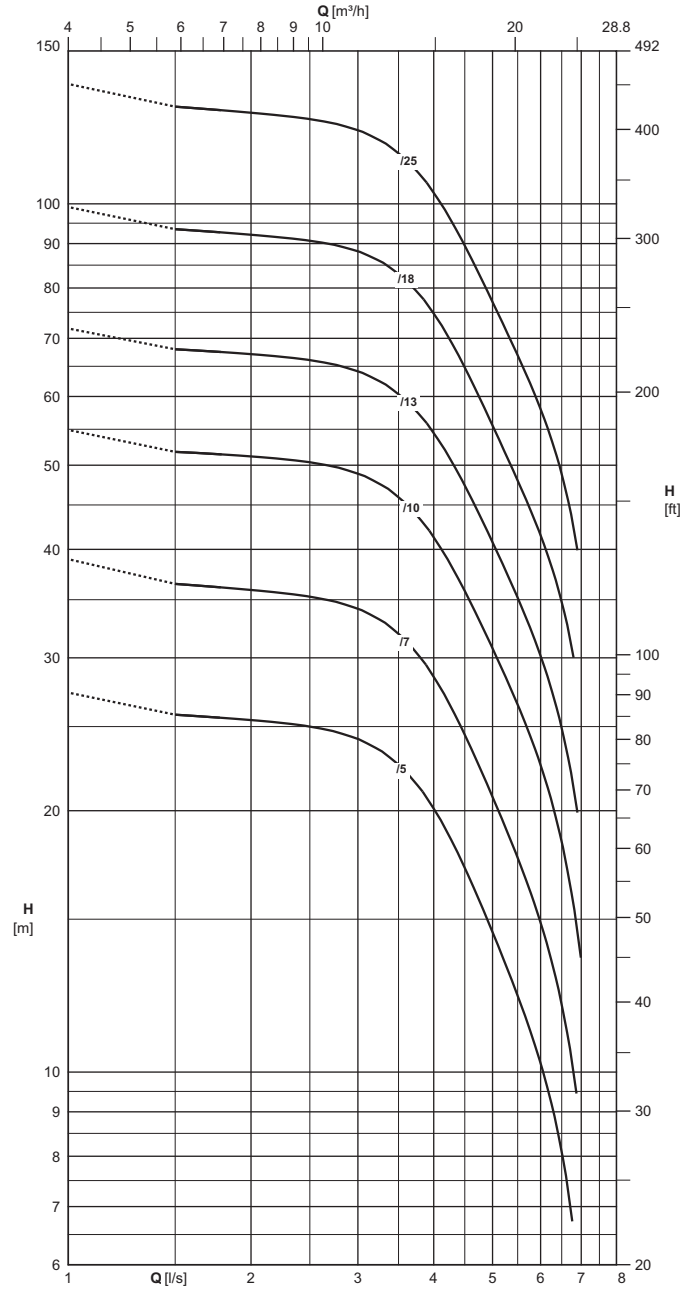

The hydraulic performance characteristics are guaranteed as conforming to standard UNI/ISO 9906 Grade 3B.

Les caractéristiques hydrauliques de fonctionnement sont garanties conformes à la norme UNI/ISO 9906 Niveau 3B.

Le caratteristiche di funzionamento vengono garantite secondo la norma: UNI/ISO 9906 Grado 3B.

Electric pump type Electropompe type Elettropompa tipo	Motor power Puiss. moteur Potenza motore		Horizontal installation Installation horizontale Installazione orizzontale	Check valve $\varnothing$ Clapet de retenue $\varnothing$ Valvola di ritegno $\varnothing$	Capacity Debit Portata																
					[l/s]	0	1,6	1,8	2	2,2	2,4	2,6	2,8	3	3,5	4	4,5	5	5,5	6	6,5
	[l/min]	0			96	108	120	132	144	156	168	180	210	240	270	300	330	360	390		
	[m <sup>3</sup> /h]	0			5,8	6,5	7,2	7,9	8,6	9,4	10,1	10,8	12,6	14,4	16,2	18	19,8	21,6	23,4		
[kW]	[HP]	Head Hauteur Prevalenza																			
E4XPD60/5+MCH42	1,5	2	<input type="radio"/>	2" Gas	[m]	27,5	25,5	25,5	25,5	25,5	25	25	24,5	24	22,5	20	17	14,5	12,5	10	8,1
E4XPD60/7+MCH43	2,2	3	<input type="radio"/>	2" Gas	[m]	39	36,5	36	36	35,5	35,5	35	34,5	34	32	28,5	24,5	21	17,5	15	12
E4XPD60/10+MCH44	3	4	<input type="radio"/>	2" Gas	[m]	55	52	51	51	51	51	50	49,5	49	46	41,5	36	31	26,5	22,5	18,5
E4XPD60/13+MCH455	4	5,5	<input type="radio"/>	2" Gas	[m]	72	68	67	67	67	66	66	65	64	60	54	47,5	41	35	30	25
E4XPD60/18+MCR475	5,5	7,5	<input type="radio"/>	2" Gas	[m]	99	93	93	92	91	91	90	89	88	83	75	65	56	48	41,5	35
E4XPD60/25+MCR410	7,5	10	<input type="radio"/>	2" Gas	[m]	137	129	128	127	126	126	124	123	121	114	103	89	77	67	58	49
NPSH					[m]	-	-	-	-	3,3	3,5	3,6	3,8	4	4,4	4,9	5,4	6	6,7	7,5	-

Without conical valve

On request

Please contact our sales organisation

For motor performances specification see page "motor features"

Temperature monitoring device for submersed electric motors 4" + 6": see page "Accessories"

Sans soupape du clapet.

Sur demande

Contacter notre service commercial.

Pour caracteristiques techniques moteurs voir page "Caracteristiques des moteurs"

Appareillage de contrôle de la température des moteurs électriques immergés 4" + 6": voir page "Accessories"

Senza clapet valvola di ritegno

Su richiesta

Interpellare la sede o la rete di vendita

Per caratteristiche motori vedere pagina caratteristiche motori

Apparecchiatura di controllo temperatura motori elettrici sommersi 4" + 6": vedere pagina accessori



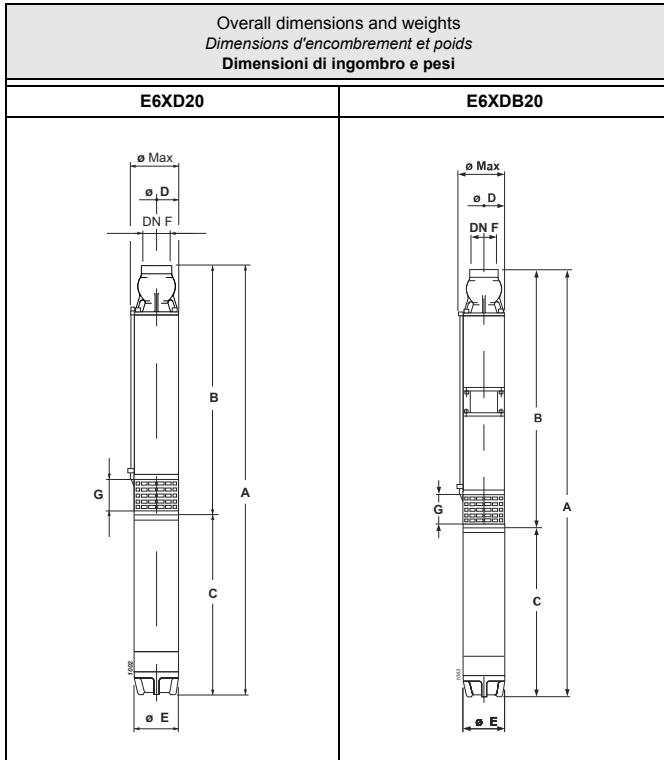

Type Type Tipo	Ø max [mm]	Weight Poids Peso [kg]	[mm]							F
			A	B	C	D	E	G		
E6XD20/9+MCH415	135	21	988	568	420	127	96	100	G2 1/2	
E6XD20/12+MCH42	135	23,5	1105	658	447	127	96	100	G2 1/2	
E6XD20/18+MCK43	135	28,5	1372	897	475	127	96	100	G2 1/2	
E6XD20/24+MCR44	135	37,5	1597	1077	520	127	96	100	G2 1/2	
E6XD20/30+MCR455	135	44	1847	1257	590	127	96	100	G2 1/2	
E6XD20/30+MAC65A	145	53	1822	1292	530	141	143	100	G2 1/2	
E6XDB20/36+MAC67A	145	59	2214	1664	550	141	143	100	G2 1/2	
E6XDB20/40+MAC67A	145	61	2334	1784	550	141	143	100	G2 1/2	
E6XDB20/44+MAC67A	145	63,5	2454	1904	550	141	143	100	G2 1/2	
E6XDB20/50+MAC610A	145	71,5	2679	2084	595	141	143	100	G2 1/2	
E6XDB20/56+MAC610A	145	75	2859	2264	595	141	143	100	G2 1/2	
E6XDB20/63+MAC612A	145	82,5	3114	2474	640	141	143	100	G2 1/2	
E6XDB20/70+MAC612A	145	86,5	3324	2684	640	141	143	100	G2 1/2	
E6XDB20/76+MAC615A	145	92,5	3534	2864	670	141	143	100	G2 1/2	

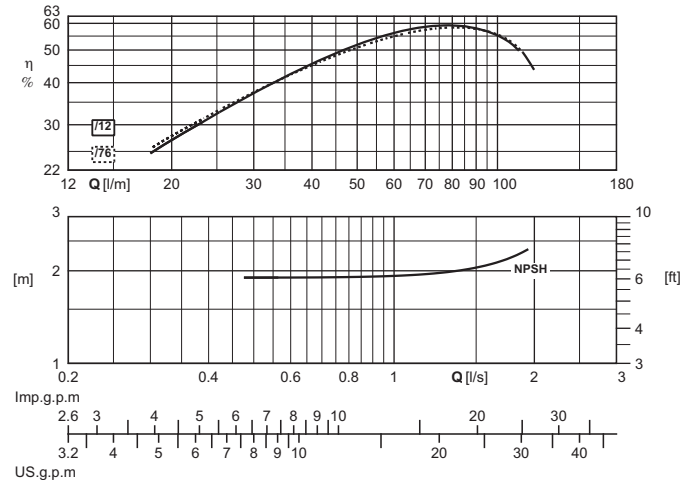
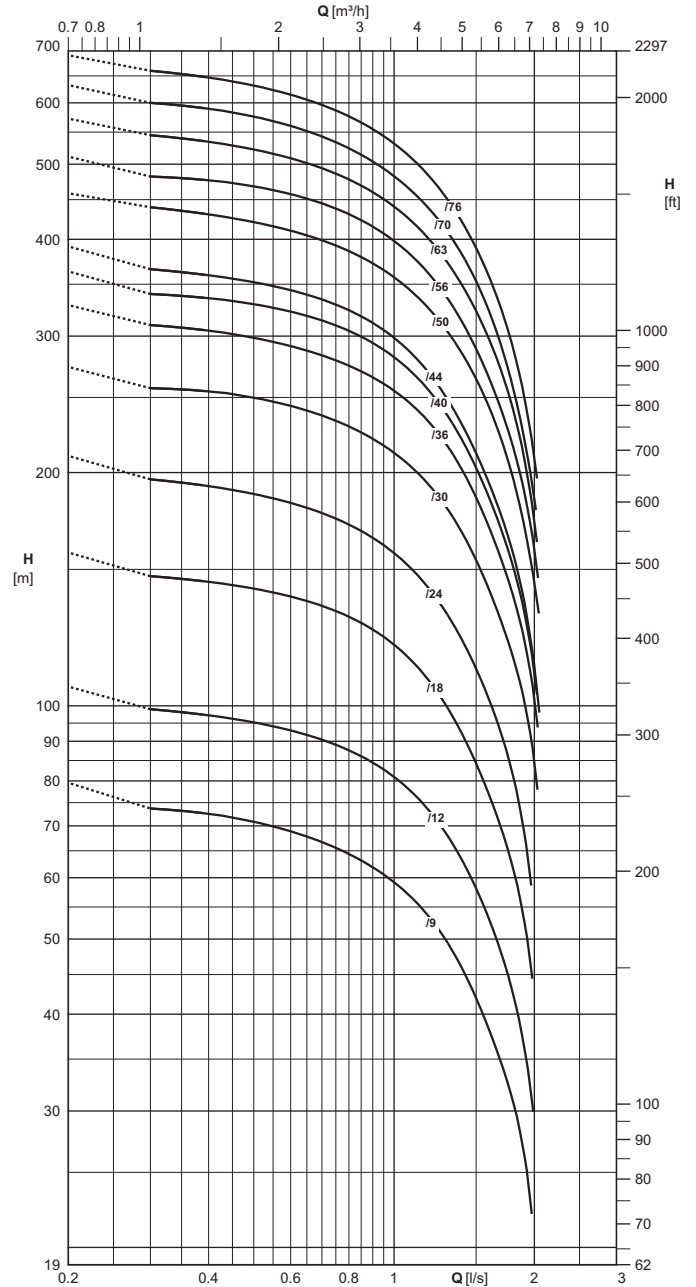

The hydraulic performance characteristics are guaranteed as conforming to standard UNI/ISO 9906 Grade 3B.  
The hydraulic characteristics of units coupled to MAC 6...-2B 6" motors are guaranteed as conforming to standard UNI/ISO 9906 Grade 2B.

Les caractéristiques hydrauliques de fonctionnement sont garanties conformes à la norme UNI/ISO 9906 Niveau 3B.  
Pour les groupes accouplés à des moteurs 6" MAC 6...-2B les caractéristiques hydrauliques sont garanties conformes à la norme UNI/ISO 9906 Niveau 2B.

Le caratteristiche idrauliche di funzionamento vengono garantite secondo la norma UNI/ISO 9906 Grado 3B.  
Per i gruppi accoppiati a motori 6" MAC 6...-2B le caratteristiche idrauliche vengono garantite secondo la norma UNI/ISO 9906 Grado 2B.

Electric pump type Electropompe type Elettropompa tipo	Motor power Puisse. moteur Potenza motore		Horizontal installation Installation horizontale Installazione orizzontale	Check valve $\varnothing$ Clapet de retenue $\varnothing$ Valvola di ritegno $\varnothing$	Capacity Debit Portata														
	[kW]	[HP]			[l/s]	0	0,3	0,4	0,5	0,6	0,7	0,8	0,9	1	1,2	1,4	1,6	1,8	2
					[l/min]	0	18	24	30	36	42	48	54	60	72	84	96	108	120
					[m <sup>3</sup> /h]	0	1,1	1,4	1,8	2,2	2,5	2,9	3,2	3,6	4,3	5	5,8	6,5	7,2
Head Hauteur Prevalenza																			
E6XD20/9+MCH415	1,1	1,5	■	2 1/2" Gas	[m]	79	74	72	71	69	67	64	62	59	53	46	38	31	-
E6XD20/12+MCH42	1,5	2	■	2 1/2" Gas	[m]	106	99	97	95	93	90	87	84	81	73	63	53	42,5	-
E6XD20/18+MCK43	2,2	3	■	2 1/2" Gas	[m]	158	147	144	141	138	134	130	125	120	107	92	77	62	-
E6XD20/24+MCR44	3	4	■	2 1/2" Gas	[m]	210	196	192	187	183	177	171	165	157	140	121	102	81	-
E6XD20/30+MCR455	4	5,5	■	2 1/2" Gas	[m]	274	257	254	250	244	237	229	221	212	191	167	141	115	84
E6XD20/30+MAC65A	4	5,5	■	2 1/2" Gas	[m]	274	257	254	250	244	237	229	221	212	191	167	141	115	84
E6XDB20/36+MAC67A	5,5	7,5	■	2 1/2" Gas	[m]	329	310	305	298	291	283	275	265	255	231	201	170	139	101
E6XDB20/40+MAC67A	5,5	7,5	■	2 1/2" Gas	[m]	364	340	336	330	322	314	305	294	282	253	220	185	151	110
E6XDB20/44+MAC67A	5,5	7,5	■	2 1/2" Gas	[m]	392	366	359	352	344	334	324	312	298	267	230	193	157	112
E6XDB20/50+MAC610A	7,5	10	■	2 1/2" Gas	[m]	459	440	431	421	410	399	386	372	357	323	285	242	196	144
E6XDB20/56+MAC610A	7,5	10	■	2 1/2" Gas	[m]	511	482	476	468	457	445	431	415	398	358	313	265	216	158
E6XDB20/63+MAC612A	9,2	12,5	○	2 1/2" Gas	[m]	572	545	534	522	509	494	478	460	441	397	349	297	241	172
E6XDB20/70+MAC612A	9,2	12,5	○	2 1/2" Gas	[m]	632	600	589	576	560	543	524	504	482	435	382	322	257	185
E6XDB20/76+MAC615A	11	15	○	2 1/2" Gas	[m]	691	660	647	631	615	596	576	555	531	480	421	357	289	208
NPSH					[m]	-	-	-	1,9	1,9	1,9	1,9	1,9	1,9	2	2	2,1	2,2	-

M.E.I.  $\geq$  0.10

■ Without conical valve

□ On request

○ Please contact our sales organisation

For motor performances specification see page "motor features"

■ Sans soupape du clapet.

□ Sur demande

○ Contacter notre service commercial.

Pour caracteristiques techniques moteurs voir page "Caracteristiques des moteurs"

■ Senza clapet valvola di ritegno

□ Su richiesta

○ Interpellare la sede o la rete di vendita

Per caratteristiche motori vedere pagina caratteristiche motori

Temperature monitoring device for submersed electric motors 4" + 6": see page "Accessories"

Appareillage de contrôle de la température des moteurs électriques immergés 4" + 6": voir page "Accessories"

Apparecchiatura di controllo temperatura motori elettrici sommersi 4" + 6": vedere pagina accessori

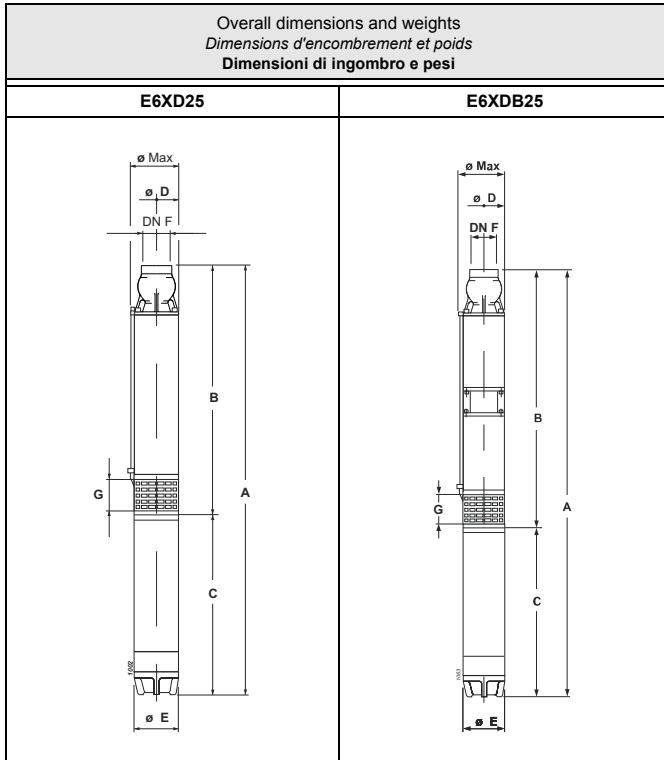

Type Type Tipo	Ø max [mm]	Weight Poids Peso [kg]	[mm]							F
			A	B	C	D	E	G		
E6XD25/7+MCH42	135	22	955	508	447	127	96	100	G2 1/2	
E6XD25/10+MCH43	135	25	1073	598	475	127	96	100	G2 1/2	
E6XD25/13+MCH44	135	29	1203	688	515	127	96	100	G2 1/2	
E6XD25/17+MCR455	135	37,5	1457	867	590	127	96	100	G2 1/2	
E6XD25/17+MAC65A	145	46,5	1432	902	530	141	143	100	G2 1/2	
E6XD25/21+MCR475	135	42,5	1672	987	685	127	96	100	G2 1/2	
E6XD25/21+MAC67A	145	51	1572	1022	550	141	143	100	G2 1/2	
E6XD25/24+MCR475	135	44	1762	1077	685	127	96	100	G2 1/2	
E6XD25/24+MAC67A	145	52,5	1662	1112	550	141	143	100	G2 1/2	
E6XD25/28+MAC610A	145	59,5	1827	1232	595	141	143	100	G2 1/2	
E6XD25/32+MAC610A	145	61,5	1947	1352	595	141	143	100	G2 1/2	
E6XDB25/36+MAC612A	145	67,5	2304	1664	640	141	143	100	G2 1/2	
E6XDB25/40+MAC612A	145	69,5	2424	1784	640	141	143	100	G2 1/2	
E6XDB25/44+MAC615A	145	74	2574	1904	670	141	143	100	G2 1/2	
E6XDB25/50+MAC615A	145	77	2754	2084	670	141	143	100	G2 1/2	
E6XDB25/56+MAC617A	145	83,5	2964	2264	700	141	143	100	G2 1/2	
E6XDB25/63+MAC620A	145	91	3189	2474	715	141	143	100	G2 1/2	

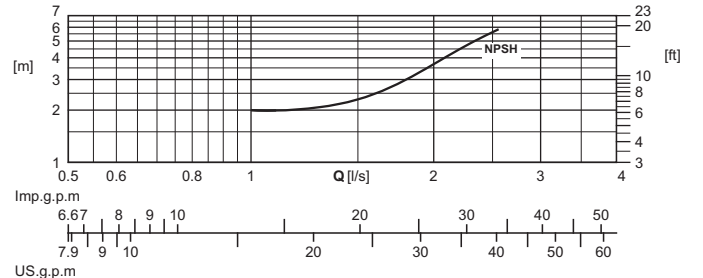
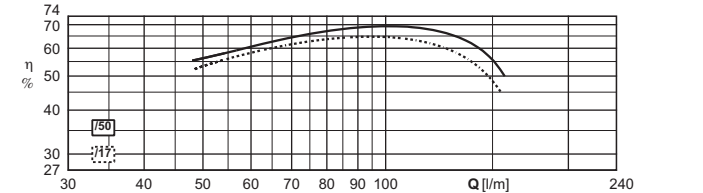
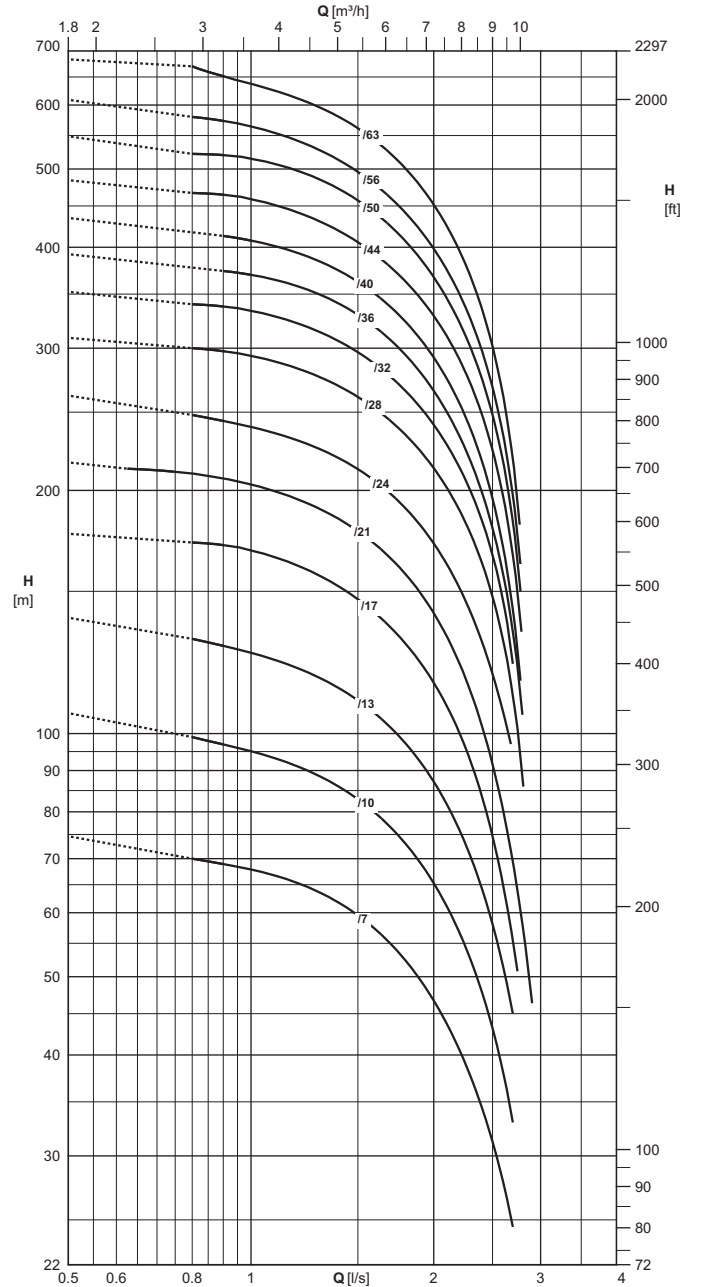

The hydraulic performance characteristics are guaranteed as conforming to standard UNI/ISO 9906 Grade 3B.  
The hydraulic characteristics of units coupled to MAC 6...-2B 6" motors are guaranteed as conforming to standard UNI/ISO 9906 Grade 2B.

Les caractéristiques hydrauliques de fonctionnement sont garanties conformes à la norme UNI/ISO 9906 Niveau 3B.  
Pour les groupes accouplés à des moteurs 6" MAC 6...-2B les caractéristiques hydrauliques sont garanties conformes à la norme UNI/ISO 9906 Niveau 2B.

Le caratteristiche idrauliche di funzionamento vengono garantite secondo la norma UNI/ISO 9906 Grado 3B.  
Per i gruppi accoppiati a motori 6" MAC 6...-2B le caratteristiche idrauliche vengono garantite secondo la norma UNI/ISO 9906 Grado 2B.

Electric pump type Electropompe type Elettropompa tipo	Motor power Puisse. moteur Potenza motore		Horizontal installation Installation horizontale Installazione orizzontale	Check valve $\varnothing$ Clapet de retenue $\varnothing$ Valvola di ritegno $\varnothing$	Capacity Debit Portata														
	[kW]	[HP]			[l/s]	0	0,7	0,8	0,9	1	1,2	1,4	1,6	1,8	2	2,2	2,4	2,6	2,8
					[l/min]	0	42	48	54	60	72	84	96	108	120	132	144	156	168
					[m <sup>3</sup> /h]	0	2,5	2,9	3,2	3,6	4,3	5	5,8	6,5	7,2	7,9	8,6	9,4	10,1
Head Hauteur Prevalenza																			
		[m]	74	-	70	69	68	65	62	57	52	46,5	40,5	34,5	28	-			
E6XD25/7+MCH42	1,5	2	■	2 1/2" Gas	[m]	74	-	70	69	68	65	62	57	52	46,5	40,5	34,5	28	-
E6XD25/10+MCH43	2,2	3	■	2 1/2" Gas	[m]	106	-	99	97	95	91	86	80	73	65	57	48	38	-
E6XD25/13+MCH44	3	4	■	2 1/2" Gas	[m]	139	-	131	128	126	120	114	106	97	87	76	64	52	-
E6XD25/17+MCR455	4	5,5	■	2 1/2" Gas	[m]	177	-	172	171	168	161	152	141	129	115	100	84	65	-
E6XD25/17+MAC65A	4	5,5	■	2 1/2" Gas	[m]	187	-	178	175	172	165	157	148	136	124	110	94	78	-
E6XD25/21+MCR475	5,5	7,5	○	2 1/2" Gas	[m]	216	212	209	207	203	194	184	171	157	141	122	102	80	58
E6XD25/21+MAC67A	5,5	7,5	■	2 1/2" Gas	[m]	231	-	219	215	212	203	193	181	168	152	135	116	95	-
E6XD25/24+MCR475	5,5	7,5	○	2 1/2" Gas	[m]	262	-	248	244	240	230	219	205	190	172	152	130	106	-
E6XD25/24+MAC67A	5,5	7,5	■	2 1/2" Gas	[m]	262	-	248	244	240	230	219	205	190	172	152	130	106	-
E6XD25/28+MAC610A	7,5	10	■	2 1/2" Gas	[m]	309	-	300	297	293	283	269	252	234	213	189	163	131	88
E6XD25/32+MAC610A	7,5	10	■	2 1/2" Gas	[m]	352	-	340	338	334	321	306	287	265	241	214	184	147	-
E6XDB25/36+MAC612A	9,2	12,5	■	2 1/2" Gas	[m]	392	-	-	374	370	357	340	319	294	266	234	199	158	105
E6XDB25/40+MAC612A	9,2	12,5	■	2 1/2" Gas	[m]	435	-	-	413	408	393	374	350	323	292	257	217	170	-
E6XDB25/44+MAC615A	11	15	■	2 1/2" Gas	[m]	484	-	467	464	458	441	418	392	362	329	291	248	197	-
E6XDB25/50+MAC615A	11	15	■	2 1/2" Gas	[m]	549	-	522	520	514	497	472	441	406	367	324	275	217	-
E6XDB25/56+MAC617A	13	17,5	○	2 1/2" Gas	[m]	609	-	580	573	564	541	512	478	440	398	351	298	235	-
E6XDB25/63+MAC620A	15	20	○	2 1/2" Gas	[m]	683	-	670	652	638	610	579	542	500	451	397	336	262	-
NPSH					[m]	-	-	-	-	2	2	2,2	2,6	3,1	3,8	4,5	5,2	-	-

M.E.I.  $\geq 0.10$

■ Without conical valve

□ On request

○ Please contact our sales organisation

For motor performances specification see page "motor features"

■ Sans soupape du clapet.

□ Sur demande

○ Contacter notre service commercial.

Pour caractéristiques techniques moteurs voir page "Caractéristiques des moteurs"

■ Senza clapet valvola di ritegno

□ Su richiesta

○ Interpellare la sede o la rete di vendita

Per caratteristiche motori vedere pagina caratteristiche motori

Temperature monitoring device for submersed electric motors 4" + 6": see page "Accessories"

Appareillage de contrôle de la température des moteurs électriques immergés 4" + 6": voir page "Accessories"

Apparecchiatura di controllo temperatura motori elettrici sommersi 4" + 6": vedere pagina accessori

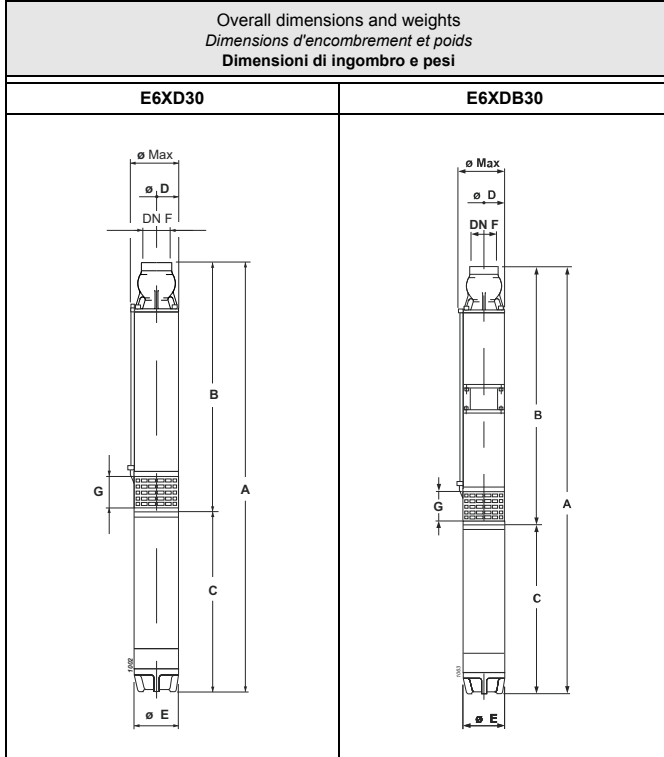

Type Type Tipo	Ø max [mm]	Weight Poids Peso [kg]	[mm]							F
			A	B	C	D	E	G		
E6XD30/5+MCH42	135	21	920	473	447	127	96	100	G2 1/2	
E6XD30/8+MCH43	135	24,5	1053	578	475	127	96	100	G2 1/2	
E6XD30/10+MCH44	135	28,5	1163	648	515	127	96	100	G2 1/2	
E6XD30/13+MCH455	135	34	1352	812	540	127	96	100	G2 1/2	
E6XD30/13+MAC65A	145	46	1377	847	530	141	143	100	G2 1/2	
E6XD30/16+MCR475	135	42	1602	917	685	127	96	100	G2 1/2	
E6XD30/16+MAC67A	145	50,5	1502	952	550	141	143	100	G2 1/2	
E6XD30/18+MCR475	135	43,5	1672	987	685	127	96	100	G2 1/2	
E6XD30/18+MAC67A	145	52	1572	1022	550	141	143	100	G2 1/2	
E6XD30/21+MCR410	135	49,5	1862	1092	770	127	96	100	G2 1/2	
E6XD30/21+MAC610A	145	59	1722	1127	595	141	143	100	G2 1/2	
E6XD30/24+MCR410	135	51,5	1967	1197	770	127	96	100	G2 1/2	
E6XD30/24+MAC610A	145	61	1827	1232	595	141	143	100	G2 1/2	
E6XD30/28+MAC612A	145	67,5	2012	1372	640	141	143	100	G2 1/2	
E6XD30/31+MAC612A	145	69,5	2117	1477	640	141	143	100	G2 1/2	
E6XD30/36+MAC615A	145	75,5	2322	1652	670	141	143	100	G2 1/2	
E6XDB30/42+MAC617A	145	83	2754	2054	700	141	143	100	G2 1/2	
E6XDB30/47+MAC620A	145	90,5	2944	2229	715	141	143	100	G2 1/2	
E6XDB30/52+MAC625A	145	98	3154	2404	750	141	143	100	G2 1/2	
E6XDB30/56+MAC625A	145	101	3294	2544	750	141	143	100	G2 1/2	
E6XDB30/60+MAC625A	145	103,5	3434	2684	750	141	143	100	G2 1/2	
E6XDB30/65+MAC630A	145	110,5	3649	2859	790	141	143	100	G2 1/2	

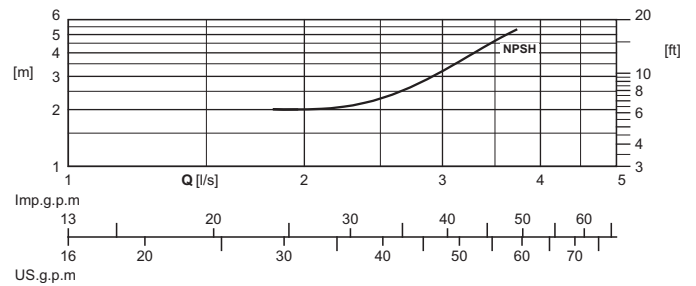
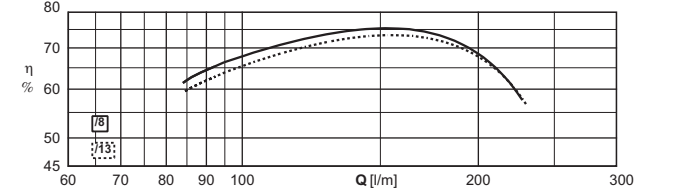
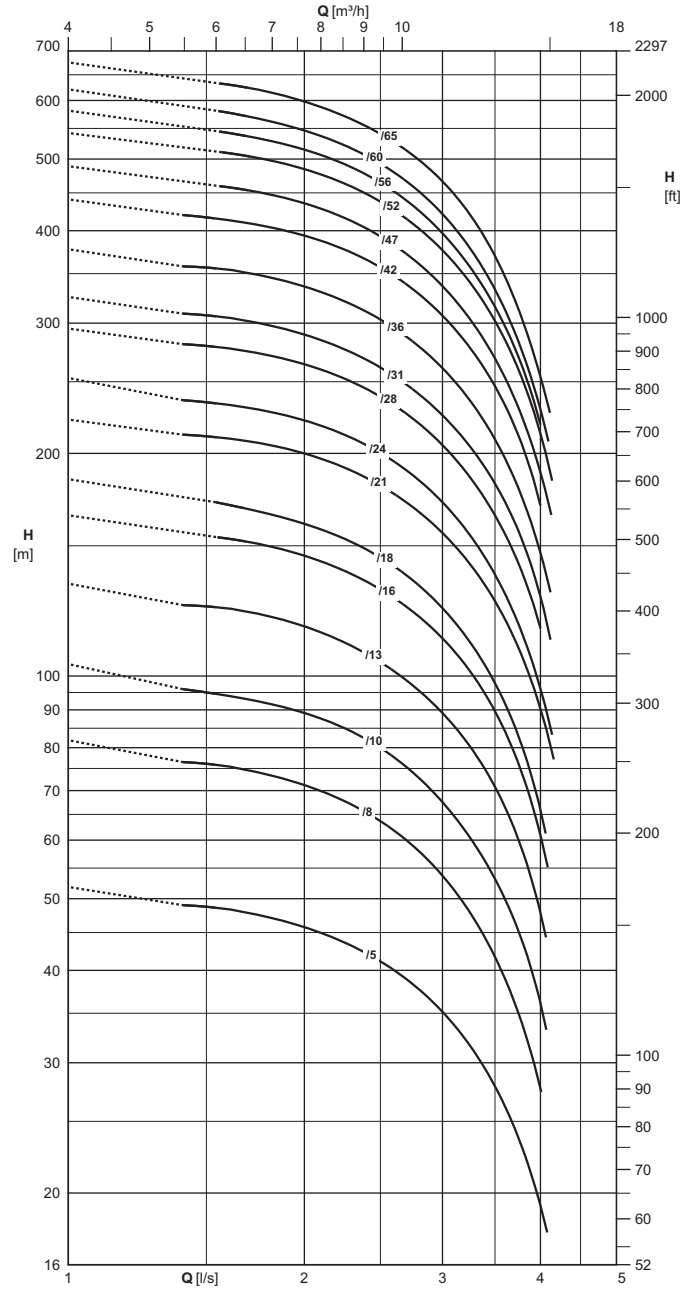

The hydraulic performance characteristics are guaranteed as conforming to standard UNI/ISO 9906 Grade 3B.  
The hydraulic characteristics of units coupled to MAC 6...-2B 6" motors are guaranteed as conforming to standard UNI/ISO 9906 Grade 2B.

Les caractéristiques hydrauliques de fonctionnement sont garanties conformes à la norme UNI/ISO 9906 Niveau 3B.  
Pour les groupes accouplés à des moteurs 6" MAC 6...-2B les caractéristiques hydrauliques sont garanties conformes à la norme UNI/ISO 9906 Niveau 2B.

Le caratteristiche idrauliche di funzionamento vengono garantite secondo la norma UNI/ISO 9906 Grado 3B.  
Per i gruppi accoppiati a motori 6" MAC 6...-2B le caratteristiche idrauliche vengono garantite secondo la norma UNI/ISO 9906 Grado 2B.

Electric pump type Electropompe type Elettropompa tipo	Motor power Puis. moteur Potenza motore		Horizontal installation Installation horizontale Installazione orizzontale	Check valve $\varnothing$ Clapet de retenue $\varnothing$ Valvola di ritegno $\varnothing$	Capacity Debit Portata													
	[kW]	[HP]			[l/s]	0	1,4	1,6	1,8	2	2,2	2,4	2,6	2,8	3	3,5	4	
					[l/min]	0	84	96	108	120	132	144	156	168	180	210	240	
					[m <sup>3</sup> /h]	0	5	5,8	6,5	7,2	7,9	8,6	9,4	10,1	10,8	12,6	14,4	
					Head Hauteur Prevalenza													
					[m]	52	49	48,5	47	45,5	44	42	40	37,5	35	28	19	
E6XD30/5+MCH42	1,5	2	■	2 1/2" Gas	[m]	52	49	48,5	47	45,5	44	42	40	37,5	35	28	19	
E6XD30/8+MCH43	2,2	3	■	2 1/2" Gas	[m]	82	76	75	73	71	68	65	62	58	54	41,5	27,5	
E6XD30/10+MCH44	3	4	■	2 1/2" Gas	[m]	104	96	94	92	89	86	82	78	73	67	53	36	
E6XD30/13+MCH455	4	5,5	■	2 1/2" Gas	[m]	133	125	123	120	117	112	107	101	95	89	71	48	
E6XD30/13+MAC65A	4	5,5	■	2 1/2" Gas	[m]	137	131	129	126	123	118	114	108	102	95	77	55	
E6XD30/16+MCR475	5,5	7,5	○	2 1/2" Gas	[m]	165	-	153	150	145	140	134	127	120	112	89	61	
E6XD30/16+MAC67A	5,5	7,5	■	2 1/2" Gas	[m]	168	160	158	154	150	145	139	132	125	117	94	67	
E6XD30/18+MCR475	5,5	7,5	○	2 1/2" Gas	[m]	184	-	170	166	160	155	148	141	132	123	98	66	
E6XD30/18+MAC67A	5,5	7,5	■	2 1/2" Gas	[m]	189	179	176	173	168	162	156	148	140	130	104	73	
E6XD30/21+MCR410	7,5	10	○	2 1/2" Gas	[m]	222	212	209	205	200	193	185	176	166	156	126	90	
E6XD30/21+MAC610A	7,5	10	■	2 1/2" Gas	[m]	222	212	209	205	200	193	185	176	166	156	126	90	
E6XD30/24+MCR410	7,5	10	○	2 1/2" Gas	[m]	253	236	232	228	221	214	205	195	184	172	137	96	
E6XD30/24+MAC610A	7,5	10	■	2 1/2" Gas	[m]	253	236	232	228	221	214	205	195	184	172	137	96	
E6XD30/28+MAC612A	9,2	12,5	■	2 1/2" Gas	[m]	295	281	277	271	264	255	244	232	219	205	165	116	
E6XD30/31+MAC612A	9,2	12,5	■	2 1/2" Gas	[m]	325	309	305	298	289	279	268	254	240	225	182	128	
E6XD30/36+MAC615A	11	15	■	2 1/2" Gas	[m]	378	358	354	346	336	324	311	295	279	261	209	147	
E6XDB30/42+MAC617A	13	17,5	■	2 1/2" Gas	[m]	441	420	413	405	394	381	365	348	328	307	246	170	
E6XDB30/47+MAC620A	15	20	■	2 1/2" Gas	[m]	489	-	458	448	435	420	403	383	361	337	269	188	
E6XDB30/52+MAC625A	18,5	25	■	2 1/2" Gas	[m]	542	-	509	498	484	468	448	427	402	376	302	212	
E6XDB30/56+MAC625A	18,5	25	○	2 1/2" Gas	[m]	581	-	542	530	515	497	476	452	426	397	316	219	
E6XDB30/60+MAC625A	18,5	25	○	2 1/2" Gas	[m]	621	-	577	563	546	527	505	480	452	421	333	229	
E6XDB30/65+MAC630A	22	30	○	2 1/2" Gas	[m]	675	-	630	616	598	577	553	527	498	466	370	254	
NPSH						[m]	-	-	-	-	2	2,1	2,2	2,4	2,8	3,2	4,6	-

M.E.I.  $\geq 0.10$

■ Without conical valve

□ On request

○ Please contact our sales organisation

For motor performances specification see page "motor features"

Temperature monitoring device for submersed electric motors 4" + 6": see page "Accessories"

■ Sans soupape du clapet.

□ Sur demande

○ Contacter notre service commercial.

Pour caracteristiques techniques moteurs voir page "Caracteristiques des moteurs"

Appareillage de contrôle de la température des moteurs électriques immergés 4" + 6": voir page "Accessories"

■ Senza clapet valvola di ritegno

□ Su richiesta

○ Interpellare la sede o la rete di vendita

Per caratteristiche motori vedere pagina caratteristiche motori

Apparecchiatura di controllo temperatura motori elettrici sommersi 4" + 6": vedere pagina accessori

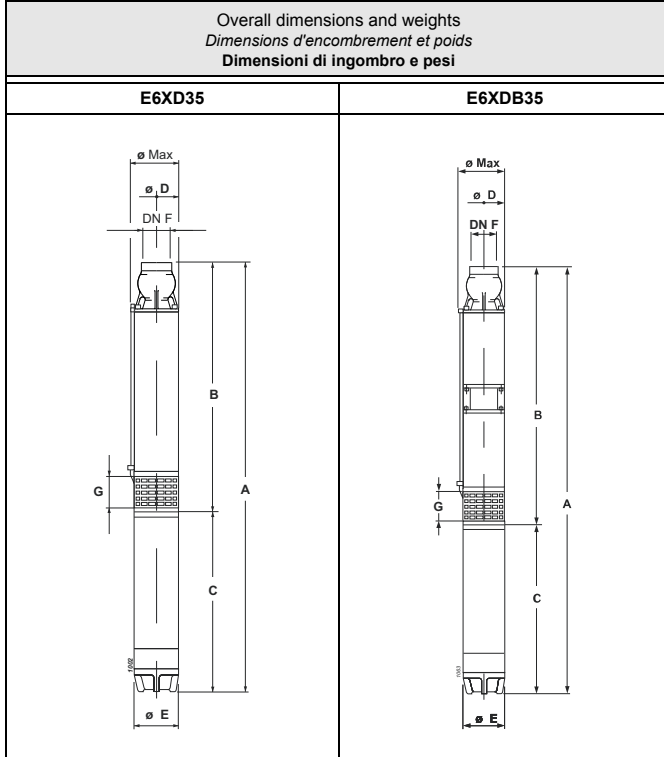

Type Type Tipo	Ø max [mm]	Weight Poids Peso [kg]	[mm]							F
			A	B	C	D	E	G		
E6XD35/3+MCH415	135	19	823	403	420	127	96	100	G2 1/2	
E6XD35/4+MCH42	135	20,5	885	438	447	127	96	100	G2 1/2	
E6XD35/6+MCH43	135	23,5	983	508	475	127	96	100	G2 1/2	
E6XD35/7+MCH44	135	26,5	1058	543	515	127	96	100	G2 1/2	
E6XD35/9+MCH455	135	31,5	1153	613	540	127	96	100	G2 1/2	
E6XD35/9+MAC65A	145	43,5	1178	648	530	141	143	100	G2 1/2	
E6XD35/11+MCR475	135	40	1368	683	685	127	96	100	G2 1/2	
E6XD35/11+MAC67A	145	47,5	1268	718	550	141	143	100	G2 1/2	
E6XD35/13+MCR475	135	40	1497	812	685	127	96	100	G2 1/2	
E6XD35/13+MAC67A	145	48,5	1397	847	550	141	143	100	G2 1/2	
E6XD35/15+MCR410	135	45,5	1652	882	770	127	96	100	G2 1/2	
E6XD35/15+MAC610A	145	55	1512	917	595	141	143	100	G2 1/2	
E6XD35/18+MCR410	135	47	1757	987	770	127	96	100	G2 1/2	
E6XD35/18+MAC610A	145	57	1617	1022	595	141	143	100	G2 1/2	
E6XD35/22+MAC612A	145	63,5	1802	1162	640	141	143	100	G2 1/2	
E6XD35/26+MAC615A	145	69	1972	1302	670	141	143	100	G2 1/2	
E6XD35/31+MAC617A	145	75,5	2177	1477	700	141	143	100	G2 1/2	
E6XD35/35+MAC620A	145	82,5	2332	1617	715	141	143	100	G2 1/2	
E6XDB35/40+MAC625A	145	90	2734	1984	750	141	143	100	G2 1/2	
E6XDB35/44+MAC625A	145	42	2874	2124	750	141	143	100	G2 1/2	
E6XDB35/48+MAC630A	145	99,5	3054	2264	790	141	143	100	G2 1/2	
E6XDB35/52+MAC630A	145	102	3194	2404	790	141	143	100	G2 1/2	
E6XDB35/56+MAC630A	145	105	3334	2544	790	141	143	100	G2 1/2	
E6XDB35/60+MAC635A	145	117,5	3559	2684	875	141	143	100	G2 1/2	
E6XDB35/65+MAC635A	145	121	3734	2859	875	141	143	100	G2 1/2	

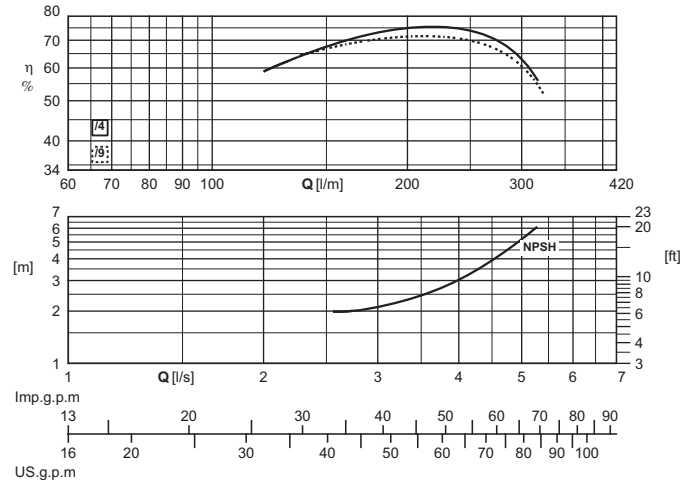
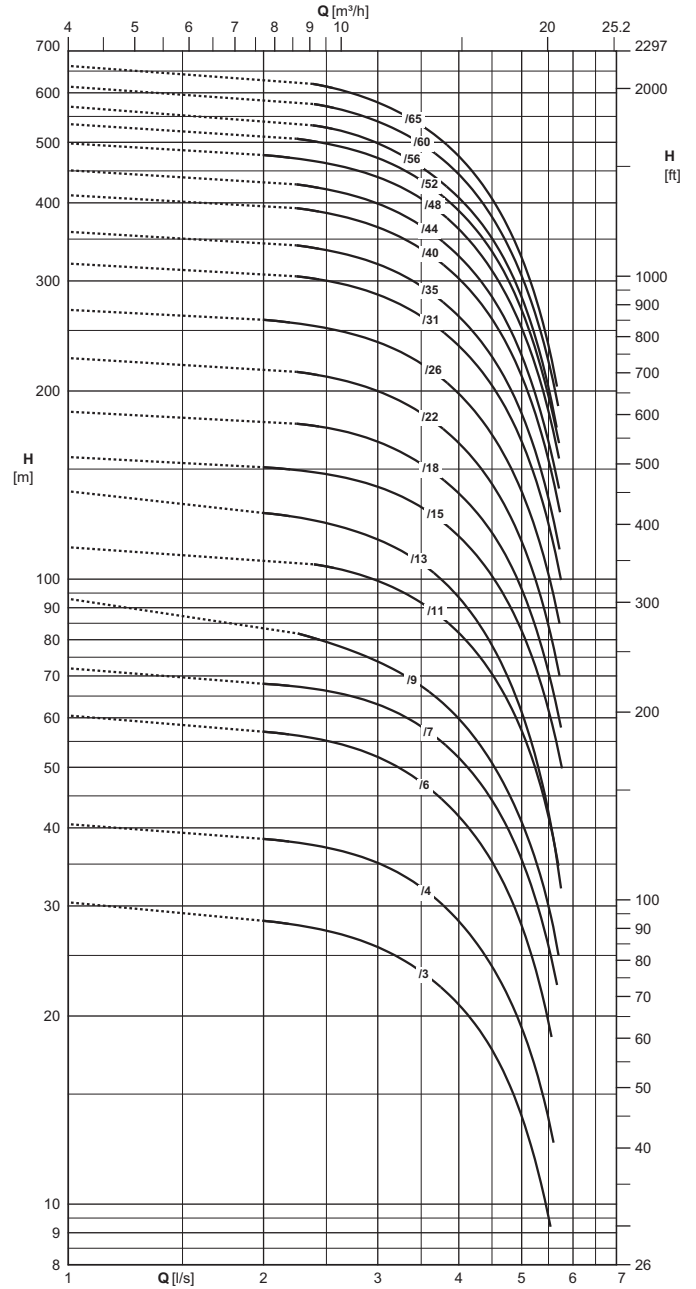

The hydraulic performance characteristics are guaranteed as conforming to standard UNI/ISO 9906 Grade 3B. The hydraulic characteristics of units coupled to MAC 6...-2B 6" motors are guaranteed as conforming to standard UNI/ISO 9906 Grade 2B.

Les caractéristiques hydrauliques de fonctionnement sont garanties conformes à la norme UNI/ISO 9906 Niveau 3B. Pour les groupes accouplés à des moteurs 6" MAC 6...-2B les caractéristiques hydrauliques de fonctionnement sont garanties conformes à la norme UNI/ISO 9906 Niveau 2B.

Le caratteristiche idrauliche di funzionamento vengono garantite secondo la norma UNI/ISO 9906 Grado 3B. Per i gruppi accoppiati a motori 6" MAC 6...-2B le caratteristiche idrauliche vengono garantite secondo la norma UNI/ISO 9906 Grado 2B.

Electric pump type Electropompe type Elettropompa tipo	Motor power Puisse. moteur Potenza motore		Horizontal installation Installation horizontale Installazione orizzontale	Check valve $\varnothing$ Clapet de retenue $\varnothing$ Valvola di ritegno $\varnothing$	Capacity Debit Portata												
	[kW]	[HP]			[l/s]	0	2	2,2	2,4	2,6	2,8	3	3,5	4	4,5	5	5,5
					[l/min]	0	120	132	144	156	168	180	210	240	270	300	330
					[m <sup>3</sup> /h]	0	7,2	7,9	8,6	9,4	10,1	10,8	12,6	14,4	16,2	18	19,8
					Head Hauteur Prevalenza												
E6XD35/3+MCH415	1,1	1,5	■	2 1/2" Gas	[m]	30,5	28,5	28	27,5	27	26,5	26	23,5	21	17,5	14	9,5
E6XD35/4+MCH42	1,5	2	■	2 1/2" Gas	[m]	40,5	38,5	38	37,5	37	36	35	32	28,5	24	19	13,5
E6XD35/6+MCH43	2,2	3	■	2 1/2" Gas	[m]	60	57	56	56	55	53	52	47,5	41,5	35,5	28	19,5
E6XD35/7+MCH44	3	4	■	2 1/2" Gas	[m]	72	68	67	67	66	64	63	58	52	44,5	35,5	26
E6XD35/9+MCH455	4	5,5	■	2 1/2" Gas	[m]	93	-	-	80	78	76	74	67	60	51	41	30
E6XD35/9+MAC65A	4	5,5	■	2 1/2" Gas	[m]	94	90	89	88	87	85	84	77	70	60	49	36,5
E6XD35/11+MCR475	5,5	7,5	○	2 1/2" Gas	[m]	112	-	-	105	104	102	99	91	82	70	57	41,5
E6XD35/11+MAC67A	5,5	7,5	■	2 1/2" Gas	[m]	115	110	109	108	106	104	102	95	85	74	62	49
E6XD35/13+MCR475	5,5	7,5	○	2 1/2" Gas	[m]	138	127	126	124	122	119	116	106	93	78	61	42,5
E6XD35/13+MAC67A	5,5	7,5	■	2 1/2" Gas	[m]	135	128	127	126	124	122	119	110	98	84	68	50
E6XD35/15+MCR410	7,5	10	○	2 1/2" Gas	[m]	157	151	150	148	146	143	140	130	117	101	83	62
E6XD35/15+MAC610A	7,5	10	■	2 1/2" Gas	[m]	157	151	150	148	146	143	140	130	117	101	83	62
E6XD35/18+MCR410	7,5	10	○	2 1/2" Gas	[m]	185	-	-	176	173	170	166	153	137	118	96	71
E6XD35/18+MAC610A	7,5	10	■	2 1/2" Gas	[m]	185	-	-	176	173	170	166	153	137	118	96	71
E6XD35/22+MAC612A	9,2	12,5	■	2 1/2" Gas	[m]	226	-	-	212	209	205	200	184	165	142	115	84
E6XD35/26+MAC615A	11	15	■	2 1/2" Gas	[m]	270	260	257	254	250	245	239	221	198	170	138	102
E6XD35/31+MAC617A	13	17,5	■	2 1/2" Gas	[m]	320	-	-	302	298	292	285	263	236	204	166	122
E6XD35/35+MAC620A	15	20	■	2 1/2" Gas	[m]	359	-	-	339	333	327	319	294	263	227	184	134
E6XDB35/40+MAC625A	18,5	25	■	2 1/2" Gas	[m]	411	-	-	388	382	374	366	338	303	261	211	155
E6XDB35/44+MAC625A	18,5	25	■	2 1/2" Gas	[m]	451	-	-	424	417	409	399	368	329	283	228	166
E6XDB35/48+MAC630A	22	30	■	2 1/2" Gas	[m]	498	477	472	466	459	450	440	406	363	312	252	185
E6XDB35/52+MAC630A	22	30	■	2 1/2" Gas	[m]	535	-	-	501	493	483	472	435	388	334	270	196
E6XDB35/56+MAC630A	22	30	○	2 1/2" Gas	[m]	570	-	-	531	523	512	498	456	407	351	283	202
E6XDB35/60+MAC635A	26	35	○	2 1/2" Gas	[m]	614	-	-	575	566	554	540	497	444	380	305	223
E6XDB35/65+MAC635A	26	35	○	2 1/2" Gas	[m]	662	-	-	619	608	594	579	532	475	406	327	236
NPSH					[m]	-	-	-	-	-	1,9	2	2,8	3	3,9	7	-

M.E.I.  $\geq 0,10$

■ Without conical valve

○ On request

○ Please contact our sales organisation

For motor performances specification see page "motor features"

Temperature monitoring device for submersed electric motors 4" + 6": see page "Accessories"

■ Sans soupape du clapet.

○ Sur demande

○ Contacter notre service commercial.

Pour caracteristiques techniques moteurs voir page "Caracteristiques des moteurs"

Appareillage de contrôle de la température des moteurs électriques immergés 4" + 6": voir page "Accessories"

■ Senza clapet valvola di ritegno

○ Su richiesta

○ Interpellare la sede o la rete di vendita

Per caratteristiche motori vedere pagina caratteristiche motori

Apparecchiatura di controllo temperatura motori elettrici sommersi 4" + 6": vedere pagina accessori



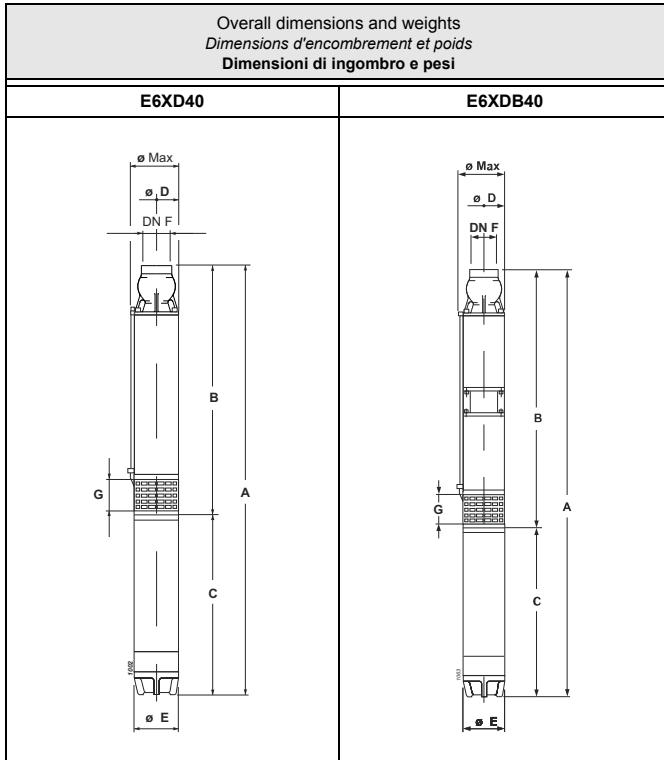

Type Type Tipo	Ø max [mm]	Weight Poids Peso [kg]	[mm]							F
			A	B	C	D	E	G		
E6XD40/3+MCH42	135	21	865	418	447	127	96	100	G2 1/2	
E6XD40/4+MCH43	135	23	933	458	475	127	96	100	G2 1/2	
E6XD40/6+MCH44	135	27	1053	538	515	127	96	100	G2 1/2	
E6XD40/8+MCH455	135	32	1158	618	540	127	96	100	G2 1/2	
E6XD40/8+MAC65A	145	44	1183	653	530	141	143	100	G2 1/2	
E6XD40/10+MCR475	135	39,5	1383	698	685	127	96	100	G2 1/2	
E6XD40/10+MAC67A	145	48	1283	733	550	141	143	100	G2 1/2	
E6XD40/13+MCR410	135	45,5	1647	877	770	127	96	100	G2 1/2	
E6XD40/13+MAC610A	145	55	1507	912	595	141	143	100	G2 1/2	
E6XD40/16+MAC612A	145	60,5	1672	1032	640	141	143	100	G2 1/2	
E6XD40/20+MAC615A	145	66	1862	1192	670	141	143	100	G2 1/2	
E6XD40/23+MAC617A	145	71,5	2012	1312	700	141	143	100	G2 1/2	
E6XD40/26+MAC620A	145	77,5	2147	1432	715	141	143	100	G2 1/2	
E6XD40/30+MAC625A	145	84,5	2342	1592	750	141	143	100	G2 1/2	
E6XD40/33+MAC625A	145	86,5	2462	1712	750	141	143	100	G2 1/2	
E6XDB40/38+MAC630A	145	93,5	2894	2104	790	141	143	100	G2 1/2	
E6XDB40/42+MAC630A	145	96,5	3054	2264	790	141	143	100	G2 1/2	
E6XDB40/44+MAC635A	145	108	3219	2344	875	141	143	100	G2 1/2	
E6XDB40/48+MAC635A	145	110,5	3379	2504	875	141	143	100	G2 1/2	
E6XDB40/51+MAC640A	145	128,5	3649	2624	1025	141	143	100	G2 1/2	
E6XDB40/55+MAC640A	145	131,2	3809	2784	1025	141	143	100	G2 1/2	
E6XDB40/60+MAC650B	145	160	4211	2984	1227	141	143	100	G2 1/2	

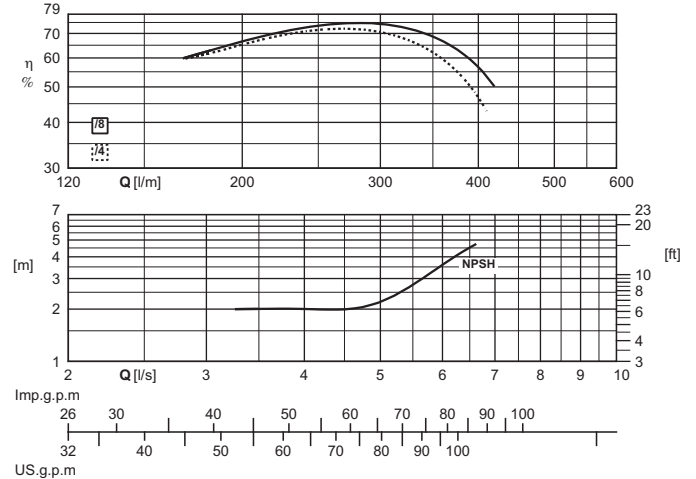
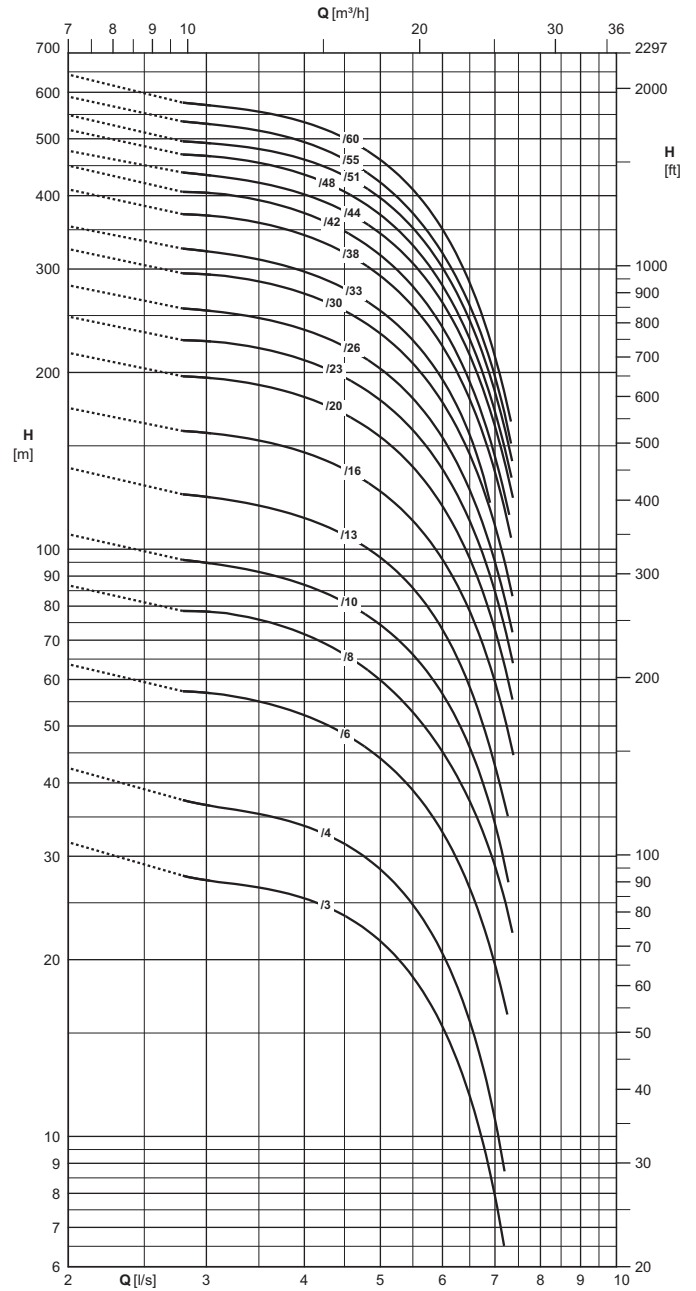

The hydraulic performance characteristics are guaranteed as conforming to standard UNI/ISO 9906 Grade 3B.  
The hydraulic characteristics of units coupled to MAC 6...-2B 6" motors are guaranteed as conforming to standard UNI/ISO 9906 Grade 2B.

Les caractéristiques hydrauliques de fonctionnement sont garanties conformes à la norme UNI/ISO 9906 Niveau 3B.  
Pour les groupes accouplés à des moteurs 6" MAC 6...-2B les caractéristiques hydrauliques sont garanties conformes à la norme UNI/ISO 9906 Niveau 2B.

Le caratteristiche idrauliche di funzionamento vengono garantite secondo la norma UNI/ISO 9906 Grado 3B.  
Per i gruppi accoppiati a motori 6" MAC 6...-2B le caratteristiche idrauliche vengono garantite secondo la norma UNI/ISO 9906 Grado 2B.

Electric pump type Electropompe type Elettropompa tipo	Motor power Puis. moteur Potenza motore		Horizontal installation Installation horizontale Installazione orizzontale	Check valve $\varnothing$ Clapet de retenue $\varnothing$ Valvola di ritegno $\varnothing$	Capacity Debit Portata														
	[kW]	[HP]			[l/s]	0	2,8	3	3,5	4	4,5	5	5,5	6	6,5	7	7,5	8	8,5
					[l/min]	0	168	180	210	240	270	300	330	360	390	420	450	480	510
					[m <sup>3</sup> /h]	0	10,1	10,8	12,6	14,4	16,2	18	19,8	21,6	23,4	25,2	27	28,8	30,6
Head Hauteur Prevalenza																			
E6XD40/3+MCH42	1,5	2	■	2 1/2" Gas	[m]	31,5	28	27,5	26,5	25,5	23,5	21,5	18,5	15,5	11,5	7,9	-	-	-
E6XD40/4+MCH43	2,2	3	■	2 1/2" Gas	[m]	42,5	37,5	36,5	35,5	34	31,5	28,5	25	20,5	15,5	10,5	-	-	-
E6XD40/6+MCH44	3	4	■	2 1/2" Gas	[m]	64	57	57	55	52	48,5	44	39	33	26,5	19,5	-	-	-
E6XD40/8+MCH455	4	5,5	■	2 1/2" Gas	[m]	86	74	73	71	68	63	57	49	41	31	-	-	-	-
E6XD40/8+MAC65A	4	5,5	■	2 1/2" Gas	[m]	87	78	78	76	72	66	60	53	45	37	29	-	-	-
E6XD40/10+MCR475	5,5	7,5	○	2 1/2" Gas	[m]	106	96	95	91	87	81	74	66	57	46	34	-	-	-
E6XD40/10+MAC67A	5,5	7,5	■	2 1/2" Gas	[m]	108	98	97	95	90	84	77	69	59	48	36,5	-	-	-
E6XD40/13+MCR410	7,5	10	○	2 1/2" Gas	[m]	137	124	123	119	113	106	97	86	73	58	43	-	-	-
E6XD40/13+MAC610A	7,5	10	■	2 1/2" Gas	[m]	141	130	129	125	119	111	102	91	78	64	49	-	-	-
E6XD40/16+MAC612A	9,2	12,5	■	2 1/2" Gas	[m]	174	159	158	153	146	137	125	112	96	78	59	-	-	-
E6XD40/20+MAC615A	11	15	■	2 1/2" Gas	[m]	216	197	196	190	181	170	155	138	118	96	73	-	-	-
E6XD40/23+MAC617A	13	17,5	■	2 1/2" Gas	[m]	249	227	226	220	210	196	179	159	137	112	85	-	-	-
E6XD40/26+MAC620A	15	20	■	2 1/2" Gas	[m]	281	257	255	247	236	221	203	180	155	126	95	-	-	-
E6XD40/30+MAC625A	18,5	25	■	2 1/2" Gas	[m]	324	295	294	286	272	255	233	207	178	145	110	-	-	-
E6XD40/33+MAC625A	18,5	25	■	2 1/2" Gas	[m]	355	325	322	311	297	278	254	227	194	156	-	-	-	-
E6XDB40/38+MAC630A	22	30	■	2 1/2" Gas	[m]	410	372	370	360	343	320	292	259	221	180	135	-	-	-
E6XDB40/42+MAC630A	22	30	■	2 1/2" Gas	[m]	450	406	404	393	373	348	317	280	238	193	144	-	-	-
E6XDB40/44+MAC635A	26	35	○	2 1/2" Gas	[m]	477	438	434	421	402	377	345	307	263	214	162	-	-	-
E6XDB40/48+MAC635A	26	35	○	2 1/2" Gas	[m]	518	470	467	455	434	406	371	329	281	228	172	-	-	-
E6XDB40/51+MAC640A	30	40	○	2 1/2" Gas	[m]	549	495	492	480	461	433	396	352	301	245	185	-	-	-
E6XDB40/55+MAC640A	30	40	○	2 1/2" Gas	[m]	590	535	530	516	493	461	421	373	319	260	197	-	-	-
E6XDB40/60+MAC650B	37	50	○	2 1/2" Gas	[m]	643	576	571	556	533	501	460	410	350	284	213	-	-	-
NPSH					[m]	-	-	-	-	-	2,8	2,9	3,1	3,5	4,2	4,8	5,6	-	-

M.E.I.  $\geq$  0.10

■ Without conical valve

○ On request

○ Please contact our sales organisation

For motor performances specification see page "motor features"

Temperature monitoring device for submersed electric motors 4" + 6": see page "Accessories"

■ Sans soupape du clapet.

○ Sur demande

○ Contacter notre service commercial.

Pour caracteristiques techniques moteurs voir page "Caracteristiques des moteurs"

Appareillage de contrôle de la température des moteurs électriques immergés 4" + 6": voir page "Accessories"

■ Senza clapet valvola di ritegno

○ Su richiesta

○ Interpellare la sede o la rete di vendita

Per caratteristiche motori vedere pagina caratteristiche motori

Apprecchiatura di controllo temperatura motori elettrici sommersi 4" + 6": vedere pagina accessori

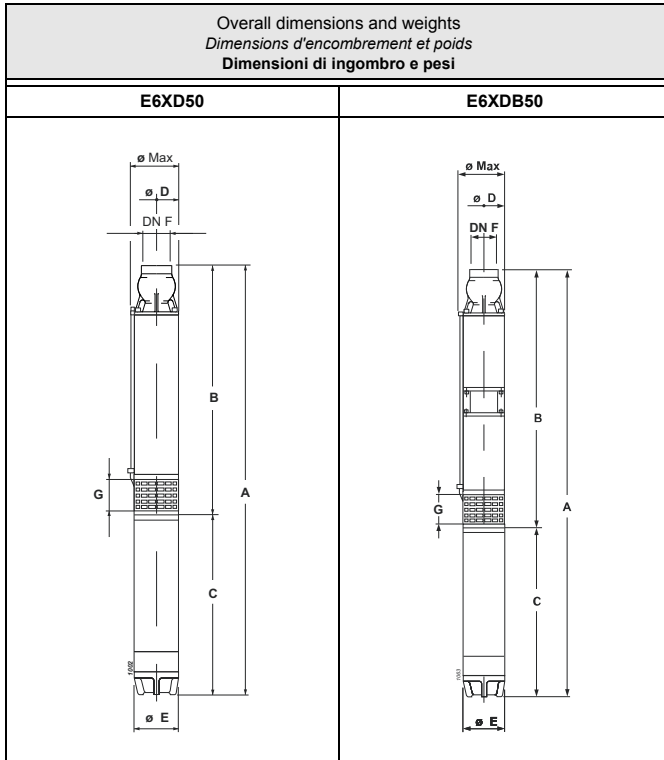

Type Type Tipo	Ø max [mm]	Weight Poids Peso [kg]	[mm]							F
			A	B	C	D	E	G		
E6XD50/3+MCH43	135	20,5	923	448	475	127	96	100	G2 1/2	
E6XD50/4+MCH44	135	24	1013	498	515	127	96	100	G2 1/2	
E6XD50/5+MCH455	135	28	1088	548	540	127	96	100	G2 1/2	
E6XD50/5+MAC65A	145	40,5	1113	583	530	141	143	100	G2 1/2	
E6XD50/7+MCR475	135	36	1333	648	685	127	96	100	G2 1/2	
E6XD50/7+MAC67A	145	44,5	1233	683	550	141	143	100	G2 1/2	
E6XD50/10+MCR410	135	42,5	1627	857	770	127	96	100	G2 1/2	
E6XD50/10+MAC610A	145	52	1487	892	595	141	143	100	G2 1/2	
E6XD50/12+MAC612A	145	57,5	1632	992	640	141	143	100	G2 1/2	
E6XD50/15+MAC615A	145	62,5	1812	1142	670	141	143	100	G2 1/2	
E6XD50/17+MAC617A	145	67,5	1942	1242	700	141	143	100	G2 1/2	
E6XD50/20+MAC620A	145	74,5	2107	1392	715	141	143	100	G2 1/2	
E6XD50/25+MAC625A	145	83	2392	1642	750	141	143	100	G2 1/2	
E6XDB50/30+MAC630A	145	91	2874	2084	790	141	143	100	G2 1/2	
E6XDB50/35+MAC635A	145	105,5	3209	2334	875	141	143	100	G2 1/2	
E6XDB50/40+MAC640A	145	125	3609	2584	1025	141	143	100	G2 1/2	
E6XDB50/45+MAC650B	145	155	4061	2834	1227	141	143	100	G2 1/2	
E6XDB50/48+MAC650B	145	157,5	4211	2984	1227	141	143	100	G2 1/2	

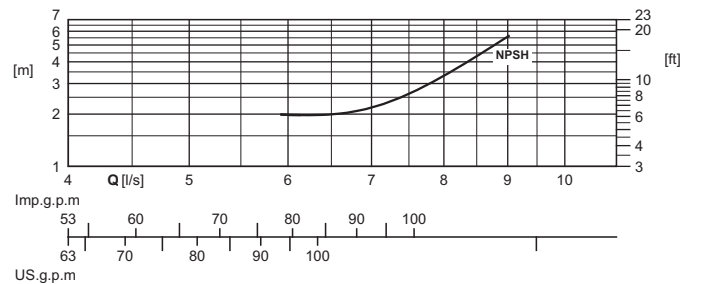
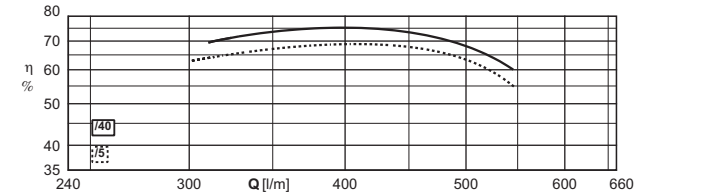
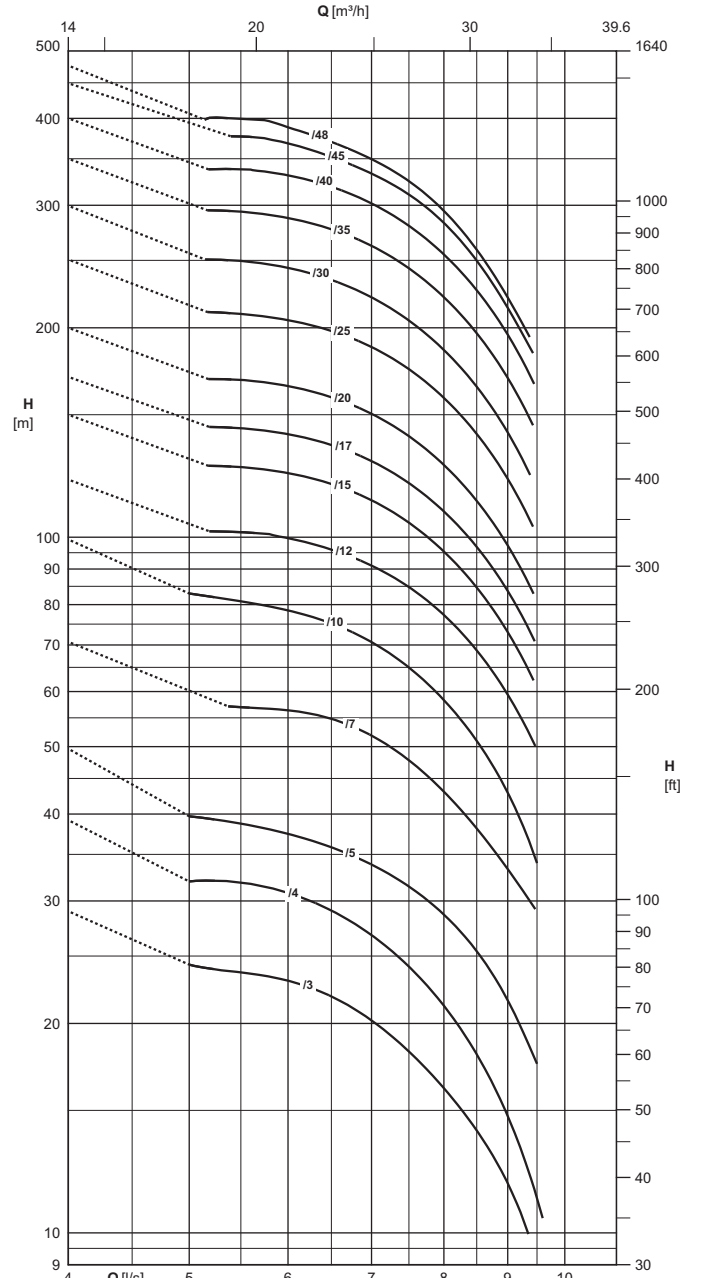

The hydraulic performance characteristics are guaranteed as conforming to standard UNI/ISO 9906 Grade 3B.  
The hydraulic characteristics of units coupled to MAC 6...-2B 6" motors are guaranteed as conforming to standard UNI/ISO 9906 Grade 2B.

Les caractéristiques hydrauliques de fonctionnement sont garanties conformes à la norme UNI/ISO 9906 Niveau 3B.  
Pour les groupes accouplés à des moteurs 6" MAC 6...-2B les caractéristiques hydrauliques sont garanties conformes à la norme UNI/ISO 9906 Niveau 2B.

Le caratteristiche idrauliche di funzionamento vengono garantite secondo la norma UNI/ISO 9906 Grado 3B.  
Per i gruppi accoppiati a motori 6" MAC 6...-2B le caratteristiche idrauliche vengono garantite secondo la norma UNI/ISO 9906 Grado 2B.

Electric pump type Electropompe type Elettropompa tipo	Motor power Puisse. moteur Potenza motore		Horizontal installation Installation horizontale Installazione orizzontale	Check valve $\varnothing$ Clapet de retenue $\varnothing$ Valvola di ritegno $\varnothing$	Capacity Debit Portata											
					[l/s]	0	5	5,5	6	6,5	7	7,5	8	8,5	9	9,5
	[l/min]	0			300	330	360	390	420	450	480	510	540	570		
	[m <sup>3</sup> /h]	0			18	19,8	21,6	23,4	25,2	27	28,8	30,6	32,4	34,2		
[kW]	[HP]	Head Hauteur Prevalenza														
E6XD50/3+MCH43	2,2	3	■	2 1/2" Gas	[m]	29	24,5	23,5	23	22	20	18	16	14	12	-
E6XD50/4+MCH44	3	4	■	2 1/2" Gas	[m]	39	32	32	31	29	27	24	21	18	14,5	11
E6XD50/5+MCH455	4	5,5	■	2 1/2" Gas	[m]	49,5	39,5	38,5	37,5	36	34	31,5	28,5	25,5	21,5	17,5
E6XD50/5+MAC65A	4	5,5	■	2 1/2" Gas	[m]	51	43,5	42	40,5	38,5	36,5	33,5	30,5	27	23,5	-
E6XD50/7+MCR475	5,5	7,5	○	2 1/2" Gas	[m]	71	-	57	56	55	52	48	43	38	33,5	-
E6XD50/7+MAC67A	5,5	7,5	■	2 1/2" Gas	[m]	70	-	59	58	56	53	49,5	45	40	34,5	-
E6XD50/10+MCR410	7,5	10	○	2 1/2" Gas	[m]	99	83	81	78	75	70	65	58	51	43	34
E6XD50/10+MAC610A	7,5	10	■	2 1/2" Gas	[m]	101	-	84	83	80	76	71	64	57	49,5	-
E6XD50/12+MAC612A	9,2	12,5	■	2 1/2" Gas	[m]	121	-	102	99	96	91	85	77	69	59	-
E6XD50/15+MAC615A	11	15	■	2 1/2" Gas	[m]	150	-	126	123	119	113	105	95	84	73	-
E6XD50/17+MAC617A	13	17,5	■	2 1/2" Gas	[m]	170	-	143	140	136	128	119	109	97	84	-
E6XD50/20+MAC620A	15	20	■	2 1/2" Gas	[m]	200	-	168	165	159	150	139	127	113	97	-
E6XD50/25+MAC625A	18,5	25	■	2 1/2" Gas	[m]	251	-	209	205	198	187	174	158	141	121	-
E6XDB50/30+MAC630A	22	30	■	2 1/2" Gas	[m]	299	-	249	244	234	221	205	186	164	141	-
E6XDB50/35+MAC635A	26	35	○	2 1/2" Gas	[m]	350	-	293	287	277	262	243	221	196	169	-
E6XDB50/40+MAC640A	30	40	○	2 1/2" Gas	[m]	400	-	338	331	319	302	280	255	226	195	-
E6XDB50/45+MAC650B	37	50	○	2 1/2" Gas	[m]	449	-	376	368	352	333	311	283	250	214	-
E6XDB50/48+MAC650B	37	50	○	2 1/2" Gas	[m]	476	-	399	388	370	349	325	294	259	221	-
NPSH					[m]	-	-	-	2	2	2,2	2,6	3,9	4,2	5,4	-

M.E.I.  $\geq 0.10$

■ Without conical valve

□ On request

○ Please contact our sales organisation

For motor performances specification see page "motor features"

■ Sans soupape du clapet.

□ Sur demande

○ Contacter notre service commercial.

Pour caractéristiques techniques moteurs voir page "Caractéristiques des moteurs"

■ Senza clapet valvola di ritegno

□ Su richiesta

○ Interpellare la sede o la rete di vendita

Per caratteristiche motori vedere pagina caratteristiche motori

Temperature monitoring device for submersed electric motors 4" + 6": Appareillage de contrôle de la température des moteurs électriques immergés 4" + 6": voir page "Accessories"

Apparecchiatura di controllo temperatura motori elettrici sommersi 4" + 6": vedere pagina accessori

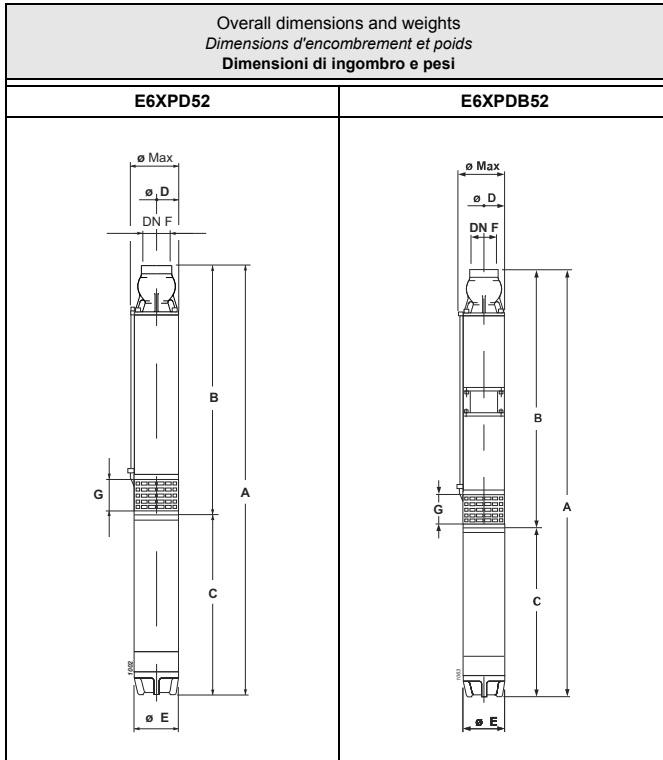

Type Type Tipo	Ø max [mm]	Weight Poids Peso [kg]	[mm]							F
			A	B	C	D	E	G		
E6XPD52/2AB+MCH43	135	21,5	959	484	475	127	96	100	G3	
E6XPD52/3B+MCH44	135	25	1059	544	515	127	96	100	G3	
E6XPD52/3A+MCH455	135	28,5	1084	544	540	127	96	100	G3	
E6XPD52/3A+MAC65A	145	40,5	1074	544	530	141	143	100	G3	
E6XPD52/4A+MCR475	135	35,5	1289	604	685	127	96	100	G3	
E6XPD52/4A+MAC67A	145	44	1154	604	550	141	143	100	G3	
E6XPD52/6K+MCR410	135	42	1494	724	770	127	96	100	G3	
E6XPD52/6K+MAC610A	145	51,5	1319	724	595	141	143	100	G3	
E6XPD52/7A+MAC612A	145	56,5	1424	784	640	141	143	100	G3	
E6XPD52/9K+MAC615A	145	61,5	1633	963	670	141	143	100	G3	
E6XPD52/10I+MAC617A	145	66	1723	1023	700	141	143	100	G3	
E6XPD52/12K+MAC620A	145	72,5	1858	1143	715	141	143	100	G3	
E6XPD52/14A+MAC625A	145	78,5	2013	1263	750	141	143	100	G3	
E6XPDB52/17A+MAC630A	145	86	2440	1650	790	141	143	100	G3	
E6XPDB52/19A+MAC635A	145	98,5	2645	1770	875	141	143	100	G3	
E6XPDB52/22A+MAC640A	145	117,5	2975	1950	1025	141	143	100	G3	
E6XPD52/25A+MAC650B	145	146,5	3357	2130	1227	141	143	100	G3	
E6XPDB52/28A+MAC650B	145	150	3537	2310	1227	141	143	100	G3	

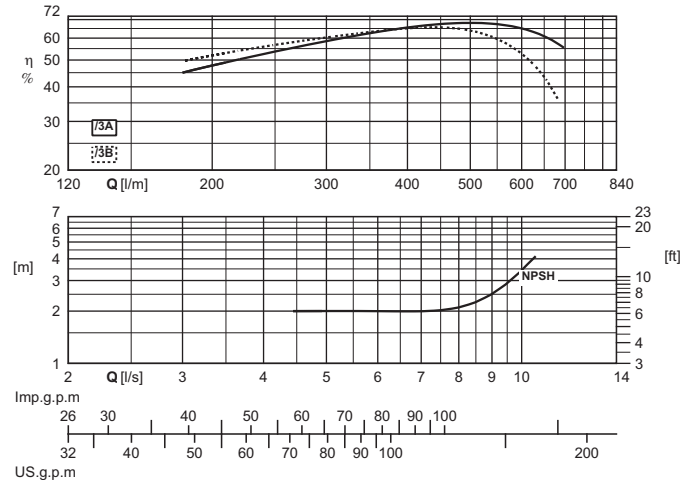
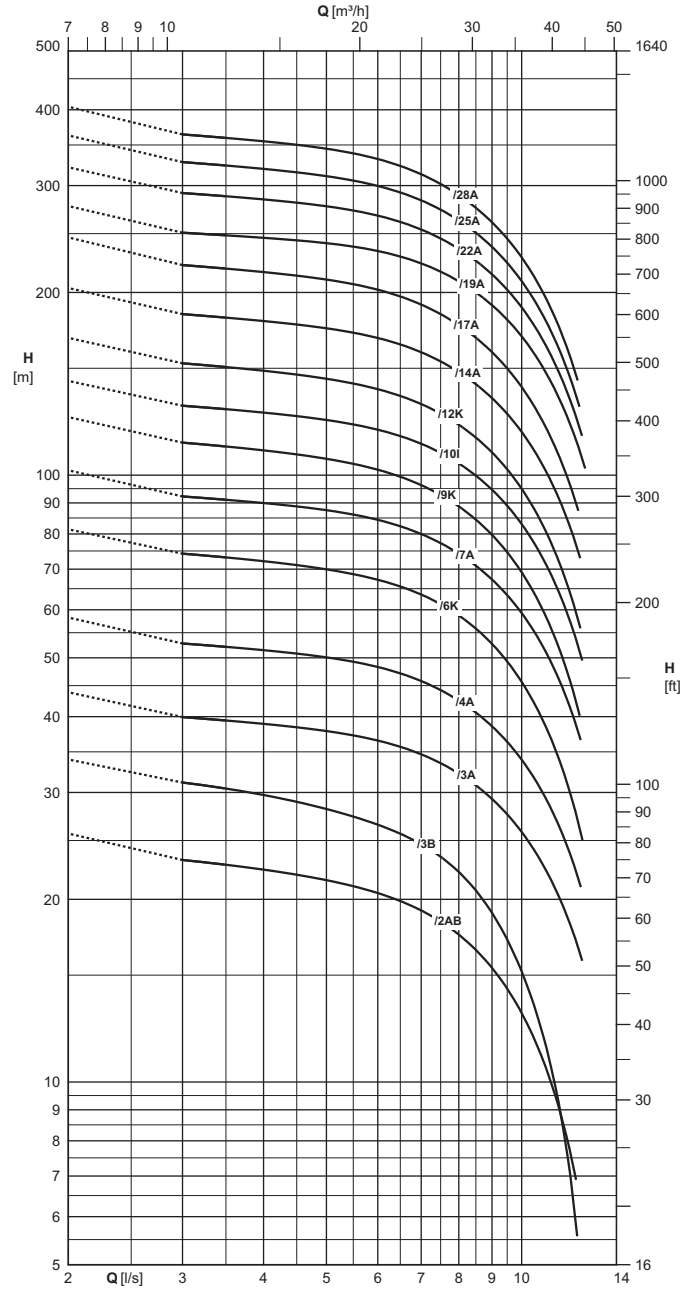

The hydraulic performance characteristics are guaranteed as conforming to standard UNI/ISO 9906 Grade 3B.  
The hydraulic characteristics of units coupled to MAC 6...-2B 6" motors are guaranteed as conforming to standard UNI/ISO 9906 Grade 2B.

Les caractéristiques hydrauliques de fonctionnement sont garanties conformes à la norme UNI/ISO 9906 Niveau 3B.  
Pour les groupes accouplés à des moteurs 6" MAC 6...-2B les caractéristiques hydrauliques sont garanties conformes à la norme UNI/ISO 9906 Niveau 2B.

Le caratteristiche idrauliche di funzionamento vengono garantite secondo la norma UNI/ISO 9906 Grado 3B.  
Per i gruppi accoppiati a motori 6" MAC 6...-2B le caratteristiche idrauliche vengono garantite secondo la norma UNI/ISO 9906 Grado 2B.

Electric pump type Electropompe type Elettropompa tipo	Motor power Puisse. moteur Potenza motore		Horizontal installation Installation horizontale Installazione orizzontale	Check valve Ø Clapet de retenue Ø Valvola di ritegno Ø	Capacity Debit Portata																		
	[kW]	[HP]			[l/s]	0	3	3,5	4	4,5	5	5,5	6	6,5	7	7,5	8	8,5	9	9,5	10	11	12
					[l/min]	0	180	210	240	270	300	330	360	390	420	450	480	510	540	570	600	660	720
					[m³/h]	0	10,8	12,6	14,4	16,2	18	19,8	21,6	23,4	25,2	27	28,8	30,6	32,4	34,2	36	39,6	43,2
Head Hauteur Prevalenza																							
E6XPD52/2AB+MCH43	2,2	3	■	3" Gas	[m]	25,5	23	23	22,5	22	21,5	21	20,5	20	19	18,5	17,5	16,5	15,5	14	13	10,5	7,3
E6XPD52/3B+MCH44	3	4	■	3" Gas	[m]	34	31	30,5	29,5	29	28	27,5	26,5	25,5	24,5	23,5	22	20,5	19	17	15	11	6,4
E6XPD52/3A+MCH455	4	5,5	■	3" Gas	[m]	44	40	39,5	39	38,5	38	37,5	36,5	35,5	34,5	33,5	32	31	29,5	27,5	26	22	17,5
E6XPD52/3A+MAC65A	4	5,5	■	3" Gas	[m]	44	40	39,5	39	38,5	38	37,5	36,5	35,5	34,5	33,5	32	31	29,5	27,5	26	22	17,5
E6XPD52/4A+MCR475	5,5	7,5	○	3" Gas	[m]	57	52	51	50	49,5	48,5	47,5	46	45	43,5	41,5	39,5	37,5	35	32,5	29,5	24	17,5
E6XPD52/4A+MAC67A	5,5	7,5	■	3" Gas	[m]	58	53	52	51	51	50	49,5	48,5	47	46	44	42,5	40,5	38,5	36,5	34	28,5	23
E6XPD52/6K+MCR410	7,5	10	○	3" Gas	[m]	81	74	73	72	71	70	69	67	65	64	61	59	56	53	49,5	45,5	37,5	29
E6XPD52/6K+MAC610A	7,5	10	■	3" Gas	[m]	81	74	73	72	71	70	69	67	65	64	61	59	56	53	49,5	45,5	37,5	29
E6XPD52/7A+MAC612A	9,2	12,5	■	3" Gas	[m]	102	92	91	90	89	87	86	84	82	80	77	74	71	67	63	59	50	40
E6XPD52/9K+MAC615A	11	15	■	3" Gas	[m]	124	113	111	110	108	106	104	102	99	96	93	89	84	80	74	69	57	44
E6XPD52/10I+MAC617A	13	17,5	■	3" Gas	[m]	143	130	128	127	125	123	121	119	116	112	109	104	100	94	89	83	70	56
E6XPD52/12K+MAC620A	15	20	■	3" Gas	[m]	168	153	151	148	146	144	141	138	135	131	126	121	115	109	102	95	79	62
E6XPD52/14A+MAC625A	18,5	25	■	3" Gas	[m]	203	184	182	179	177	174	172	168	164	159	154	148	141	134	126	118	99	79
E6XPDB52/17A+MAC630A	22	30	■	3" Gas	[m]	246	222	219	216	213	210	206	202	197	191	184	176	168	159	150	139	117	93
E6XPDB52/19A+MAC635A	26	35	○	3" Gas	[m]	278	251	248	246	244	241	238	234	229	223	216	208	200	190	180	169	145	118
E6XPDB52/22A+MAC640A	30	40	○	3" Gas	[m]	322	292	288	285	281	277	273	268	261	254	245	236	225	214	202	189	160	129
E6XPDB52/25A+MAC650B	37	50	○	3" Gas	[m]	363	328	324	320	315	311	306	299	292	283	274	263	251	238	224	209	176	140
E6XPDB52/28A+MAC650B	37	50	○	3" Gas	[m]	405	364	359	355	350	345	339	332	323	313	302	289	276	261	245	228	192	151
NPSH					[m]	-	-	-	-	2	2	2	2	2	2	2	2,1	2,2	2,5	2,9	3,4	5	-

■ Without conical valve

○ On request

○ Please contact our sales organisation

For motor performances specification see page "motor features"

Temperature monitoring device for submersed electric motors 4" + 6": see page "Accessories"

■ Sans soupape du clapet.

○ Sur demande

○ Contacter notre service commercial.

Pour caractéristiques techniques moteurs voir page "Caractéristiques des moteurs"

Appareillage de contrôle de la température des moteurs électriques immergés 4" + 6": voir page "Accessories"

■ Senza clapet valvola di ritegno

○ Su richiesta

○ Interpellare la sede o la rete di vendita

Per caratteristiche motori vedere pagina caratteristiche motori

Apparecchiatura di controllo temperatura motori elettrici sommersi 4" + 6": vedere pagina accessori

Friction losses  
 Pertes de charge  
 Perdite di carico

In feet every 100 feet of straight pipeline  
 En mètres pour 100 mètres de tuyauterie droite  
 In metri ogni 100 metri di tubazione diritta

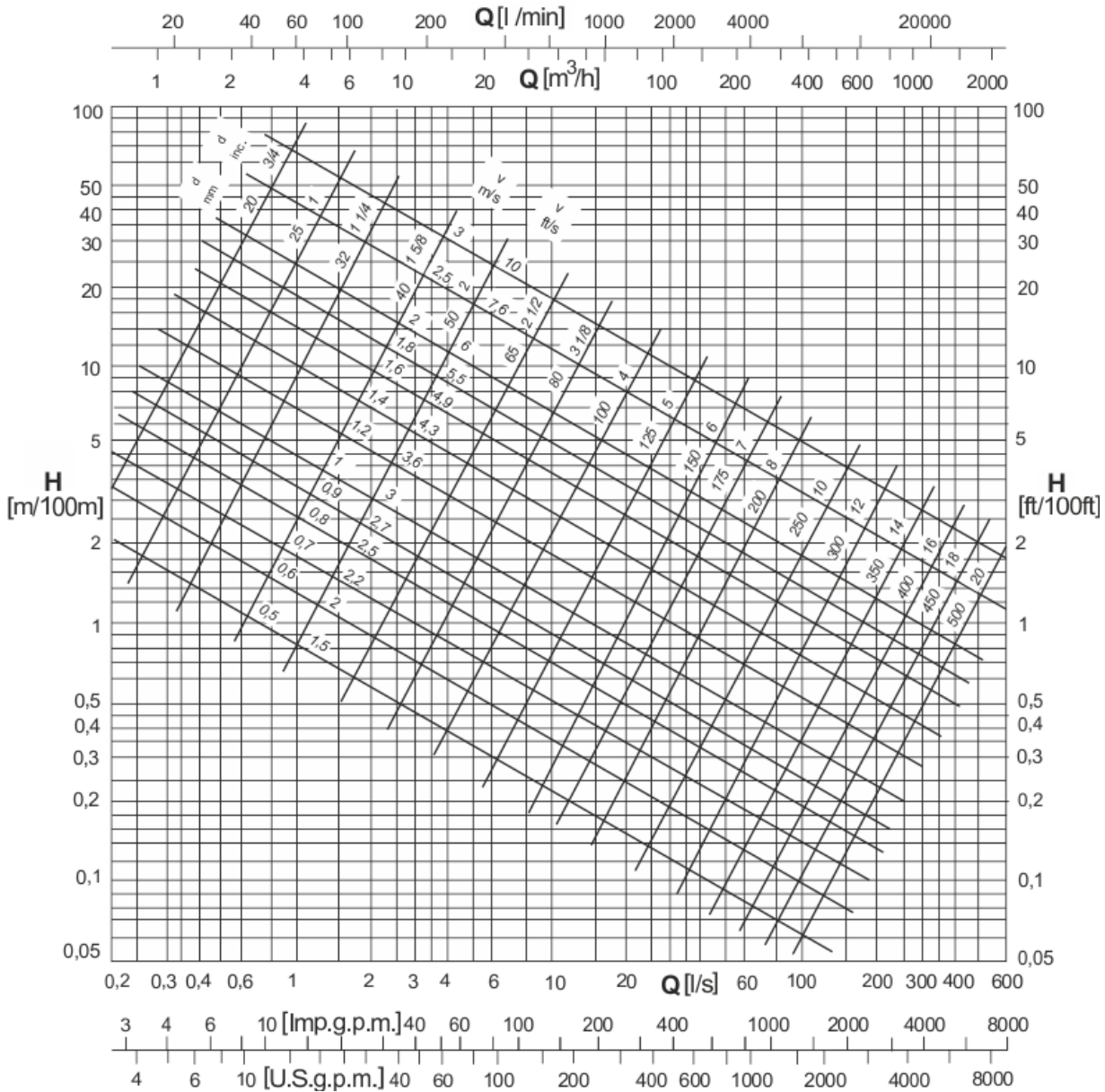

Notes: Above mentioned values are to be intended for internally smooth cast iron pipes.

For an estimated evaluation, friction losses must be multiplied for:

- 0,8 for new rolled steel pipes
- 1,25 for slightly rusted steel pipes
- 0,7 for aluminium pipes
- 0,65 for PVC pipes
- 1,25 for asbestos cement pipes

Q = Capacity  
 v = Velocity of water  
 d = Diameter of pipe  
 h = Friction loss

Notes: Les valeurs doivent s'entendre pour tuyaux en fonte, lisses à l'intérieur.

Pour une évaluation approximative, les pertes de charge doivent être multipliées par:

- 0,8 pour tuyaux laminés nouveaux en acier
- 1,25 pour tuyaux légèrement rouillés en acier
- 0,7 pour tuyaux en aluminium
- 0,65 pour tuyaux en PVC
- 1,25 pour tuyaux en fibro-ciment

Q = Débit  
 v = Vitesse de l'eau  
 d = Diamètre du tuyau  
 h = Perte de charge

Note: I valori sopra indicati s'intendono per tubi lisci in ghisa.

Per una valutazione di massima, le perdite di carico devono essere moltiplicate per:

- 0,8 per tubi di acciaio laminati nuovi
- 1,25 per tubi di acciaio leggermente arrugginiti
- 0,7 per tubi di alluminio
- 0,65 per tubi in PVC
- 1,25 per tubi in fibro-cemento

Q = portata  
 v = velocità dell'acqua  
 d = diametro del tubo  
 h = perdita di carico

Single-phase motors 4" 2 Poles / 50 Hz Moteurs monophasés 4" à 2 Pôles / 50 Hz Motori monofase 4" a 2 Poli / 50 Hz													
Motor type Moteur type Motore tipo	Motor power Puiss. moteur Potenza motore		Max water temperature Température max eau Temperatura max acqua	Starts / hour max Max démarrages / heure Max avviamenti/ora	Revolutions per minute Tours minute Giri al minuto	Efficiency Rendement Rendimento		Power factor Facteur de puissance Fattore di potenza		Nominal current Intensité nominale Corrente nominale		Starting Démarrage Avviamento	
	[kW]	[HP]				[°C]	[No.]	[n <sup>-1</sup> ]	3/4	4/4	3/4	4/4	3/4
				(1)	220 230 240	220 230 240	220 230 240	220 230 240	220 230 240	220 230 240	Fully loaded A pleine charge A pieno carico	Not loaded A vide A vuoto	Direct Direct Diretto
MC405M	0,37	0,5	35	20	2830 2840 2820	47,0 44,5 42,0	53,0 51,0 49,5	0,990 0,970 0,930	0,990 0,980 0,955	3,2 3,2 3,3	1,9 2,2 2,6	1	3,4
MC4075M	0,55	0,75	35	20	2815 2820 2855	53,5 51,0 48,5	59,5 58,0 55,5	0,985 0,955 0,920	0,990 0,980 0,960	4,2 4,2 4,3	2,3 2,8 3,5	0,87	3,3
MC41M	0,75	1	35	20	2820 2830 2860	57,0 54,5 51,0	63,5 61,5 58,0	0,975 0,940 0,895	0,980 0,970 0,940	5,4 5,5 5,8	3,1 3,9 4,8	1	3,7
MCH415M	1,1	1,5	35	20	2770 2795 2825	58,2 57,4 57,3	61,4 61,2 61,8	0,966 0,939 0,910	0,973 0,963 0,955	8,3 8,1 7,7	3,8 4,7 5,5	0,84	3,6
MCH42M	1,5	2	35	20	2755 2785 2815	65,8 64,3 62,7	65,9 66,8 67,6	0,911 0,863 0,820	0,934 0,912 0,890	11,1 10,7 10,3	6,2 7,2 8,2	0,85	3,3
MCH43M	2,2	3	35	15	2795 2815 2835	63,6 62,1 60,5	68,1 67,3 66,4	0,990 0,967 0,949	0,997 0,993 0,993	14,7 14,3 13,9	6,6 7,8 9,0	0,75	3,3
MCK42M	1,5	2	35	20	2755 2785 2815	65,8 64,3 62,7	65,9 66,8 67,6	0,911 0,863 0,820	0,934 0,912 0,890	11,1 10,7 10,3	6,2 7,2 8,2	0,85	3,3
MCK43M	2,2	3	35	15	2795 2815 2835	63,6 62,1 60,5	68,1 67,3 66,4	0,990 0,967 0,949	0,997 0,993 0,993	14,7 14,3 13,9	6,6 7,8 9,0	0,75	3,3
MCK455M	4	5,5	35	15	2875 2885 -	71,1 66,4 -	74,4 71,5 -	0,862 0,785 -	0,916 0,870 -	26,6 27,9 -	17,5 23,2 -	0,92	4,2

Ma = Starting torque  
Mn = Nominal couple  
la = Starting current  
In = Nominal current

Direction of rotation = Left (anti-clockwise) viewed from shaft projection side

(1) = Equally distributed

To supply voltages and admitted variations see the chapter: Motor general notes

Ma = Couple au démarrage

Mn = Couple nominale

la = Intensité au démarrage

In = Intensité nominale

Sens de rotation = Gauche (antihoraire) vu du côté bout d'arbre

(1) = Uniformement repartis

Pour les tensions d'alimentation et les variations admises voir le chapitre: Remarques générales moteur

Ma = Coppia di avviamento

Mn = Coppia nominale

la = Corrente di avviamento

In = Corrente nominale

Senso di rotazione = Sinistro (antiorario) visto lato sporgenza albero

(1) = Equamente ripartiti

Per le tensioni di alimentazione e le variazioni ammesse vedere il capitolo: Note generali motore



Three-phase motors 4" 2 Poles / 50 Hz Moteurs triphasés 4" à 2 Pôles / 50 Hz Motori trifase 4" a 2 Poli / 50 Hz													
Motor type Moteur type Motore tipo	Motor power Puiss. moteur Potenza motore		Max water temperature Température max eau Temperatura max acqua	Starts / hour max Max démarrages / heure Max avviamenti/ora	Revolutions per minute Tours minute Giri al minuto	Efficiency Rendement Rendimento		Power factor Facteur de puissance Fattore di potenza		Nominal current Intensité nominale Corrente nominale		Starting Démarrage Avviamento	
	[kW]	[HP]				[°C]	[No.]	[n <sup>-1</sup> ]	3/4	4/4	3/4	4/4	3/4
				(1)	400	400	400	400	400	400	Fully loaded A pleine charge A pieno carico	Not loaded A vide A vuoto	Direct Direct Diretto
MC405	0,37	0,5	35	20	2820	53,0	58,0	0,690	0,760	1,2	0,9	2	3,6
MC4075	0,55	0,75	35	20	2815	61,0	64,0	0,645	0,740	1,7	1,4	1,93	3,9
MC41	0,75	1	35	20	2815	61,5	64,5	0,625	0,720	2,3	1,9	2,03	4,4
MCH415	1,1	1,5	35	20	2825	70,4	71,8	0,722	0,797	2,8	1,8	2,74	5,2
MCH42	1,5	2	35	20	2815	65,9	67,5	0,707	0,792	4,0	3,0	2,39	4,4
MCH43	2,2	3	35	20	2800	69,6	69,5	0,704	0,807	5,6	4,4	2,63	4,9
MCH44	3	4	35	20	2800	71,3	71,5	0,700	0,796	7,6	5,3	3,05	4,6
MCH455	4	5,5	35	20	2830	76,3	76,0	0,699	0,798	9,5	6,5	3,15	6
MCK42	1,5	2	35	20	2815	65,9	67,5	0,707	0,792	4,0	3,0	2,39	4,4
MCK43	2,2	3	35	20	2800	69,6	69,5	0,704	0,807	5,6	4,4	2,63	4,9
MCR410	7,5	10	35	15	2815	80,2	79,0	0,710	0,811	16,9	11,6	3,9	7,5
MCR44	3	4	35	20	2855	76,6	77,5	0,621	0,724	7,7	6,4	3,4	6,3
MCR455	4	5,5	35	15	2855	77,4	77,8	0,600	0,719	10,3	8,4	3,4	8,1
MCR475	5,5	7,5	35	15	2835	77,8	78,2	0,688	0,790	12,9	9,4	3,9	7,5

Ma = Starting torque

Mn = Nominal couple

Ia = Starting current

In = Nominal current

Direction of rotation = Left (anti-clockwise) viewed from shaft projection side

(1) = Equally distributed

To supply voltages and admitted variations see the chapter: Motor general notes

Ma = Couple au démarrage

Mn = Couple nominale

Ia = Intensité au démarrage

In = Intensité nominale

Sens de rotation = Gauche (antioraire) vu du côté bout d'arbre

(1) = Uniformement repartis

Pour les tensions d'alimentation et les variations admises voir le chapitre: Remarques générales moteur

Ma = Coppia di avviamento

Mn = Coppia nominale

Ia = Corrente di avviamento

In = Corrente nominale

Senso di rotazione = Sinistro (antiorario) visto lato sporgenza albero

(1) = Equamente ripartiti

Per le tensioni di alimentazione e le variazioni ammesse vedere il capitolo: Note generali motore

Three-phase motors 2 Poles / 50 Hz Moteurs triphasés à 2 Pôles / 50 Hz Motori trifase a 2 Poli / 50 Hz															
Motor type Moteur type Motore tipo	Motor power Puiss. moteur Potenza motore		Max water temperature Température max eau Temperatura max acqua	Starts / hour max Max démarrages / heure Max avviamenti / ora	Revolutions per minute Tours minute Giri al minuto	Efficiency Rendement Rendimento		Power factor Facteur de puissance Fattore di potenza		Nominal current Intensité nominale Corrente nominale		Starting Démarrage Avviamento			
	[kW]	[HP]	[°C]	[No.]	[n ·']	3/4	4/4	3/4	4/4	Fully loaded A pleine charge A pieno carico	Not loaded A vide A vuoto	Direct Direct Diretto		Star-delta Etoile- triangle Stella- triangolo	Statoric Statorique Statorico
				(1)	400	400	400	400	400	400	400	400	400	400	400
MAC65-2A	4	5,5	30	15	2825	67,5	70,0	0,695	0,800	10,3	8,4	1,5	3	1,00	2,10
MAC67-2A	5,5	7,5	30	15	2815	71,5	72,0	0,720	0,805	13,7	9,3	1,5	3,2	1,05	2,25
MAC610-2A	7,5	10	30	15	2830	75,5	75,5	0,720	0,800	17,9	11,7	2	4,1	1,40	2,90
MAC612-2A	9,2	12,5	30	15	2840	77,5	77,5	0,730	0,820	20,8	14,4	1,7	4	1,32	2,80
MAC615-2A	11	15	30	15	2835	78,5	77,5	0,755	0,825	24,8	14,2	2,5	5,2	1,70	3,60
MAC617-2A	13	17,5	30	15	2840	78,0	79,0	0,685	0,800	29,7	23,4	2,6	5	1,65	3,50
MAC620-2A	15	20	30	15	2855	81,0	80,5	0,720	0,800	33,7	18,6	1,95	5	1,70	3,50
MAC625-2A	18,5	25	25	15	2840	81,5	81,0	0,735	0,820	40,2	22,4	2,5	5,4	1,80	3,80
MAC630-2A	22	30	25	13	2820	82,5	80,5	0,755	0,825	48,0	23,4	1,7	4,5	1,50	3,20
MAC635-2A	26	35	25	13	2850	84,0	83,0	0,740	0,815	55,6	28,4	2	5,3	1,75	3,70
MAC640-2A	30	40	25	13	2850	86,5	85,0	0,740	0,805	63,3	33,2	2	5,3	1,70	3,70
MAC65-2B	4	5,5	40	15	2870	76,0	76,0	0,745	0,800	9,5	4,6	1,3	3,5	1,15	2,45
MAC67-2B	5,5	7,5	40	15	2880	77,0	77,0	0,745	0,805	12,8	6,1	1,9	4	1,30	2,80
MAC610-2B	7,5	10	40	15	2855	78,5	77,5	0,770	0,820	17,0	7,6	2,4	5,1	1,70	3,60
MAC612-2B	9,2	12,5	40	15	2875	78,5	79,0	0,750	0,810	20,8	9,8	2,4	5	1,65	3,50
MAC615-2B	11	15	40	15	2860	81,0	80,5	0,755	0,810	24,3	10,6	2,6	5,4	1,80	3,80
MAC617-2B	13	17,5	40	15	2865	82,0	81,5	0,745	0,810	28,4	13,6	1,3	4,6	1,50	3,20
MAC620-2B	15	20	40	15	2875	82,0	82,0	0,735	0,800	33,0	17,4	1,5	5	1,70	3,50
MAC625-2B	18,5	25	40	15	2850	83,0	81,5	0,785	0,830	39,5	16,5	1,4	4,7	1,55	3,30
MAC630-2B	22	30	40	13	2860	83,5	83,5	0,750	0,820	46,4	22,4	1,8	5	1,70	3,50
MAC635-2B	26	35	40	13	2860	85,5	84,5	0,745	0,805	55,0	26,7	1,5	4,8	1,60	3,35
MAC640-2B	30	40	40	13	2870	86,5	85,0	0,755	0,815	62,5	28,3	2	5,7	1,90	4,00
MAC650-2B	37	50	40	13	2870	87,0	86,0	0,720	0,800	77,5	41,6	2,4	6	2,00	4,20
MAC660-2B	45	60	40	6	2860	85,0	84,5	0,730	0,800	96,0	49,9	2	5,1	1,70	3,55

Ma = Starting torque

Mn = Nominal couple

Ia = Starting current

In = Nominal current

Direction of rotation = Left (anti-clockwise) viewed from shaft projection side

(1) = Equally distributed

To supply voltages and admitted variations see the chapter: Motor general notes

Ma = Couple au démarrage

Mn = Couple nominale

Ia = Intensité au démarrage

In = Intensité nominale

Sens de rotation = Gauche (antihoraire) vu du côté bout d'arbre

(1) = Uniformement repartis

Pour les tensions d'alimentation et les variations admises voir le chapitre: Remarques générales moteur

Ma = Coppia di avviamento

Mn = Coppia nominale

Ia = Corrente di avviamento

In = Corrente nominale

Senso di rotazione = Sinistro (antiorario) visto lato sporgenza albero

(1) = Equamente ripartiti

Per le tensioni di alimentazione e le variazioni ammesse vedere il capitolo: Note generali motore

Single-phase and three-phase motors 2 Pole / 50 Hz - Overall dimensions and weights  
 Moteurs monophasés et triphasés 2 Pôles / 50 Hz - Dimensions d'encombrement et poids  
 Motori monofase e trifase a 2 Poli / 50 Hz - Dimensioni di ingombro e pesi

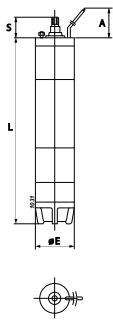
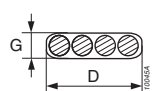
	Motor type Moteur type Motore tipo	Coupling flange Bride d'accouplement Flangia accoppiamento	Motor weight Poids moteur Peso motore	L	Ø E	S	Cables outlet Sortie des câbles Uscita cavi		
							Length A Longueur A Lunghezza A	Cross section [mm <sup>2</sup> ] Section en [mm <sup>2</sup> ] Sezione in [mm <sup>2</sup> ]	
								Starting Démarrage Avviamento	
								Direct Direct Diretto	
				[mm]		[m]	220 - 230	230 - 240	
	MC405M	NEMA 4"	8,1	340	96	38	1,5	1 x (4x1,5) (C.C.:1)	1 x (4x1,5) (C.C.:2)
	MC4075M	NEMA 4"	9,2	340	96	38	1,5	1 x (4x1,5) (C.C.:1)	1 x (4x1,5) (C.C.:2)
	MC41M	NEMA 4"	10,3	360	96	38	1,5	1 x (4x1,5) (C.C.:1)	1 x (4x1,5) (C.C.:2)
	MCH415M	NEMA 4"	11,4	450	96	38	1,5	1 x (4x1,5) (C.C.:1)	1 x (4x1,5) (C.C.:2)
	MCH42M	NEMA 4"	12,8	475	96	38	1,5	1 x (4x1,5) (C.C.:1)	1 x (4x1,5) (C.C.:2)
	MCH43M	NEMA 4"	17,4	580	96	38	2	1 x (4x1,5) (C.C.:1)	1 x (4x1,5) (C.C.:2)
	MCK42M	NEMA 4"	14,6	475	96	38	1,5	1 x (4x1,5) (C.C.:1)	1 x (4x1,5) (C.C.:2)
	MCK43M	NEMA 4"	17,4	580	96	38	2	1 x (4x1,5) (C.C.:1)	1 x (4x1,5) (C.C.:2)
	MCK455M	NEMA 4"	24,4	700	96	38	2	1 x (4x1,5) (C.C.:1)	-
Section Section Sezione		G				D			
[mm <sup>2</sup> ]						[mm]			
	4 x 1,5	5				15			
	4 x 2,5	5,5				18			

C.C = Motor manufacturing code

C.C = Code construction moteur

C.C = Codice costruttivo motore

Single-phase and three-phase motors 2 Pole / 50 Hz - Overall dimensions and weights  
 Moteurs monophasés et triphasés 2 Pôles / 50 Hz - Dimensions d'encombrement et poids  
 Motori monofase e trifase a 2 Poli / 50 Hz - Dimensioni di ingombro e pesi

	Motor type Moteur type Motore tipo	Coupling flange Bride d'accouplement Flangia accoppiamento	Motor weight Poids moteur Peso motore	L	Ø E	S	Cables outlet Sortie des câbles Uscita cavi		
							Length A Longueur A Lunghezza A	Cross section [mm <sup>2</sup> ] Section en [mm <sup>2</sup> ] Sezione in [mm <sup>2</sup> ]	
								Starting Démarrage Avviamento	
								Direct Direct Diretto	
				[mm]		[m]	230	400	
	MC405	NEMA 4"	7,4	320	96	38	1,5	1 x (4x1,5) (C.C.:6)	1 x (4x1,5) (C.C.:8)
	MC4075	NEMA 4"	8	340	96	38	1,5	1 x (4x1,5) (C.C.:6)	1 x (4x1,5) (C.C.:8)
	MC41	NEMA 4"	8,8	340	96	38	1,5	1 x (4x1,5) (C.C.:6)	1 x (4x1,5) (C.C.:8)
	MCH415	NEMA 4"	10,1	420	96	38	1,5	1 x (4x1,5) (C.C.:6)	1 x (4x1,5) (C.C.:8)
	MCH42	NEMA 4"	10,8	447	96	38	1,5	1 x (4x1,5) (C.C.:6)	1 x (4x1,5) (C.C.:8)
	MCH43	NEMA 4"	12,5	475	96	38	2	1 x (4x1,5) (C.C.:6)	1 x (4x1,5) (C.C.:8)
	MCH44	NEMA 4"	15	515	96	38	2	1 x (4x1,5) (C.C.:6)	1 x (4x1,5) (C.C.:8)
	MCH455	NEMA 4"	18,3	540	96	38	2	1 x (4x1,5) (C.C.:6)	1 x (4x1,5) (C.C.:8)
	MCK42	NEMA 4"	10,8	447	96	38	1,5	1 x (4x1,5) (C.C.:6)	1 x (4x1,5) (C.C.:8)
	MCK43	NEMA 4"	12,5	475	96	38	2	1 x (4x1,5) (C.C.:6)	1 x (4x1,5) (C.C.:8)
	**MCR410	NEMA 4"	28,5	770	96	38	3	1 x (4x1,5) (C.C.:6)	1 x (4x1,5) (C.C.:8)
	**MCR44	NEMA 4"	18	520	96	38	2,3	1 x (4x1,5) (C.C.:6)	1 x (4x1,5) (C.C.:8)
	**MCR455	NEMA 4"	21,4	590	96	38	2,3	1 x (4x1,5) (C.C.:6)	1 x (4x1,5) (C.C.:8)
	**MCR475	NEMA 4"	24,5	685	96	38	2,5	1 x (4x1,5) (C.C.:6)	1 x (4x1,5) (C.C.:8)
Section Section Sezione		G				D			
[mm <sup>2</sup> ]						[mm]			
	4 x 1,5	5				15			
	4 x 2,5	5,5				18			

C.C = Motor manufacturing code

C.C = Code construction moteur

C.C = Codice costruttivo motore

\*\* With plugging cable

\*\* Avec cable à connecteur extractible

\*\* Con cavo a connettore estraibile

Single-phase and three-phase motors 2 Pole / 50 Hz - Overall dimensions and weights  
 Moteurs monophasés et triphasés 2 Pôles / 50 Hz - Dimensions d'encombrement et poids  
 Motori monofase e trifase a 2 Poli / 50 Hz - Dimensioni di ingombro e pesi

	Motor type Moteur type Motore tipo	Coupling flange Bride d'accouplement Flangia accoppiamento	Motor weight Poids moteur Peso motore	L	Ø E	S	Length A Longueur A Lunghezza A	Cables outlet Sortie des câbles Uscita cavi				
								Cross section [mm <sup>2</sup> ] Section en [mm <sup>2</sup> ] Sezione in [mm <sup>2</sup> ]				
								Starting Démarrage Avviamento				
								Direct Direct Diretto		Star-delta Etoile-triangle Stella-triangolo		
[mm]				[m]				400	230	400 / 700	230 / 400	
	<b>HT</b> HI-TECH											
	MAC65-2A	NEMA 6"	30,5	530	143	73	3,5	3x(1x2,5) (C.C.:8)	-	6x(1x2,5) (C.C.:9)	-	-
	MAC67-2A	NEMA 6"	33	550	143	73	3,5	3x(1x2,5) (C.C.:8)	-	6x(1x2,5) (C.C.:9)	-	-
	MAC610-2A	NEMA 6"	38	595	143	73	3,5	3x(1x2,5) (C.C.:8)	-	6x(1x2,5) (C.C.:9)	-	-
	MAC612-2A	NEMA 6"	41,7	640	143	73	3,5	3x(1x2,5) (C.C.:8)	-	6x(1x2,5) (C.C.:9)	-	-
	MAC615-2A	NEMA 6"	44,4	670	143	73	3,5	3x(1x2,5) (C.C.:8)	-	6x(1x2,5) (C.C.:9)	-	-
	MAC617-2A	NEMA 6"	47,7	700	143	73	3,5	3x(1x4) (C.C.:8)	-	6x(1x4) (C.C.:9)	-	-
	MAC620-2A	NEMA 6"	52	715	143	73	3,5	3x(1x4) (C.C.:8)	-	6x(1x4) (C.C.:9)	-	-
	MAC625-2A	NEMA 6"	56	750	143	73	3,5	3x(1x4) (C.C.:8)	-	6x(1x4) (C.C.:9)	-	-
	MAC630-2A	NEMA 6"	59,8	790	143	73	3,5	3x(1x4) (C.C.:8)	-	6x(1x4) (C.C.:9)	-	-
MAC635-2A	NEMA 6"	70	875	143	73	3,5	3x(1x6) (C.C.:8)	-	6x(1x4) (C.C.:9)	-	-	
MAC640-2A	NEMA 6"	85,7	1025	143	73	3,5	3x(1x6) (C.C.:8)	-	6x(1x4) (C.C.:9)	-	-	
	<b>HTdesert</b> HI-TECH											
	MAC65-2B	NEMA 6"	39	552	143	73	3,5	3x(1x2,5) (C.C.:8)	3x(1x4) (C.C.:6)	6x(1x2,5) (C.C.:9)	6x(1x2,5) (C.C.:7)	
	MAC67-2B	NEMA 6"	42,7	572	143	73	3,5	3x(1x2,5) (C.C.:8)	3x(1x4) (C.C.:6)	6x(1x2,5) (C.C.:9)	6x(1x2,5) (C.C.:7)	
	MAC610-2B	NEMA 6"	48	597	143	73	3,5	3x(1x2,5) (C.C.:8)	3x(1x4) (C.C.:6)	6x(1x2,5) (C.C.:9)	6x(1x2,5) (C.C.:7)	
	MAC612-2B	NEMA 6"	51	642	143	73	3,5	3x(1x2,5) (C.C.:8)	3x(1x4) (C.C.:6)	6x(1x2,5) (C.C.:9)	6x(1x2,5) (C.C.:7)	
	MAC615-2B	NEMA 6"	53,7	672	143	73	3,5	3x(1x2,5) (C.C.:8)	3x(1x4) (C.C.:6)	6x(1x2,5) (C.C.:9)	6x(1x2,5) (C.C.:7)	
	MAC617-2B	NEMA 6"	58	717	143	73	3,5	3x(1x4) (C.C.:8)	3x(1x6) (C.C.:6)	6x(1x4) (C.C.:9)	6x(1x4) (C.C.:7)	
	MAC620-2B	NEMA 6"	61	752	143	73	3,5	3x(1x4) (C.C.:8)	3x(1x6) (C.C.:6)	6x(1x4) (C.C.:9)	6x(1x4) (C.C.:7)	
	MAC625-2B	NEMA 6"	68	792	143	73	3,5	3x(1x4) (C.C.:8)	3x(1x6) (C.C.:6)	6x(1x4) (C.C.:9)	6x(1x4) (C.C.:7)	
	MAC630-2B	NEMA 6"	85	877	143	73	3,5	3x(1x4) (C.C.:8)	3x(1x10) (C.C.:6)	6x(1x4) (C.C.:9)	6x(1x4) (C.C.:7)	
	MAC635-2B	NEMA 6"	92,5	1027	143	73	3,5	3x(1x6) (C.C.:8)	3x(1x10) (C.C.:6)	6x(1x4) (C.C.:9)	6x(1x6) (C.C.:7)	
	MAC640-2B	NEMA 6"	104	1137	143	73	3,5	3x(1x6) (C.C.:8)	3x(1x10) (C.C.:6)	6x(1x4) (C.C.:9)	6x(1x6) (C.C.:7)	
	MAC650-2B	NEMA 6"	111	1227	143	73	3,5	3x(1x10) (C.C.:8)	-	6x(1x6) (C.C.:9)	-	
MAC660-2B	NEMA 6"	119	1287	143	73	4,5	3x(1x10) (C.C.:8)	-	6x(1x6) (C.C.:9)	-		
Section Section Sezione		F										
[mm <sup>2</sup> ]		[mm]										
	1 x 2,5	6,2										
	1 x 4	6,7										
	1 x 6	7,4										
	1 x 10	8,6										
	1 x 16	10										
	1 x 25	11,9										
	1 x 35	13,1										
	1 x 50	15,7										
	1 x 70	18										
1 x 95	21											

C.C = Motor manufacturing code

C.C = Code construction moteur

C.C = Codice costruttivo motore

Dynamic momentum of the wet end  
*Moment dynamique partie hydraulique*  
 Momento dinamico parte idraulica

Standard construction <i>Exécution standard</i> Esecuzione standard		
Electric pump type <i>Electropompe type</i> Elettropompa tipo	J Wet <i>J Mouillé</i> J Bagnato	
	Single stage <i>Mono étagée</i> Monostadio	For each additional stage <i>Pour chaque étage en plus</i> Per ogni stadio in più
	J=1/4 PD <sup>2</sup> [kgm <sup>2</sup> ]	
E6XD20 ( x 4" )	0,000143	0,000026
E6XD20 ( x 6" )	0,000190	0,000026
E6XD25 ( x 4" )	0,000156	0,000026
E6XD25 ( x 6" )	0,000206	0,000026
E6XD30 ( x 4" )	0,000182	0,000052
E6XD30 ( x 6" )	0,000247	0,000052
E6XD35 ( x 4" )	0,000195	0,000065
E6XD35 ( x 6" )	0,000260	0,000065
E6XD40 ( x 4" )	0,000195	0,000065
E6XD40 ( x 6" )	0,000260	0,000065
E6XD50 ( x 4" )	0,000208	0,000078
E6XD50 ( x 6" )	0,000273	0,000078
E6XPD52 ( x 4" )	0,000208	0,000078
E6XPD52 ( x 6" )	0,000273	0,000078

Dynamic momentum of the motor  
*Moment dynamique moteur*  
**Momento dinamico motore**

Dynamic momentum of the motor <i>Moment dynamique moteur</i> <b>Momento dinamico motore</b>	
Motor type <i>Moteur type</i> <b>Motore tipo</b>	J=1/4 PD <sup>2</sup> [kgm <sup>2</sup> ]
	
MAC65-2A	0,0020
MAC67-2A	0,0025
MAC610-2A	0,0029
MAC612-2A	0,0045
MAC615-2A	0,0050
MAC617-2A	0,0054
MAC620-2A	0,0070
MAC625-2A	0,0081
MAC630-2A	0,0085
MAC635-2A	0,0110
MAC640-2A	0,0141

Dynamic momentum of the motor <i>Moment dynamique moteur</i> <b>Momento dinamico motore</b>	
Motor type <i>Moteur type</i> <b>Motore tipo</b>	J=1/4 PD <sup>2</sup> [kgm <sup>2</sup> ]
	
MAC65-2B	0,0025
MAC67-2B	0,0037
MAC610-2B	0,0042
MAC612-2B	0,0058
MAC615-2B	0,0064
MAC617-2B	0,0070
MAC620-2B	0,0081
MAC625-2B	0,0085
MAC630-2B	0,0110
MAC635-2B	0,0141
MAC640-2B	0,0161
MAC650-2B	0,0185
MAC660-2B	0,0195

Dynamic momentum of the motor <i>Moment dynamique moteur</i> <b>Momento dinamico motore</b>	
Motor type <i>Moteur type</i> <b>Motore tipo</b>	J=1/4 PD <sup>2</sup> [kgm <sup>2</sup> ]
MC405M	0,00006
MC4075M	0,00006
MC41M	0,00008
MCH415M	0,00013
MCH42M	0,00017
MCH43M	0,000775
MCK42M	0,00017
MCK43M	0,000775
MCK455M	0,0011
MC405	0,00005
MC4075	0,00006
MC41	0,00006
MCH415	0,0001
MCH42	0,00013
MCH43	0,00017
MCH44	0,00065
MCH455	0,0007
MCK42	0,00013
MCK43	0,00017
MCR410	0,00132
MCR44	0,00065
MCR455	0,00085
MCR475	0,0010

Feeding cables  
Câbles d'alimentation  
Cavi di alimentazione

Calculation of cross-section  
Calcul de la section  
Calcolo della sezione

The choice of the feeding cable is made considering:

1. acceptable voltage drop
2. power loss in the cable
3. maximum current admitted by the cable.

Le choix du câble d'alimentation s'effectue sur la base:

1. de la chute de tension admissible
2. de la perte de puissance dans la longueur considérée
3. de l'intensité maximale admissible dans le câble.

La scelta del cavo di alimentazione si effettua sulla base:

1. della caduta di tensione ammissibile
2. della potenza dissipata lungo il cavo
3. della corrente massima ammissibile nel cavo.

1.1. Voltage drop  $\Delta U$  [%] in three-wire cables (resistance only)  
*Chute de tension  $\Delta U$  [%] pour câbles tripolaires (résistance seulement)*  
**Caduta di tensione  $\Delta U$  [%] per cavi tripolari (sola resistenza)**

1.1.1. 3-phase motor with - *Moteur triphasé avec* - **Motore trifase con** :  
Starting: direct, by statoric impedences, by autotransformer  
*Démarrage: direct, à impédances statoriques, avec auto-trasformateur*  
**Avviamento: diretto, a impedenze statoriche, con autotrasformatore**

1 three-wire cable 3 x s  
1 câble trois fils 3 x s  
1 cavo tripolare 3 x s

$$\Delta U = \frac{I \cdot L \cdot \cos \varphi}{s \cdot 32,3} + \frac{100}{U} : s = \frac{I \cdot L \cdot \cos \varphi}{\Delta U \cdot 32,3} + \frac{100}{U}$$

1.1.2. 3-phase motor with - *Moteur triphasé avec* - **Motore trifase con** :  
Starting: star-delta  
*Démarrage: étoile-triangle*  
**Avviamento: stella-triangolo**

2 three-wire cable 3 x s  
2 câbles trois fils 3 x s  
2 cavi tripolari 3 x s

$$\Delta U = \frac{I \cdot L \cdot \cos \varphi}{s \cdot 48,5} + \frac{100}{U} : s = \frac{I \cdot L \cdot \cos \varphi}{\Delta U \cdot 48,5} + \frac{100}{U}$$

1.1.3. Single-phase motor  
*Moteur monophasé*  
**Motore monofase**

1 three-wire cable 3 x s  
1 câble trois fils 3 x s  
1 cavo tripolare 3 x s

$$\Delta U = \frac{I \cdot L \cdot \cos \varphi}{s \cdot 28} + \frac{100}{U} : s = \frac{I \cdot L \cdot \cos \varphi}{\Delta U \cdot 28} + \frac{100}{U}$$

1.2. Voltage drop  $\Delta U$  [%] in single-wire cables (resistance and reactance)  
*Chute de tension  $\Delta U$  [%] pour câbles unipolaires (résistance et réactance)*  
**Caduta di tensione  $\Delta U$  [%] per cavi unipolari (resistenza e reattanza)**

$$\Delta U = 1,73 \cdot I \cdot L \cdot (R \cdot \cos \varphi + X \cdot \sin \varphi) \cdot \frac{100}{U}$$

1.2.1. The voltage drop changes according to the resistance and the reactance induced by single-wires each other according to:  
- the cables cross section  
- their respective position (single, paired, side by side)  
- their angular position (at 120° at 180°)

*La chute de tension varie en fonction de la résistance et de la réactance d'induction causée par les conducteurs entre eux et en fonction de:*  
- la section des câbles  
- la position entre eux (single, jumelés côte à côte)  
- leur position angulaire (à 120° à 180°)

**La caduta di tensione varia in funzione della resistenza e della reattanza induttiva esercitata reciprocamente dai singoli conduttori in funzione:**  
- della dimensione dei cavi  
- della loro posizione reciproca (singoli, abbinati, affiancati)  
- della loro disposizione angolare (a 120° a 180°)

1.3. For different supply voltages:  
*Pour tensions d'alimentation différentes:*  
**Per tensioni di alimentazione diverse:**

$$L_N = L \cdot \frac{U_N}{230} : L_N = L \cdot \frac{U_N}{400}$$

1.4. For different power factors:  
*Pour cosφ différents:*  
**Per cosφ diversi:**

$$L_N = L \cdot \frac{0,8}{\cos \varphi}$$

2.1. Power loss  $P_v$  along the feeding cables  
*Perte de puissance  $P_v$  le long des câbles d'alimentation*  
**Perdita di potenza  $P_v$  lungo i cavi di alimentazione**

$$P_v = I^2 \cdot \frac{L}{s \cdot 18,7} \text{ [W]}$$

**I** = Motor nominal current [A]  
= *Intensité nominale du moteur [A]*  
= **Assorbimento nominale del motore [A]**

**R** = Cable resistance [ $\Omega$ /m]  
= *Résistance et du câble [ $\Omega$ /m]*  
= **Resistenza del cavo [ $\Omega$ /m]**

**U<sub>N</sub>** = New voltage [V]  
= *Nouvelle tension [V]*  
= **Nuova tensione [V]**

**L** = Cable length [m]  
= *Longueur du câble [m]*  
= **Lunghezza del cavo [m]**

**X** = Inductive reactance [ $\Omega$ /m]  
= *Réactance d'induction [ $\Omega$ /m]*  
= **Reattanza induttiva [ $\Omega$ /m]**

**$\Delta U$**  = Voltage drop [%]  
= *Chute de tension [%]*  
= **Caduta di tensione [%]**

**L<sub>N</sub>** = New cable length [m]  
= *Nouvelle longueur du câble [m]*  
= **Nuova lunghezza cavo [m]**

**U** = Nominal voltage [V]  
= *Tension nominale [V]*  
= **Tensione nominale [V]**

**s** = Copper wire cross-section [mm<sup>2</sup>]  
= *Section du conducteur en cuivre [mm<sup>2</sup>]*  
= **Sezione del conduttore in rame [mm<sup>2</sup>]**

**Cos φ** = Full-load power factor (see table motors operating data)  
= *Facteur de puissance à pleine charge (voir tableau caractéristiques moteurs)*  
= **Fattore di potenza a pieno carico (vedi tabella caratteristiche motori)**



Maximum permitted current  
*Courant maximum admissible*  
 Corrente massima ammissibile

Tree-wire cables EPDM/EPR* insulated 4" <i>Câbles tripolaires isolés en EPDM/EPR* 4"</i> <i>Cavi tripolari isolati in EPDM/EPR* 4"</i>													
Cable cross-section <i>Section du câble</i> <i>Sezione del cavo</i>	[mm <sup>2</sup> ]	1,5	2,5	4	6	10	16						
IMAX maximum allowable current for three-pole cables in [A] <i>Intensité maximale admissible IMAX câbles tripolaires</i> <i>IMAX ammissibile e cavi tripolari</i>	[A]	20	28	37	48	67	90						
Max. operating temperature <i>Température maximum de service</i> <i>Temperatura max di esercizio</i>	[°C]	90	90	90	90	90	90						
For different environmental temperatures apply the multiplication coefficient K: <i>Pour des températures ambiantes différentes appliquer le coefficient multiplicatif K:</i> <b>Per temperature diverse applicare il coefficiente moltiplicativo K:</b>													
Ambient temperature <i>Température ambiante</i> <i>Temperatura ambiente</i>	[°C]	10	15	20	25	30	35	40	45	50			
In the open air <i>A l'air libre</i> <i>In aria libera</i>	K	1,15	1,12	1,08	1,04	1	0,96	0,91	0,87	0,82			

The maximum allowable current values refer to cables in free air at 30°C ambient temperature.

If the installation conditions are different, multiply the maximum allowable current value in the table by coefficient:

0.83 if the cables are ducted in air;

0.7 if the cables are buried in the ground (soil temperature 20°C)

\* Cables in EPDM/EPR are certified for contact with drinking water in accordance with the following regulations: WRAS (Water Regulations Advisory Scheme) according to BS 6920; ACS (Attestation de Conformité Sanitaire) according to DGS/VS4 99/217 and DGS/VS4 2000/232; Ministerial Decree D.M. 174/04

*Les caractéristiques de l'intensité maximale admissible se réfèrent à des câbles posés à l'air libre à une température ambiante de 30°C.*

*En cas de conditions de pose différentes, multiplier l'intensité maximale admissible du tableau par le coefficient :*

*0,83 en cas de pose sous tube à l'air libre ;*

*0,7 en cas de pose enterrée (température du sol 20°C)*

\* *Les câbles en EPDM/EPR sont certifiés au contact avec l'eau potable, conformément aux normes : WRAS (Water Regulations Advisory Scheme) suivant la BS 6920 ; ACS (Attestation de Conformité Sanitaire) suivant les circulaires DGS/VS4 99/217 et DGS/VS4 2000/232 ; D.M. 174/04*

I dati di corrente massima ammissibile sono riferiti ad una posa dei cavi in aria libera a temperatura ambiente di 30°C. Per

condizioni di posa differenti, moltiplicare la corrente massima ammissibile di tabella per il coefficiente:

0,83 in caso di posa in tubo in aria;

0,7 in caso di posa interrata (temperatura terreno 20°C)

\* I cavi in EPDM/EPR sono certificati al contatto con l'acqua potabile, ai sensi delle normative: WRAS (Water Regulations Advisory Scheme) secondo la BS 6920; ACS (Attestation de Conformité Sanitaire) secondo le DGS/VS4 99/217 e DGS/VS4 2000/232; D.M. 174/04.

Maximum permitted current  
*Courant maximum admissible*  
**Corrente massima ammissibile**

Tree-wire cables PVC insulated 4" <i>Câbles tripolaires isolés en PVC 4"</i> <b>Cavi tripolari isolati in PVC 4"</b>														
Cable cross-section <i>Section du câble</i> <b>Sezione del cavo</b>	[mm <sup>2</sup> ]	1,5	2,5	4	6	10	16							
IMAX maximum allowable current for three-pole cables in [A] <i>Intensité maximale admissible IMAX câbles tripolaires</i> <b>IMAX ammissibile cavi tripolari</b>	[A]	16	22	30	38	54	72							
Max. operating temperature <i>Température maximum de service</i> <b>Temperatura max di esercizio</b>	[°C]	70	70	70	70	70	70							

For different environmental temperatures apply the multiplication coefficient K:  
*Pour des températures ambiantes différentes appliquer le coefficient multiplicatif K:*  
**Per temperature diverse applicare il coefficiente moltiplicativo K:**

Ambient temperature <i>Température ambiante</i> <b>Temperatura ambiente</b>	[°C]	10	15	20	25	30	35	40	45	50				
In the open air <i>A l'air libre</i> <b>In aria libera</b>	K	1,22	1,17	1,12	1,06	1	0,94	0,87	0,79	0,71				

The maximum allowable current values refer to cables in free air at 30°C ambient temperature.  
 If the installation conditions are different, multiply the maximum allowable current value in the table by coefficient:  
 0,78 if the cables are ducted in air;  
 0,76 if the cables are buried in the ground (soil temperature 20°C)

*Les caractéristiques de l'intensité maximale admissible se réfèrent à des câbles posés à l'air libre à une température ambiante de 30°C.*  
*En cas de conditions de pose différentes, multiplier l'intensité maximale admissible du tableau par le coefficient :*  
*0,78 en cas de pose sous tube à l'air libre ;*  
*0,76 en cas de pose enterrée (température du sol 20°C)*

**I dati di corrente massima ammissibile sono riferiti ad una posa dei cavi in aria libera a temperatura ambiente di 30°C. Per condizioni di posa differenti, moltiplicare la corrente massima ammissibile di tabella per il coefficiente:**  
**0,78 in caso di posa in tubo in aria;**  
**0,76 in caso di posa interrata (temperatura terreno 20°C)**

Maximum permitted current  
 Courant maximum admissible  
 Corrente massima ammissibile

Tree-wire cables PVC/EPDM* insulated 6" Câbles tripolaires isolés en PVC/EPDM* 6" Cavi tripolari isolati in PVC/EPDM* 6"															
Cable cross-section 3 x s Section du câble 3 x s Sezione del cavo 3 x s	[mm <sup>2</sup> ]	1,5	2,5	4	6	10	16	25	35	50	70	95	120	150	185
In the open air at 30 °C A l'air libre à 30 °C In aria libera a 30 °C	[A]	20	28	37	48	67	90	90	142	172	221	268	311	359	410
Max. operating temperature Température maximum de service Temperatura max di esercizio	[°C]	70	70	70	70	70	70	70	70	70	70	70	70	70	70
For different environmental temperatures apply the multiplication coefficient K: Pour des températures ambiantes différentes appliquer le coefficient multiplicatif K: Per temperature diverse applicare il coefficiente moltiplicativo K:									Tree-wire cables PVC/EPDM* insulated Câbles tripolaires isolés en PVC/EPDM* Cavi tripolari isolati in PVC/EPDM*						
Ambient temperature Température ambiante Temperatura ambiente	[°C]	10	15	20	25	30	35	40	45	50	70	70	70	70	70
In the open air A l'air libre In aria libera	K	1,22	1,17	1,12	1,06	1	0,94	0,87	0,79	0,71	70	70	70	70	70

If two 3-core cables, multiply the max. permitted current detailed in the chart by the coefficient:  
 2 with direct or stator starting  
 1,73 with star-delta starting

\* The EPDM cables are fit for contact with drinking water, certified by WRAS (Water Regulations Advisory Scheme) in compliance with standard BS 6920.

En utilisant deux câbles tripolaires, multiplier le courant maximum admissible du tableau par le coefficient:  
 2 pour démarrage direct ou par stator  
 1,73 pour démarrage étoile-triangle

\* Les câbles en EPDM sont indiqués pour le contact avec l'eau potable, certifiés par le WRAS (Water Regulations Advisory Scheme) conformément à la réglementation BS 6920.

N.B. Impiegando due cavi, moltiplicare la corrente massima ammissibile di tabella per il coefficiente:  
 2 con avviamento diretto o statorico  
 1,73 con avviamento stella-triangolo

\* I cavi in EPDM sono idonei al contatto con l'acqua potabile, certificati dal WRAS (Water Regulations Advisory Scheme) secondo la normativa BS 6920

Maximum permitted current  
 Courant maximum admissible  
 Corrente massima ammissibile

Single-core cables isolated with EPDM* 6" Câbles unipolaires isolés en EPDM* 6" Cavi unipolari isolati in EPDM* 6"														
Cable cross-section 1 x s Section du câble 1 x s Sezione del cavo 1 x s	[mm <sup>2</sup> ]	2,5	4	6	10	16	25	35	50	70	95	120	150	185
In the open air at 30 °C A l'air libre à 30 °C In aria libera a 30 °C	[A]	29	40	52	72	96	126	158	194	251	307	360	417	479
Max. operating temperature Température maximum de service Temperatura max di esercizio	[°C]	70	70	70	70	70	70	70	70	70	70	70	70	70
For different environmental temperatures apply the multiplication coefficient K: Pour des températures ambiantes différentes appliquer le coefficient multiplicatif K: Per temperature diverse applicare il coefficiente moltiplicativo K:										Single-core cables isolated with EPDM* Câbles unipolaires isolés en EPDM* Cavi unipolari isolati in EPDM*				
Ambient temperature Température ambiante Temperatura ambiente	[°C]	10	15	20	25	30	35	40	45	50	70	70	70	70
In the open air A l'air libre In aria libera	K	1,22	1,17	1,12	1,06	1	0,94	0,87	0,79	0,71	70	70	70	70

If two 3-core cables, multiply the max. permitted current detailed in the chart by the coefficient:  
 2 with direct or stator starting (cables in parallel)  
 1,73 with star-delta starting

*En utilisant deux câbles tripolaires, multiplier le courant maximum admissible du tableau par le coefficient:  
 2 pour démarrage direct ou par stator (câbles en parallèle)  
 1,73 pour démarrage étoile-triangle*

*\* Les câbles en EPDM sont indiqués pour le contact avec l'eau potable, certifiés par le WRAS (Water Regulations Advisory Scheme) conformément à la réglementation BS 6920.*

**N.B. Impiegando due cavi, moltiplicare la corrente massima ammissibile di tabella per il coefficiente:  
 2 con avviamento diretto o statorico (cavi in parallelo)  
 1,73 con avviamento stella-triangolo**

**\* I cavi in EPDM sono idonei al contatto con l'acqua potabile, certificati dal WRAS (Water Regulations Advisory Scheme) secondo la normativa BS 6920**

\* The EPDM cables are fit for contact with drinking water, certified by WRAS (Water Regulations Advisory Scheme) in compliance with standard BS 6920.

Max admitted length  
Longueur maxi admise  
Lunghezze massime ammissibili

3-core EPDM/EPR o PVC* power cables Câbles d'alimentation tripolaires en EPDM/EPR o PVC* Cavi di alimentazione tripolari in EPDM/EPR o PVC*													
Nominal current Intensité nominale Corrente nominale	Tension Tension Tensione	Cable cross-section 3 (4) x ..... [mm <sup>2</sup> ] Câble de section 3 (4) x ..... [mm <sup>2</sup> ] Cavo di sezione 3 (4) x ..... [mm <sup>2</sup> ]											
		1,5	2,5	4	6	10	16	1,5	2,5	4	6	10	16
I [A]	U [V]	Max Length ..... [m] Longueur maxi ..... [m] Lunghezza max ..... [m]											
		Single-phase 4" Monophasés 4" Monofase 4"						Three-phase 4" Triphasés 4" Motori trifase 4"					
1	230	284	470					328	543				
	400							570					
1.5	230	189	313	503				218	362	580			
	400							380					
2	230	142	235	377	566			164	271	435			
	400							285	472				
2.5	230	113	188	302	452			131	217	348	522		
	400							228	377				
3	230	95	157	251	377			109	181	290	435		
	400							190	315	505			
4	230	71	117	188	283	459		82	136	218	327	530	
	400							142	236	379	568		
5	230	57	94	151	226	367	574	66	109	174	261	424	
	400							114	189	303	454		
6	230	47	78	126	189	306	478	55	90	145	218	354	552
	400							95	157	252	379		
7	230	41	67	108	162	262	410	47	78	124	187	303	474
	400							81	135	216	324	527	
8	230	35	59	94	141	230	359	41	68	109	163	265	414
	400							71	118	189	284	461	
9	230	32	52	84	126	204	319	36	60	97	145	236	368
	400							63	105	168	252	410	
10	230	28	47	75	113	184	287	33	54	87	131	212	331
	400							57	94	151	227	369	576
11	230	26	43	69	103	167	261	30	49	79	119	193	301
	400							52	86	138	206	335	524
12	230	24	39	63	94	153	239	27	45	73	109	177	276
	400							47	79	126	189	307	480
13	230	22	36	58	87	141	221	25	42	67	100	163	255
	400							44	73	116	175	284	443
14	230	20	34	54	81	131	205	23	39	62	93	152	237
	400							41	67	108	162	264	412
15	230	19	31	50	75	122	191	22	36	58	87	141	221
	400							38	63	101	151	246	384
16	230	18	29	47	71	115	179	20	34	54	82	133	207
	400							36	59	95	142	231	360
17	230	17	28	44	67	108	169	19	32	51	77	125	195
	400							34	56	89	134	217	339
18	230	16	26	42	63	102	159	18	30	48	73	118	184
	400							32	52	84	126	205	320
19	230	15	25	40	60	97	151	17	29	46	69	112	174
	400							30	50	80	120	194	303
20	230	14	23	38	57	92	144	16	27	44	65	106	166
	400							28	47	76	114	184	288

The lengths given in boldface type refer solely to cables in EPDM/EPR.

Make sure that the current considered is effectively that absorbed by the motor in the real operating conditions.

The cable lengths refer to 30°C ambient temperature; installation in air; 50Hz frequency; cosj = 0.8 and 3% permissible voltage drop. For other operating conditions, refer to the selection procedure detailed: power cables.

Make sure that the section of the riser cable is the same as the section of the motor output cable, or larger.

Les longueurs marquées en caractères gras se réfèrent aux câbles en EPDM/EPR seulement.

Vérifier que le courant considéré soit effectivement celui absorbé par le moteur dans les conditions réelles de service.

Les longueurs des câbles se réfèrent à une température ambiante de 30°C; pose à l'air libre; alimentation 50Hz; cosj = 0,8 et chute de tension admissible = 3%. Pour des conditions différentes voir la procédure de sélection: Câbles d'alimentation.

Vérifier que la section sélectionnée pour le câble de remontée soit supérieure ou égale à la section du câble de sortie moteur.

Le lunghezze contrassegnate in grassetto sono riferite solo ai cavi in EPDM/EPR.

Assicurarsi che la corrente considerata sia effettivamente quella assorbita dal motore nelle condizioni reali d'esercizio.

Le lunghezze dei cavi sono riferite ad una temperatura ambiente di 30°C; installazione in aria; alimentazione 50Hz; cosj = 0,8 e caduta di tensione ammessa = 3%.

Per condizioni diverse, verificare accuratamente i parametri di selezione vedi procedura di selezione: cavi di alimentazione.

Assicurarsi che la sezione selezionata per il cavo di risalita sia maggiore o uguale alla sezione del cavo d'uscita motore.

Max admitted length  
 Longueur maxi admise  
 Lunghezze massime ammissibili

3-core PVC/EPDM* power cables Câbles d'alimentation tripolaires en PVC/EPDM* Cavi di alimentazione tripolari in PVC/EPDM*																	
Direct or statoric starting Demarrage direct ou statorique Avviamento diretto o statorico																	
Nominal current Intensité nominale Corrente nominale	Tension U Tension U Tensione U	Cable cross-section 3 x ..... [mm2] Câble de section 3 x ..... [mm2] Cavo di sezione 3 x ..... [mm2]															
		1,5	2,5	4	6	10	16	25	35	50	70	95					
[A]	[V]	Max Length ..... [m] Longueur maxi ..... [m] Lunghezza max ..... [m]															
1,5	230 400	279 485	464														
2,5	230 400	167 291	279 485	446													
4	230 400	104 182	174 303	279 485	418												
6	230 400	70 121	116 202	186 323	279 485	464											
8	230 400	52 91	87 151	139 242	209 363	348											
10	230 400	42 73	70 121	111 194	167 291	279 485	446										
12	230 400	35 61	58 101	93 162	139 242	232 404	371										
14	230 400	30 52	50 87	80 138	119 208	199 346	318	497									
16	230 400		44 76	70 121	104 182	174 303	279 485	435									
18	230 400		39 67	62 108	93 162	155 269	248 431	387									
20	230 400		35 61	56 97	84 145	139 242	223 388	348	488								
25	230 400			45 78	67 116	111 194	178 310	279 485	390								
30	230 400				56 97	93 162	149 258	232 404	325	464							
35	230 400				48 83	80 138	127 221	199 346	279 485	398							
40	230 400					70 121	111 194	174 303	244 424	348	488						
45	230 400					62 108	99 172	155 269	217 377	310	433						
50	230 400						89 155	139 242	195 339	279 485	390						
60	230 400						74 129	116 202	163 283	232 404	325	441					
70	230 400							99 173	139 242	199 346	279 485	378					
80	230 400							87 151	122 212	174 303	244 424	331					
90	230 400								108 188	155 269	217 377	294					
100	230 400								98 170	139 242	195 339	265 460					
120	230 400									116 202	163 283	221 384					
140	230 400										139 242	189 329					
160	230 400										122 212	165 288					
180	230 400											147 256					
200	230 400											132 230					

Cable lengths refer to an environmental temperature of 30 °C; in air, power factor = 0,8, permitted voltage drop = 3%.  
 For other operating conditions, refer to the selection procedure detailed: power cables.

Les longueurs des câbles se réfèrent à une température ambiante de 30 °C, en air, cosφ = 0,8, chute de tension admise = 3%.  
 Pour des conditions différentes voir la procédure de sélection: Câbles d'alimentation.

Le lunghezze dei cavi sono riferite ad una temperatura ambiente di 30 °C; installazione in aria, cosφ = 0,8 e caduta di tensione ammessa = 3%. Per condizioni diverse, verificare accuratamente i parametri di selezione vedi procedura di selezione: cavi di alimentazione.

\* The EPDM cables are fit for contact with drinking water, certified by WRAS (Water Regulations Advisory Scheme) in compliance with standard BS 6920.

\* Les câbles en EPDM sont indiqués pour le contact avec l'eau potable, certifiés par le WRAS (Water Regulations Advisory Scheme) conformément à la réglementation BS 6920.

\* I cavi in EPDM sono idonei al contatto con l'acqua potabile, certificati dal WRAS (Water Regulations Advisory Scheme) secondo la normativa BS 6920

Max admitted length  
*Longueur maxi admise*  
**Lunghezze massime ammissibili**

Single-core PVC/EPDM* power cables <i>Câbles d'alimentation unipolaires en PVC/EPDM*</i> <b>Cavi di alimentazione unipolari PVC/EPDM*</b>																	
Direct or statoric starting <i>Demarrage direct ou statorique</i> <b>Avviamento diretto o statorico</b>																	
Nominal current <i>Intensité nominale</i> <b>Corrente nominale</b>	Tension U <i>Tension U</i> <b>Tensione U</b>	3 cables cross-section 1 x ..... [mm <sup>2</sup> ] <i>3 câbles de section 1 x ..... [mm<sup>2</sup>]</i> <b>3 cavi di sezione 1 x ..... [mm<sup>2</sup>]</b>															
		10	16	25	35	50	70	95	120	150	185						
[A]	[V]	Max Length ..... [m] <i>Longueur maxi ..... [m]</i> <b>Lunghezza max ..... [m]</b>															
20	230 400	102 178	157 272	235 409	310	397											
25	230 400	82 142	125 218	188 327	248 431	318	420										
30	230 400	68 119	104 182	157 273	207 359	265 461	350	442									
35	230 400	59 102	90 156	134 234	177 308	227 395	300	379	443								
40	230 400	51 89	78 136	118 204	155 269	199 345	263 457	332	387	442							
45	230 400	46 79	70 121	104 182	138 239	177 307	234 406	295	344	393	449						
50	230 400	41 71	63 109	94 164	124 216	159 276	210 366	265 461	310	354	404						
60	230 400		52 91	78 136	103 180	132 230	175 305	221 385	258 449	295	337						
70	230 400		45 78	67 117	89 154	114 197	150 261	190 330	221 385	253 440	288						
80	230 400			59 102	77 135	99 173	131 228	166 288	194 337	221 385	252 439						
90	230 400			52 91	69 120	88 154	117 203	147 256	172 299	197 342	224 390						
100	230 400				62 108	79 138	105 183	133 231	155 269	177 308	202 351						
120	230 400				52 90	66 115	88 152	111 192	129 225	147 256	168 293						
140	230 400					57 99	75 131	95 165	111 192	126 220	144 251						
160	230 400						66 114	83 144	97 168	111 192	126 220						
180	230 400						58 102	74 128	86 150	98 171	112 195						
200	230 400							66 115	77 135	88 154	101 176						
220	230 400							60 105	70 122	80 140	92 160						
240	230 400								65 112	74 128	84 146						
260	230 400								60 104	68 118	78 135						
280	230 400									110	125						
300	230 400										103	117					
320	230 400											110					
340	230 400												103				

Cable lengths refer to an environmental temperature of 30 °C; in air, power factor = 0,8, permitted voltage drop = 3%.  
 For other operating conditions, refer to the selection procedure detailed: power cables.

*Les longueurs des câbles se réfèrent à une température ambiante de 30 °C, en air, cosφ = 0,8, chute de tension admise = 3%.  
 Pour des conditions différentes voir la procédure de sélection: Câbles d'alimentation.*

**Le lunghezze dei cavi sono riferite ad una temperatura ambiente di 30 °C; installazione in aria, cosφ = 0,8 e caduta di tensione ammessa = 3%. Per condizioni diverse, verificare accuratamente i parametri di selezione vedi procedura di selezione: cavi di alimentazione.**

\* The EPDM cables are fit for contact with drinking water, certified by WRAS (Water Regulations Advisory Scheme) in compliance with standard BS 6920.

*\* Les câbles en EPDM sont indiqués pour le contact avec l'eau potable, certifiés par le WRAS (Water Regulations Advisory Scheme) conformément à la réglementation BS 6920.*

**\* I cavi in EPDM sono idonei al contatto con l'acqua potabile, certificati dal WRAS (Water Regulations Advisory Scheme) secondo la normativa BS 6920**

Max admitted length  
 Longueur maxi admise  
 Lunghezze massime ammissibili

Single-core PVC/EPDM* power cables Câbles d'alimentation unipolaires en PVC/EPDM* Cavi di alimentazione unipolari PVC/EPDM*																
Direct or statoric starting Demarrage direct ou statorique Avviamento diretto o statorico																
Nominal current Intensité nominale Corrente nominale	Tension U Tension U Tensione U	6 cables cross-section 1 x ..... [mm <sup>2</sup> ] 6 câbles de section 1 x ..... [mm <sup>2</sup> ] 6 cavi di sezione 1 x ..... [mm <sup>2</sup> ]														
		10	16	25	35	50	70	95	120	150	185					
[A]	[V]	Max Length ..... [m] Longueur maxi ..... [m] Lunghezza max ..... [m]														
20	230 400	205 356	313	470												
25	230 400	164 285	251 436	376	496											
30	230 400	137 237	209 363	313	413											
35	230 400	117 204	179 311	269 467	354	454										
40	230 400	102 178	157 272	235 409	310	397										
45	230 400	91 158	139 242	209 363	275 479	353	467									
50	230 400	82 142	125 218	188 327	248 431	318	420									
60	230 400	68 119	104 182	157 273	207 359	265 461	350	442								
70	230 400	59 102	90 156	134 234	177 308	227 395	300	379	443							
80	230 400	51 89	78 136	118 204	155 269	199 345	263 457	332	387	442						
90	230 400	46 79	70 121	104 182	138 239	177 307	234 406	295	344	393	449					
100	230 400	41 71	63 109	94 164	124 216	159 276	210 366	265 461	310	354	404					
120	230 400		52 91	78 136	103 180	132 230	175 305	221 385	258 449	295	337					
140	230 400		45 78	67 117	89 154	114 197	150 261	190 330	221 385	253 440	288					
160	230 400			59 102	77 135	99 173	131 228	166	194	221	252					
180	230 400			52 91	69 120	88 154	117 203	147 256	172	197	224					
200	230 400				62 108	79 138	105 183	133 231	155 269	177	202					
220	230 400				56 98	72 126	96 166	121 210	141	161	184					
240	230 400				52 90	66 115	88 152	111 192	129	147	168					
260	230 400					61 106	81 141	102 177	119	136	155					
280	230 400					99	131	165	192	220	251					
300	230 400						122	154	180	205	234					
320	230 400						114	144	168	192	220					
340	230 400						108	136	159	181	207					
360	230 400						102	128	150	171	195					
380	230 400							121	142	162	185					
400	230 400							115	135	154	176					
420	230 400							110	128	147	167					
440	230 400							105	122	140	160					
460	230 400								117	134	153					

Cable lengths refer to an environmental temperature of 30 °C; in air, power factor = 0,8, permitted voltage drop = 3%.  
 For other operating conditions, refer to the selection procedure detailed: power cables.

Les longueurs des câbles se réfèrent à une température ambiante de 30 °C, en air, cosφ = 0,8, chute de tension admise = 3%.  
 Pour des conditions différentes voir la procédure de sélection: Câbles d'alimentation.

Le lunghezze dei cavi sono riferite ad una temperatura ambiente di 30 °C; installazione in aria, cosφ = 0,8 e caduta di tensione ammessa = 3%. Per condizioni diverse, verificare accuratamente i parametri di selezione vedi procedura di selezione: cavi di alimentazione.

\* The EPDM cables are fit for contact with drinking water, certified by WRAS (Water Regulations Advisory Scheme) in compliance with standard BS 6920.

\* Les câbles en EPDM sont indiqués pour le contact avec l'eau potable, certifiés par le WRAS (Water Regulations Advisory Scheme) conformément à la réglementation BS 6920.

\* I cavi in EPDM sono idonei al contatto con l'acqua potabile, certificati dal WRAS (Water Regulations Advisory Scheme) secondo la normativa BS 6920



Max admitted length  
*Longueur maxi admise*  
**Lunghezze massime ammissibili**

3-core PVC/EPDM* power cables <i>Câbles d'alimentation tripolaires en PVC/EPDM*</i> <b>Cavi di alimentazione tripolari in PVC/EPDM*</b>																		
Star-delta starting <i>Démarrage étoile-triangle</i> <b>Avviamento stella-triangolo</b>																		
Nominal current <i>Intensité nominale</i> <b>Corrente nominale</b>	Tension U <i>Tension U</i> <b>Tensione U</b>	2 cables cross-section 3 x ..... [mm <sup>2</sup> ] <i>2 câbles de section 3 x ..... [mm<sup>2</sup>]</i> <b>2 cavi di sezione 3 x ..... [mm<sup>2</sup>]</b>																
		1,5	2,5	4	6	10	16	25	35	50	70	95						
[A]	[V]	Max Length ..... [m] <i>Longueur maxi ..... [m]</i> <b>Lunghezza max ..... [m]</b>																
8	230 400	78 136	131 227	209 364	314													
10	230 400	63 109	105 182	167 291	251 437	418												
12	230 400	52 91	87 152	139 243	209 364	349												
14	230 400	45 78	75 130	120 208	179 312	299	478											
16	230 400	39 68	65 114	105 182	157 273	261 455	418											
18	230 400	35 61	58 101	93 162	139 243	232 404	372											
20	230 400	31 55	52 91	84 146	125 218	209 364	335											
25	230 400	25 44	42 73	67 116	100 175	167 291	268 466	418										
30	230 400		35 61	56 97	84 146	139 243	223 388	349	488									
35	230 400		30 52	48 83	72 125	120 208	191 333	299	418									
40	230 400		26 45	42 73	63 109	105 182	167 291	261 455	366									
45	230 400			37 65	56 97	93 162	149 259	232 404	325	465								
50	230 400			33 58	50 87	84 146	134 233	209 364	293	418								
60	230 400				42 73	70 121	112 194	174 303	244 424	349	488							
70	230 400				36 62	60 104	96 166	149 260	209 364	299	418							
80	230 400					52 91	84 146	131 227	183 318	261 455	366	497						
90	230 400					46 81	74 129	116 202	163 283	232 404	325	442						
100	230 400						67 116	105 182	146 255	209 364	293	397						
120	230 400							56 97	87 152	122 212	174 303	244 424	331					
140	230 400								75 130	105 182	149 260	209 364	284 494					
160	230 400								65 114	92 159	131 227	183 318	248 432					
180	230 400									81 141	116 202	163 283	221 384					
200	230 400									73 127	105 182	146 255	199 346					
220	230 400										95 165	133 231	181 314					
240	230 400										87 152	122 212	166 288					
260	230 400										80 140	113 196	153 266					
280	230 400											105 182	142 247					

Cable lengths refer to an environmental temperature of 30 °C; in air, power factor = 0,8, permitted voltage drop = 3%.  
 For other operating conditions, refer to the selection procedure detailed: power cables.

*Les longueurs des câbles se réfèrent à une température ambiante de 30 °C, en air, cosφ = 0,8, chute de tension admise = 3%.  
 Pour des conditions différentes voir la procédure de sélection: Câbles d'alimentation.*

Le lunghezze dei cavi sono riferite ad una temperatura ambiente di 30 °C; installazione in aria, cosφ = 0,8 e caduta di tensione ammessa = 3%. Per condizioni diverse, verificare accuratamente i parametri di selezione vedi procedura di selezione: cavi di alimentazione.

\* The EPDM cables are fit for contact with drinking water, certified by WRAS (Water Regulations Advisory Scheme) in compliance with standard BS 6920.

*\* Les câbles en EPDM sont indiqués pour le contact avec l'eau potable, certifiés par le WRAS (Water Regulations Advisory Scheme) conformément à la réglementation BS 6920.*

\* I cavi in EPDM sono idonei al contatto con l'acqua potabile, certificati dal WRAS (Water Regulations Advisory Scheme) secondo la normativa BS 6920

Generator power  
 Puissance du générateur  
 Potenza del generatore

When an electric generator has to be used to supply the motor, it should be carefully selected.  
 A chart is provided giving the minimum rating in kW and kVA of the generators used to supply the motors.

*Dans le cas d'utilisation d'un générateur électrique pour alimenter le moteur, le choix doit être avisé.  
 Nous fournissons un tableau indicatif des puissances minimum en kW et en kVA des générateurs pour l'alimentation des moteurs électriques*

**Quando si deve utilizzare un generatore elettrico per l'alimentazione del motore, è necessaria un' oculata scelta.  
 Forniamo una tabella indicativa delle potenze minime in kW ed in kVA dei generatori per l'alimentazione dei motori elettrici.**

Electric motor power Puissance moteur électrique Potenza motore elettrico		Generator power Puissance du générateur Potenza del generatore	
		Direct starting Démarrage direct Avviamento diretto	
[kW]	[HP]	[kW]	[kVA]
2.2	3	6	7.5
3	4	8	10
4	5,5	10	12,5
5,5	7,5	12,5	15,6
7,5	10	15	18,8
9,2	12,5	18,8	23,5
11	15	22,5	28
13	17,5	26,4	33
15	20	30	38
18,5	25	40	50
22	30	45	57
26	35	52	65
30	40	60	75
37	50	75	94
45	60	90	112
51	70	105	131
59	80	120	150
66	90	135	170
75	100	150	190
92	125	185	230
110	150	210	260

Electric motor power Puissance moteur électrique Potenza motore elettrico		Generator power Puissance du générateur Potenza del generatore	
		Star-delta starting Démarrage étoile-triangle Avviamento stella-triangolo	
[kW]	[HP]	[kW]	[kVA]
-	-	-	-
3	4	6	7,5
4	5,5	8	10
5,5	7,5	10,8	13,5
7,5	10	14	17,5
9,2	12,5	17,2	21,5
11	15	20,5	25,5
13	17,5	23,6	29,5
15	20	27	34
18,5	25	33	42
22	30	40	50
26	35	45	57
30	40	52	65
37	50	65	81
45	60	77	97
51	70	90	112
59	80	102	128
66	90	115	144
75	100	128	160
92	125	158	198
110	150	190	237

VALUES VALEURS GRANDEZZA		ALTERNATING CURRENT COURANT ALTERNATIF CORRENTE ALTERNATA	
		SINGLE-PHASE MONOPHASE MONOFASE	THREE-PHASE TRIPHASE TRIFASE
Absorbed power (active) <i>Puissance absorbée (active)</i> Potenza assorbita (attiva)	[kW]	$P_a = \frac{U \cdot I \cdot \cos \varphi}{1000}$	$P_a = \frac{1,73 \cdot U \cdot I \cdot \cos \varphi}{1000}$
Yield power <i>Puissance utile</i> Potenza resa	[kW]	$P_r = \frac{U \cdot I \cdot \cos \varphi \cdot \eta_M}{1000}$	$P_r = \frac{1,73 \cdot U \cdot I \cdot \cos \varphi \cdot \eta_M}{1000}$
Absorbed current <i>Courant absorbé</i> Corrente assorbita	[A]	$I = \frac{P_r \cdot 1000}{U \cdot \cos \varphi \cdot \eta_M}$	$I = \frac{P_r \cdot 1000}{1,73 \cdot U \cdot \cos \varphi \cdot \eta_M}$
Power factor (cos φ) <i>Facteurs de puissance (cos φ)</i> Fattore di potenza (cos φ)	[0,.....]	$\cos \varphi = \frac{P_a \cdot 1000}{U \cdot I}$	$\cos \varphi = \frac{P_a \cdot 1000}{1,73 \cdot U \cdot I}$
Nominal torque <i>Couple nominal</i> Coppia nominale	[Nm]	$M_N = \frac{P_r \cdot 1000}{0,105 \cdot n}$	
Motor efficiency <i>Rendement du moteur</i> Rendimento motore	[%]	$\eta_M = \frac{P_r}{P_a} \cdot 100$	
Synchronous speed <i>Vitesse de synchronisme</i> Velocità sincrona	[n <sup>-1</sup> ]	$n_s = \frac{f \cdot 120}{\text{No. Poli} / \text{Poles} / \text{Pôles}}$	
Sliding <i>Glissement</i> Scorrimento	[%]	$S = \frac{n_s - n}{n_s} \cdot 100$	

Electrical tolerances  
*Tolérances électriques*  
**Tolleranze elettriche**

Tolerances on the guaranteed values of the electrical characteristics of asynchronous motors as per CEI norms in accordance with IEC norms.

*Tolérances sur les valeurs garanties des caractéristiques électriques des moteurs asynchrones selon les Normes CEI en accord avec les Normes IEC.*

**Tolleranze sui valori garantiti delle caratteristiche elettriche dei motori asincroni, secondo Norme CEI in accordo con le Norme IEC.**

VALUE VALEURS GRANDEZZA		TOLERANCE TOLERANCE TOLLERANZA
Real efficiency <i>Rendement réel</i> Rendimento effettivo	[η]	$-0,15 \cdot (1 - \eta_{\phi})$ [%]
Power factor <i>Facteur de puissance</i> Fattore di potenza	[cos φ]	$-\frac{1}{6} \cdot (1 - \cos \varphi)$ <span style="font-size: small;">[nim: 0,02 max: 0,07]</span>
Sliding <i>Glissement</i> Scorrimento	[S]	± 20%

VALUE VALEURS GRANDEZZA		TOLERANCE TOLERANCE TOLLERANZA
Maximum torque <i>Couple maximal</i> Coppia massima	[M <sub>M</sub> ]	- 10% (min 1,6 M <sub>N</sub> ) [Nm]
Starting torque <i>Couple de démarrage</i> Coppia di spunto	[M <sub>S</sub> ]	+ 25% - 15%
Starting current <i>Intensité de démarrage</i> Corrente di spunto	[I <sub>S</sub> ]	+ 20% [A]

Asynchronous motors absorb, from the main, "apparent" electrical power which is partly "active" power, and partly "reactive" power; the latter is used for motor magnetization and cannot be technically eliminated.

The ratio of "active power" to "apparent power" forms the "power factor" or  $\cos \varphi$ .

The absorbed reactive power on the line can be reduced, according with the current rules, modifying the phase displacement between absorbed current and supply tension.

Everything must be realised using an appropriate power capacitors battery.

*Les moteurs asynchrones absorbent sur le réseau une puissance électrique "apparente" constituée en partie d'une puissance "active" et en partie d'une puissance "réactive".*

*Cette dernière sert à la magnétisation du moteur et ne peut pas être techniquement supprimée.*

*Le rapport entre "puissance active" et "puissance apparente" constitue le "facteur de puissance" ou  $\cos \varphi$ .*

*La puissance réactive absorbée sur la ligne peut être réduite, selon les normes en vigueur, en modifiant le déphasage entre courant absorbé et tension d'alimentation.*

*Ceci devra être réalisé en utilisant une adéquate batterie des condensateurs de puissance.*

I motori asincroni assorbono dalla rete potenza elettrica "apparente" costituita in parte da potenza "attiva" ed in parte da potenza "reattiva"; quest'ultima serve alla magnetizzazione del motore e non può essere tecnicamente soppressa.

Il rapporto fra "potenza attiva" e "potenza apparente" costituisce il "fattore di potenza", o  $\cos \varphi$ .

La potenza reattiva assorbita sulla linea può essere ridotta, in base alle norme vigenti, modificando lo sfasamento tra corrente assorbita e la tensione di alimentazione. Ciò dovrà essere realizzato utilizzando opportuna batteria di condensatori di potenza.

Nomogram for determining  $P_c$  power [kVAR] of phase-shift capacitors  
 Nomogramme pour la détermination de la puissance  $P_c$  [kVAR] des condensateurs de rattrapage.  
 Nomogramma per la determinazione della potenza  $P_c$  [kVAR] dei condensatori di rifasamento.

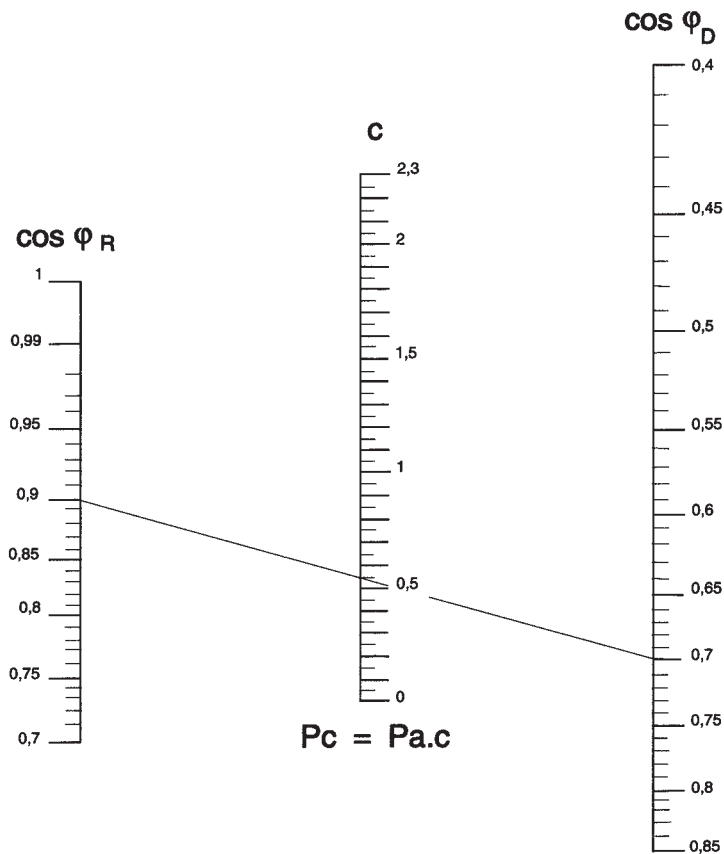

**Example:**  
 Electrical input (active)  $P_a$  motor = 20 kW  
 Available power factor  $\cos \varphi_D = 0,7$   
 Required power factor  $\cos \varphi_R = 0,9$   
 Multiplying factor (from nomogram)  $c = 0,54$   
 Phase-shift capacitor power  $P_c$   
 $P_c = P_a \times c = 20 \times 0,54 = 10,8$  kVAR

**Exemples:**  
 Puissance absorbée (active) du moteur  $P_a = 20$  kW  
 Factor de puissance disponible  $\cos \varphi_D = 0,7$   
 Factor de puissance recherchée  $\cos \varphi_R = 0,9$   
 Facteur multiplicatif (du nomogramme)  $c = 0,54$   
 Puissance des condensateurs  $P_c$   
 $P_c = P_a \times c = 20 \times 0,54 = 10,8$  kVAR

**Esempio:**  
 Potenza attiva motore  $P_a = 20$  kW  
 Fattore di potenza disponibile  $\cos \varphi_D = 0,7$   
 Fattore di potenza richiesto  $\cos \varphi_R = 0,9$   
 Fattore moltiplicativo da nomogramma  $c = 0,54$   
 Potenza del condensatore di rifasamento  $P_c$   
 $P_c = P_a \times c = 20 \times 0,54 = 10,8$  kVAR

Accessories  
Accessoires  
Accessori

DCL Low level safety device

*DCL Dispositif pour défaut d'eau et contrôle niveau*

**DCL Dispositivo contro la marcia a secco e controllo del livello**

The conductivity electronic device DCL, is used for monitoring the levels of conductive liquids in wells, tanks or reservoirs.

In the case of minimum and maximum level control (prevention of dry running and automatic reset of the electric pump), the relay is at rest until the liquid reaches the upper level.

At this point the relay starts working thereby exciting the remote control switch coil (causing the electric pump to start and keeps this state until the liquid drows down below the minimum level.

During minimum level checking (prevention of dry running) relay remains constantly excited if pumped liquids is available.

Relay is not excited when there is no liquid or voltage lacks.

If so, relay must be manually reset.

*Le dispositif électroniques à conductivité DCL, sert à relever ou à contrôler les niveau du liquide conducteur dans les puits, les baches ou les réservoirs.*

*En cas de contrôle du niveau minimum ou maximum (protection contre la marche à sec et remise en marche automatique de l'électropompe), le relais se maintient en situation de repos tant que le liquide n'a pas atteint le niveau supérieur. A ce point, le relais excite la bobine du telerupteur (qui provoque le démarrage de l'électropompe) et la maintient jusqu'à ce que le liquide descend sous le niveau minimum.*

*Quand on va vérifier le niveau minimum (protection contre la marche à sec) le relais reste toujours excité en présence du liquide pompé. Il n'est pas excité en absence du liquide ou quand la tension manque. Dans cette occasion le relais doit être rearmé manuellement.*

**I dispositivo elettronico a conduttività DCL, serve a rilevare o controllare i livelli dei liquidi conduttivi in pozzi, vasche o serbatoi.**

**Nel caso di controllo di minimo e massimo livello (protezione contro la marcia a secco e riavviamento automatico della elettropompa), il relè si mantiene in stato di riposo fintanto che il liquido non ha raggiunto il livello superiore.**

**A questo punto, il relè entra in conduzione eccitando la bobina del teleruttore (che provoca, tramite l'apparecchiatura elettrica, l'avviamento dell'elettropompa) e mantiene tale stato finchè il liquido non scende sotto in livello minimo.**

**Nel caso di semplice controllo di minimo livello (protezione contro la marcia a secco), il relè rimane costantemente eccitato in presenza del liquido diseccitandosi in assenza di questo o per mancanza di tensione e deve essere riarmato manualmente.**

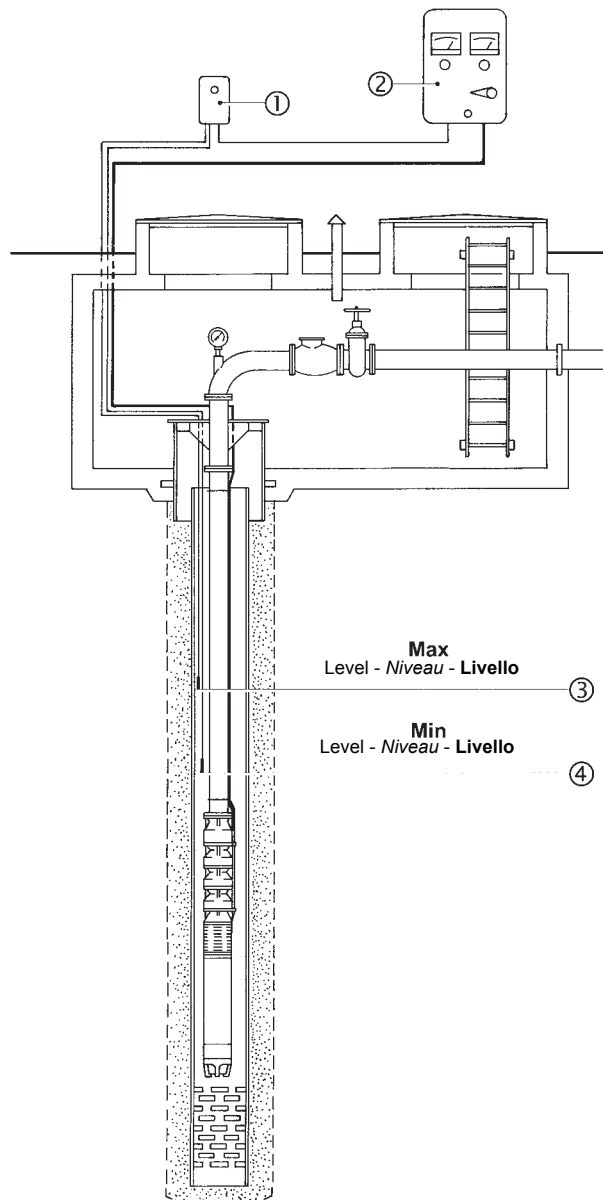

- 1) Low level safety device
- 2) Electric equipment
- 3) Maximum level electric probe
- 4) Minimum level electric probe

- 1) Dispositif complet pour défaut d'eau
- 2) Appareillage électrique
- 3) Sondes électriques au max. de niveau
- 4) Sondes électriques au min. de niveau

- 1) Dispositivo contro la marcia a secco
- 2) Apparecchiatura elettrica
- 3) Sonda elettrica max. livello
- 4) Sonda elettrica min. livello

T-412 Temperature monitoring device for submersed electric motors  
T-412 Appareillage de contrôle de la température des moteurs électriques immergés  
T-412 Apparechiatura di controllo temperatura motori elettrici sommersi

T412 monitors the temperature inside the electric motor.

Connected to the PT100 probe (housed in the electric motor), it is able to read operating temperatures from 0-200°C.  
T412 is supplied without a setting.

How to make the setting:

- Start the electric pump and set it to the operating point with the highest power input. The internal temperature will rise progressively and will be monitored by the probe. When it has reached full rate (this may take up to 2 hours, depending on the motor), the temperature reading will stabilize.
- Once the temperature has become stable, select a value equal to the temperature reading +3°C for the first alarm setting. The alarm must record the excess temperature so as to produce documentation upon the first inspection;
- The setting for the second alarm, which must stop the motor, must equal the temperature reading +6°C; the excess temperature recording can be automatic, but must occur with a delay of at least 15 minutes from the stopping action or when the internal temperature of the motor is 20°C less than the alarm temperature setting;  
ACTIVATION OF THE 2nd ALARM, WHICH STOPS THE MOTOR, WILL OCCUR WHEN:
  - There is an overload
  - There is a poor cooling action
  - There are too frequent starts

With the motor rotor wound in:

- In PVC, the maximum temperature setting of the second alarm must be 58°C
- In PE2+PA, the maximum temperature setting of the second alarm must be 75°C.  
This device can also be used for monitoring the temperature of bearings, lubricants, in surface electric motors and machinery in general.  
The device complies with electromagnetic compatibility standards CEI EN-50081-2 and 50082-2.  
Dimensions: 48\*96 mm DIN 43700  
depth:130 mm.

L'appareillage T412 sert à contrôler la température interne du moteur électrique.

Branché à la sonde PT100 (logée à l'intérieur du moteur électrique) il permet la lecture de la température de fonctionnement entre 0-200°C.  
L'appareillage T412 est fourni sans réglage.

Mode de réglage :

- Mettre l'électropompe en marche et se placer dans le point de travail où la puissance absorbée est la plus élevée, la température interne augmentera progressivement et sera relevée par la sonde. Au régime établi (deux heures peuvent s'écouler, suivant le type de moteur) la température lue se stabilisera.
- Quand la température est stable, régler la première alarme à une valeur égale à la température lue +3°C, l'alarme doit enregistrer le dépassement pour en faire l'acquisition au premier contrôle;
- La deuxième alarme, qui doit commander l'arrêt du moteur, devra être étalonnée à une valeur égale à la température lue +6°C; le redémarrage, avec enregistrement du dépassement, peut être automatique mais doit avoir lieu avec un retard, par rapport à l'arrêt, d'au moins 15 minutes ou à une température interne du moteur inférieure de 20°C par rapport à la température de réglage de l'alarme.  
L'INTERVENTION DE LA 2e ALARME, AVEC ARRÊT DU MOTEUR, SE PRODUIT:
  - En cas de surcharge ;
  - En cas de refroidissement insuffisant;
  - En cas de démarrages trop fréquents.

Avec moteur à rotor bobiné:

- En PVC, la température maximum de réglage de la deuxième alarme est de 58°C.
- En PE2+PA, la température maximum de réglage de la deuxième alarme est de 75°C.  
Ce dispositif pourra aussi être utilisé pour contrôler les températures des roulements, des lubrifiants, dans les moteurs électriques de surface et dans les machines en général.  
L'appareillage est conforme aux normes de compatibilité électromagnétique CEI EN-50081-2 et 50082-2.  
Dimensions: 48\*96 mm DIN 43700  
profondeur: 130 mm.

L'apparechiatura T412, serve a monitorare la temperatura interna del motore elettrico.

Collegata alla sonda PT100 (alloggiata all'interno del motore elettrico) permette la lettura della temperatura di funzionamento tra 0-200°C .  
L'apparechiatura T412 viene fornita senza il settaggio.

Modalità per il settaggio:

- Avviare l'elettropompa e posizionarsi nel punto di lavoro a maggiore potenza assorbita, la temperatura nel suo interno crescerà progressivamente e verrà monitorata dalla sonda. A regime (a seconda del motore possono trascorrere fino a 2 ore) la temperatura letta si stabilizzerà.
- A lettura stabile della temperatura tarare il primo allarme ad un valore pari alla temperatura letta +3°C, l'allarme deve registrare il superamento per averne documentazione alla prima ispezione;
- Il secondo allarme, che deve comandare l'arresto del motore, dovrà essere tarato ad un valore pari alla temperatura letta +6°C; il riavviamento, con registrazione del superamento, può essere automatico ma deve avvenire con un ritardo dall'arresto di almeno 15 minuti o a una temperatura interna del motore inferiore di 20°C rispetto alla temperatura settata di allarme;  
L'INTERVENTO DEL 2° ALLARME, CON ARRESTO DEL MOTORE, AVVIENE QUANDO :
  - C'è un sovraccarico
  - C'è uno scarso raffreddamento
  - Ci sono frequenti avviamenti

Con il motore avvolto :

- In PVC la massima temperatura di settaggio del secondo allarme potrà essere di 58°C
- In PE2+PA la massima temperatura di settaggio del secondo allarme potrà essere di 75°C.  
Tale dispositivo potrà essere utilizzato anche per monitorare le temperature dei cuscinetti, dei lubrificanti, nei motori elettrici di superficie e nelle macchine operatrici in generale.  
L'apparechiatura rispetta le norme di compatibilità elettromagnetica CEI EN-50081-2 e 50082-2.  
Dimensioni : 48\*96 mm DIN 43700  
profondità: 130 mm.

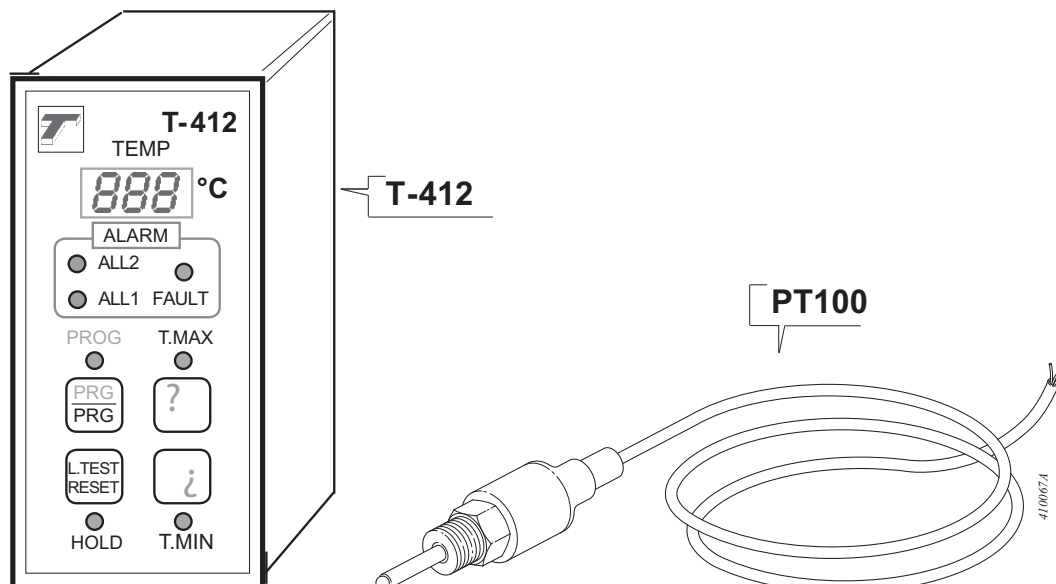

**motralec**

4 rue Lavoisier . ZA Lavoisier . 95223 HERBLAY CEDEX  
Tel. : 01.39.97.65.10 / Fax. : 01.39.97.68.48  
Demande de prix / e-mail : [service-commercial@motralec.com](mailto:service-commercial@motralec.com)  
[www.motralec.com](http://www.motralec.com)

**caprari**