

motralec

4 rue Lavoisier . ZA Lavoisier . 95223 HERBLAY CEDEX

Tel. : 01.39.97.65.10 / Fax. : 01.39.97.68.48

Demande de prix / e-mail : service-commercial@motralec.com

www.motralec.com



Electric Submersible Sewage Pumps
*Electropompes Submersible pour
Eaux Usées*
**Elettropompe Sommergibili
per Acque Reflue**

caprari
pumping power

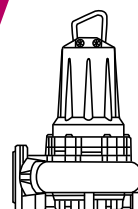

non stop **K+**



HIGH EFFICIENCY ENERGY SAVING

SUBMERSIBLE ELECTRIC PUMPS FOR WASTEWATER

- Extremely sturdy
 - compact
 - highly efficient
 - maximum reliability in heavy duty conditions
 - remarkable energy savings and reductions in maintenance costs
- these are the key features of the *non stop K+* series. Four combined effects in just one electric pump:
- fiber shredding action
 - cleaning action behind impeller
 - anti-sediment action
 - generously sized free passages

ELECTROPOMPES SUBMERSIBLES POUR EAUX USÉES

- *Robustesse extrême*
 - *compacts*
 - *haut rendement*
 - *fiabilité maximale dans des conditions d'utilisation difficiles*
 - *forte économie d'énergie et des coûts d'entretien*
- son les caractéristiques de la série *non stop K+*.
Quatre effets combinés en une seule électropompe:
- *découpe des fibres*
 - *nettoyage à l'arrière de la roue*
 - *anti-sédimentation*
 - *passages libres amples*

ELETTROPOMPE SOMMERSIBILI PER ACQUE REFLUE

- **Estrema robustezza**
 - **compattezza**
 - **alto rendimento**
 - **massima affidabilità in condizioni d'uso gravoso**
 - **forte risparmio energetico e dei costi di manutenzione**
- sono le caratteristiche della serie *non stop K+*.
In una sola elettropompa quattro effetti combinati:
- **taglio fibre**
 - **pulizia retro-girante**
 - **anti-sedimentazione**
 - **ampi passaggi liberi**



**PLANT ENGINEERING
INSTALLATIONS
IMPIANTISTICA**

With our great experience and thorough knowledge of water lifting problems, we are able to offer a pre and after-sales service to help you to choose the right products and solutions in terms of functionality, flexibility and operating economy.

Notre connaissance des problèmes liés au relevage des eaux nous permet de mettre à disposition notre grande expérience et compétence dans l'activité de prévente et après-vente, à travers l'orientation du choix du produit et des solutions les plus appropriées aux besoins précis, sur le plan de la fonctionnalité, de la flexibilité et de l'économie de service.

La profonda conoscenza delle problematiche legate al sollevamento delle acque, ci consente di mettere a disposizione l'esperienza maturata come supporto pre e post vendita, orientando la scelta del prodotto e delle soluzioni più idonee in termini di funzionalità, flessibilità ed economicità di esercizio.



caprari
pumping power



caprari non stop **K⁺**

HIGH EFFICIENCY - ENERGY SAVING

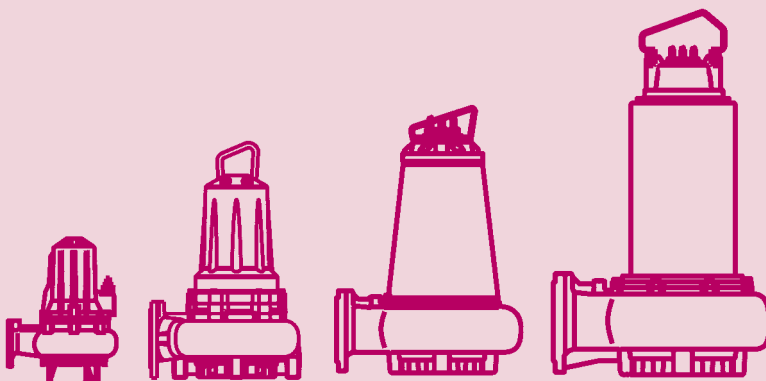

W
Open retracted
Vortex
Aperta arretrata



M
Single-channel
Monocanal
Monocanale



D
Double channel
A 2 canaux
Bicanale

K+ 50 Hz

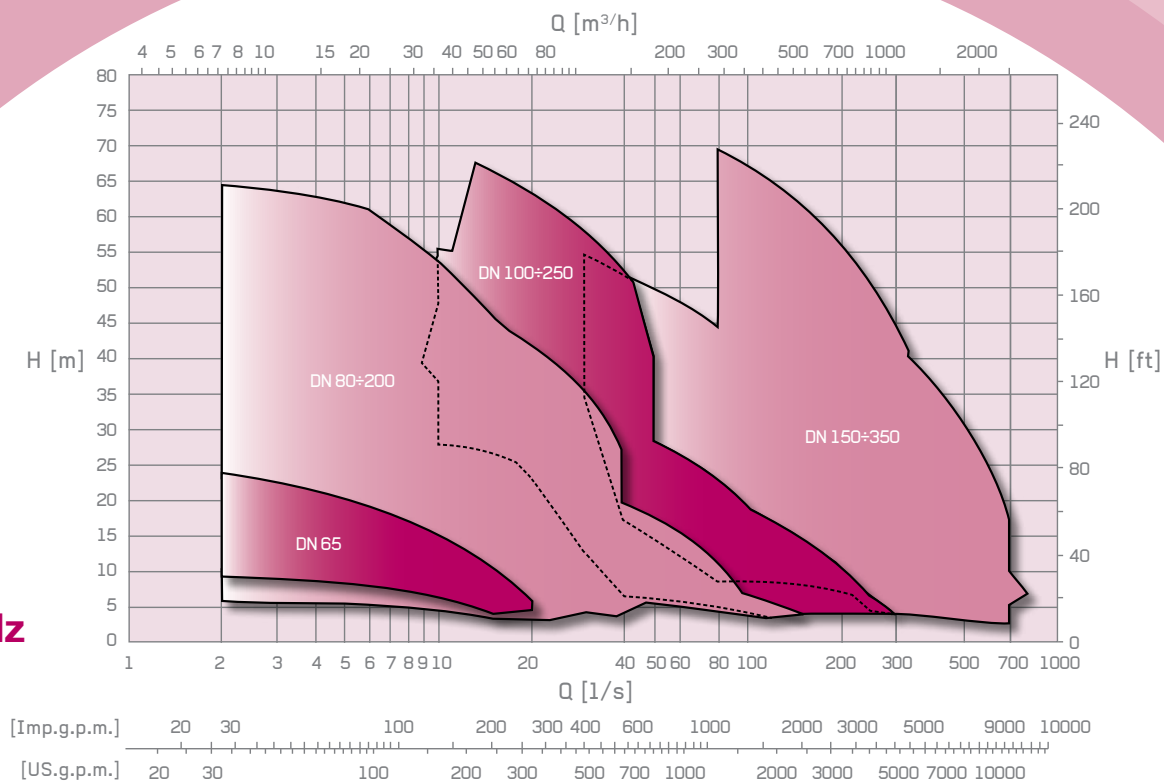

K+ 60 Hz

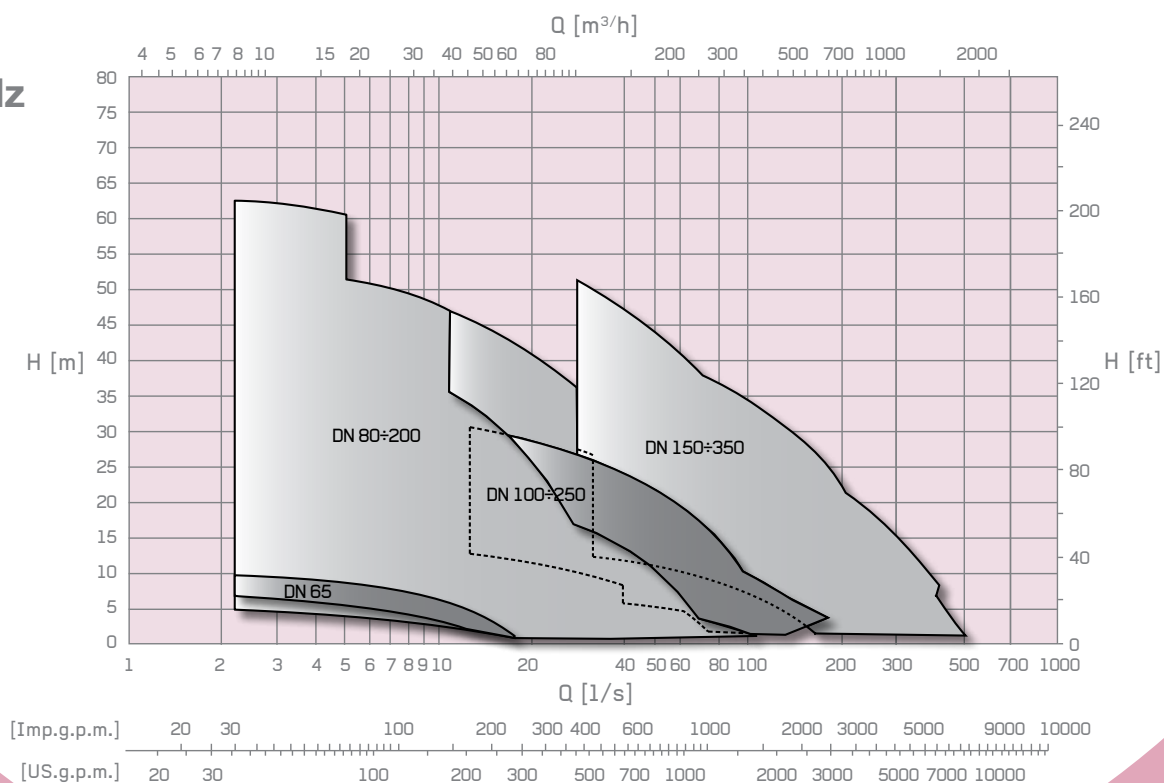

C Prevents fibrous material from building up near the seals by exercising a shredding action

Évite le dépôt de matières fibreuses à proximité des garnitures en agissant comme tranchant

Evita il deposito di materiali fibrosi in prossimità delle tenute agendo da tagliente

C “Pumping” effect: reduces the presence of fibrous matter around the mechanical seal when the wastewater is foul and contains long fibers.

Effet “pumping”: réduit la présence de matières fibreuses et de dépôts autour des garnitures mécaniques avec les liquides fortement chargés et les fibres longues

Effetto “pumping”: riduce la presenza di sostanze fibrose e depositi intorno alla tenuta meccanica con liquidi fortemente carichi e fibre lunghe

C Counter-blading system to relieve axial thrust and protect the bearing. Axial thrust is balanced by counter-blades, which create a pressure relieving action.

Pales de décharge pour protéger le palier; la poussée axiale est équilibrée par les pales à l’arrière de la roue qui décharge la pression

Sistema di contrapalette per scaricare la spinta assiale a protezione del cuscinetto; la spinta assiale è bilanciata dalle contrapalette che creano scarico di pressione

C Seal on discharge side:

- reduces vibrations
- guarantees sealing and prevents wear
- maintains the hydraulic characteristics of the pump over time
- prevents loss of head

Joint sur le refoulement:

- pour réduire les vibrations
- pour garantir l’étanchéité et éviter l’usure
- augmenter la longévité des caractéristiques hydrauliques de la pompe
- éviter les pertes de charge

Guarnizione sulla mandata:

- per ridurre le vibrazioni
- per garantire la tenuta ed evitare usura
- mantenere nel tempo le caratteristiche idrauliche della pompa
- evitare perdite di carico

C Hydrodynamic lift; prevents friction and keeps the impeller in the right position

Sustentation hydrodynamique; évite les frottements et maintient la roue guidée

Anello sede: sostentazione idrodinamica; evita attriti e mantiene la girante guidata

C Blading: cuts out the vortex effect, limiting the quantity of solids that build up in the wear plate areas

Ergots: Interrompent l’effet tourbillon, en limitant l’accumulation de matières solides au niveau des bagues d’usure

Palettatura: interrompe l’effetto vortice, limitando l’accumulo di sostanze solide nelle zone di rasamento



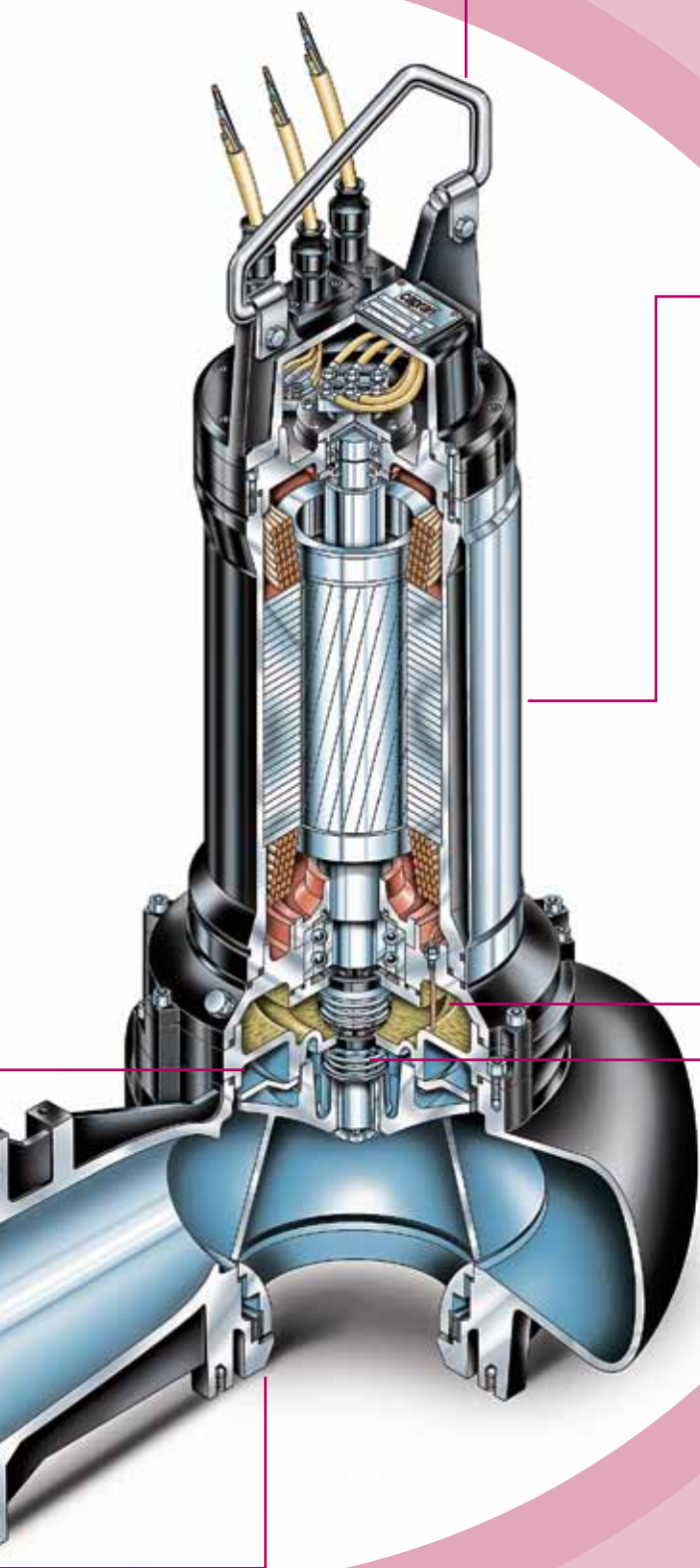

C Stainless steel handle for lifting purposes
Poignée de transport en acier inoxydable pour faciliter la manutention
Maniglia di sollevamento in acciaio inossidabile per una facile movimentazione

C Caprari installs “cold” motors in the K+ “non stop” series since the temperatures they reach are lower: protection of the winding and mechanical components
Sur les pompes K+ “non stop” Caprari monte un moteur “froid” dont la température atteint des valeurs réduites: protection de l’enroulement et des parties mécaniques
Caprari monta sulle K+ “non stop” un motore “freddo” che raggiunge valori di temperatura contenuti: protezione dell’avvolgimento e delle parti meccaniche

C Motor:

- protected from overtemperatures
- inverter resistant

Moteur:

- protégé contre les températures excessives
- pour variation de fréquence

Motore:

- protetto dalle sovratemperatures
- inverter resistant

C Conductivity probe to protect against water infiltration into the oil chamber
Sonde de conductivité pour protéger de l’infiltration d’eau dans la chambre à huile
Sonda di conduttività per la protezione dalle infiltrazioni d’acqua nella camera olio

C Seals:

- two separate mechanical seals
- standardized mechanical seals from the market (non-proprietary design)
- easy, economical maintenance
- the seal on the pump side can be replaced without having to remove the oil reservoir and leaving the motor protected by the other seal

Dispositifs d’étanchéité:

- deux garnitures mécaniques séparées
- garnitures mécaniques normalisées disponible dans le commerce (dessin libre de droit)
- économie grâce à la facilité d’entretien
- l’étanchéité de la pompe peut être changée sans déposer le carter d’huile et en laissant le moteur protégé par l’autre étanchéité

Dispositivo di tenuta:

- due tenute meccaniche separate
- tenute meccaniche normalizzate da commercio (disegno non proprietario)
- manutenzione facile ed economica
- la tenuta lato pompa può essere sostituita senza rimuovere la scatola olio e lasciando il motore protetto dall’altra tenuta

K+ DN 65 (kW 1,25 ÷ 2,2)

K..W065F
K..M065F

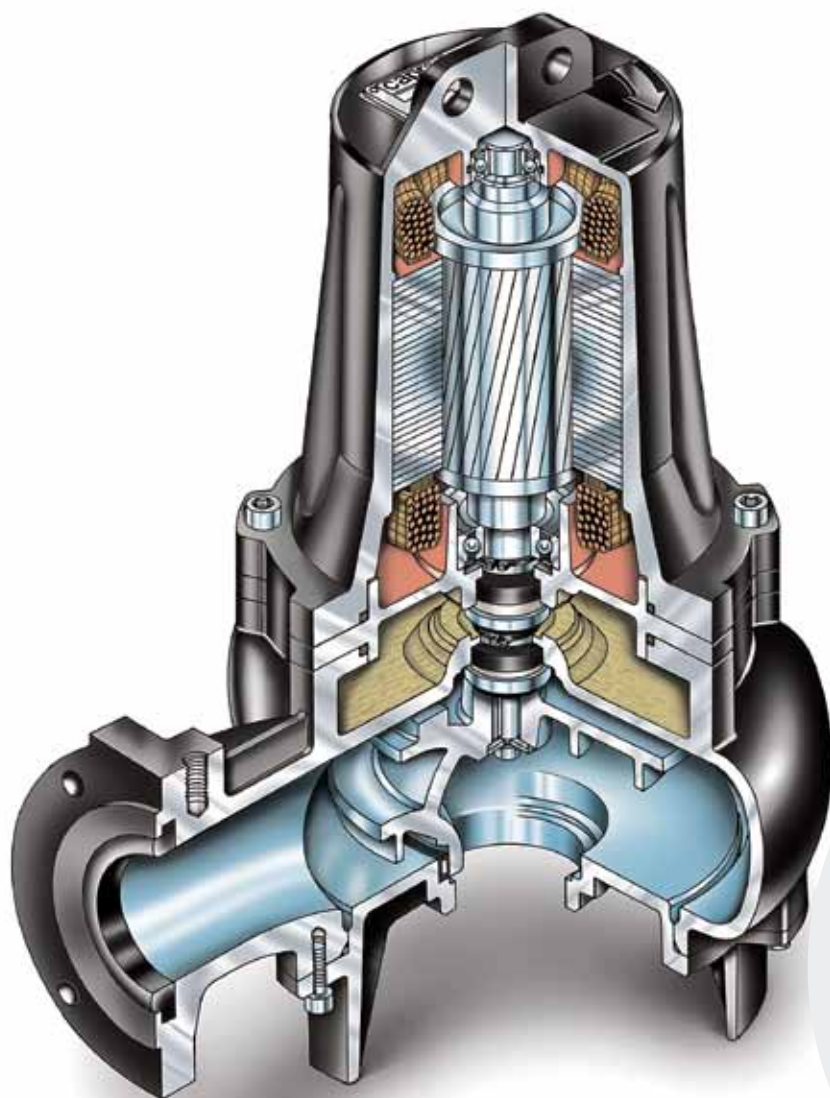

This model has the same basic technical solutions as the higher range in a simplified casing, giving it the same reliability, working life and quality performance but in a power range more commonly found in models designed for domestic and similar uses.

Le maintien des solutions techniques de base de la gamme supérieure dans une structure mécanique simplifiée confère à ce modèle la même fiabilité, longévité et qualité des performances, dans une catégorie de puissance typique des machines à usage domestique ou similaire.

Il mantenimento, in una struttura meccanica semplificata, delle soluzioni tecniche di base della gamma superiore conferisce a questo modello la medesima affidabilità, durata e qualità di prestazioni in una fascia di potenza tipica di macchine di uso domestico o similare.

INSTALLATION / INSTALLATIONS / INSTALLAZIONI

Submersed fixed
Immergée fixe
Immersa fissa

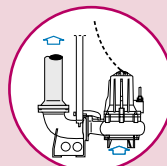

Submersed mobile
Immergée transportable
Immersa trasportabile

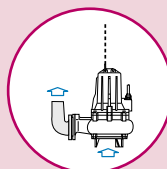

All models are available in ATEX II 2G Exd IIB T4 explosion-proof versions.
Tous les modèles sont disponibles en version antidéflagrante ATEX II 2G Exd IIB T4.
Tutti i modelli sono disponibili in versione antidéflagrante ATEX II 2G Exd IIB T4.

Special constructions UPON REQUEST
Construction spéciales SUR DEMANDE
Esecuzioni speciali SU RICHIESTA

K+ DN 80 ÷ 200 (kW 1,1 ÷ 15)

K..W080H
K..M080H
K..W080L
K..M080L
K..M100H
K..W100L
K..M150L

K..D200N
(+ 006562..)

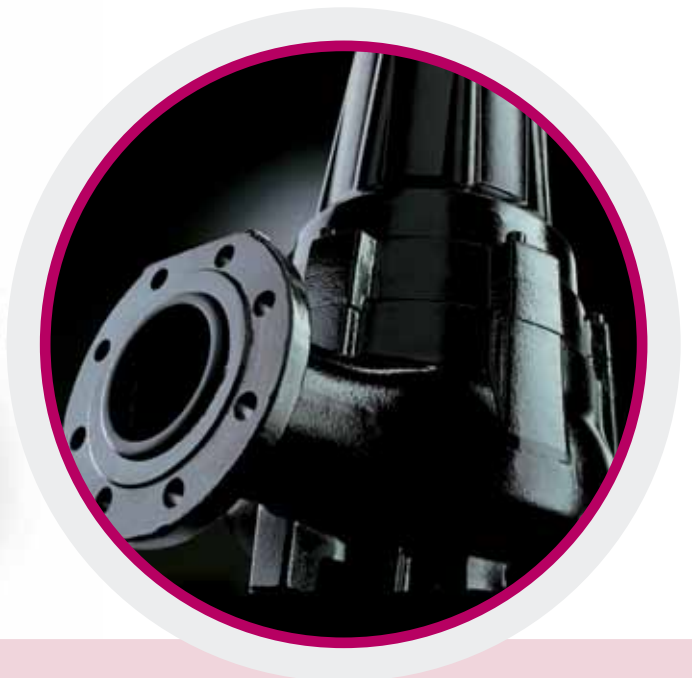
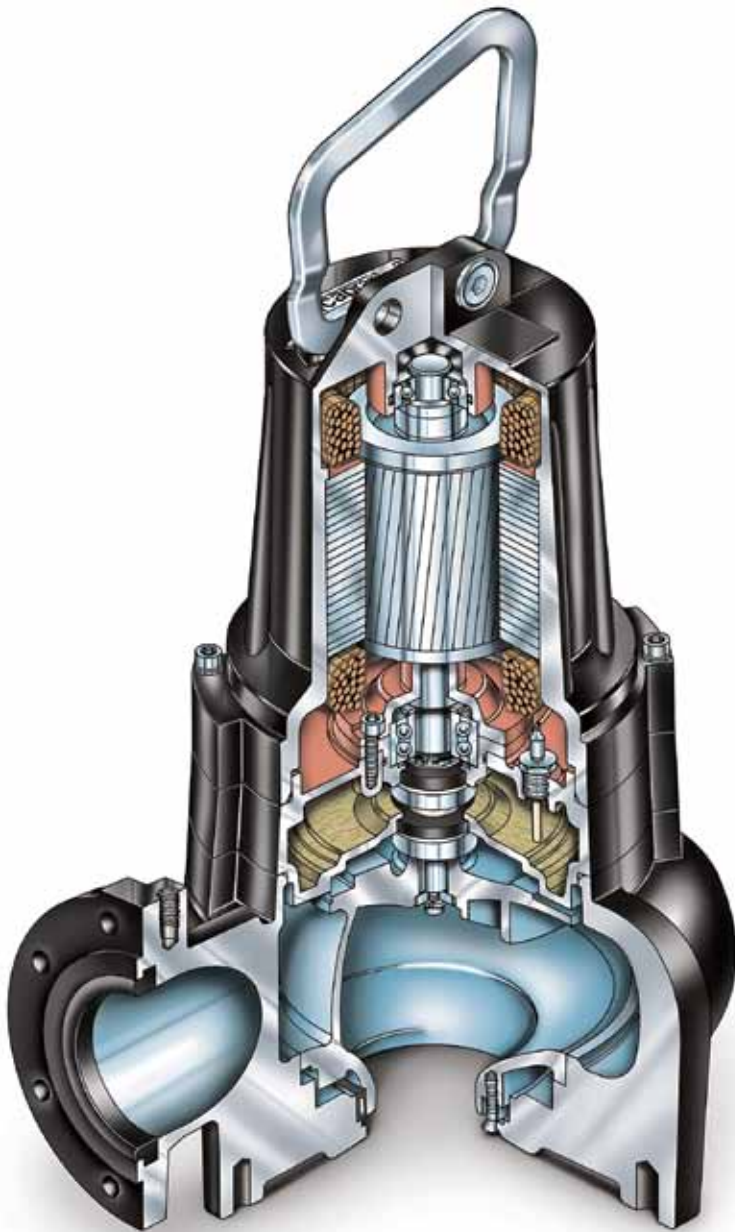

The compact construction, carefully designed hydraulics, perfect mechanical proportions, generously scaled electrical fittings and standard supply safety devices give the range a high level of reliability and long life, putting the product at the top end of the market in terms of quality.

Une construction compacte, une hydraulique perfectionnée, un dimensionnement mécanique optimisé, un équipement électrique riche et des dispositifs de sécurité standard confèrent à cette gamme une fiabilité accrue et une longue durée de vie, en plaçant le produit dans le haut de gamme du marché par sa qualité.

La costruzione compatta, l'accurato progetto idraulico, l'ottimizzato dimensionamento meccanico, il generoso equipaggiamento elettrico e la dotazione di serie di dispositivi di sicurezza conferiscono alla gamma un'elevata affidabilità ed una lunga durata collocando il prodotto nella fascia di mercato superiore per qualità.

INSTALLATION / INSTALLATIONS / INSTALLAZIONI

Submersed fixed
Immergée fixe
Immersa fissa

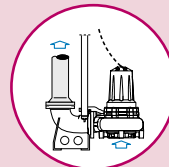

Submersed mobile
Immergée transportable
Immersa trasportabile

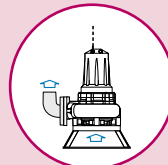

All models are available in ATEX II 2G Exd IIB T4 explosion-proof versions.
Tous les modèles sont disponibles en version antidéflagrante ATEX II 2G Exd IIB T4.
Tutti i modelli sono disponibili in versione antidéflagrante ATEX II 2G Exd IIB T4.

Special constructions UPON REQUEST
Construction spéciales SUR DEMANDE
Esecuzioni speciali SU RICHIESTA

K+ DN 100 ÷ 250 (kW 9 ÷ 32)

K..W100N
K..M100N
K..M150N
K..M200P
K..D200N
K..D250P

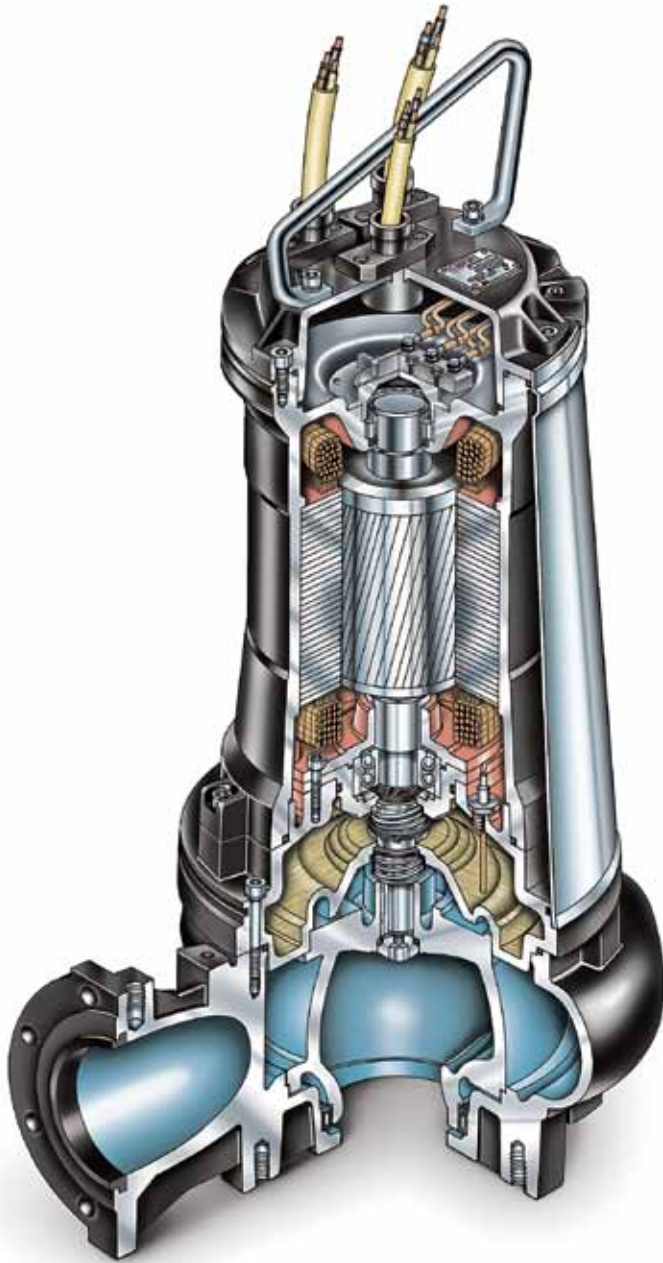

It combines the newly upgraded winning technical concepts of the lower range with a number of technical innovations specially devised for continuous heavy-duty use, which, in addition to the standard requirements, also calls for maximum versatility, ease of maintenance and reliability in use.

C'est l'évolution normale des conceptions techniques gagnantes de la gamme inférieure. Elle intègre des solutions innovatrices dans une classe d'utilisation particulièrement lourde et continue qui requiert, en plus de ses qualités éprouvées, le maximum de polyvalence, de facilité de maintenance et de fiabilité d'utilisation.

Rappresenta la normale evoluzione dei concetti tecnici vincenti della gamma inferiore con l'aggiunta di soluzioni innovative in una fascia di utilizzo in cui l'impiego gravoso e continuativo richiede, oltre alle qualità già note, massima versatilità, manutenibilità e affidabilità d'impiego.

INSTALLATION / INSTALLATIONS / INSTALLAZIONI

Submersed fixed
Immergée fixe
Immersa fissa

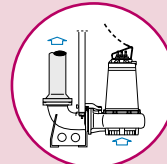

Horizontal in a dry chamber (R)
Fosse sèche horizontale (R)
Camera asciutta orizzontale (R)

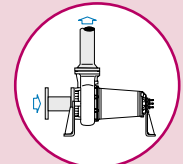

Submersed mobile
Immergée transportable
Immersa trasportabile

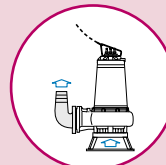

Vertical in a dry chamber (R)
Fosse sèche verticale (R)
Camera asciutta verticale (R)

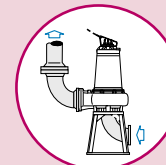

All models are available in ATEX II 2G Exd IIB T4 explosion-proof versions.
Tous les modèles sont disponibles en version antidéflagrante ATEX II 2G Exd IIB T4.
Tutti i modelli sono disponibili in versione antidéflagrante ATEX II 2G Exd IIB T4.

Special constructions UPON REQUEST
Construction spéciales SUR DEMANDE
Esecuzioni speciali SU RICHIESTA

K+ DN 150 ÷ 350 (kW 17 ÷ 180)

K..M150R
K..M250Z
K..M250R
K..D300Z
K..D300R
K..D350R
K..M250T
K..D300T
K..D350T

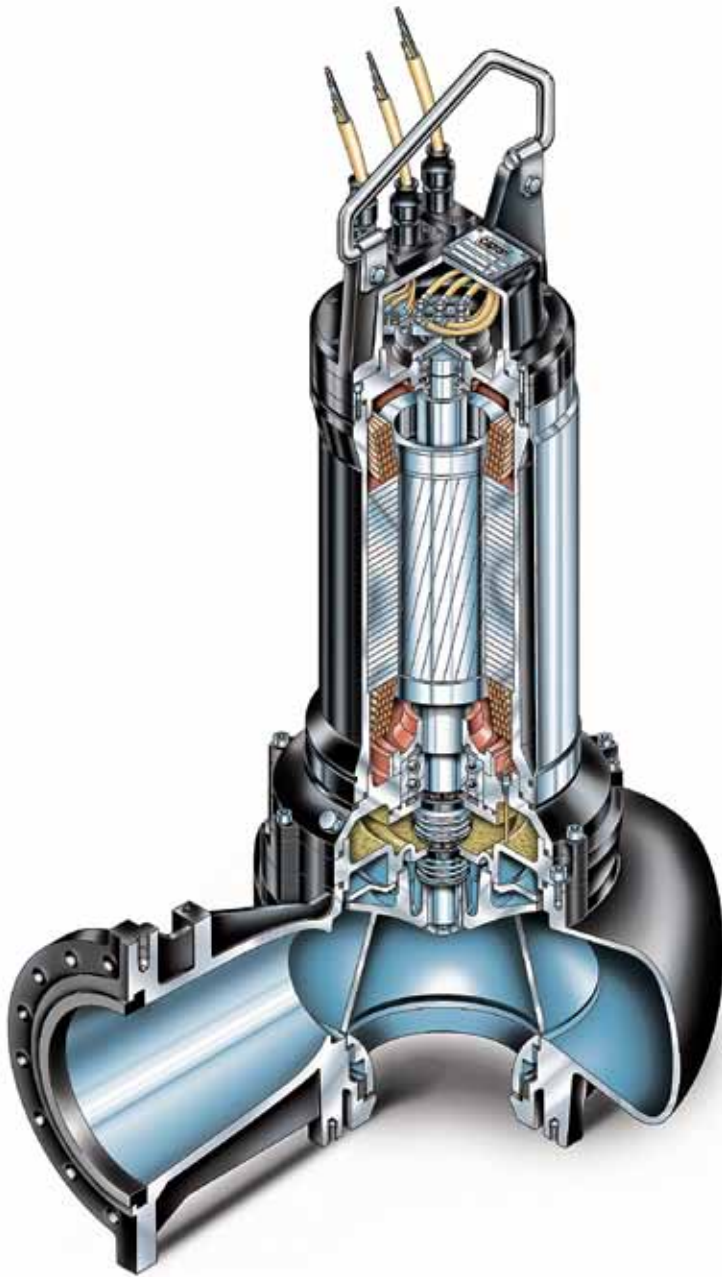

These pumps, the fruit of an innovative design philosophy, as well as having all the specific features of the pumps in the lower range, are characterised by their self-cleaning hydraulics and double-channel impellers, guaranteeing greater reliability and increased hydraulic efficiency even at high pressures. Management of the range is simplified by the use of a single oil casing for the whole range and the interchangeability of models with the same diameter DN.

Fruit d'une philosophie de conception novatrice, ces pompes, outre intégrer toutes les spécificités des matériels de la classe inférieure, se distinguent par une hydraulique autonettoyante et des roues à 2 canaux qui garantissent non seulement une plus grande fiabilité, mais aussi un rendement plus élevé aux hautes pressions. En outre, la simplicité de gestion passe par l'adoption d'un seul carter d'huile pour toutes les séries et l'interchangeabilité des modèles ayant le même diamètre DN.

Frutto di una innovativa filosofia di progettazione, queste pompe, oltre a racchiudere tutte le peculiarità delle pompe appartenenti alla gamma inferiore, sono caratterizzate da idrauliche autopulenti e da giranti bicanali che garantiscono una maggior affidabilità, nonché un elevato rendimento idraulico anche alle alte pressioni. L'adozione di un'unica scatola d'olio per tutte le serie e l'intercambiabilità dei modelli a parità di diametro DN, consentono una maggiore semplicità di gestione.

INSTALLATION / INSTALLATIONS / INSTALLAZIONI

Submersed fixed
Immersée fixe
Immersa fissa

Horizontal in a dry chamber (R)
Fosse sèche horizontale (R)
Camera asciutta orizzontale (R)

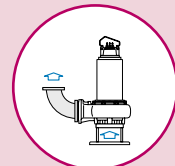
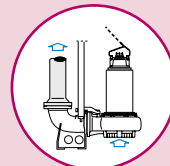

Submersed mobile
Immersée transportable
Immersa trasportabile

Vertical in a dry chamber (R)
Fosse sèche verticale (R)
Camera asciutta verticale (R)

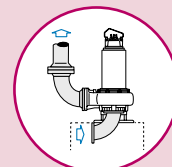
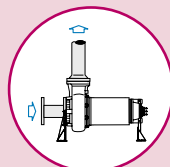

All models are available in ATEX II 2G Exd IIB T4 explosion-proof versions.
Tous les modèles sont disponibles en version antidéflagrante ATEX II 2G Exd IIB T4.
Tutti i modelli sono disponibili in versione antidéflagrante ATEX II 2G Exd IIB T4.

Special constructions UPON REQUEST
Construction spéciales SUR DEMANDE
Esecuzioni speciali SU RICHIESTA

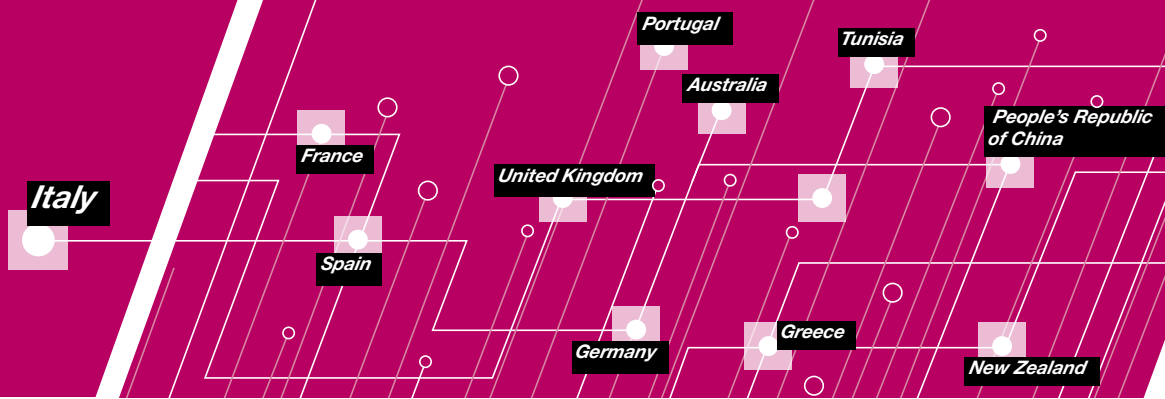

Water Collection and Distribution



Boosting and Distribution of surface water



Wastewater Transport and Treatment



Pump Control Technology

caprari

pumping power



motralec

4 rue Lavoisier . ZA Lavoisier . 95223 HERBLAY CEDEX
 Tel. : 01.39.97.65.10 / Fax. : 01.39.97.68.48
 Demande de prix / e-mail : service-commercial@motralec.com
www.motralec.com