

Goulds 3185

Heavy-duty Process Pumps

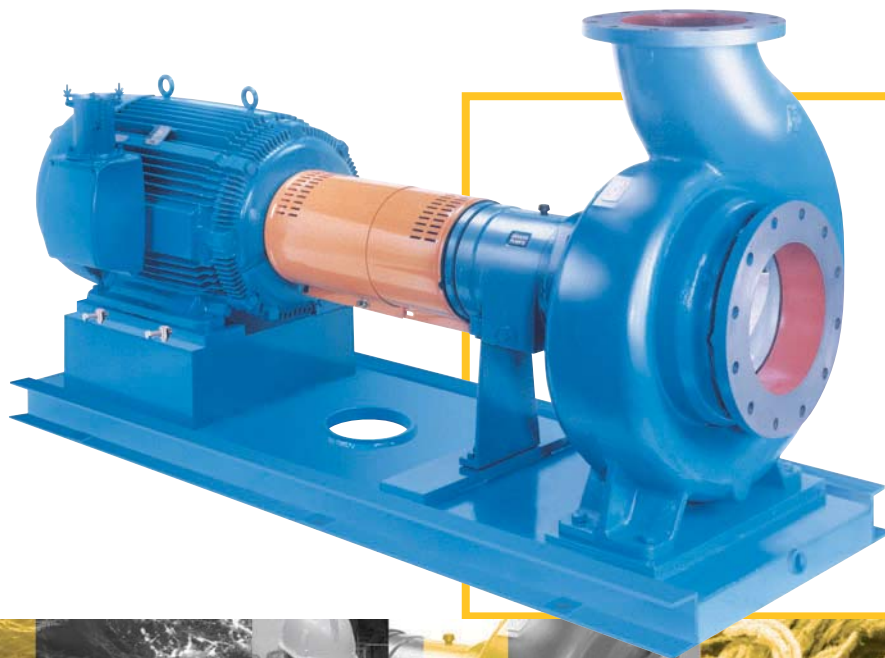

ITT

motralec

4 rue Lavoisier . ZA Lavoisier . 95223 HERBLAY CEDEX
Tel. : 01.39.97.65.10 / Fax. : 01.39.97.68.48
Demande de prix / e-mail : service-commercial@motralec.com
www.motralec.com

Goulds 3185

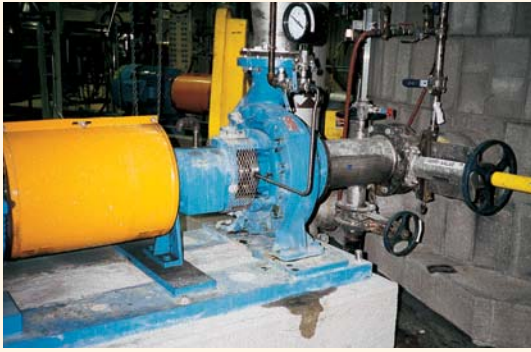

Above: A Model 3185 installed in a recycle mill.

Below: Model 3185 on difficult high temperature service. Spring-mounted baseplate provided to compensate for thermal expansion.



Below: Cooling water pump for primary turbine at a power plant in the Middle East.



- ◆ Capacities to 6000 m³/h (26,000 GPM)
- ◆ Heads to 125 m (410 feet)
- ◆ Temperatures to 230° C (446°F)
- ◆ Pressures to 16 bar (232 PSIG)

World-wide Experience on Process Pumping Services

When Goulds developed the 3185, we utilized 140 years of pump design experience to ensure it would have unmatched mechanical reliability. Today, installations around the world attest to its remarkable performance.

The 3185 is the heavy duty process pump designed to handle all of your tough process pumping applications.

World-class Pump Line

Model 3185 is built to Metric standards.

- ◆ ISO or JIS 16 bar flange drilling
- ◆ mm-dimensioned O.D. of mechanical seal sleeve
- ◆ mm-dimensioned bearing locknut
- ◆ mm-dimensioned shaft and keyway at coupling
- ◆ International design 3185 pumps comply to ISO 5199 with eight sizes conforming to ISO 2858 dimensions. Metric fasteners and fittings used throughout.

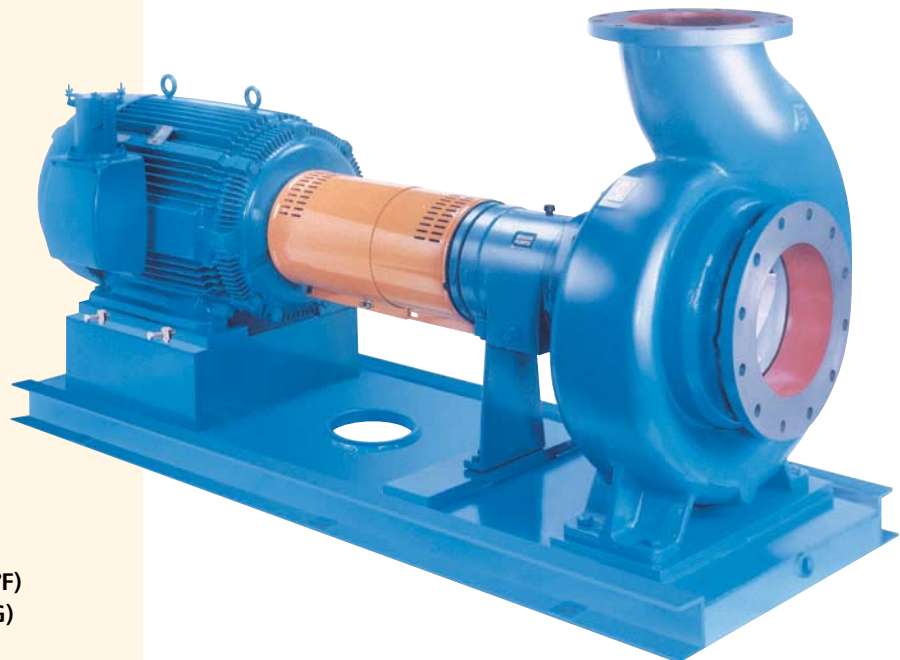



Model 3185

LUBRICATION FLEXIBILITY

The preferred lubrication of oil is standard. No special parts required to convert to grease.

STANDARD LABYRINTH OIL SEALS

Prevent premature bearing failure caused by lubricant contamination and loss of lubricant.

CONTINUOUS HIGH-PERFORMANCE

Original high efficiency maintained by simple external impeller adjustment resulting in long term energy savings.

HEAVY-DUTY SHAFT

Designed for minimum deflection at maximum load. Dry shaft achieved by sealing from pumpage by O-rings at sleeve and impeller nut.

RIGID FEET

Large casing and bearing frame feet maintain driver alignment with high pipe loads; absorb system vibration.

SEALING FLEXIBILITY

Choice of mechanical seal (illustrated), packed box or dynamic seal.

TAPERBORE™ PLUS SEAL CHAMBER

Wide range of sealing arrangements available to meet service conditions. Patented seal chambers improve lubrication and heat removal (cooling) of seal faces for extended seal life and pump uptime.

CASING

Top centerline discharge for air handling and self-venting. Special volute design reduces radial loads. Back pull-out design. Foot-mounted.

RENEWABLE SUCTION SIDEPLATE

With open impeller design minimizes maintenance costs. Positively sealed with O-ring and gasket.

OPEN IMPELLER

Full back shroud and thick impeller vanes for handling slurries and stringy fibers. Large balance holes and back pump-out vanes minimize stuffing box pressure and axial thrust. Optional enclosed impeller available. Shearpeller™ design available for difficult recycle services.

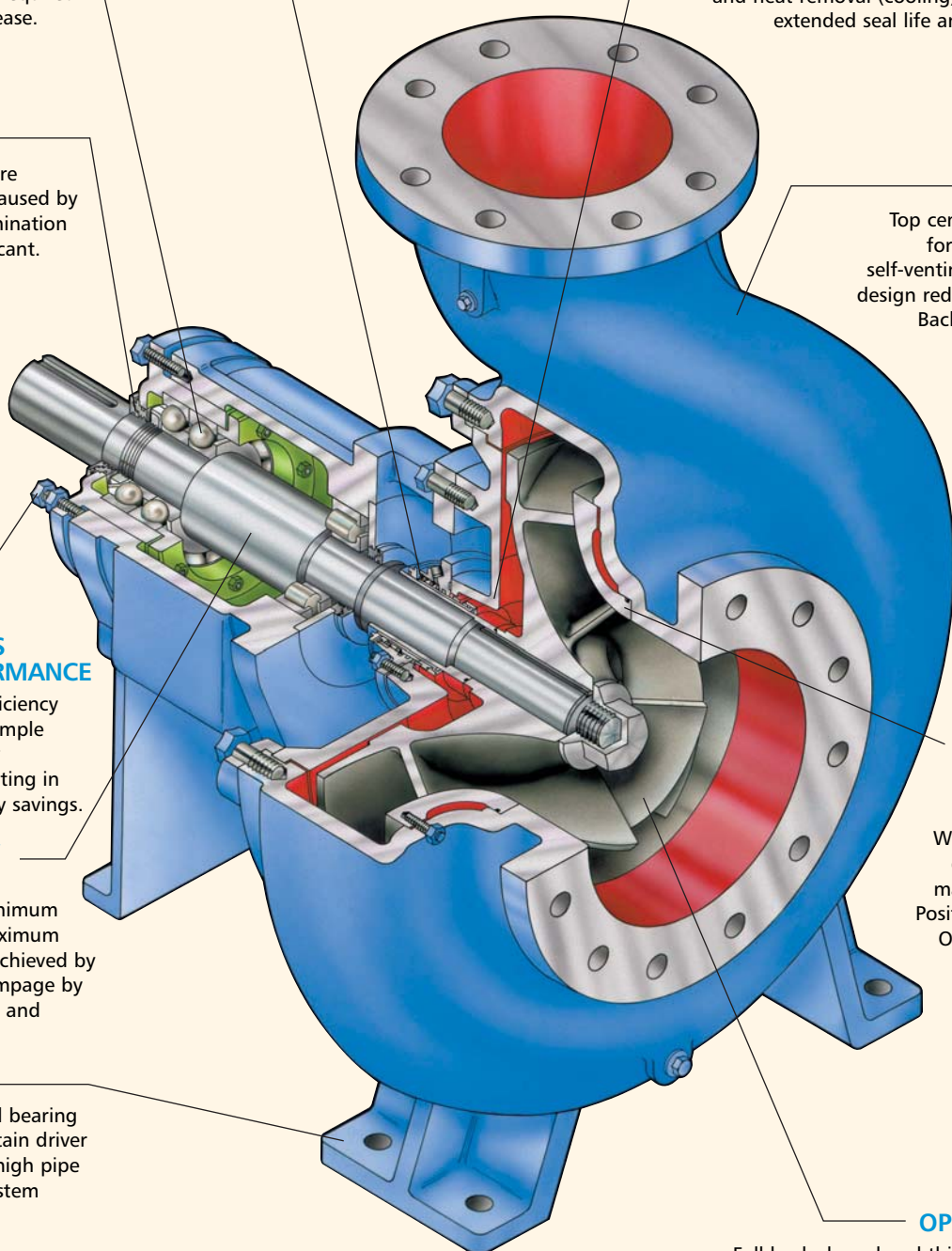

See The Difference

Engineered Impeller and Sideplate

Acknowledged best design for industrial process services

It offers:

1. Ease of adjustment to maintain optimum performance
2. Clamped sideplate for maximum reliability and zero leakage
3. Minimum hydraulic loads for maximum mechanical reliability

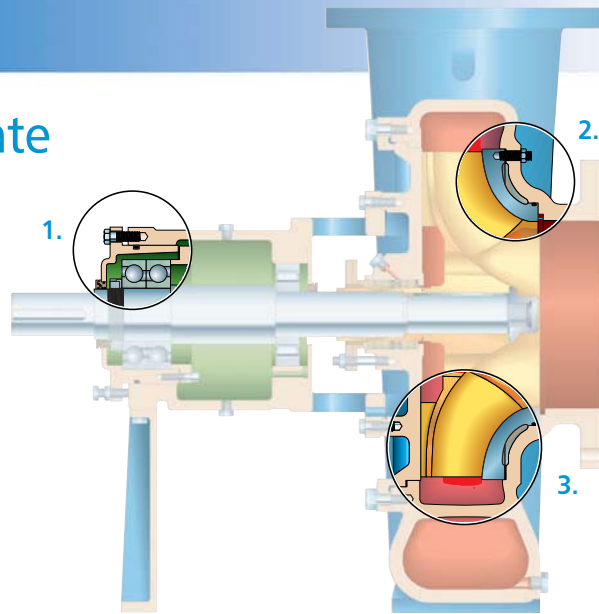

1 Renewable High-performance

Easy and reliable

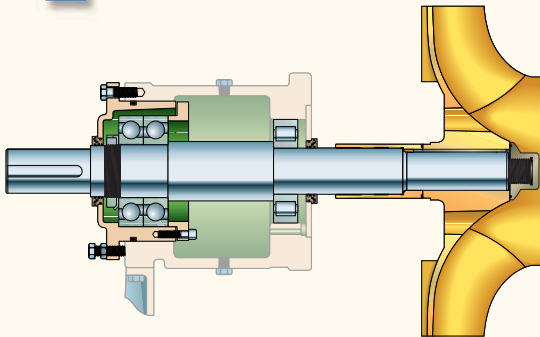

With any impeller adjustment there will be two metal components that will have to move relative to each other. Goulds puts this precision fit in the sealed and lubricated environment of the power end.

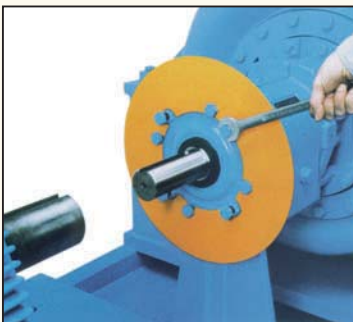

Easy and accessible adjustments. The Goulds adjustment bolts are very accessible and can be adjusted with one tool.

VS.

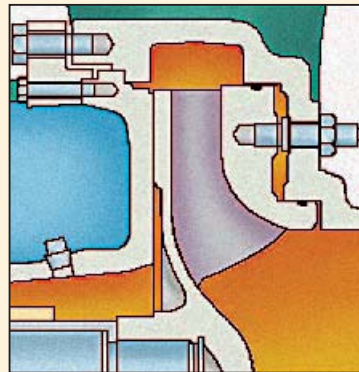

Less reliable pumps utilizing adjustable sideplates are difficult to adjust, are not precise in clearances and the adjustment must take place in the corroded casing interior leading to leakage. Improper adjustments lead to broken studs and catastrophic failure.



VS.

The adjustable sideplate method requires two tools. Additionally, the pump suction flange limits the accessibility to the adjusting screws.

2 Clamped Sideplate

For maximum reliability and zero leakage

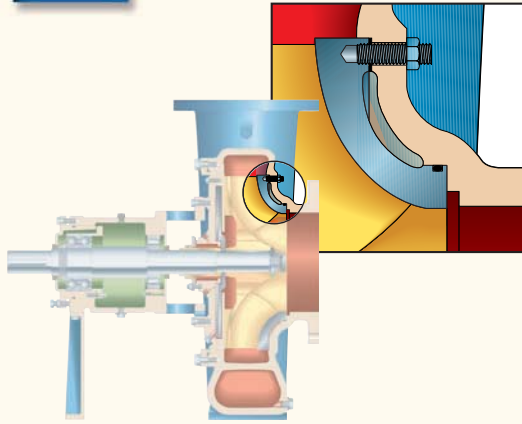

CLAMPED

Our sideplate is clamped securely and sealed positively to ensure that it does not lead to breakage or leakage.

VS.

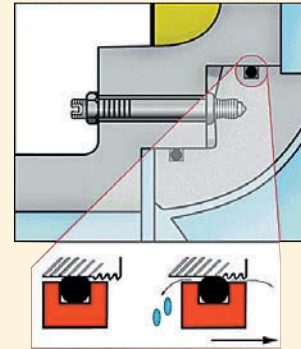

FLOATING

The "floating" sideplate design must scrape over a casing surface that will be corroded and fouled. This commonly leads to a leakage path through the sideplate studs.

3 Minimum Hydraulic Loads

Maximum mechanical reliability

Goulds open impeller design was engineered to assure minimum radial and axial thrust loads to maximize seal and bearing life.

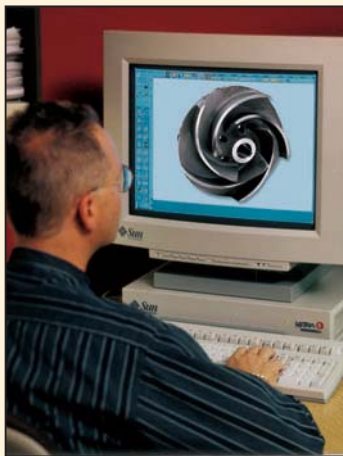

1. Full back shroud — maximizes mechanical integrity
2. Balance holes — low axial thrust
3. Engineered back vanes — extended seal and bearing life

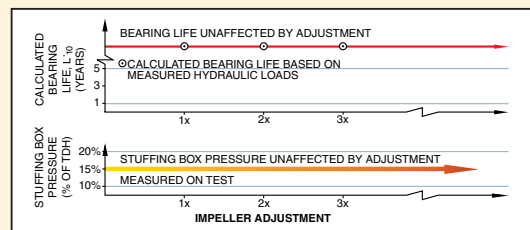
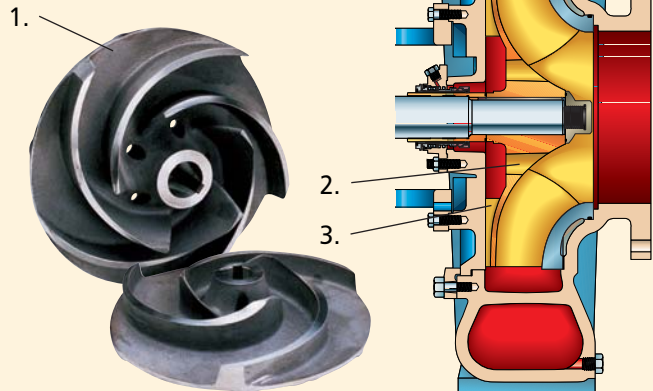

ENGINEERED FOR LONG LIFE

Back vane height/angle and shroud design are engineered to minimize hydraulic loads throughout the life of the pump. Bearing life is guaranteed.

As the open impeller is adjusted and performance renewed, back pump-out vanes control axial thrust. Bearing and seal life are maintained — unaffected by adjustment.

Power Ends Designed for Maximum Reliability

Power End Reliability is vital when thinking about pump *mean time between failure* (MTBF). To ensure maximum bearing life, the 3185 follows three key bearing design factors:

1. Bearing Design Life
2. Bearing Temperature
3. Bearing Environment

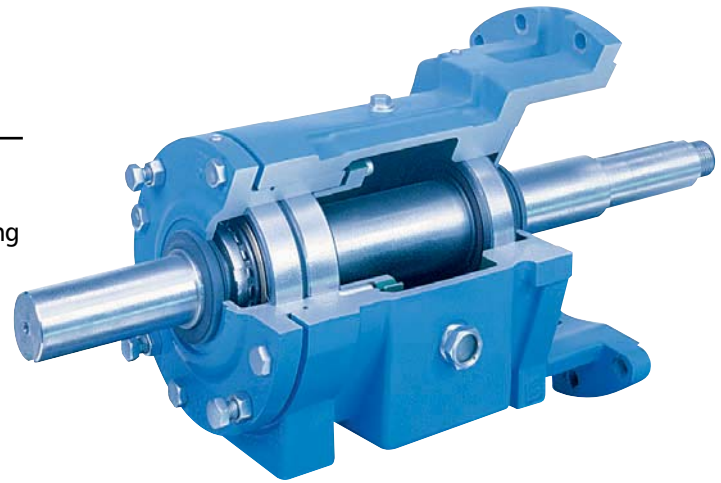

1 Bearing design life

Bearing manufacturers state that skidding, cage stresses and oil temperatures can greatly reduce the bearing life of oversized bearings. The "right" size bearing is vital to overall bearing life.

Bearing Load Measured on Test



Bigger is NOT always better!

Bearings are often oversized because pump designers often estimate bearing loads. Goulds measured their loads on test and chose bearing designs that would enable bearing life of 100,000 hours.

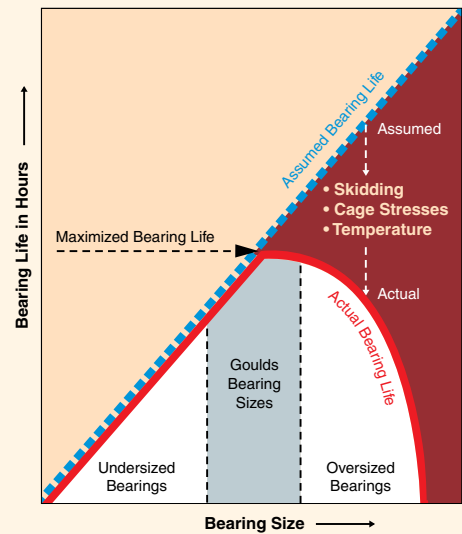

2 Bearing temperature

Keeping the pump loads minimized and selecting the "right" bearing will keep bearing temperature under control.

Bearing Temperature vs. Size

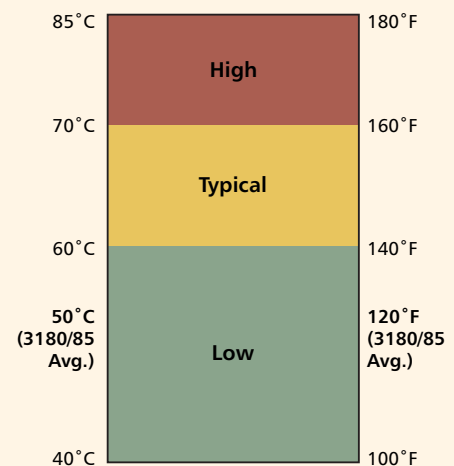
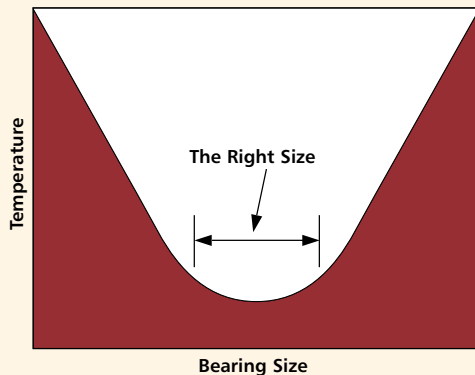

Typical bearing operating temperatures of competitor's process pumps are between 60-70°C. Goulds Model 3185 bearing temperatures average only 50°C/120°F!

3 Bearing environment Labyrinth oil seals are standard

Contamination being the second leading cause of bearing failure requires special attention. Common lip seals were not considered due to their 2,000 hour design life. After wearing out, there will be an open passage way for contamination. For this reason, our 3185 is supplied with Inpro VBXXD labyrinth oil seals as standard. The Inpro VBXXD is the industry's leading bearing isolator and provides the best operating environment for the bearing.

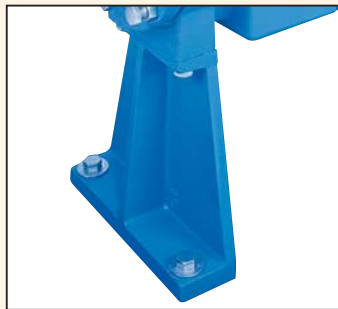
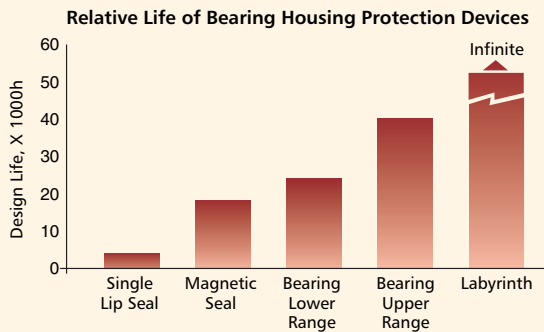

RIGID FRAME FOOT
Heavy duty foot reduces effects of pipeloads/thermal expansion on bearing life. Bearings continue to run cool.

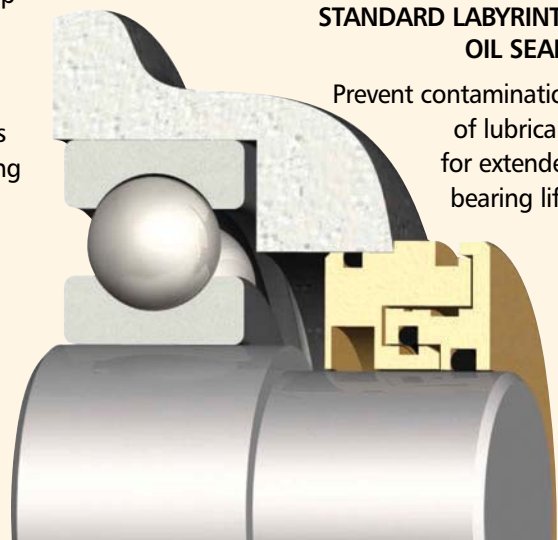

STANDARD LABYRINTH OIL SEALS

Prevent contamination of lubricant for extended bearing life.



LARGE OIL SIGHT GLASS

The standard oil sight glass assures oil level is properly set and maintained. Condition of oil is also easily monitored.

Power end reliability is both designed-in and guaranteed

- Bearing Design Life..... ✓ (>100,000 hours)
- Bearing Temperature..... ✓ (50°C/120°F average)
- Bearing Environment..... ✓ (Superior Oil Seal design)
- Guarantee..... ✓ (Reliability Guarantee)

Our guarantee

Goulds Pumps backs the 3185 power ends with an unconditional guarantee against defects in workmanship and material for 3 years from date of manufacture.

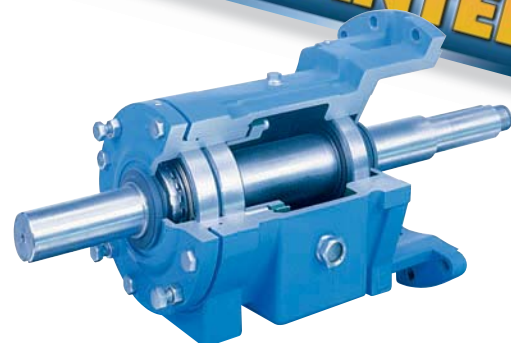

Impeller Designs to Optimize Performance

The right design for the service results in optimum efficiency and up-time, especially when handling difficult media such as recycle fibers with contaminants.

1

Open Impeller

Design suitable for most services. Allows for resistance to wear and corrosion. Provides for easily renewable clearances. Designed for optimum efficiency.



2

Enclosed Impeller

Available for services where efficiency is a consideration and enclosed design is suitable for service conditions. Efficiency can be renewed with axial adjustment and/or wear ring replacement. Also beneficial for high temperature services as it allows the suction sideplate to be eliminated.



Goulds clog-free pumping solution patented design (# 6,609,890)

Pumping applications in recycle mills present unique challenges with the presence of plastic and tape along with other contaminants that can readily clog the pump impeller.

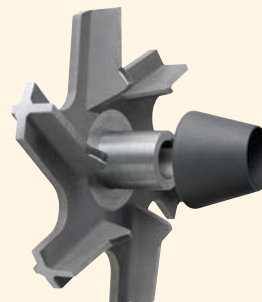

3

The Goulds Shearpeller™ solves this problem:

- ◆ Generous front clearance with vortex-type design to prevent binding and plugging.
- ◆ Patented tapered inlet sleeve prevents contaminants from plugging inlet area. The sleeve is loose to rotate independently from impeller. The slower rotation prevents contaminants from collecting at the impeller eye and prevents erosion of hub.
- ◆ Proven in tough services such as repulper dump service in OCC recycle mill. In one service, pump went from a daily outage to clear impeller to uninterrupted, continuous service.
- ◆ Component changes only involve the impeller and sleeve. Uses same casing, sideplate, shaft and impeller nut as 3185.

Optimize Seal Configuration for Service and Environment

1

For services with solids and vapor Goulds-patented **TaperBore™ PLUS**

How It Works: The unique flow path created by the patented Vane Particle Ejector directs solids away from the mechanical seal, not at the seal as with other tapered bore designs. And, the amount of solids entering the bore is minimized. Air and vapors are also efficiently removed.

1. Solids/liquid mixture flows toward mechanical seal/seal chamber.
2. Turbulent zone. Some solids continue to flow toward shaft. Other solids are forced back out by centrifugal force (generated by back pump-out vanes).
3. Clear liquid continues to move toward mechanical seal faces. Solids, air, vapors flow away from seal.
4. Low pressure zone created by Vane Particle Ejector. Solids, air, vapor liquid mixture exit seal chamber bore.
5. Flow in TaperBore™ PLUS seal chamber assures efficient heat removal (cooling) and lubrication. Seal face heat is dissipated. Seal faces are continuously flushed with clean liquid.

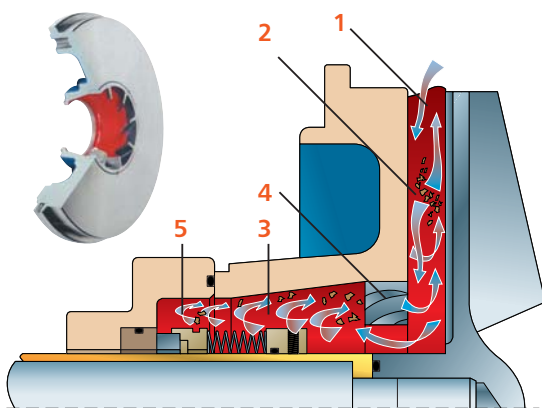

2 Zero flush water (Mechanical seals)

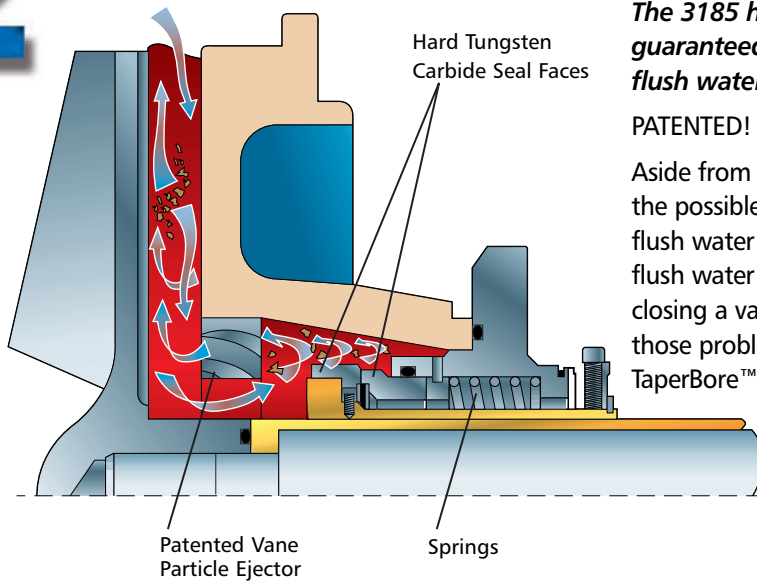

The 3185 has a revolutionary seal chamber design guaranteed to operate on 6% paper stock without flush water!

PATENTED! No. 5,336,048

Aside from the high cost of flushing mechanical seals and the possible dilution of the product, contaminants in the flush water can also cause seal failures. Disruption of flush water caused by plugging, freezing or inadvertently closing a valve can also cause failures. The answer to those problems is solved with the Goulds patented TaperBore™ PLUS.

3 Dynamic seal

For elimination of mechanical seal problems; reduced maintenance

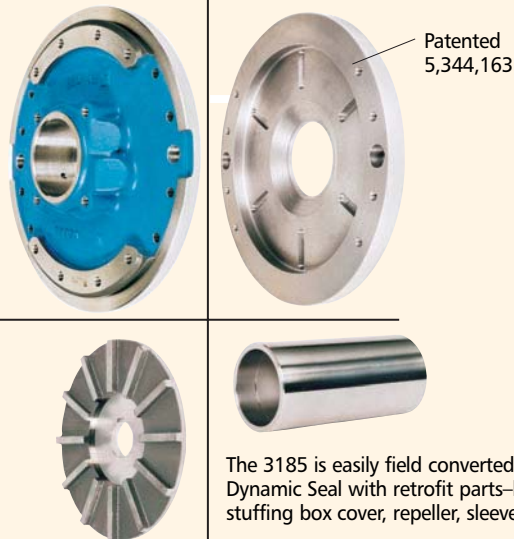

The 3185 is easily field converted to Dynamic Seal with retrofit parts—backplate, stuffing box cover, repeller, sleeve.

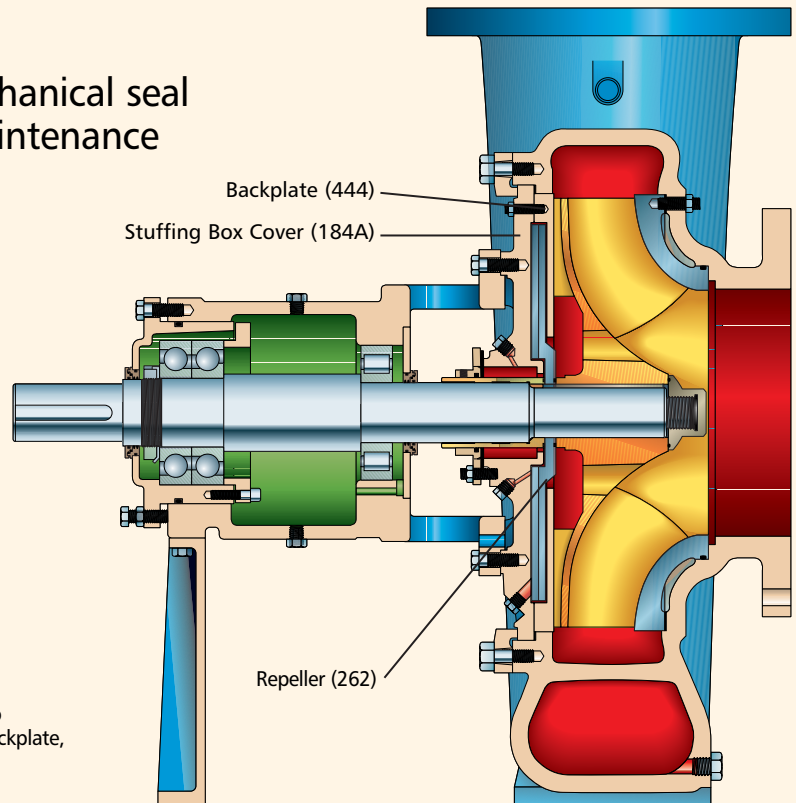

Goulds *Dynamic Seal* option is ideally suited to handle the tough applications where conventional mechanical seals or packing require outside flush and/or constant, costly attention. This option allows pumping slurries without an external flush. A repeller between the stuffing box cover and impeller pumps liquid from the stuffing box while the pump is running. A diaphragm seal prevents leakage when the pump is not operating.

Benefits of Goulds Dynamic Seal:

- ◆ External seal water not required.
- ◆ Elimination of pumpage contamination or product dilution.
- ◆ Eliminates problems and costs associated with piping from a remote source.

Hydraulic Coverage 50 Hz

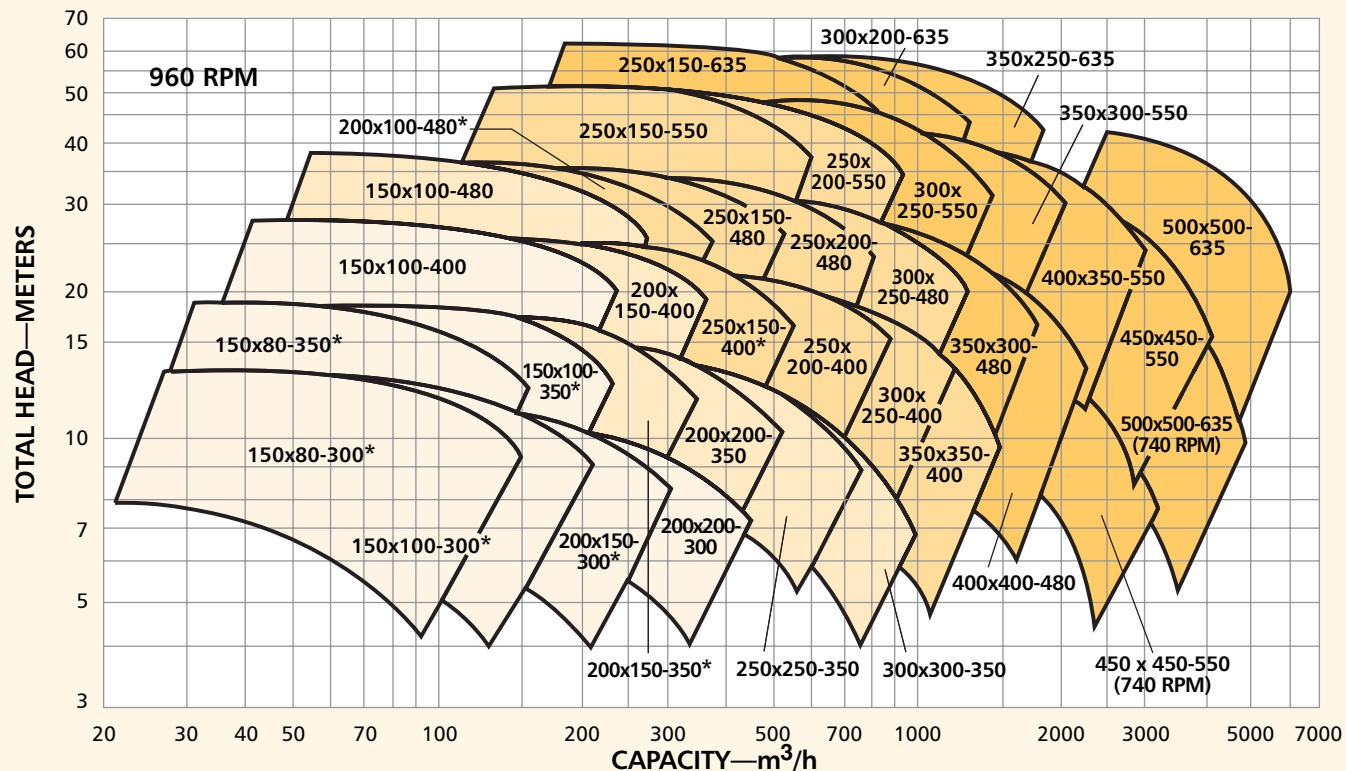
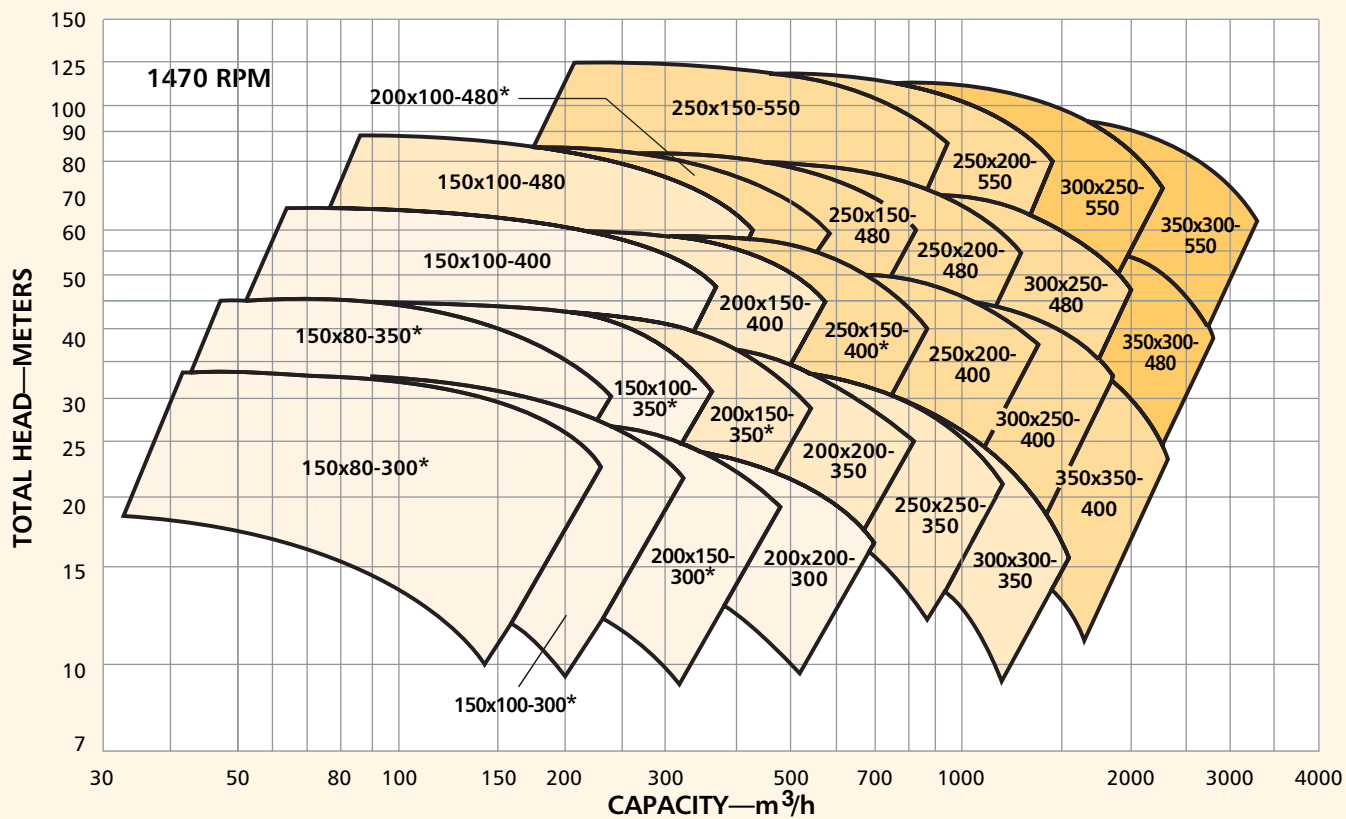

*Available with ShearPeller™

Hydraulic Coverage 60 Hz

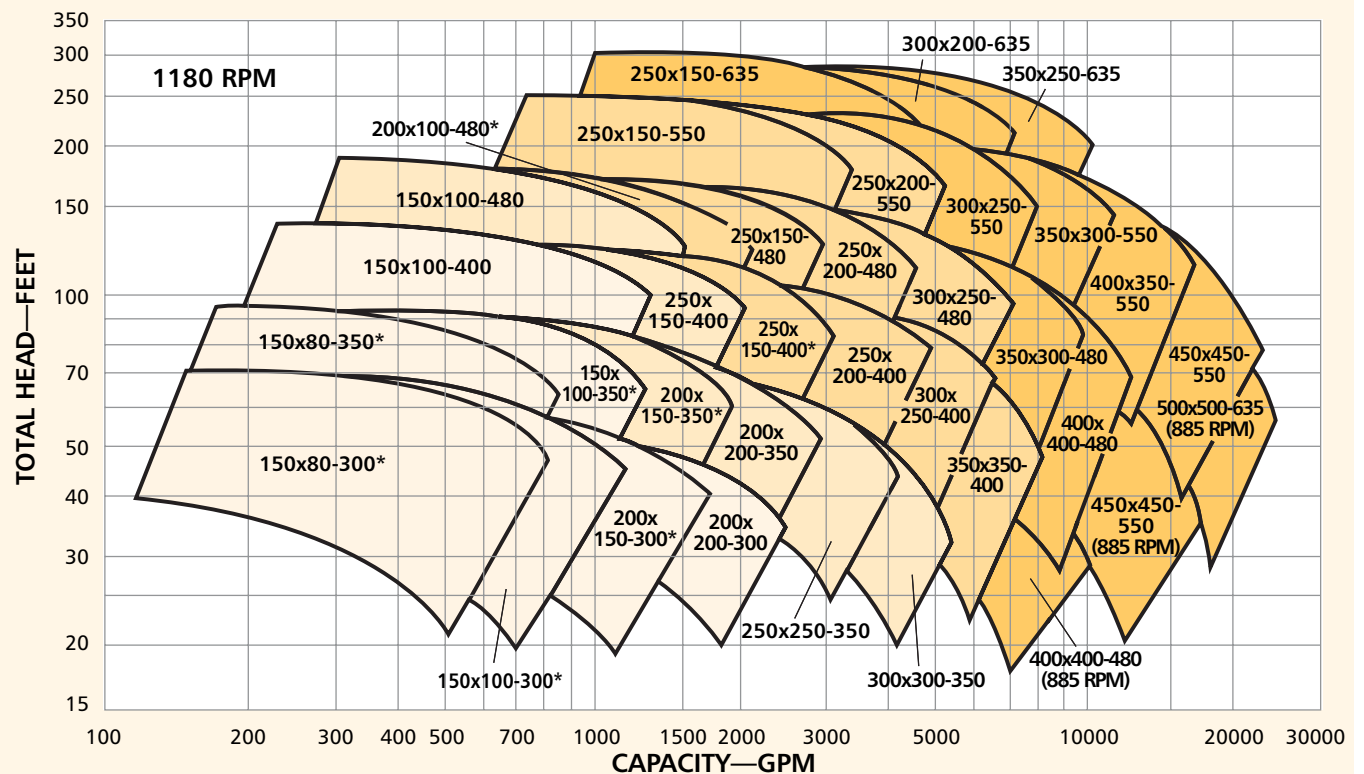
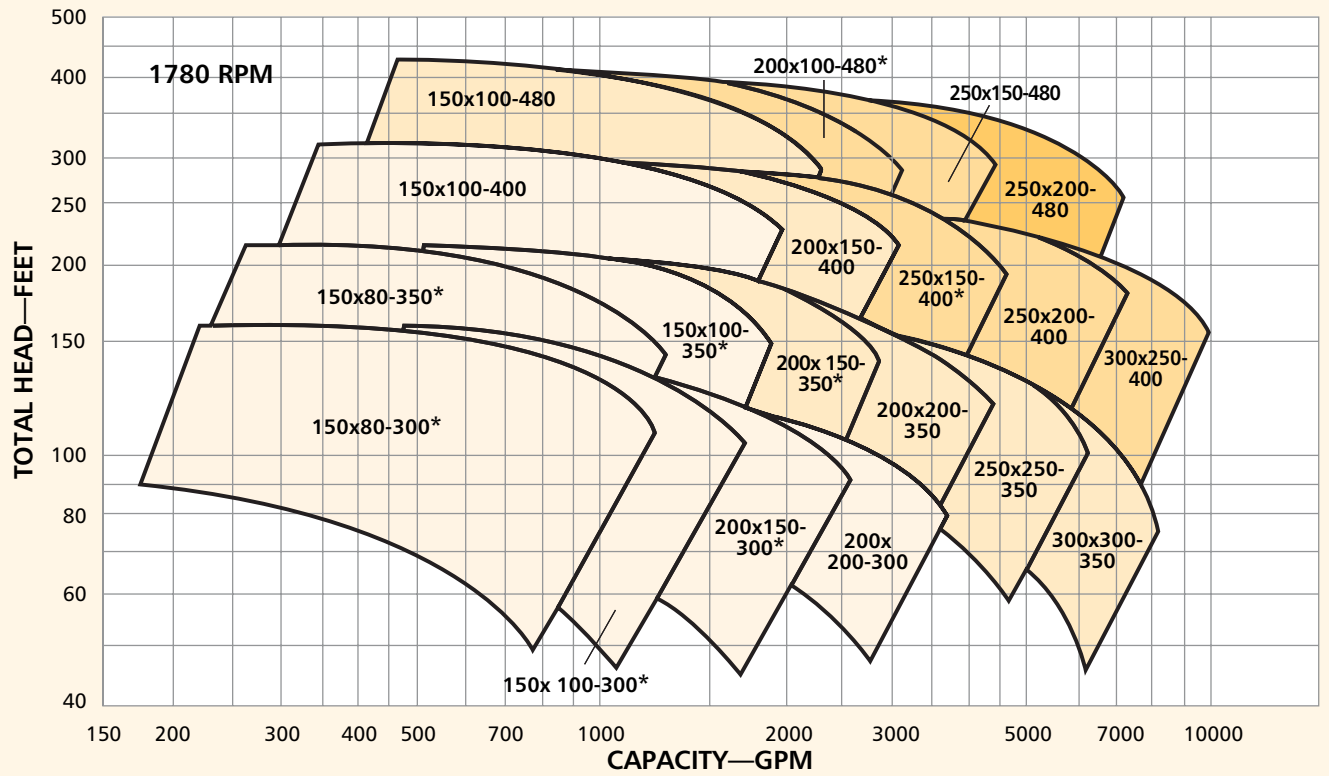

*Available with Shearpeller™

Parts List and Materials of Construction

Item Number	Part Name	Material				
		All Iron/ SS Impeller	All Iron/ SS Impeller, SS Sideplate	All 316SS	All CD4MCuN	All 317SS
100	Casing	Cast Iron	Cast Iron	316SS	CD4MCuN	317SS
101	Impeller (Note 1)	316SS	316SS	316SS	CD4MCuN	317SS
105	Lantern Ring	Teflon®				
106	Packing	Teflon® Impregnated Fibers				
107	Gland	316SS				
112	Thrust Bearing	Duplex Angular Contact				
122	Shaft	Carbon Steel (4340)				
126	Shaft Sleeve	316SS	316SS	316SS	316SS	317SS
126A	Shearpeller™ Sleeve	N/A	Carbon-filled Teflon			N/A
127	Case Wear Ring (Enclosed Impeller)	316SS	316SS	316SS	CD4MCuN	317SS
134A	Bearing Housing	Cast Iron				
136	Bearing Locknut and Lockwasher	Steel				
159	Seal Chamber (Mechanical Seal)	Cast Iron	Cast Iron	316SS	CD4MCuN	317SS
176	Suction Sideplate (Open Impeller)	Cast Iron	316SS	316SS	CD4MCuN	317SS
178	Impeller Key	AISI 303				
184	Stuffing Box Cover (Packed Box)	Cast Iron	Cast Iron	316SS	CD4MCuN	317SS
184A	Stuffing Box Cover (Dynamic Seal Option)	316SS	316SS	316SS	CD4MCuN	317SS
202	Impeller Wear Ring (Enclosed Impeller)	316SS	316SS	316SS	CD4MCuN	317SS
228	Bearing Frame	Cast Iron				
262	Repeller (Dynamic Seal Option)	316SS	316SS	316SS	CD4MCuN	317SS
304	Impeller Nut	316SS	316SS	316SS	CD4MCuN	317SS
332A	Labyrinth Seal, Outboard	Bronze				
333A	Labyrinth Seal, Inboard	Bronze				
351	Casing Gasket	Aramid Fiber with EPDM Rubber				
353	Mechanical Seal	As Required				
358	Casing Drain Plug	Carbon Steel	Carbon Steel	316SS	Alloy 20	317SS
360P	Sideplate-to-Casing Gasket	Aramid Fiber with EPDM Rubber				
409	Radial Bearing	Cylindrical Roller				
412A	O-ring, Impeller	Teflon®				
412C	O-ring, Sideplate-to-Casing	Viton®				
412F	O-ring, Sleeve	Teflon®				
444	Backplate (Dynamic Seal Option)	316SS	316SS	316SS	CD4MCuN	317SS
496	O-ring, Bearing Housing	Buna				
748	Casing Lug	Ductile Iron				

Note 1: Shearpeller™ available only in Duplex 2205.

Materials of Construction

Material	ASTM	Approximate Equivalent Standards		
		DIN	JIS	ISO
Ductile Iron	A536 Gr 60-40-18	0.7043	G5502 FCD40	R1083/400-12
Cast Iron	A48 Class 30B	0.6020	G5501 FC20	DR185/Gr200
316SS	A743 CF-8M	1.4408	G5121 SCS14	
317SS	A743 CG-8M	1.4448		
CD4MCuN	A890 GR1B CD4MCuN	1.4517		
Alloy 20	A743 CN-7M	1.4536		
Duplex 2205	A240	1.4462		

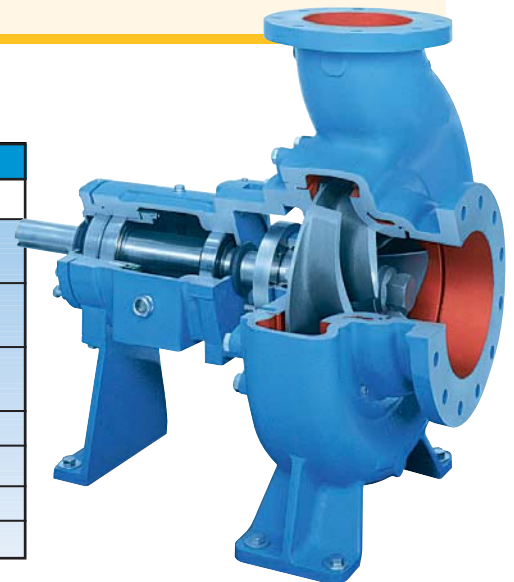

Sectional View

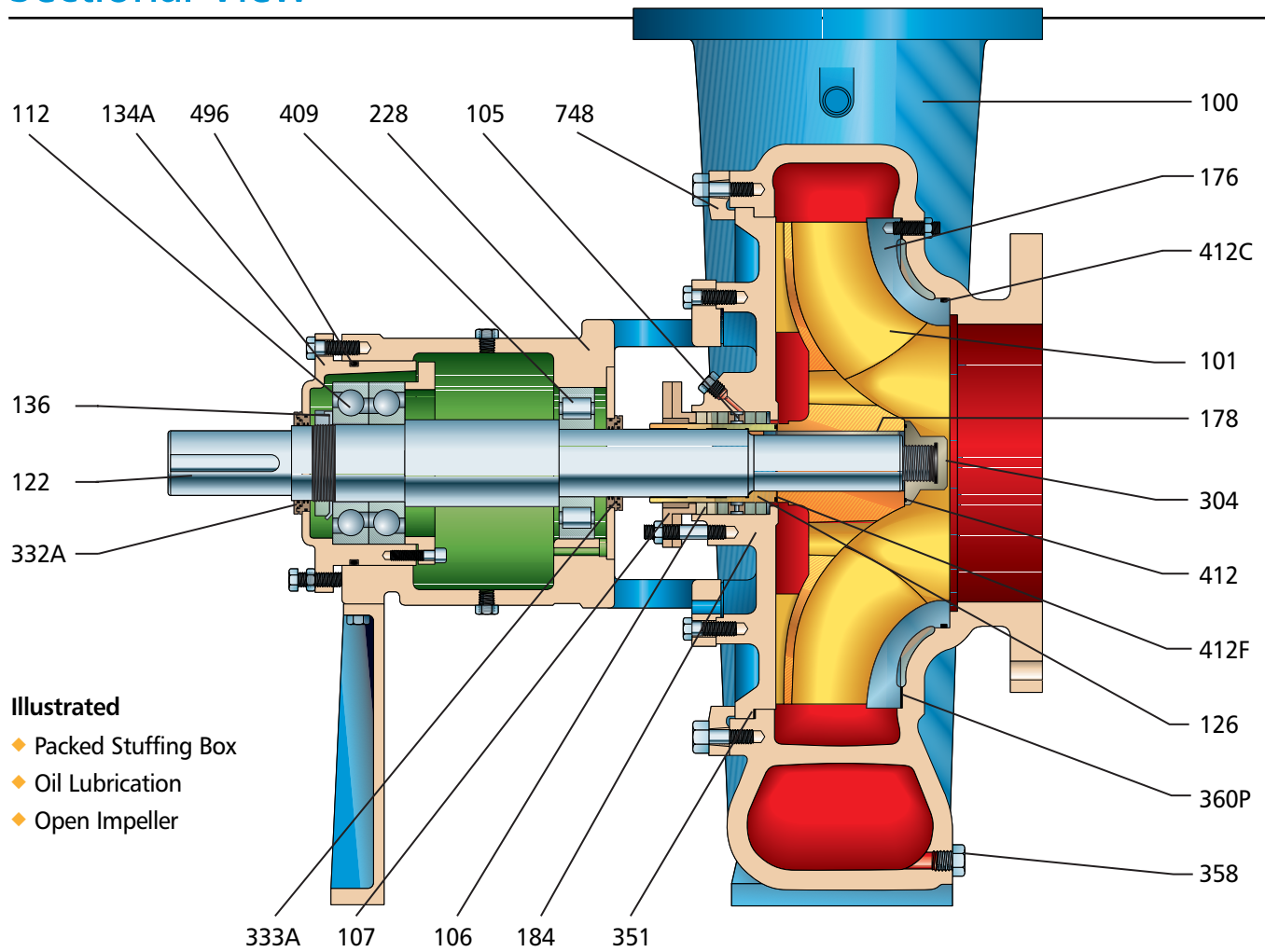

Illustrated

- ◆ Packed Stuffing Box
- ◆ Oil Lubrication
- ◆ Open Impeller

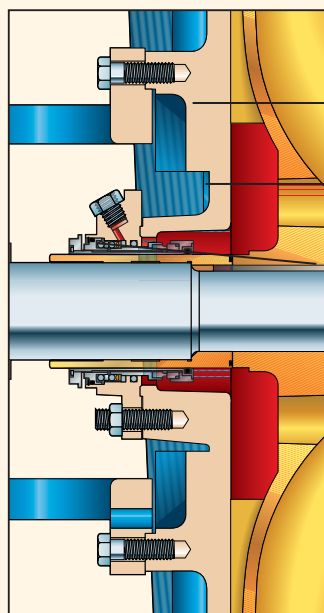

Mechanical Seal Option

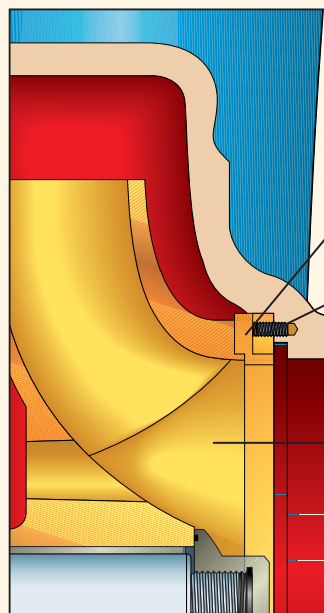

Enclosed Impeller Option

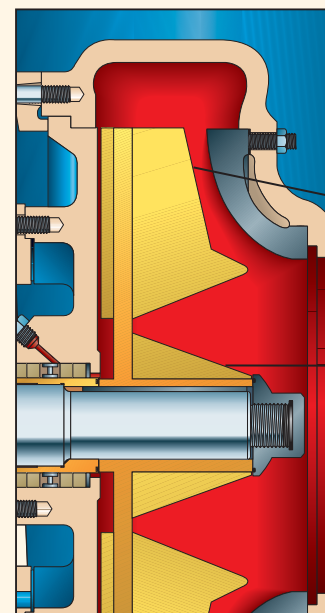

Shearpeller™

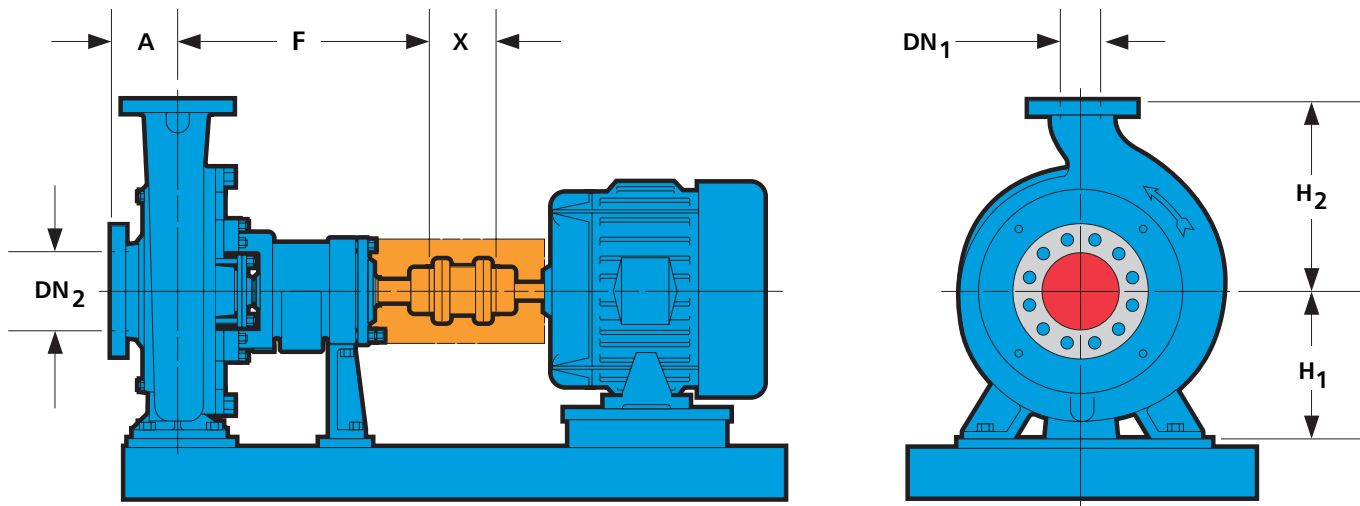

Dimensions All dimensions in mm. Not to be used for construction.

Group	Size	Discharge DN ₁	Suction DN ₂	H ₁	H ₂	A	F	X (minimum)	Pump Weight-kg
S	150X80-300	80	150	250	315	125	530	140	167
	150X100-300	100	150	250	355	140	530	140	176
	200X150-300	150	200	280	375	160	530	140	236
	200X200-300	200	200	315	425	200	530	140	295
	150X80-350	80	150	250	315	125	530	140	212
	150X100-350	100	150	280	355	140	530	140	228
	150X100-400	100	150	315	400	140	530	140	257
M	200X150-350	150	200	315	400	160	670	180	247
	200X200-350	200	200	315	450	180	670	180	281
	250X250-350	250	250	355	475	225	670	180	351
	300X300-350	300	300	425	560	250	670	180	418
	200X150-400	150	200	315	450	160	670	180	284
	150X100-480	100	150	315	425	160	670	180	305
L	250X150-400	150	250	355	500	180	750	180	372
	250X200-400	200	250	425	500	225	750	180	414
	300X250-400	250	300	425	600	265	750	180	489
	350X350-400	350	350	500	670	180	750	180	606
	200X100-480	100	200	355	450	160	750	180	318
	250X150-480	150	250	355	500	180	750	180	420
	250X200-480	200	250	425	560	200	750	180	451
	300X250-480	250	300	425	600	250	750	180	514
	250X150-550	150	250	425	560	180	750	180	493
	250X200-550	200	250	425	600	225	750	180	543
XL	350X300-480	300	350	500	670	280	830	250	698
	400X400-480	400	400	560	750	300	850	250	837
	300X250-550	250	300	500	670	225	830	250	658
	350X300-550	300	350	560	670	265	830	250	763
	400X350-550	350	400	630	750	335	830	250	915
	450X450-550	450	450	630	850	355	850	250	1053
	250X150-635	150	250	425	560	200	830	250	630
	300X200-635	200	300	500	630	225	830	250	687
	350X250-635	250	300	560	750	250	830	250	766
	500X500-635	500	500	750	1000	400	850	250	1216

Modular Interchangeability

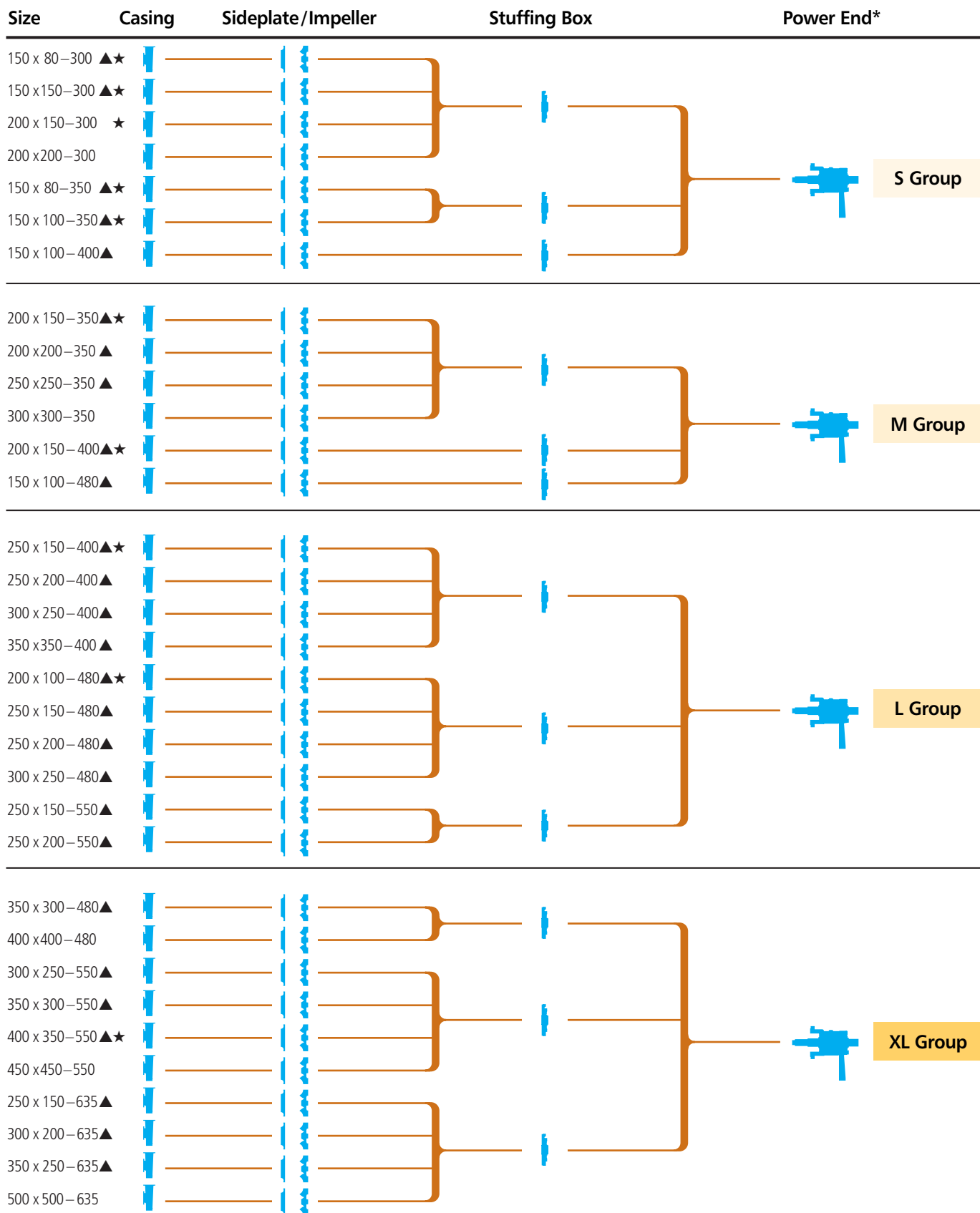

* Shafts for Models 3180 and 3185 are not interchangeable.
 Sleeves for mechanical seals on the 3180 and 3185 are not interchangeable.
 ▲ Available with enclosed impeller.
 ★ Available with Shearpeller™.

Construction Details 3185 (Metric dimensions)

		S Group	M Group	L Group	XL Group
Temperature Limits	Grease Lube	180° C	180° C	180° C	180° C
	Oil Lube w/o cooling	180° C	180° C	180° C	180° C
	Oil lube w/cooling	230° C	230° C	230° C	230° C
Shaft Diameters (mm)	At Impeller	38.5	45	56	66
	Under Shaft Sleeve	50	58	68	80
	At Coupling	42	48	65	75
	Between Bearings	67	73	86	103
Packed Stuffing (mm)	Bore	85	95	105	120
	Depth	85	85	90	90
	Packing Size	12.5	12.5	12.5	12.5
	# of Packing Rings	5	5	5	5
	Width of Lantern Ring	16	16	19	19
	Distance to 1st Obstruction	57	80	70	82
	Sleeve Diameter	60	70	80	95
Mechanical Seal Chamber (mm)	Bore	85.6	98.5	114	127
	Depth to VPE ring	46	61	54.6	54.6
	Distance to 1st Obstruction	73	93	88	101
	Sleeve Diameter	60	70	80	95
Coupling Spacing	Min. req'd for back pull-out	140 mm	180 mm	180 mm	240 mm

Ease of Maintenance



- ◆ High strength casing lugs to secure cover to casing.
- ◆ Lugs swing away without removal during disassembly. Prevents lost or misplaced lugs and casing bolts.
- ◆ Lug can be used as jacking bolt to assist in pump disassembly.
- ◆ Large opening on each side of adapter for easy access to seal and gland.



Monitoring sites

- ◆ Monitoring sites for vibration and temperature are provided as standard for accurate and repeatable readings.
- ◆ Bull's eye sight gauge for accurately monitoring oil level. Also provides visual inspection of oil quality.

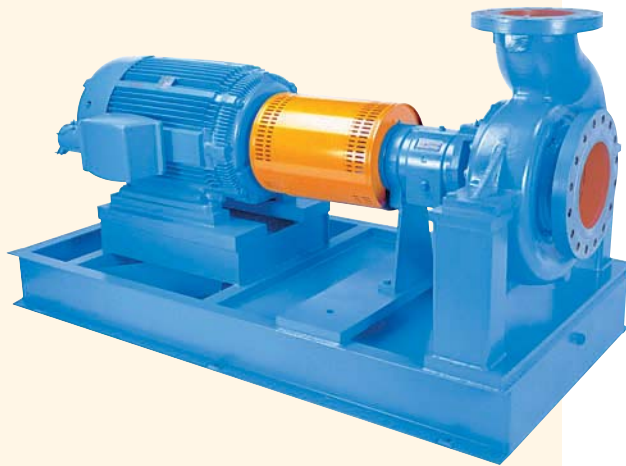

- ◆ Capacities to 3,000 m³/h (13,000 GPM)
- ◆ Heads to 125 m (410 feet)
- ◆ Temperatures to 300°C (508°F)
- ◆ Pressures to 25 bar (360 PSIG)

World-class pump line

Model 3181

- ◆ ANSI Class 300 flange drilling
- ◆ Inch-dimensioned O.D. of mechanical seal sleeve
- ◆ Inch-dimensioned bearing locknut
- ◆ Inch-dimensioned coupling extension

Model 3186

- ◆ ISO or JIS 40 bar flange drilling
- ◆ mm-dimensioned O.D. of mechanical seal sleeve
- ◆ mm-dimensioned bearing locknut
- ◆ mm-dimensioned coupling extension

Goulds 3181/86

Designed to handle high temperature and high pressure services of the pulp & paper industries

Design Features

- ◆ **Hydraulic Coverage** – Line designed for full 50/60 Hz performance.
- ◆ **Back Pull-out Construction** – Spacer type coupling allows one-craft maintenance.
- ◆ **Centerline Supported** – High temperature stability.
- ◆ **Labyrinth Seals** – Eliminate loss of lubricant, prevent lubricant contamination for maximum bearing life.
- ◆ **Maximum Interchangeability** – Power end and impellers completely interchangeable with Goulds Models 3180.
- ◆ **International Design** – Metric fasteners and fittings used throughout.

Services

Digester recirculation

Make-up liquor

White liquor

Black liquor

High pressure/high temperature pulp mill services

Hot oil

Model 3181/86

For high pressure/temperature services

- ◆ Centerline mounted
- ◆ Fully-confined spiral wound-casing basket
- ◆ Through bolted seal chamber

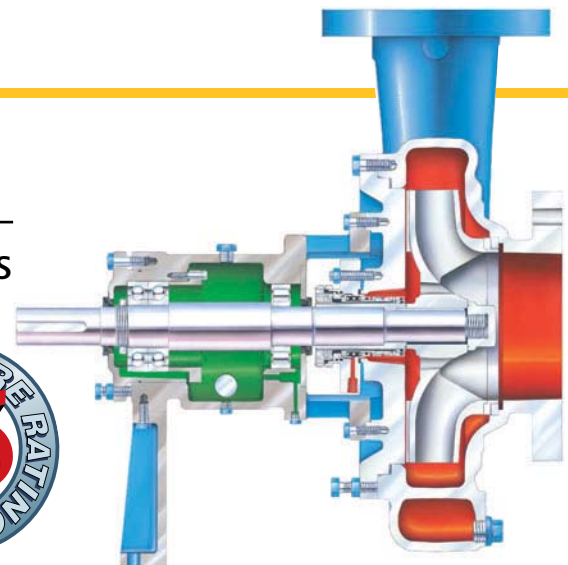



World-class Paper Stock and Medium Consistency Products

Goulds offers a variety of products in various configurations to meet your medium consistency pumping and mixing needs

Standpipe Arrangement with ClO₂ Mixing

Stock from washers and mixers feed special Goulds standpipes that are reverse tapered to prevent stock bridging. Systems include controls for vacuum, dilution, level and flow, ClO₂ Optimix™ mixer and chemical injection pipe are included.



Tower Bottom Arrangement

Stock from bleach / storage towers falls into Goulds feed chute connected to the tower with expansion joint and isolation valve. Depending on tower level and consistency a vacuum pump may not be required.

Booster Arrangement

Goulds booster pump will increase pressure, but does not require standpipe or degassing system.

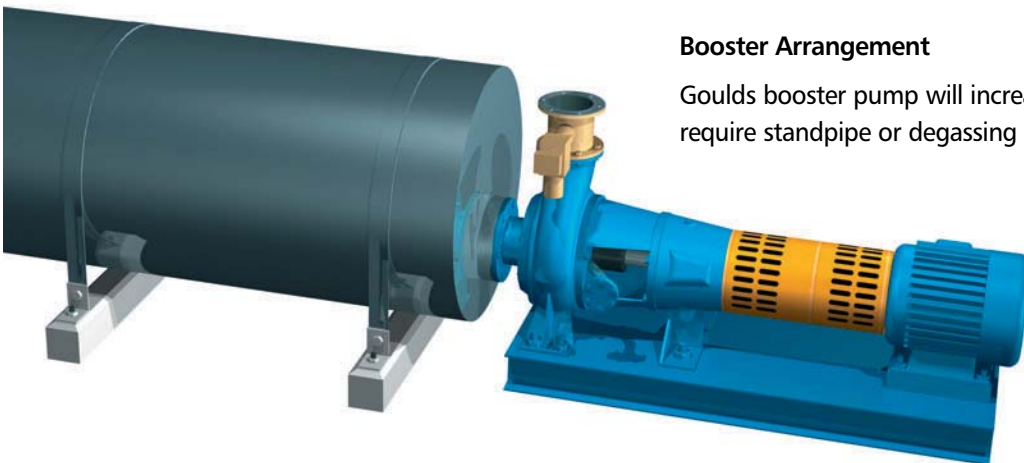

Pick Your Perfect Process Pump

No one in the industry offers the broad range of process pumps that Goulds does!

Whether it's for pumping severe corrosives, abrasive slurries, fibrous/stringy solids, high temperature liquids, hazardous fluids, low flow or high capacity services — Goulds has a perfect, reliable solution. The Goulds selection of pump solutions includes horizontal and vertical configurations in a range of alloy and non-metallic constructions, sealed and sealless.

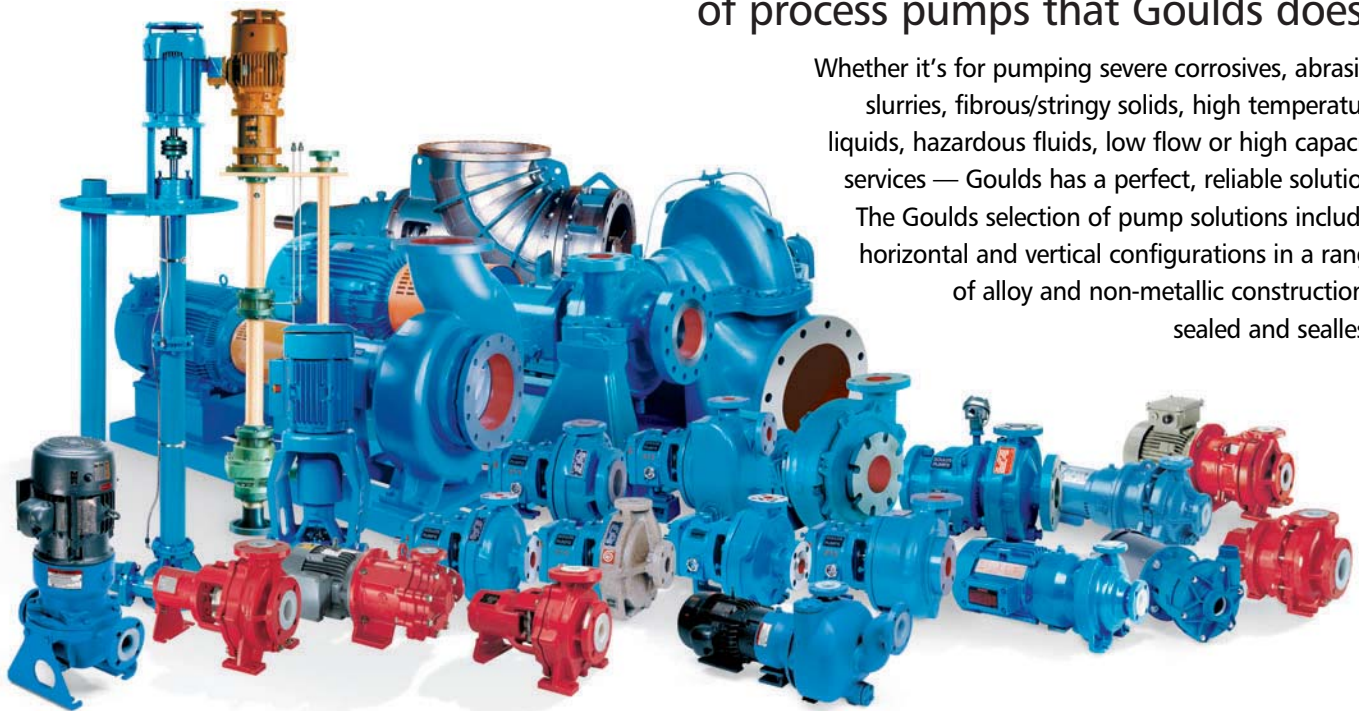

The Pulp and Paper Industry has the widest range of applications of any industry. Goulds wide range of products ensures that we have the right pump for virtually every application.

Mill Area								
Pump Type	Model	Woodyard	Pulp Mill	Bleach Plant	Chemical Recovery	Recycle	Paper Machine	Power House
Paper Stock	3175							
	3180/85							
	3181/86							
Medium Consistency	3500							
	3501							
Chemical Process	3196							
	LF3196							
	IC							
Recessed Impeller	CV3196							
	HS							
Double Suction	3410/3409							
	3415/3420							
Self-Priming & Solids Handling	3796							
	Trash Hog							
	Prime Line							

Mill Area								
Pump Type	Model	Woodyard	Pulp Mill	Bleach Plant	Chemical Recovery	Recycle	Paper Machine	Power House
Sealless	3298							
	3296							
High Temp/Press	3700							
Multi-Stage	3310H							
	3355							
	3600							
Axial Flow	3316							
	AF							
Slurry	JC							
	SRL							
Submersible	HSU							
	JCU							
Vertical Pump	VHS							
	3171							
Vertical Turbine	VIT							
	VIC							

Member of



PRO Services®
 Extending
 Equipment Life...

Product Repair (all types and brands of rotating equipment)

- Service Center Repair
- Field Service
- Parts Supply

Reliability Improvement

- Inventory Management
- Replacement/Exchange
- Turnkey Repair/Installation
- Training

Optimization of Assets

- Predictive Analysis/Condition Monitoring
 - Root Cause Failure Analysis
 - Pump & System Assessments
 - Upgrades – Mechanical & Hydraulic
 - Maintenance Management/Contract Maintenance
-
- Technical Expertise
 - Factory Trained Service Personnel
 - Quality
 - Fast Turnaround
 - Emergency Service – 24 hours/day, 7 days/week
 - ISO and Safety Certified

PROSMART

ProSmart™ encompasses the latest technology* in condition monitoring to transform your Predictive Maintenance program into a Plant Profitability program. It provides a cost-effective



solution to maintaining uptime on all of your rotating equipment. ProSmart continuously monitors, analyzes and announces an alarm when critical criteria is not met. By identifying, diagnosing, and sounding an alert to potential equipment problems before they have a chance to manifest into unexpected downtime or catastrophic failure, ProSmart helps to assure plant profitability.



ProSmart delivers benefits that go right to the bottom line.

- Extends equipment life
- Optimizes costly “walk arounds” by skilled personnel
- Can help reduce overall equipment failures and the cost of downtime
- Sends alerts prior to potential catastrophic process failures
- Automatically alerts personnel to machine problems.
- Consolidates data for equipment optimization (*Patent pending)

ProSmart is a wireless machinery monitoring system that collects and analyzes operating data automatically every 5 seconds. Integrated analysis capabilities provide enhanced data and reporting functions.

PUMPSMART

PumpSmart® is the latest advancement in pump control and protection to reduce energy consumption, increase uptime and decrease maintenance cost. It allows the pump to be right-sized to the application by dialing in the speed and torque which increases flow economy, reduces heat and vibration and improves overall system reliability.

- **Simplified Pump Control** — PumpSmart was designed specifically to optimize pumping applications and can be used to control a single pump or coordinate between multiple pumps with out the need for an external controller.
- **Pump Protection** — PumpSmart guarantees to protect the pump from upset conditions with patented sensorless pump protection algorithms.
- **SMARTFLOW** — PumpSmart features a sensorless flow function for centrifugal pumps that can calculate the flow of the pump with in ±5% of the pump rated flow.
- **Drive for the DCS** — While most VFDs can only provide basic information PumpSmart offers unparalleled insight to the pump operation which allows for smoother process control and efficiency.
- **Pump Experts** — PumpSmart is a variable speed drive with pump specific algorithms imbedded into the drive. With over 150 years of pump knowledge let the pump experts take responsibility of your pump system.



motralec

4 rue Lavoisier . ZA Lavoisier . 95223 HERBLAY CEDEX
 Tel. : 01.39.97.65.10 / Fax. : 01.39.97.68.48
 Demande de prix / e-mail : service-commercial@motralec.com

