

# Goulds 3298

Chemical Process Pumps



# Goulds 3298

## Chemical Process Pumps

---

- ◆ Capacities to 1,200 GPM (270 m<sup>3</sup>/h)
- ◆ Heads to 350 feet (162m)
- ◆ Temperatures to 250° F (121° C)
- ◆ Pressures to 225 PSIG (1551 kPa)

## Performance Features for Chemical Services

---

- ◆ **Extended Pump Life**
  - Tefzel® (ETFE) Construction
  - Sealless Design
  - Stationary Silicon Carbide Shaft
  - Optional Silicon Carbide Dryguard™ Bearings
- ◆ **Optimum Performance**
  - Non-slip Synchronous Drive
  - Efficiency Equivalent to Sealed ANSI Pumps, 30% Higher than Metal Sealless Pumps
- ◆ **Ease of Maintenance**
  - Minimum Parts
  - No Pump/Motor Alignment Required with Close-Coupled Design
  - ANSI Dimensional
  - Optional Frame-Mounted Design
  - No Mechanical Seal
- ◆ **Safety**
  - Drive and Driven Magnet Assembly Safety Clearances (Frame-Mounted Design)
  - Adapter and Casing Drain Connections
  - Zero Emissions

## Services

---

- Hydrochloric Acid
- Sodium Sulfate
- Sodium Hypochlorite
- Methane
- Sodium Hydroxide
- Sulfuric Acid

## Applications

---

- Rail Car or Tank Unloading
- Batch Chemical Processes
- Specialty Chemicals
- Column Reflux or Bottoms
- Reactor Feed



3298 Close-Coupled  
Standard Design



SP 3298 Self-Priming



V 3298 Space-Saving Vertical In-Line

## Ideal for Moderate to Severe Corrosives!

The 3298 can handle the tough chemical services. As a sealless design, it's an effective alternative to pumps with mechanical seal problems. Meets strictest EPA regulations.



# 3298 Chemical Process Pumps

## Design Features for Wide Range of Process Services

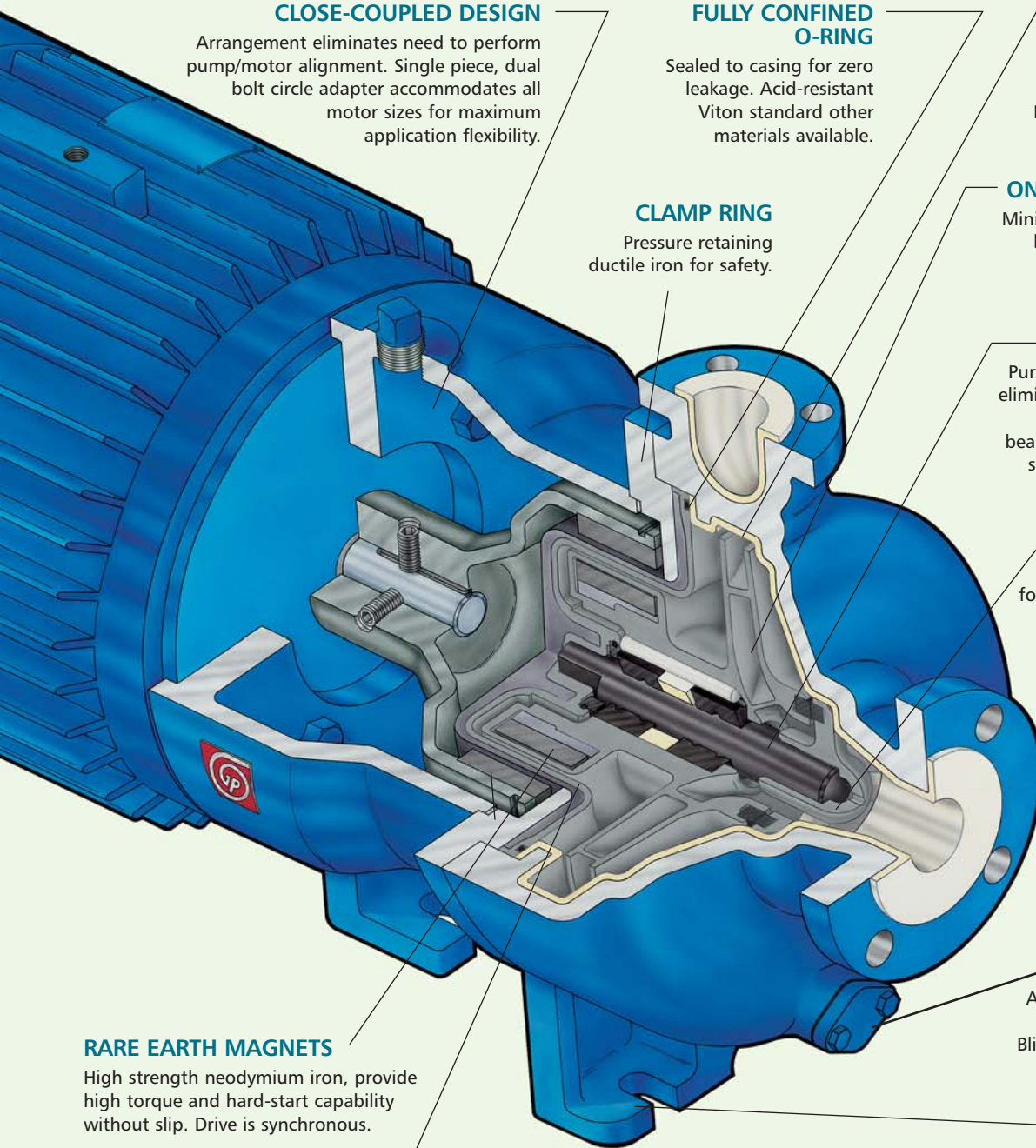

### CLOSE-COUPLED DESIGN

Arrangement eliminates need to perform pump/motor alignment. Single piece, dual bolt circle adapter accommodates all motor sizes for maximum application flexibility.

### FULLY CONFINED O-RING

Sealed to casing for zero leakage. Acid-resistant Viton standard other materials available.

### TEFZEL\* LINING WITH DUCTILE IRON CASING

One-piece solid casing lined with minimum 1/8 inch (3 mm) TEFZEL\*. Rotolining process assures mechanical integrity of lining.

### CLAMP RING

Pressure retaining ductile iron for safety.

### ONE-PIECE ENCLOSED IMPELLER

Minimizes axial thrust for extended thrust bearing life. Unlike two-piece designs, one-piece construction eliminates possibility of front shroud failure.

### SOLID STATIONARY SHAFT

Pure sintered silicon carbide construction eliminates shaft deflection. Fully supported stationary design maximizes radial bearing life. Straight geometry eliminates stress concentrations and possibility of failure during pump operation

### BEARING SPIDER

Fully supports Silicon Carbide shaft for maximum shaft rigidity. Protects the end of the Silicon Carbide shaft from damage. Smooth hydraulic flow path into the eye of the impeller, equal to that of a standard ANSI pump. Rounded spider hub and spider supports (flow straighteners) reduce turbulence and pre-rotation for better hydraulic stability.

### ANSI DIMENSIONS

Allows easy retrofit of problem ANSI pumps.

### CASING DRAIN

Allows complete draining of fluid from pump for system maintenance. Blind flange and gasket ensure leak-free seal for safety.

### RARE EARTH MAGNETS

High strength neodymium iron, provide high torque and hard-start capability without slip. Drive is synchronous.

### CONTAINMENT SHELL

TEFZEL\* lining with glass reinforced vinylester backing. Rugged design with burst pressure greater than 500 psi. Non-metallic construction provides efficiencies same as sealed ANSI pumps. (30% higher efficiencies than metal sealless pumps.)

### RADIAL BEARING WITH TEFLON\* SPACER

Two-piece design with Teflon\* spacer allows bearings to self-align under load. Independent movement maximizes bearing life. Carbon bearing construction standard; silicon carbide and Dryguard™ optional.

### BEARING LUBRICATION

Generous passageways in the magnet and bearing circuit result in the smallest possible pressure drop across the bearings. This maximizes the flow rate and the pressure in the critical bearing area to prevent vaporization and loss of hydraulic bearing support. Unique vane geometry in the containment shell coupled with dynamic grooves in the bearings prevents solids from getting trapped and accumulating in the circulation path. Can pass 5% (by weight) soft solids up to 160 microns. Other pump designs will 'choke' on small solids due to tight clearances with multiple static flow paths.

### RIGID CASING FEET

Reduce effect of pipe loads on pump and motor shaft alignment.

### TEFZEL\* (ETFE) CONSTRUCTION

Provides superior corrosion resistance; inert to most chemicals. Tough material for superior solids handling/abrasion resistance (same or better than 316 SS).

\*E.I. DuPont Reg. Trademark



## Exceptional Performance for Chemical Services

### 10X More Dry Run Protection

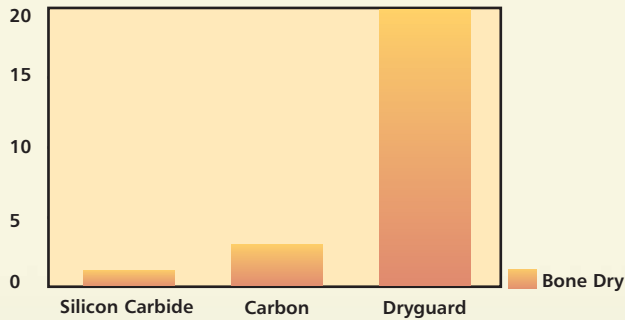

### 10X More Dry Run Protection with Dryguard™ Bearings

Goulds unique Dryguard™ diamond-like carbon coating significantly reduces the coefficient of friction enabling periods of safe operation under dry run conditions. Dryguard™ is up to 1.5X harder than silicon carbide, ensuring its protection lasts throughout the life of the pump.



### Power Monitors

No pump is designed to run dry for an extended period of time. Goulds recommends that pumps be protected with a power monitor. Easy to install and easy to operate, power monitors will ensure extended time between planned maintenance for the 3298 or any other pump in the facility.

### Ultimate Protection

Magnetic drive pump failures are often due to dry running and closed discharge valve conditions. With Dryguard™ silicon carbide bearings and a power monitor, you have the best protection technology can offer. Goulds always recommends the use of a power monitor because... **FAILURE IS NOT AN OPTION!**

### TEFZEL® Construction for Extreme Corrosion Resistance

TEFZEL® (ETFE) is inert to most chemicals, and has good abrasion resistance. TEFZEL® lined casing and containment shell with solid TEFZEL® impeller provide superior corrosion resistance and long life unequalled by alloy pumps.



### Installation/Pump Replacement Flexibility

The 3298 is available in close-coupled or frame-mounted designs for true installation or pump replacement flexibility.

Since the 3298 meets ANSI dimensional standards, retrofitting mechanically sealed ANSI pumps is easy: simply replace the old pump with the equivalent close-coupled or frame-mounted ANSI size 3298.

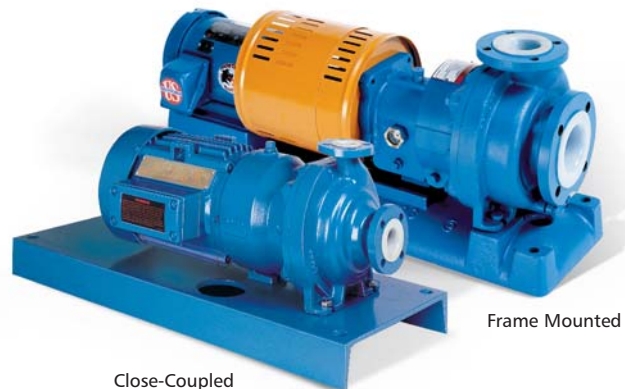

Close-Coupled

Frame Mounted

## Reliable, Simple – Easy To Maintain

### Design Features for Extended Pump Life



- △ Casing with TEFZEL® Lining**  
 One-piece solid ductile iron casing with Tefzel® lining. Generous lining thickness of 1/8 inch (3 mm). Rotolining process assures integrity of lining. Rugged foot mounted design provides maximum resistance to and distortion from pipe loads. Flange loads are the same as metal ANSI pumps. Casing drain allows complete evacuation of pump fluid.

### Radial and Thrust Bearings ▽

Multiple materials available to best suit your pumping application: Carbon, pure sintered Silicon-Carbide or Dryguard™. All rotating bearings are designed with flow grooves to help circulate fluid over the bearings and to help flush solids away. Dryguard™ option keeps your pump running when temporary dry run conditions exist. Forgiving hydraulic design and positive axial thrust allow the pump to get through dry run conditions without damage to other components.



### Stationary Shaft △

Silicon carbide construction eliminates shaft deflection. Fully supported stationary design maximizes radial bearing life.



### △ Containment Shell

TEFZEL® lining with glass reinforced vinylester backing. Burst pressure greater than 500 psig. Fully confined O-ring seals containment shell to casing. Non-metallic construction provides efficiencies same or better than sealed ANSI pumps; 30% higher efficiencies than metal sealless pumps. Non-metallic construction eliminates magnet losses and heat generation. Heat sensitive liquids are easily pumped.

### △ Enclosed One-Piece Impeller/Magnet Assembly

Enclosed design minimizes axial thrust, extends thrust bearing life. One-piece construction eliminates front shroud failure possible with two-piece impellers. Neodymium iron magnets are molded in place, reducing the chance of permeation.

## Extreme Ease of Maintenance

### Design Concept

The 3298 design concept is simple — few parts and only one bolt size. One-craft maintenance is all that's required — with one wrench! Planned maintenance is fast and easier than other process pumps – sealed or sealless. Standard close-coupled model eliminates need to perform time consuming pump and motor alignment.



### Simple Operation

Unlike most magnetic drive pumps, the 3298 is as easy to operate as any standard ANSI pump. Non-metallic construction with no heat build-up makes the 3298 ideally suited for tank transfer, tank unloading, or any batch type service.

### Zero Leakage

The 3298 is sealless and environmentally safe. No mechanical seal assures zero leakage on moderate to severe corrosives, hazardous liquids.

A great solution to pumps with mechanical seal problems.



# Parts List and Materials of Construction

Item Number	Part Name	Material
100	Casing	Ductile Iron/TEFZEL*
101	Impeller Assembly	TEFZEL
101A	Bearing Spider	TEFZEL/Silicon Carbide, Optional-TEFZEL/Dryguard™
109A	Bearing End Cover (Frame-Mounted)	Ductile Iron
112	Ball Bearing (Frame-Mounted)	Steel
113A	Plug-Oil Fill (Frame-Mounted)	Steel
122A	Stationary Shaft	Silicon Carbide, Optional-Dryguard™
122B	Drive Shaft (Frame-Mounted)	Steel
141C	Clamp Ring	Ductile Iron
144A	Rub Ring (M&L Frame-Mounted)	Cast Iron
157A	Bearing Spacer-Radial	TEFLON*
178S	Key, Impeller to Bearings	TEFLON
178Y	Key, Drive Carrier	Steel
197B	Radial Bearing	Standard-Carbon Graphite, Optional-Silicon Carbide or Dryguard™
197C	Bearing, Reverse Thrust	Carbon-Filled TEFLON
197D	Bearing, Impeller Thrust	Standard-Carbon-Filled TEFLON, Optional-Silicon Carbide or Dryguard™
203	Rear Impeller Wear Ring (M and L Group only)	Carbon-Filled TEFLON
222L	Set Screw (Close-Coupled)	Steel
228	Frame	Cast Iron
241	Frame Foot	Cast Iron
314H	Retaining Ring, Impeller/Driven Magnet Assembly	TEFZEL
332A	Labyrinth Seal (Frame-Mounted)	Carbon-Filled TEFLON
333D	Lip Seal (Frame-Mounted)	Buna Rubber
351G	Gasket, Case Drain	Gylon
355A	Hex Nut (Frame-Mounted)	Steel
356A	Hex Cap Screw-Clamp Ring to Case	304 Stainless Steel
358	Flange, Case Drain	Steel
360A	Gasket-Bearing End Cover to Frame (Frame-Mounted)	Varnished Kraft
360W	Gasket-Frame to Clamp Ring	Aramid Fibers with EPDM Rubber
361H	Retaining Ring (L Group Only)	TEFLON Encapsulated Silicon
370B	Hex Cap Screw-Frame to Clamp Ring	304 Stainless Steel
370C	Hex Cap Screw-End Cover to Frame (Frame-Mounted)	304 Stainless Steel
370F	Hex Cap Screw-Frame Foot	304 Stainless Steel
372Y	Hex Cap Screw-Frame To Rub Ring (M & L Group Only)	304 Stainless Steel
412M	O-ring-Containment Shell	Standard-Viton, Optional-EPDM, Optional-Viton Encapsulated in TEFLON
418	Hex Tap Bolt-Jacking (M & L Group Only)	304 Stainless Steel
426A	Hex Cap Screw-Case Drain	304 Stainless Steel
496D	O-ring-Reverse Thrust Bearing	Viton Encapsulated in TEFLON
529	Washer, Wave Spring (L Group Only)	Steel
740A	Driven Magnet Assembly (L Group Only)	TEFZEL Neodymium Iron
740B	Drive Carrier Assembly	Cast Iron/Neodymium Iron
750	Containment Shell	TEFZEL/Fiber Reinforced Vinyl Ester

\*Registered trademarks for fluoropolymer resins, films and fibers made by DuPont.

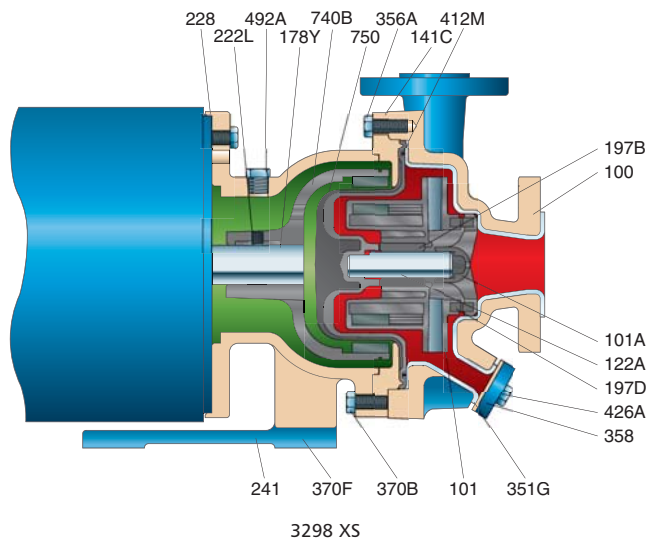

The 3298 S provides additional low flow coverage below the hydraulics of the smallest traditional ANSI pump size. XS pumps meet user requirements for low flow capabilities. Applying an oversized ANSI pump is not required.

- ◆ Capacities to 120 GPM (27 m3/h)
- ◆ Heads to 160 feet (49 m)
- ◆ Temperatures to 250° F (121° C)
- ◆ Pressures to 150 PSIG (1034 kPa)

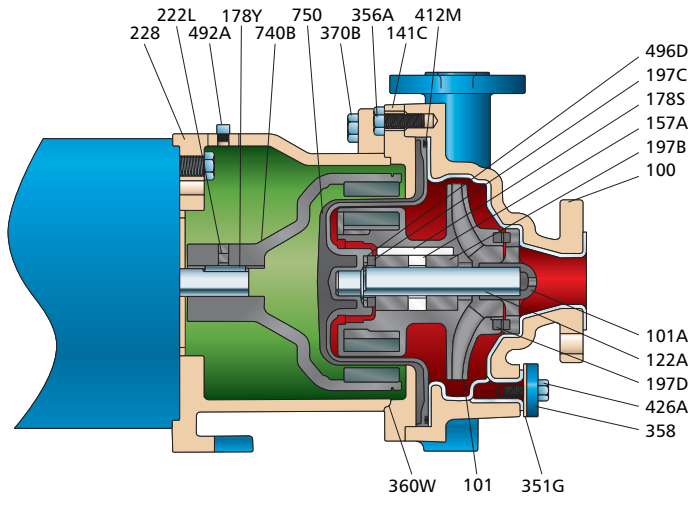

3298 S Close-Coupled

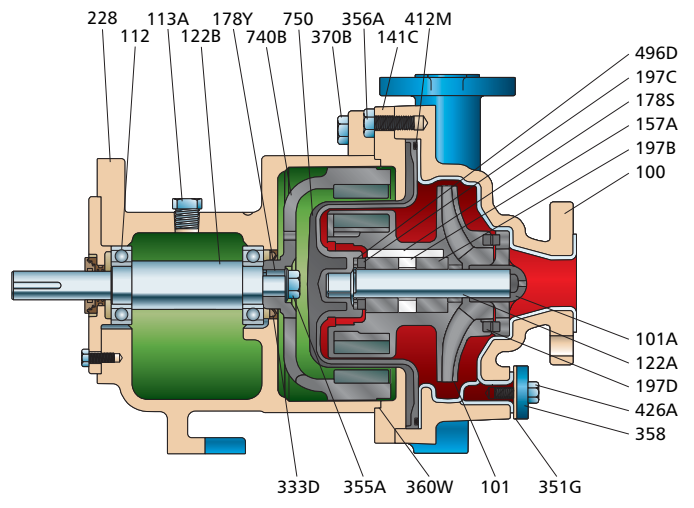

3298 S Frame-Mounted

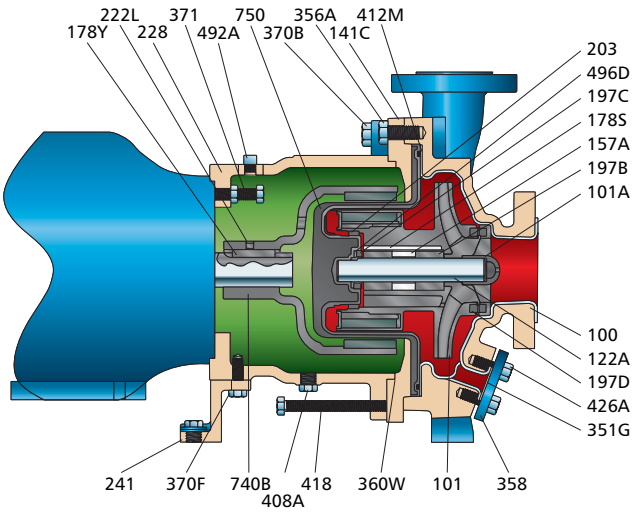

3298 M Close-Coupled

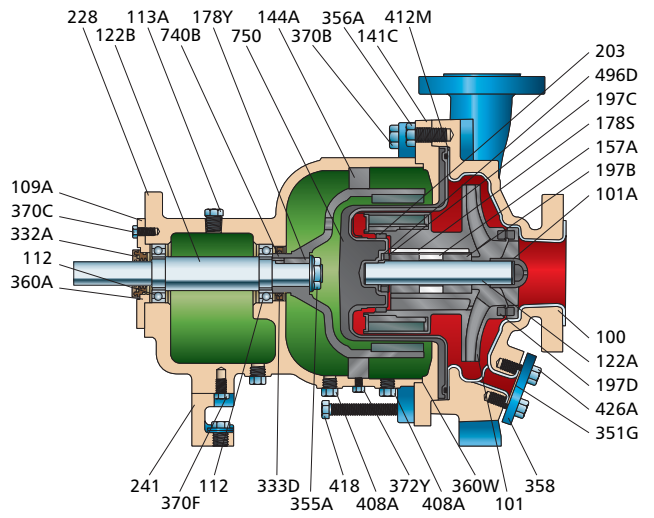

3298 M Frame-Mounted

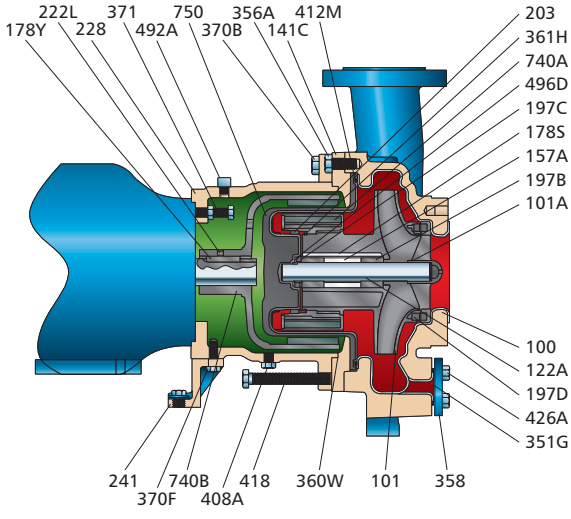

3298 L Close-Coupled

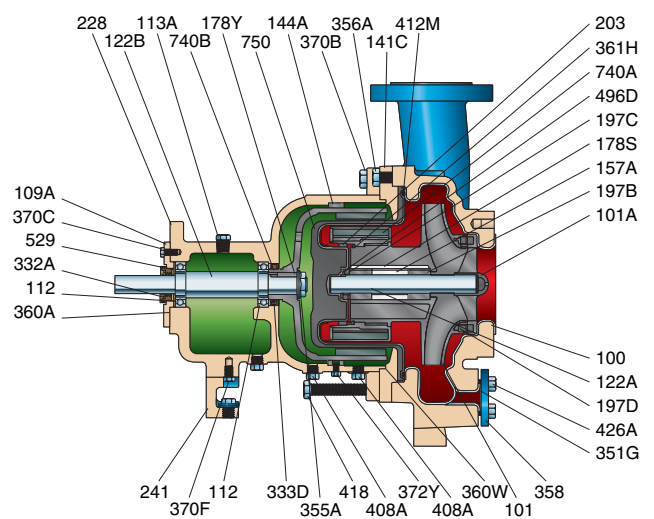

3298 L Frame-Mounted



# Hydraulic Coverage Model 3298

All dimensions in inches and (mm). Not to be used for construction.

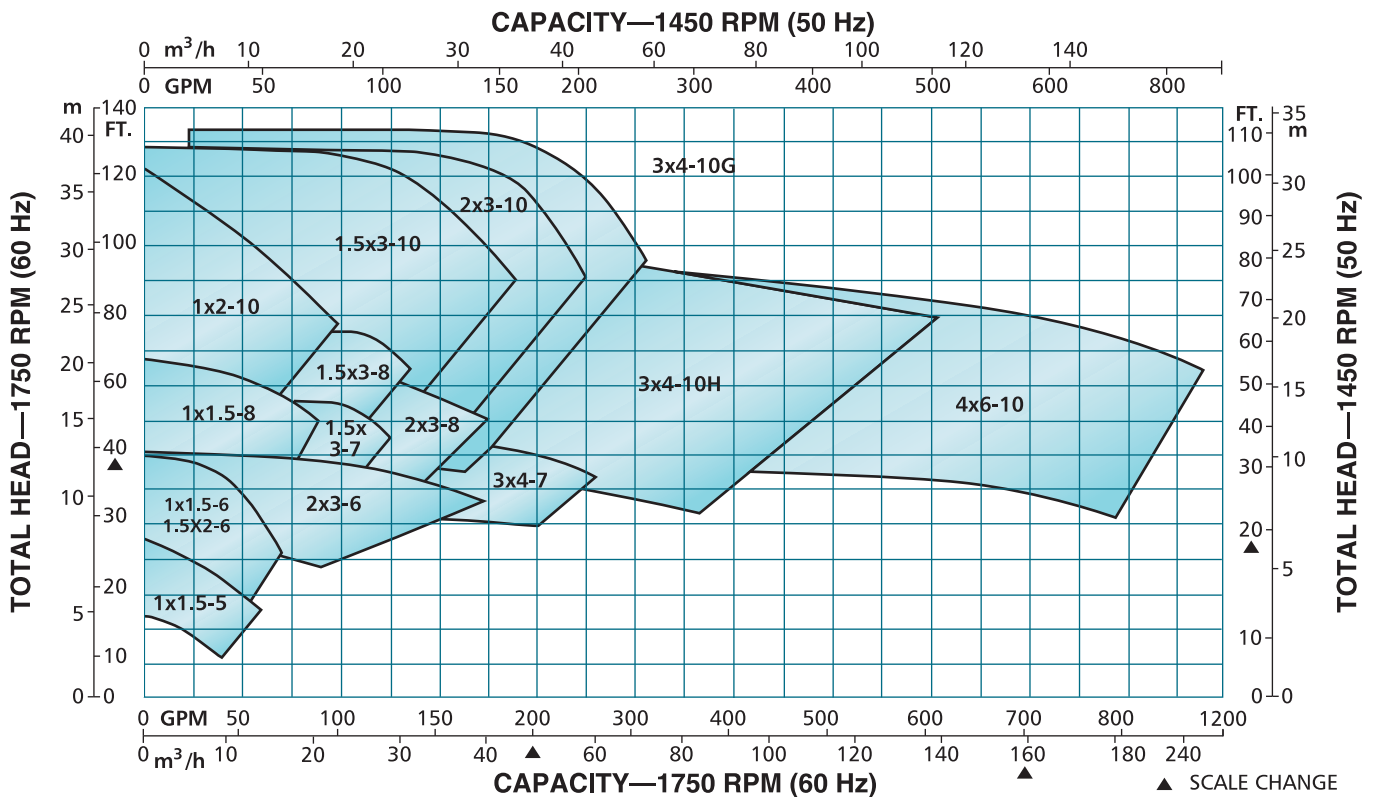
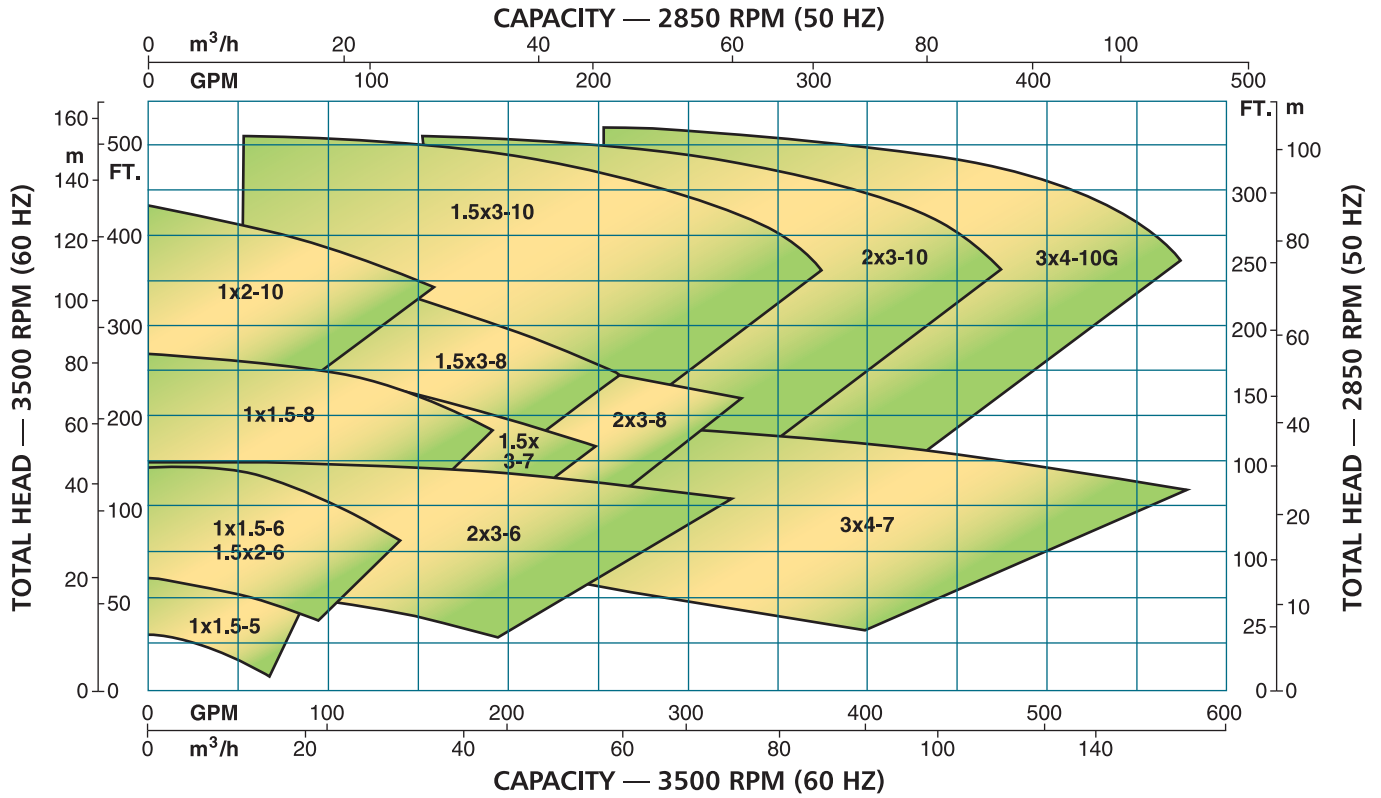



# Dimensions Model 3298

All dimensions in inches and (mm). Not to be used for construction.

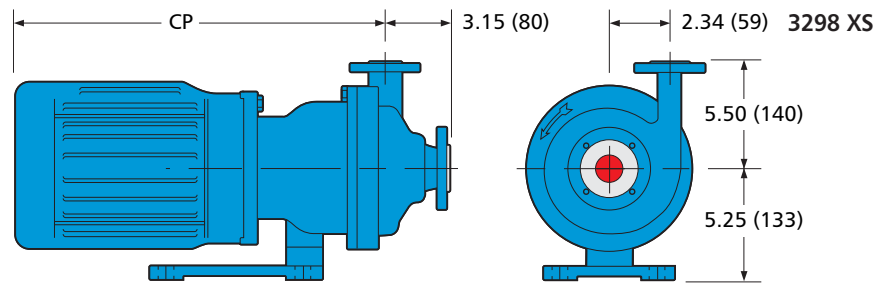

Dimensions (1 x 1 1/2 - 5)							
Group	Size	Motor Frame	CP (Approx.)	Motor Weight lb (kg)	Pump Weight lb (kg)	Y	Z
XS	1 x 1.5-5	56C	16.9 (429)	45 (21)	46 (21)	3.15 (80)	2.34 (59)
		143-145TC	18.9 (480)	65 (30)			
		182-184TC	19.9 (505)	105 (48)			
	1.5 x 2-6	56C	16.6 (422)	45 (21)	60 (27)	3.41 (87)	2.56 (65)
		143-145TC	18.6 (472)	65 (30)			
		182-184TC	19.6 (498)	105 (48)			
		213-215TC	25.0 (635)	150 (68)			

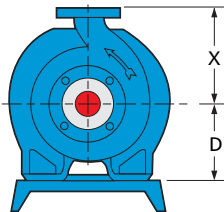
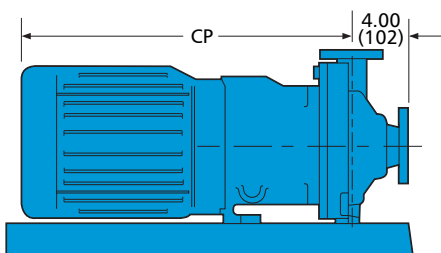

3298 Close-Coupled Design

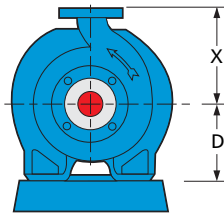
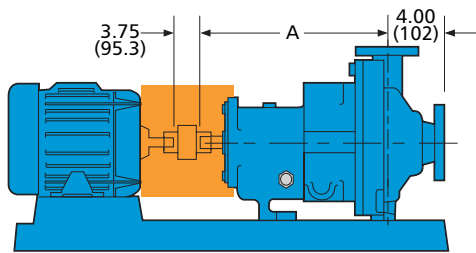

3298 Frame-Mounted Design

Close-Coupled		
Motor Frame	Group	CP (Approx.)
143TC	S	19 (483)
	M	NA
	L	NA
145TC	S	18 (457)
	M	NA
	L	NA
182TC/184TC	S	22.1 (562)
	M	25 (635)
	L	NA
213TC/215TC	S	25.6 (651)
	M	28.5 (724)
	L	NA
254TC/256TC	S	30.1 (765)
	M	33 (838)
	L	NA
284TSC/286TSC	S	NA
	M	37 (940)
	L	NA
324TSC/326TSC	S	NA
	M	40 (1016)
	L	NA
364TSC	S	NA
	M	NA
	L	42.5 (1080)

Bare Pump Dimensions						
Group	Size	A	D	X	Close-Coupled	Frame Mounted
S	1 x 1.5-6	13.50 (34.3)	5.25 (133)	6.50 (165)	68 (31 kg)	97 (44 kg)
	2 x 3-6				79 (36 kg)	108 (49 kg)
	1 x 1.5-8				84 (38 kg)	113 (52 kg)
	1.5 x 3-7				89 (41 kg)	118 (54 kg)
M	1 x 2-10	19.50 (495)	8.25 (210)	8.47 (215)	170 (78 kg)	190 (87 kg)
	1.5 x 3-8				176 (80 kg)	194 (88 kg)
	2 x 3-8				178 (81 kg)	196 (90 kg)
	3 x 4-7				193 (89 kg)	214 (98 kg)
L	1.5 x 3-10	19.50 (495)	10.00 (254)	8.47 (215)	180 (82 kg)	203 (92 kg)
	2 x 3-10				184 (84 kg)	207 (94 kg)
	3 x 4-10G				198 (91 kg)	221 (102 kg)
	3 x 4-10H				198 (91 kg)	221 (102 kg)
	4 x 6-10				223 (103 kg)	249 (115 kg)

## Model SP 3298 for Self-Priming Applications

When suction lift conditions exist, air must be evacuated to effectively prime the pump. This air or vapor must be expelled each time the pump is started. The Goulds design incorporates a highly reliable one-piece casing without the use of an internal check valve or external gooseneck.

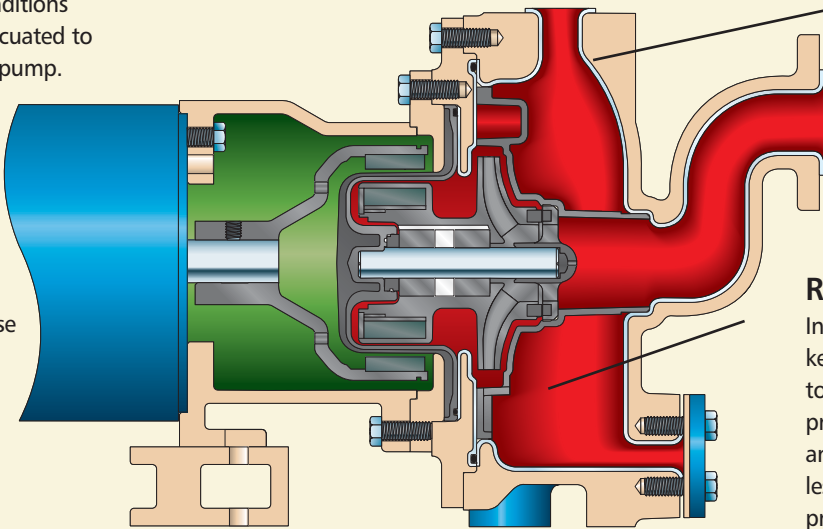

### Optimally-sized Casing

Retains enough liquid to prime but not too much to increase fluid temperature during priming. Temperature rise is half of the competition.

### Retained Liquid

Integrated suction gooseneck keeps all bearings fully submerged to ensure lubrication during priming cycles. By minimizing the amount of retained liquid, there is less churning of the liquid during priming, thus, minimizing temperature rise during priming.

## Design Features for Superior Self-Priming Performance

### One-Piece Casing without Check Valve ▷

Provides reliable priming in all conditions. Eliminates the additional gooseneck component found on other brands. Retains proper amount of liquid in casing to prime without the use of a troublesome check valve. Check valves are commonly used to retain liquid in the casing to assist in priming on successive uses. However, these check valves wear quickly and contribute additional losses on the suction side due to induced drag. Goulds has eliminated the check valve and the SP 3298 out performs our competition in priming times.

### The Volute Insert ▷

Completes the self-priming design. The volute separates the air from the liquid, expels the air through the discharge, and returns the liquid to the suction until all the air is removed and the pump is operating like a standard centrifugal pump.



## For Ease of Maintenance

### Parts Interchangeability

All components fully interchangeable with 3298 and V 3298, except the casing, volute insert, and backplate. Reduces spare parts inventory requirements.

# Dimensions Model SP 3298

All dimensions in inches and (mm). Not to be used for construction.

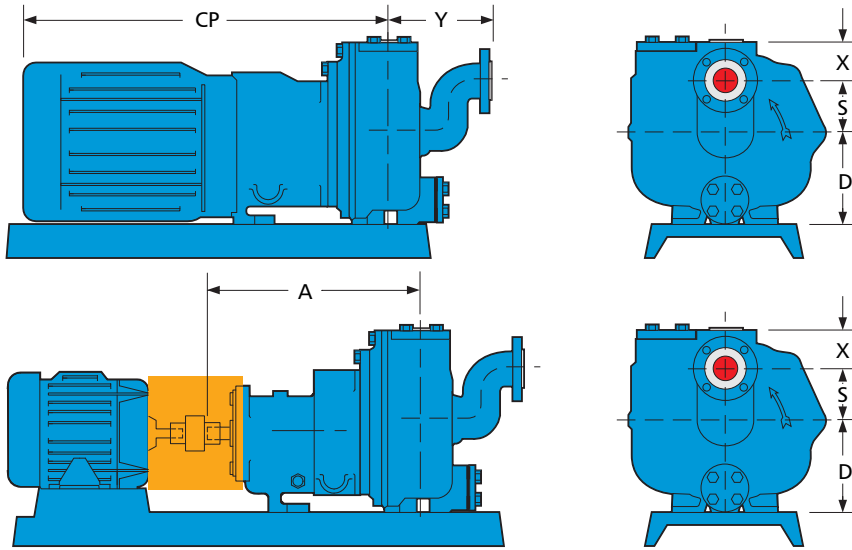

SP 3298 Close-Coupled Design

SP 3298 Frame-Mounted Design

Bare Pump Dimensions							
Size	A	D	S	X	Y	Close-Coupled	Frame-Mounted
1 X 1 1/2-6	15.5 (393.7)	11.5 (292.1)	4.0 (101.6)	7.25 (184.2)	7.5 (190.5)	160 lbs. (72.7 kg.)	175 lbs. (79.5 kg.)
2 X 3-6	15.5 (393.7)	13.5 (342.9)	6.0 (152.4)	10.75 (273.1)	12.12 (307.8)	198 lbs. (90 kg.)	213 lbs. (96.8 kg.)

Close-Coupled	
Motor Frame	CP (Approx.)
143TC	21 (533)
145TC	20 (508)
182TC/184TC	24 (610)
213TC/215TC	27.63 (702)
254TC/256TC	32.12 (816)
284TSC/286TSC	32.12 (816)

# Hydraulic Coverage Model SP 3298

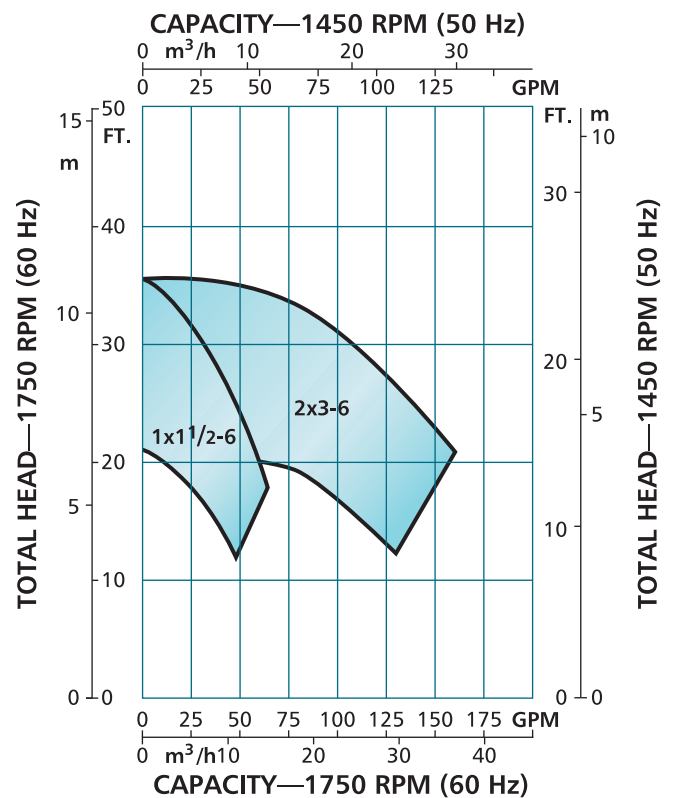
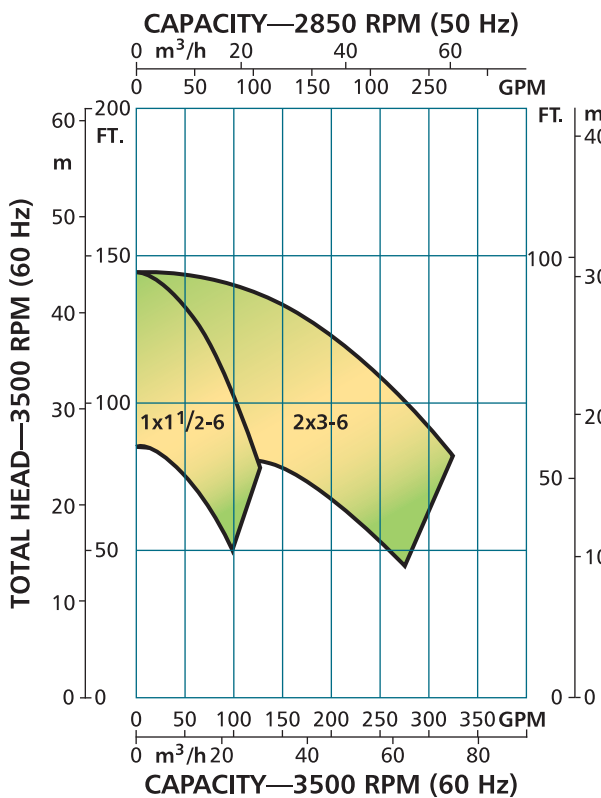

# Model V 3298 In-Line Design for Cost Savings

### In-Line Design for Cost Savings

In-line pumps have become increasingly popular due to minimal floor space required and reduced installation costs. Installation is simple since the unit is mounted directly in the line, like a valve. Field alignment is not required and the unit is not subject to misalignment due to pipe strain or temperature changes.

### Additional Dry-Run Protection

With the vertical design, the front thrust bearing will always be submerged in liquid. This unique feature adds an extra measure of dry run protection.

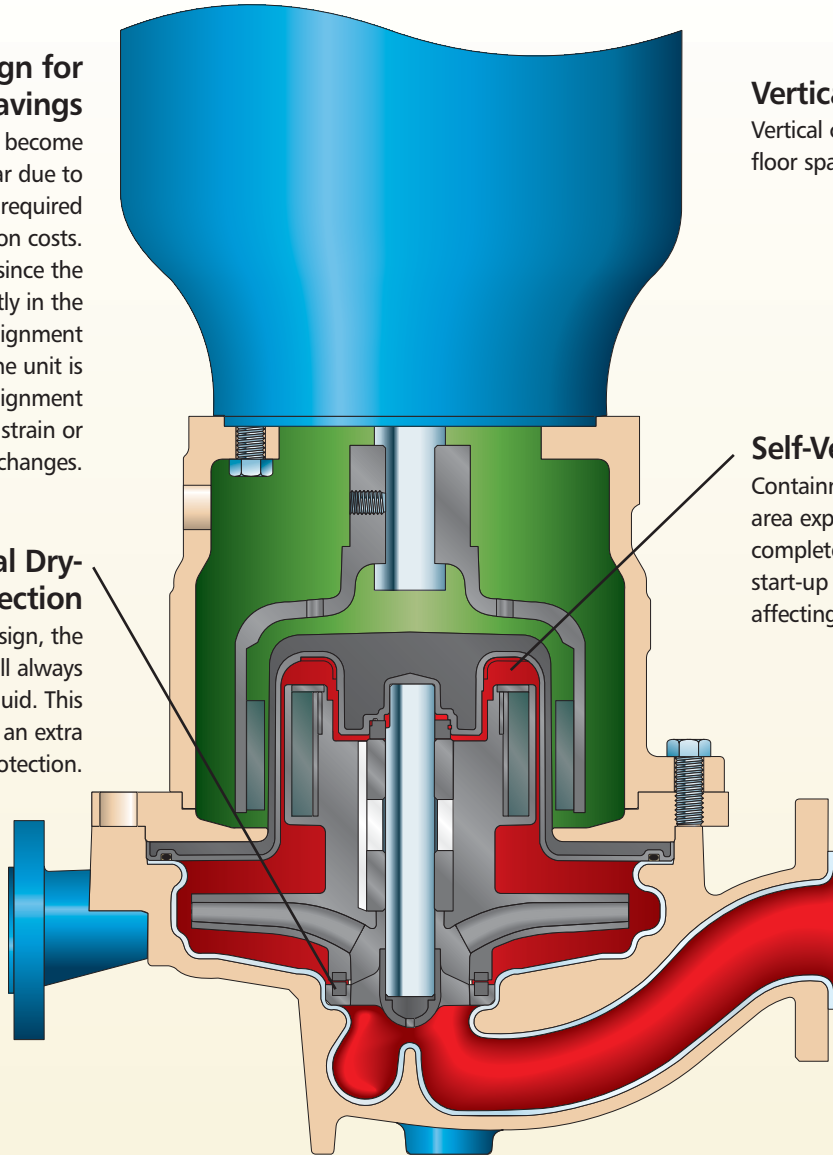

### Vertical Configuration

Vertical casing frees up additional floor space required for pump.

### Self-Venting Design

Containment shell and magnet area expel all trapped air/gases completely and efficiently during start-up without adversely affecting the shaft and bearings.



### Drain Connection

Allows complete draining of fluid from pump for system maintenance. Blind flange and gasket ensure leak-free seal for safety.

### Casing Support

Optional casing supports provide rigid pump support when a pipe hung pump is not an option.



### Parts Interchangeability

All components fully interchangeable with 3298 and SP3298, except the casing. Reduces spare parts inventory requirements.



# Dimensions Model V 3298

All dimensions in inches and (mm). Not to be used for construction.

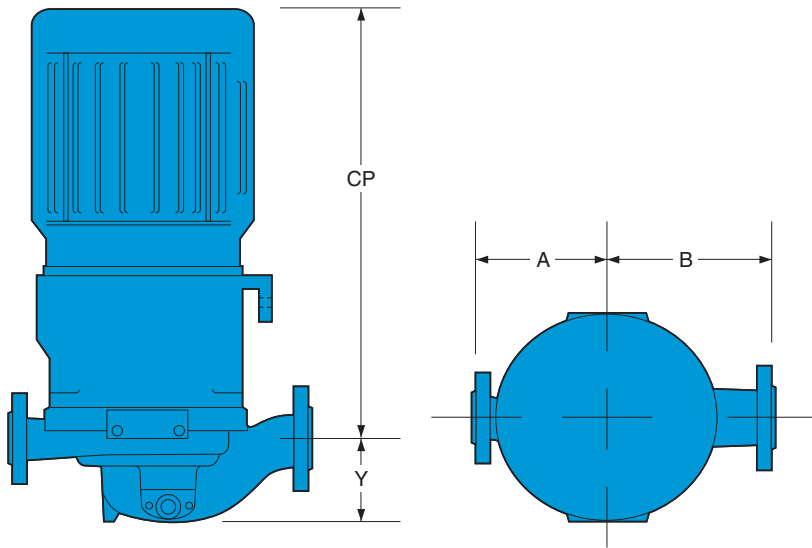

Group	Size	Y	A	B	Weight
S	1 1/2 X 2-6	4.50 (114.3)	8.12 (206.2)	6.62 (168.1)	79 lbs (35.9 kg)
	1 1/2 X 2-8	5.06 (128.5)	8.88 (225.6)	7.88 (200.2)	91 lbs (41.4 kg)
	2 X 3-6	4.88 (124)	9.39 (238.5)	7.39 (187.7)	100 lbs (45.5 kg)
M	1 1/2 X 2-10	5.12 (130)	9.69 (246.1)	9.19 (233.4)	188 lbs (85.5 kg)

Close-Coupled		
Motor Frame	Group	CP (Approx.)
143TC	S	19.00 (463)
145TC	S	18.00 (457)
182TC/184TC	S	22.12 (562)
	M	25.03 (636)
213TC/215TC	S	25.62 (651)
	M	28.53 (725)
254TC/256TC	S	30.12 (765)
	M	33.03 (839)
284TSC-286TSC	M	36.78 (934)
324TSC-326TSC	M	40.00 (1016)

# Hydraulic Coverage Model V 3298

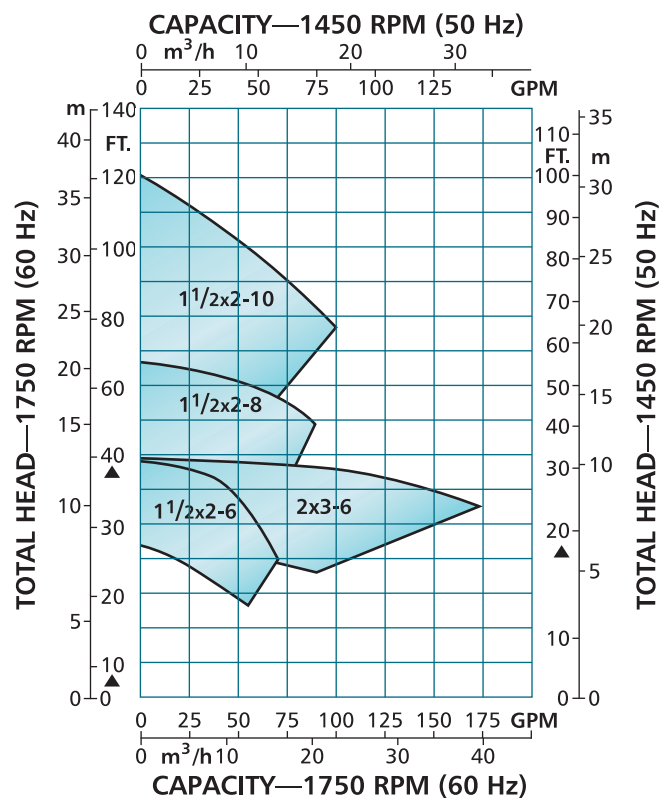
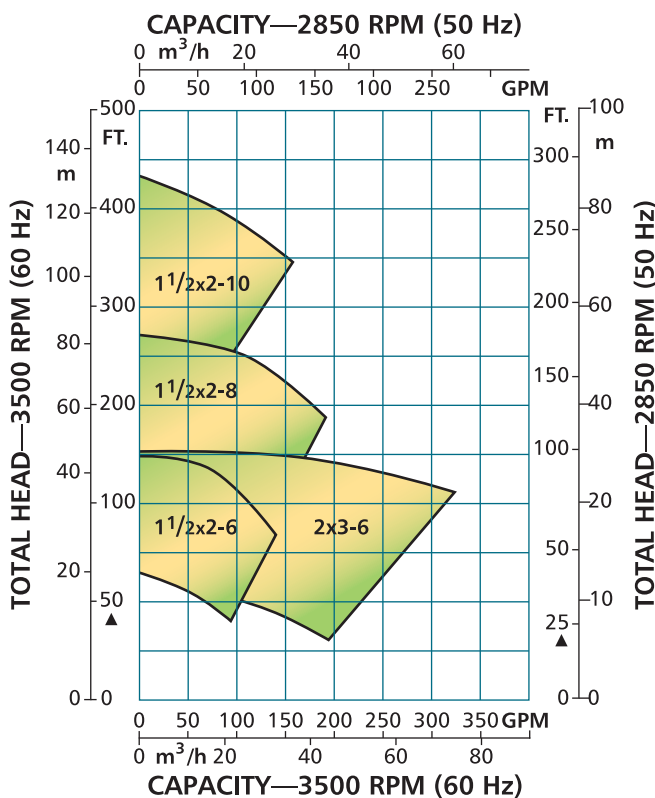

## Leadership in Sealless Pump Technology

### Model 3299 Heavy-Duty Lined Chemical Pump

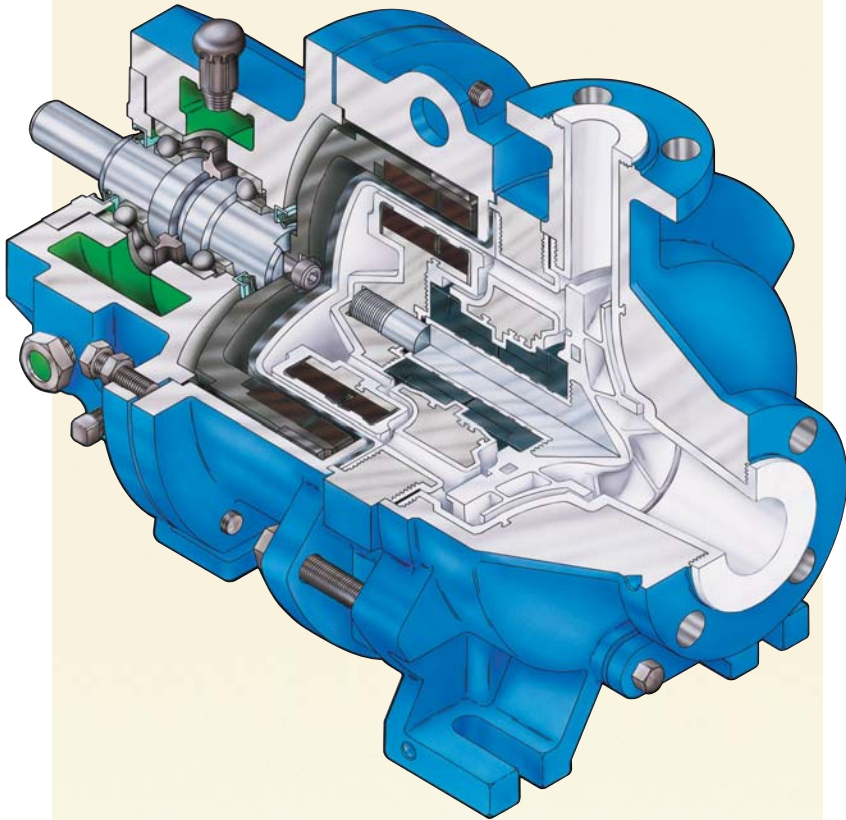

#### Dry Run Capability



#### Standard Dryguard™ Silicon Carbide Bearings

Provide the corrosion resistance and durability of silicon carbide with short term dry run capability without the catastrophic failure modes of standard silicon carbide in a dry run situation.

#### Solids Handling

Standard large internal clearances allow the passage of solids up to 0.06 inches with a maximum concentration of 2%. With the optional clean external injection flush, the 3299 can handle solids up to 0.080 inches with a concentration near 10%.



#### PFA Construction for Universal Corrosion Resistance to 360°F (182°C)

Virgin Teflon® (PFA) is virtually inert to all chemicals and has good abrasion resistance. PFA lined casing, bearing carrier, containment shell, and one-piece impeller/shaft assembly provide superior corrosion resistance and long life, unequalled by alloy pumps.

#### Designed for Safe Operation

##### Dual Containment Shell

PTFE lining with carbon fiber reinforced plastic (CFRP) shell. Non-metallic construction provides efficiencies the same or better than sealed ANSI pumps; 30% higher efficiencies than metal sealless pumps.

Non-metallic construction eliminates magnet losses and heat generation. CFRP shell provides rigid support for the liner and acts as a secondary method of containment should the primary liner fail.



#### Integral Shaft and Impeller

Large 316 stainless steel core improves impeller mechanical strength. Integral PFA lined 316 stainless shaft and impeller optimizes corrosion resistance, strength and durability of the stainless steel shaft.

# Hydraulic Coverage Model 3299

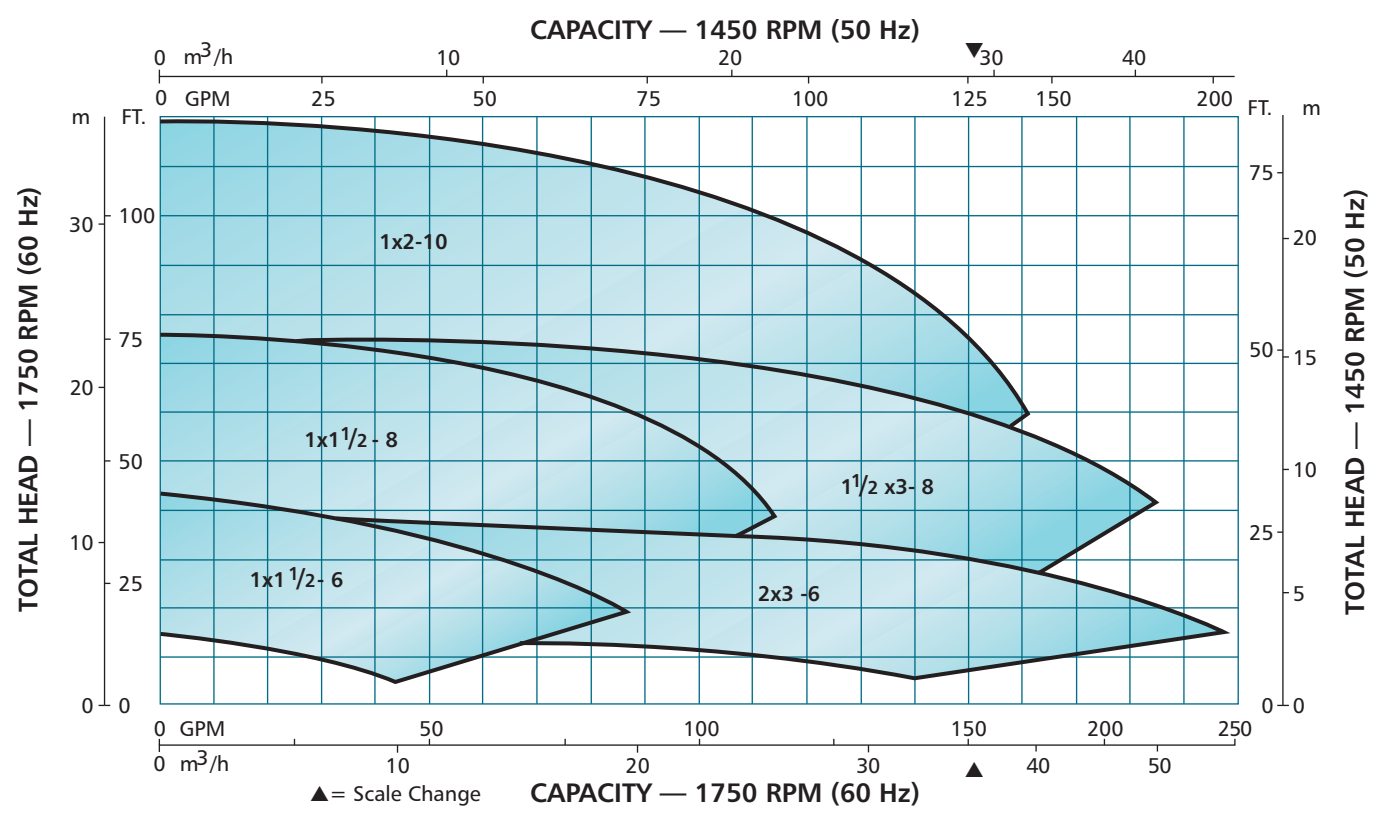
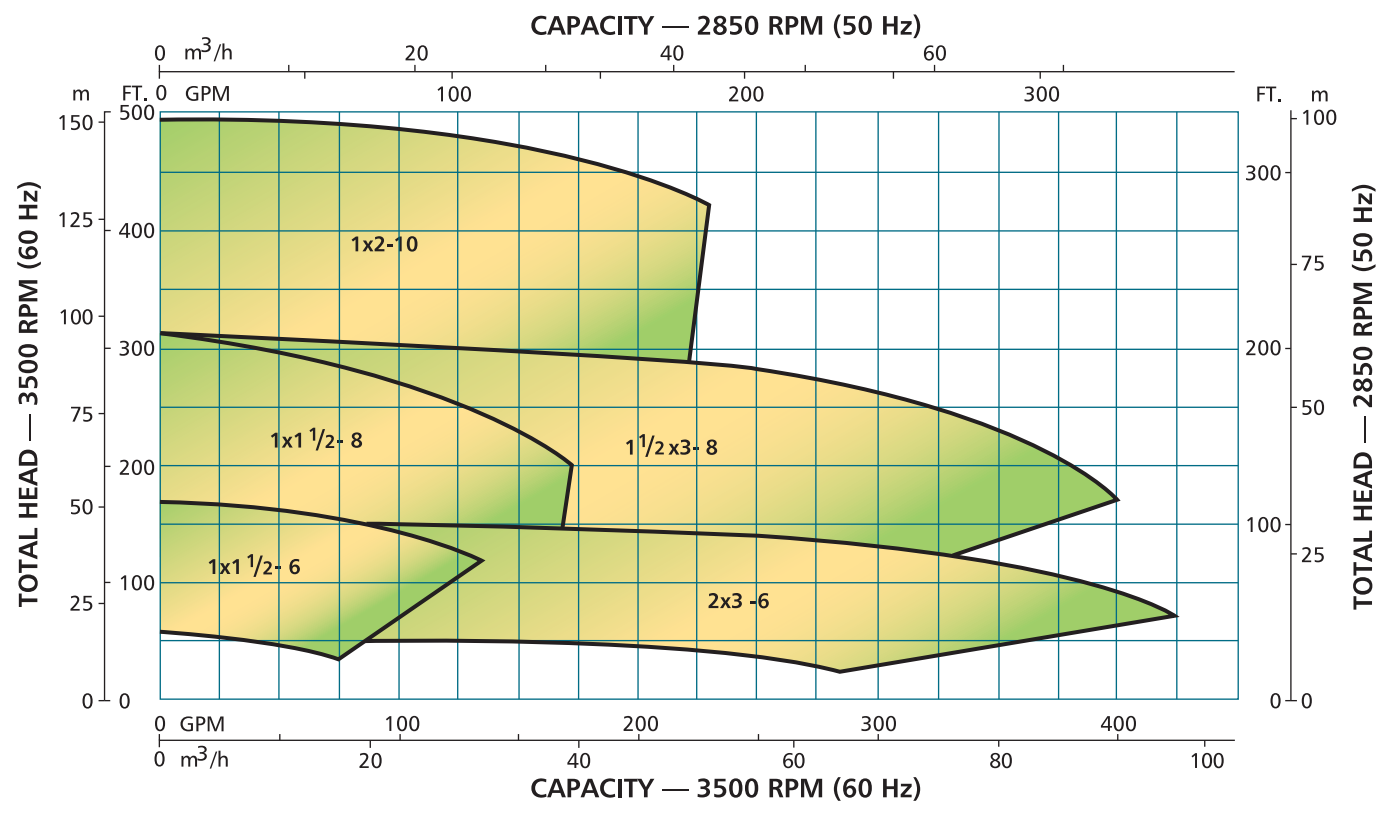

# Leadership in Sealless Pump Technology

## Model 3296 EZMAG

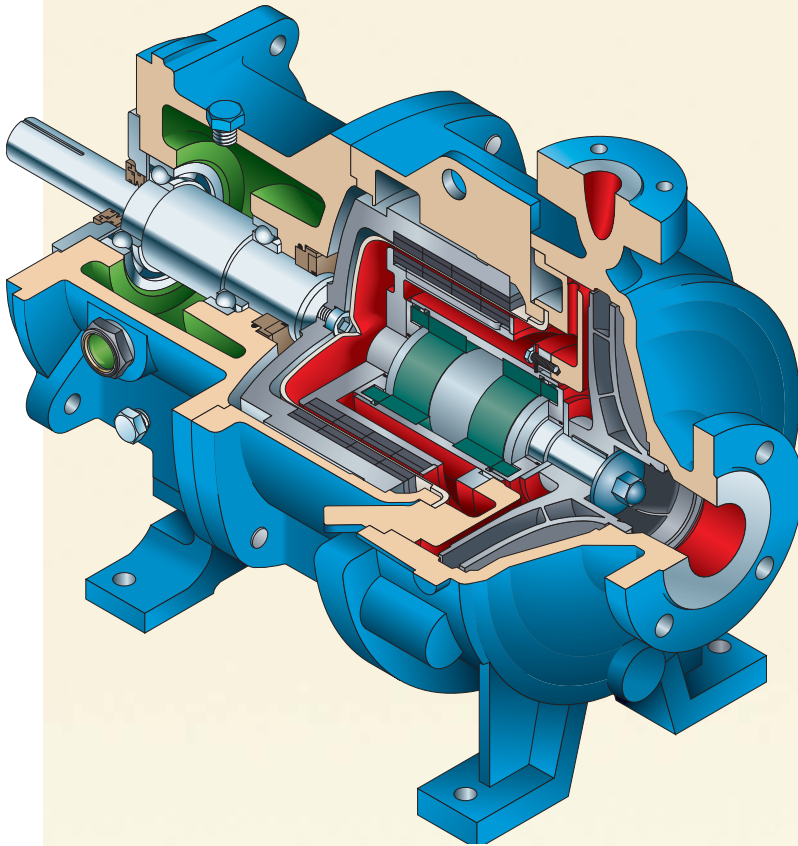

### Bearing Cartridge

Individual bearings are contained in a single cartridge assembly.

- ◆ Bearings are made of highly abrasion and corrosion resistant silicon carbide. Dryguard™ bearings are available for protection against occasional dry run conditions.
- ◆ In the event of bearing failure, the cartridge design contains the bearings and prevents further damage to pump internals.
- ◆ Installation and replacement of bearings is simple. Only one component to install.



### Maintenance Made Simple

The 3296 EZMAG was designed with the end user in mind. Fewer parts make planned maintenance faster and easier than other sealless and sealed process pumps. The S group is also available in a close coupled configuration, further eliminating the need for time-consuming pump and motor alignment.

### Containment Shell

The containment shell is the most important component isolating the pumpage from the atmosphere.

- ◆ The containment shell is a deep-drawn single piece design made from Hastelloy C for reliable corrosion resistance.
- ◆ The vortex-breaking bead at the bottom of the can prevents erosion.
- ◆ Burst pressure is greater than 2,175 psi.



### Dryguard™ Bearings

The heat generation from dry run conditions is the number one mode of failure for sealless pumps. Dryguard™ is a diamond-like carbon that reduces the coefficient of friction by over 70% enabling short periods of safe operation under dry run conditions. Dryguard™ is up to 2X harder than silicon carbide, ensuring its benefits cannot be compromised in even the harshest conditions.



### High Temperature Applications

The High Temperature option is perfect for applications between 350°F and 535°F. This option includes Samarium Cobalt

magnets and a special High Temperature bearing cartridge designed to handle the additional rate of thermal expansion.



## Hydraulic Coverage 3600/2900 RPM

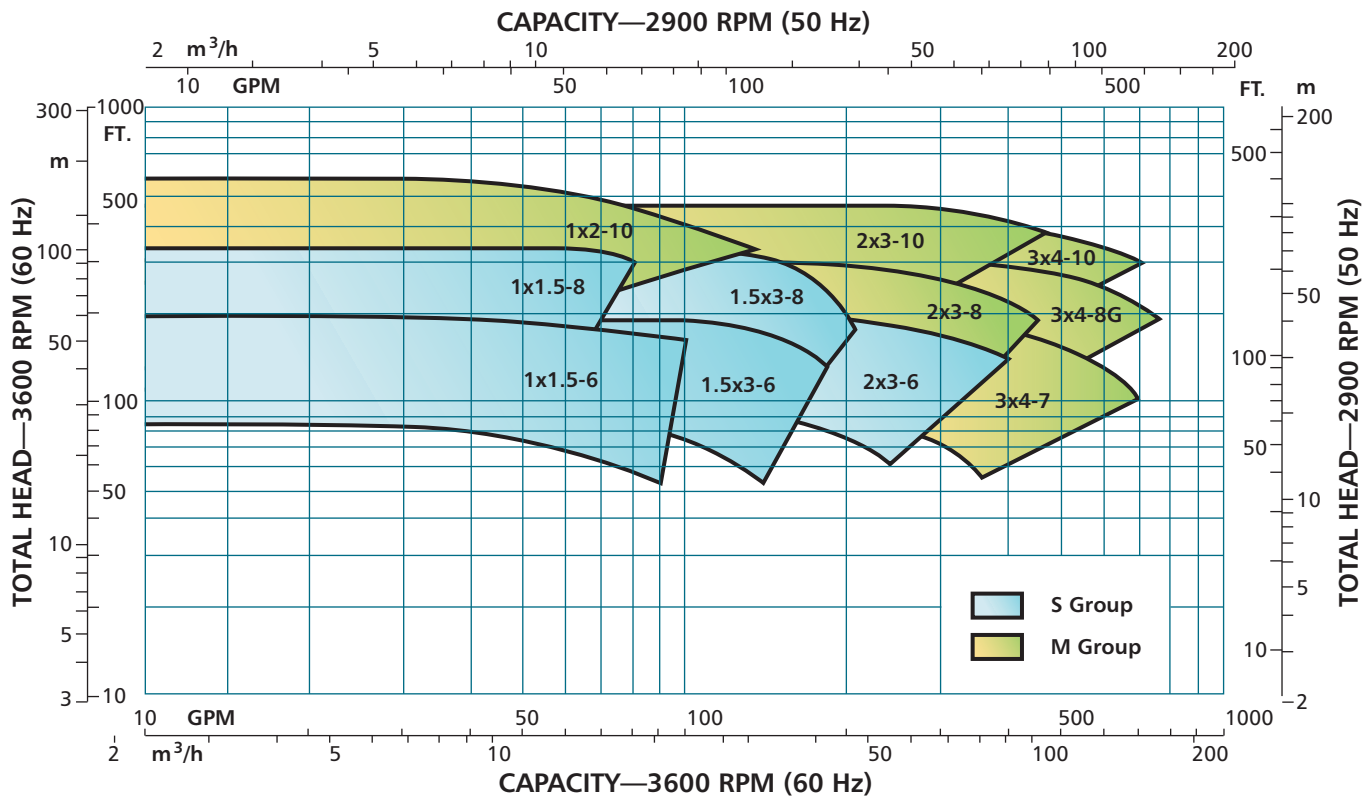

## Hydraulic Coverage 1800/1450 RPM

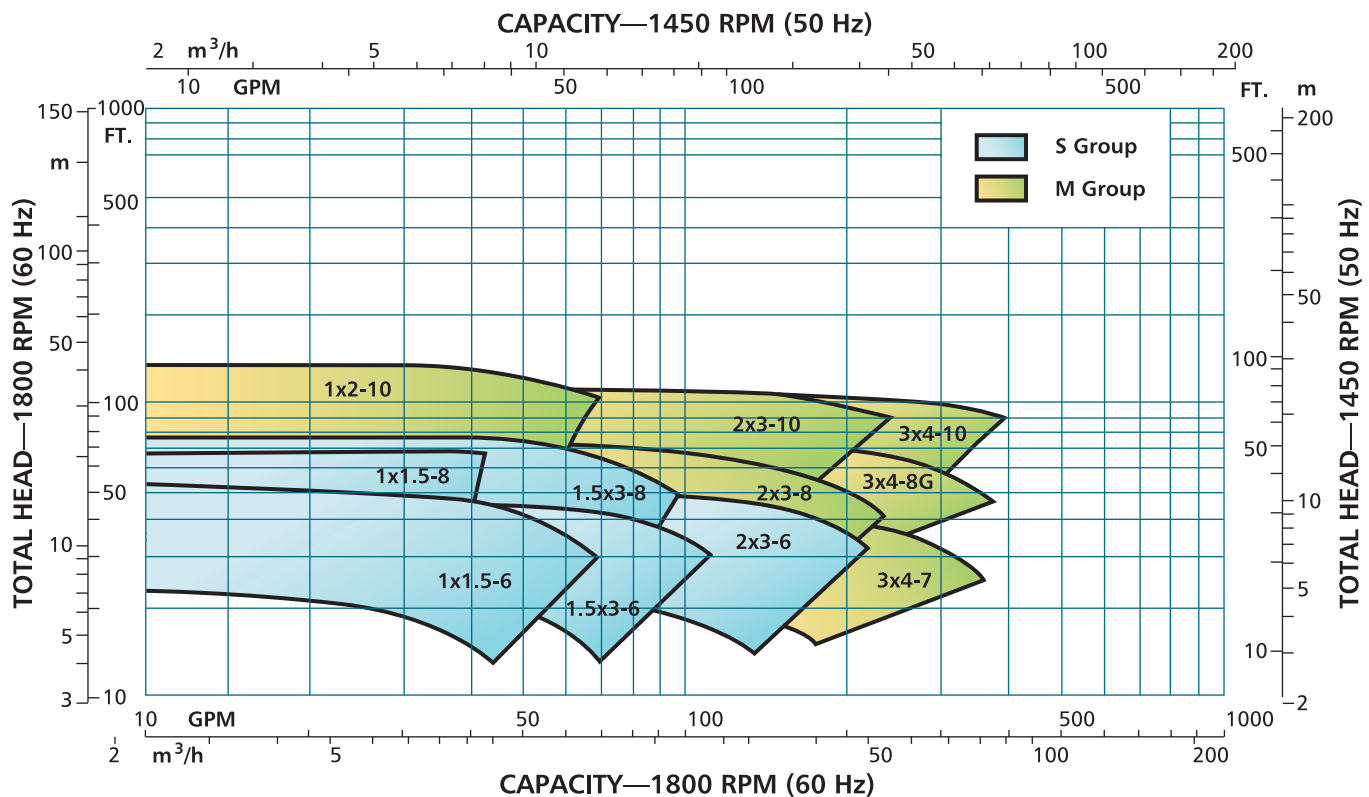





# Sealless Selection Chart

Model	Installation Considerations				Materials of Construction				Temperature Limits (F)					Pumpage		
	ANSI Dim	ISO Dim	Sumps	Limited Floor Space	PFA TEFLON®	ETFE TEFZEL®	Stainless Steel	High Alloys	-40 F	-20 F	250 F	360 F	535 F	Corrosive	Solids	Hazardous
3298																
V3298																
SP3298																
3299																
3296 EZ-MAG																
ICM																

