



ITT

Goulds Pumps

Goulds CW/CWX

Pumps for Abrasive Slurries



Engineered for life

motralec

4 rue Lavoisier . ZA Lavoisier . 95223 HERBLAY CEDEX
Tel. : 01.39.97.65.10 / Fax. : 01.39.97.68.48
Demande de prix / e-mail : service-commercial@motralec.com
www.motralec.com



Model CW/CWX

Single stage, enclosed impeller, back pull-out process pump for abrasive slurries.

The Model CW/CWX horizontal pumps are designed to efficiently pump liquids with abrasive solids in suspension. With wear parts made of HC600 chrome iron, the CW/CWX pumps give long life and superior performance in all types of slurry applications. The Model CWX with Shearpeller has air and solids handling capabilities significantly superior to conventional designs.

Design Features

Standardized Design — Only three power ends for maximum inter-changeability of parts and reduced spare parts inventory.

Back Pull-Out Design — Single craft maintenance.

Shearpeller Option (Model CWX) — Enables pumping of stringy solids and entrained air.

Rugged Casing — Casings are made of abrasion resistant HC600 with extra thick metal sections for maximum operating life.

Enclosed Impeller — For long life and trouble-free service.

Renewable Front and Rear Wear Plates — To protect the casing.

Long-Wearing Shaft Sleeve — XH-800 hook-type shaft sleeve protects the carbon steel shaft for the full-length of the stuff box, and extends through the packing gland.

Heavy-Duty Shaft — Shaft is heavy-duty SAE 1045 steel, designed with minimum over-hang to reduce deflection.

Bearing Protection — Bearings are mounted in machined fits in each end of the frame liner.

Dynamic Seal Option — Eliminates packing and associated maintenance.

Services

- Coal Preparation
- Kaolin
- Sugar Mills
- Steel Mills
- Cement Plants
- Aggregates
- Power Generation
- Coal Slurry
- Clay Slip
- Raw Juice
- Scale Pit
- Cyclone Feed
- Sand and Gravel
- Ash Handling Systems

Hydraulic Coverage

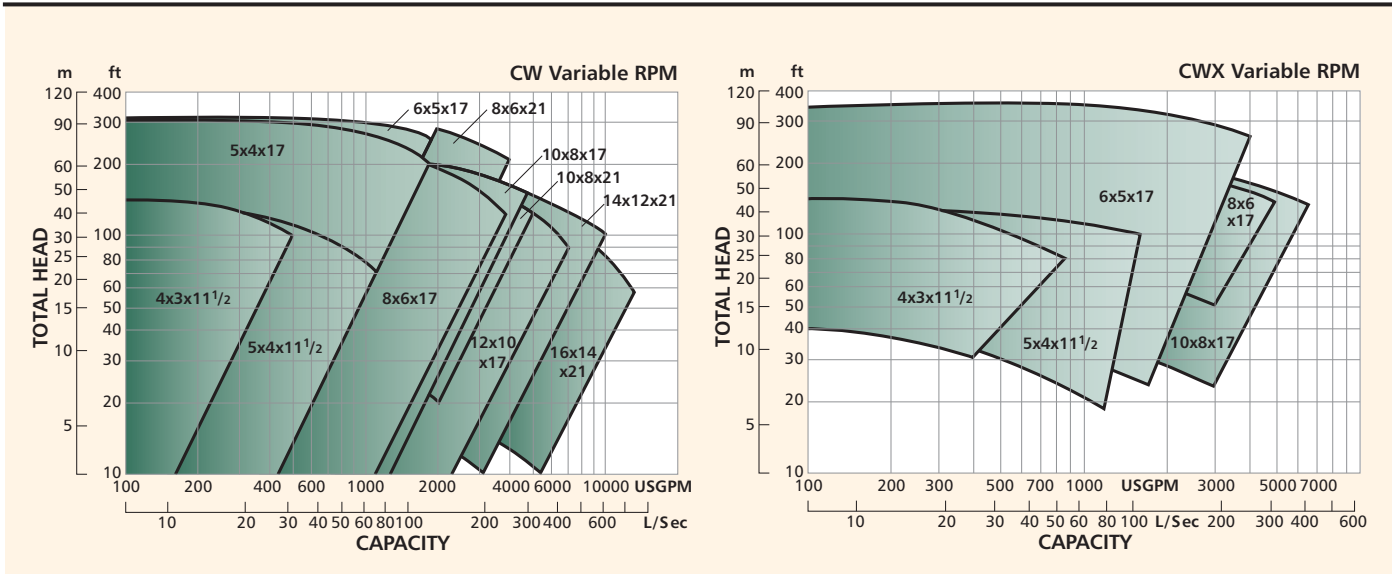

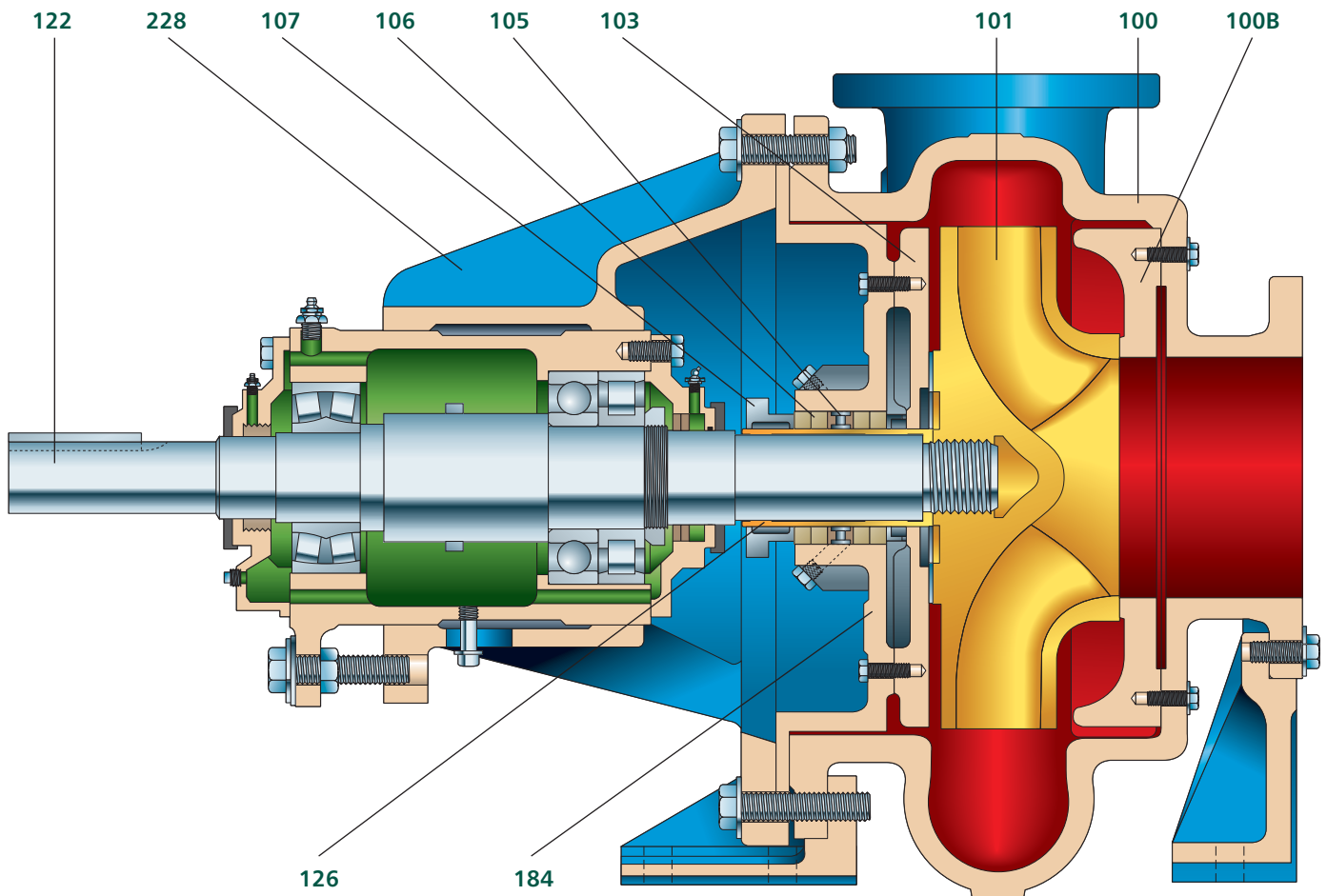

Parts List and Materials of Construction

Part Number	Part Name	Material
100	Casing	HC600
100B	Suction Liner	HC600
101	Impeller	HC600
103	Rear Liner	HC600
105	Lantern Ring	Teflon®
106	Packing	Graphite Synthetic
107	Gland	Cast Iron
122	Shaft	1045 Steel
126	Shaft Sleeve	XH800
184	Stuffing Box Cover	Cast Iron
228	Frame	Cast Iron

Description	Specification
HC600	ASTM A532, Class III Type A Hardened
Cast Iron	ASTM A48
XH800	Hard-Coated, Stainless Steel
1045 Steel	ASTM A576-90b

CWX Non-Clogging Pumps

CWX Pumps embody an innovative, yet time — proven concept in pump design. The unique, patented Shearpeller successfully handles large, stringy or fibrous solids in suspension, entrained air in water, viscous materials plus many other hard-to-pump slurries.

The Shearpeller's radial vanes narrow as they approach the eye to allow large or stringy solids to enter. This way, almost anything that enters the impeller can be pumped. The vanes widen toward the OD of the impeller to provide a positive pumping action and higher heads than fully recessed impeller pumps.

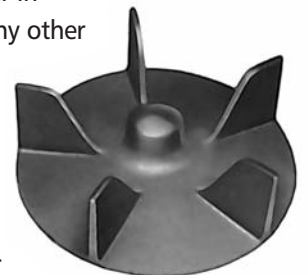

TEFLON® is a registered trademark for fluoropolymer resins, films and fibers made by DuPont.

Dimensions

All dimensions in inches and (mm). Not to be used for construction.

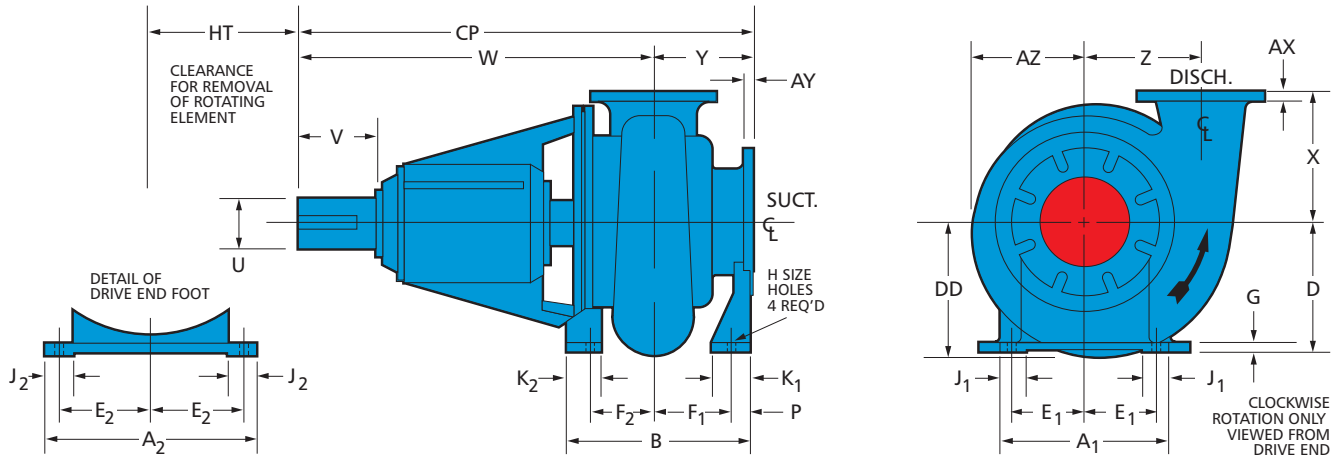

DIMENSIONS

Pump Size	Suct.	Disch.	A ₁	A ₂	B	D	E ₁	E ₂	F ₁	F ₂	G	H	J ₁	J ₂	K ₁	K ₂	P
4x3x11-1/2	4.00 (102)	3.00 (76)	15.00 (381)	15.00 (381)	16.25 (413)	10.50 (267)	6.63 (168)	6.63 (168)	5.38 (137)	7.38 (187)	1.00 (25)	1.00 (25)	2.50 (64)	2.50 (64)	3.50 (89)	5.50 (140)	2.00 (51)
5x4x11-1/2	5.00 (127)	4.00 (102)	15.00 (381)	15.00 (381)	16.25 (413)	10.50 (267)	6.63 (168)	6.63 (168)	5.38 (137)	7.38 (187)	1.00 (25)	1.00 (25)	2.50 (64)	2.50 (64)	3.50 (89)	5.50 (140)	2.00 (51)
5x4x17	5.00 (127)	4.00 (102)	19.00 (483)	24.00 (610)	17.69 (449)	13.63 (346)	8.50 (216)	11.00 (279)	6.63 (168)	6.31 (160)	1.25 (32)	1.00 (25)	3.00 (76)	3.00 (76)	4.25 (108)	5.00 (127)	2.25 (57)
6x5x17	6.00 (152)	5.00 (127)	19.00 (483)	24.00 (610)	19.31 (491)	13.63 (346)	8.50 (216)	11.00 (279)	7.56 (192)	7.00 (178)	1.25 (32)	1.00 (25)	3.00 (76)	3.00 (76)	4.25 (108)	5.00 (127)	2.25 (57)
8x6x17	8.00 (203)	6.00 (152)	19.00 (483)	24.00 (610)	19.75 (502)	13.63 (346)	8.50 (216)	11.00 (279)	7.75 (197)	7.25 (184)	1.25 (32)	1.00 (25)	3.00 (76)	3.00 (76)	4.25 (108)	5.00 (127)	2.25 (57)
10x8x17	10.00 (254)	8.00 (203)	19.00 (483)	24.00 (610)	20.56 (522)	13.63 (346)	8.50 (216)	11.00 (279)	8.13 (206)	7.69 (195)	1.25 (32)	1.00 (25)	3.00 (76)	3.00 (76)	4.25 (108)	5.00 (127)	2.25 (57)
12x10x17	12.00 (305)	10.00 (254)	19.00 (483)	24.00 (610)	23.81 (605)	13.63 (346)	8.50 (216)	11.00 (279)	10.81 (275)	8.56 (217)	1.25 (32)	1.00 (25)	3.00 (76)	3.00 (76)	3.88 (98)	5.00 (127)	1.94 (49)
8x6x21	8.00 (203)	6.00 (152)	27.50 (699)	31.50 (800)	24.25 (617)	18.63 (473)	12.00 (305)	14.00 (356)	7.75 (197)	11.50 (292)	1.50 (38)	1.50 (38)	4.50 (114)	4.50 (114)	4.50 (114)	5.00 (127)	2.25 (57)
10x8x21	10.00 (254)	8.00 (203)	27.50 (699)	31.50 (800)	25.75 (654)	18.63 (473)	12.00 (305)	14.00 (356)	9.69 (246)	10.81 (275)	1.50 (38)	1.50 (38)	4.50 (114)	4.50 (114)	5.00 (127)	5.00 (127)	2.50 (64)
14x12x21	14.00 (356)	12.00 (305)	27.50 (699)	31.50 (800)	28.25 (718)	18.63 (473)	12.00 (305)	14.00 (356)	12.50 (318)	10.75 (273)	1.50 (38)	1.50 (38)	4.50 (114)	4.50 (114)	4.50 (114)	5.00 (127)	2.25 (57)
16x14x21	16.00 (406)	14.00 (356)	27.50 (699)	31.50 (800)	30.00 (762)	18.63 (473)	12.00 (305)	14.00 (356)	14.00 (356)	10.75 (273)	1.50 (38)	1.50 (38)	4.50 (114)	4.50 (114)	5.00 (127)	5.00 (127)	2.50 (64)

Pump Size	Keyway			V	W	X	Y	Z	AX	AY	AZ	CP	DD	HT	
	U	Depth	Width Length												
4x3x11-1/2	1.625 (41.2)	0.19 (5)	0.38 (10)	3.75 (95)	5.00 (127)	26.50 (673)	10.25 (260)	7.50 (191)	8.13 (206)	0.75 (19)	1.00 (25)	8.50 (216)	34.00 (264)	9.06 (230)	7.50 (191)
5x4x11-1/2	1.625 (41.2)	0.19 (5)	0.38 (10)	3.75 (95)	5.00 (127)	26.50 (673)	10.25 (260)	7.50 (191)	8.63 (219)	1.00 (25)	1.00 (25)	9.13 (232)	34.00 (264)	9.88 (251)	7.50 (191)
5x4x17	2.375 (60.3)	0.31 (8)	0.63 (16)	4.50 (114)	7.00 (178)	32.50 (826)	15.00 (381)	9.00 (229)	12.25 (311)	1.00 (25)	1.13 (29)	13.25 (337)	41.50 (1054)	14.50 (368)	11.50 (292)
6x5x17	2.375 (60.3)	0.31 (8)	0.63 (16)	4.50 (114)	7.00 (178)	33.06 (840)	13.38 (340)	10.00 (254)	11.50 (292)	1.00 (25)	1.13 (29)	12.06 (306)	43.06 (1094)	13.00 (330)	11.50 (292)
8x6x17	2.375 (60.3)	0.31 (8)	0.63 (16)	4.50 (114)	7.00 (178)	33.19 (843)	13.38 (340)	10.25 (260)	12.25 (311)	1.13 (29)	1.13 (29)	12.06 (306)	43.44 (1103)	14.13 (359)	11.50 (292)
10x8x17	2.375 (60.3)	0.31 (8)	0.63 (16)	4.50 (114)	7.00 (178)	33.63 (854)	14.00 (356)	10.75 (273)	13.00 (330)	1.13 (29)	1.25 (32)	13.75 (349)	44.38 (1127)	15.50 (394)	11.50 (292)
12x10x17	2.375 (60.3)	0.31 (8)	0.63 (16)	4.50 (114)	7.00 (178)	34.50 (876)	16.00 (406)	13.00 (330)	14.38 (365)	1.19 (30)	1.25 (32)	15.25 (387)	47.50 (1207)	17.88 (454)	11.50 (292)
8x6x21	3.500 (89)	0.44 (11)	0.88 (22)	9.00 (229)	11.00 (279)	54.50 (1384)	16.00 (406)	10.25 (260)	14.75 (375)	1.13 (29)	1.13 (29)	15.38 (391)	64.75 (1645)	16.63 (422)	17.50 (445)
10x8x21	3.500 (89)	0.44 (11)	0.88 (22)	9.00 (229)	11.00 (279)	54.06 (1373)	21.00 (533)	12.44 (316)	15.38 (391)	1.13 (29)	1.25 (32)	16.38 (416)	66.50 (1689)	17.75 (451)	17.50 (445)
14x12x21	3.500 (89)	0.44 (11)	0.88 (22)	9.00 (229)	11.00 (279)	53.75 (1365)	21.00 (533)	15.00 (381)	17.38 (441)	1.25 (32)	1.44 (37)	18.50 (470)	68.75 (1746)	22.13 (562)	17.50 (445)
16x14x21	3.500 (89)	0.44 (11)	0.88 (22)	9.00 (229)	11.00 (279)	53.75 (1365)	21.00 (533)	16.75 (425)	18.63 (473)	1.38 (35)	1.44 (37)	20.13 (511)	70.50 (1791)	24.88 (632)	17.50 (445)

Member of



motralec

4 rue Lavoisier . ZA Lavoisier . 95223 HERBLAY CEDEX

Tel. : 01.39.97.65.10 / Fax. : 01.39.97.68.48

Demande de prix / e-mail : service-commercial@motralec.com

www.motralec.com