

Goulds HT 3196 *i-FRAME*TM

High-Temperature Process Pumps

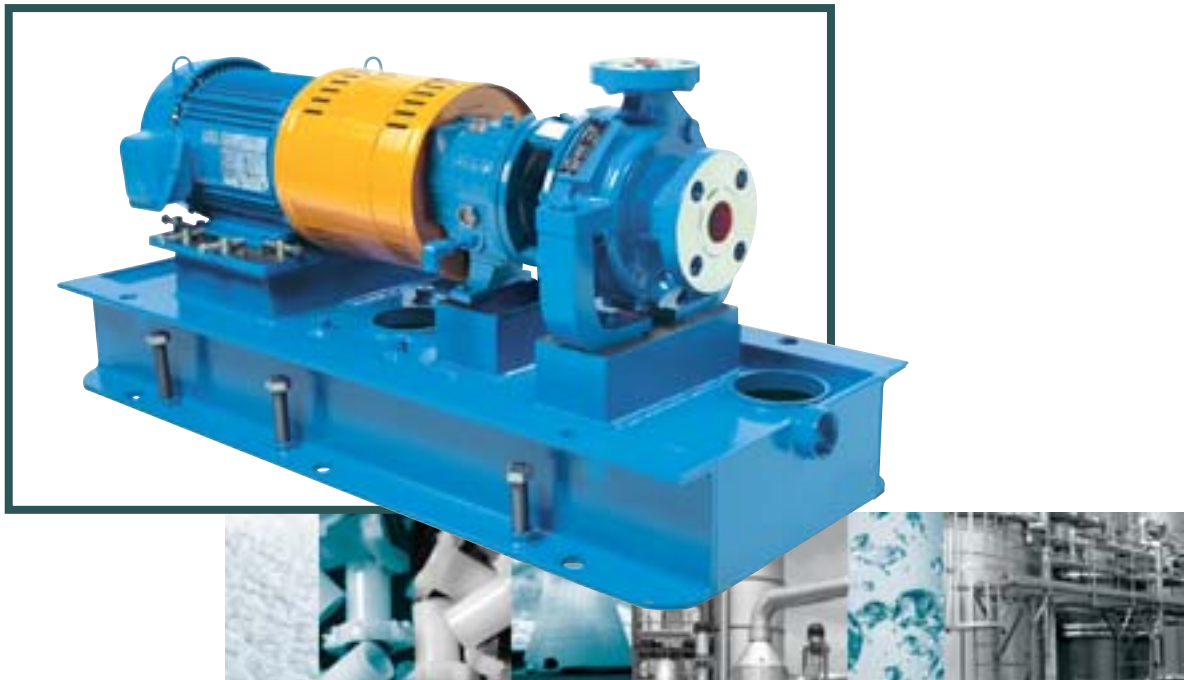

Model HT 3196 *STi*
5 pump sizes



Model HT 3196 *LF*
3 low flow pump sizes



Model HT 3196 *MTi/LTi*
15 pump sizes



Model HT 3196 *XLTi*
5 pump sizes

Global ANSI Process Pump Leader

Introducing the newest member to the world's most popular ANSI pump family... HT 3196

Goulds HT 3196 Severe Duty Process Pump

- ◆ Capacities to 4,500 gpm (1,023 m³/hr.)
- ◆ Heads to 925 ft (282m)
- ◆ Temperatures up to 700°F (372°C)
- ◆ Pressures up to 450 Psig (3,102 kPa)

◆ Material of Construction

- Carbon Steel
- Duplex SS (CD4MCu)
- Ductile Iron
- Alloy 20
- 316SS Stainless Steel
- Hastelloy C

◆ Performance Features for Extreme Temperatures Extended Pump Life

- Centerline mounted design allows bi-directional thermal expansion which maintains shaft alignment for improved seal and bearing life
- Comprehensive range of seal chambers including patented TaperBore Plus™ and Big Bore™ designs maintain cool and clean seal environments critical for extended seal life
- *i-FRAME*™ Power ends featuring heavy duty, large capacity oil sump with finned tube oil cooler maintains cooler oil temperatures for extended bearing life

◆ Reduced Maintenance Cost

- Interchangeability with 3196 reduces MRO inventories (All parts except casing are the same as 3196)
- Standard ANSI dimensions simplify installation and support pump retrofits of standard foot mounted design
- Back-pull out design facilitates safe and simple maintenance activities

◆ Markets

- Chemical/Petrochemical
- Food & Beverage
- Pharmaceutical
- Rubber & Plastic Manufacturing
- Pulp & Paper
- Power/Utility

◆ Applications

- Hot Water
- Pilot Plants
- Thermal Oils/
Heat Transfer Fluids
- Electronic Heating and Cooling
- Die/Mold
- Reactor Heating
- Pre-heating Systems
- Urea

Optimized Performance At High Operating Temps Up To 700° F (372° C)



The HT 3196 is furnished with the following standard features:

- Centerline-mounted casing
- ANSI Class 300 RF flanges
- Graphite casing gasket
- Graphite impeller O-ring
- High temperature bolting
- Stainless steel shaft
- Finned tube oil cooler

Thermal expansion due to high temperature process fluids handling is optimally controlled with centerline mounted casings. Centerline mounting minimizes shaft misalignment since the casing can expand bi-directionally. This same feature minimizes pipe strain as the casing is permitted to grow in two directions theoretically negating strain on suction piping.

ANSI Class 300 raised face flanges provide a positive sealing surface to prevent tough-to-seal liquids like hot hydrocarbons and heat transfer liquids from escaping into your regulated environment.

The HT 3196 delivers...

ANSI and PIP Compliance

ANSI B73.1M and PIP RESP 73H-97 dimensional compliance and rugged construction for proven performance. Heavy duty centerline mounted casing stabilizes shaft alignment and minimizes piping strain while compensating for thermal expansion when pumping fluids up to process temperatures of 700° F (372° C).

Sealing Flexibility

The HT 3196 offers the industry's greatest cartridge sealing flexibility with optimum seal environments including Standard Bore, Big Bore and Goulds patented Taper Bore Plus™ with VPE rings. Jacketed seal chambers are available for controlling the temperature of the mechanical seal's environment and maximizing seal life. High performance, high temperature cartridge mechanical seals are available from nearly all manufacturers for optimum sealing reliability.

High Alloy Availability

Liquid ends are available in Carbon Steel, Ductile Iron, 316SS, CD4MCu, Alloy 20 and Hastelloy C constructions to provide materials flexibility for pumping heat transfer fluids, hot oils and moderate to highly aggressive hot chemicals.

Interchangeability

Completely interchangeable with the Goulds model 3196, the world's most installed ANSI process pump. All internal components are common between models except for the casing. The X-series power end provides common inventory for models 3196, CV 3196, HT 3196, LF 3196, NM 3196, 3198 and 3796.

Lead-times

Maximized parts interchangeability with the Goulds model 3196 results in optimized lead-times with our

ANSI product line for fast response to customer needs.

Five-Year Standard Warranty

i-FRAME™ pumps feature a 5-year warranty that acknowledges superior performance, optimum run time, and extended pump life.



High Temperature Pumping Applications

High Temperature Oils and Heat Transfer Fluids

The use of synthetic heat transfer liquids continues to expand as these liquids offer chemical stability and efficient heat transfer properties. In addition, the use of these liquids allows system pressures to be reduced for added safety and lower design costs. Hot natural oils and synthetic oils are used in heat transfer, food processing, oil refining and petrochemical mining applications. Some applications for hot oils and heat transfer fluids include computer and power supply, energy storage, transformer cooling, recirculating chillers, train traction rectifiers, re-flow soldering, industrial processing, pharmaceutical processing and semiconductor processing.



High Temperature Chemical Processing

The Goulds Model HT 3196 features superior chemical corrosion resistance through optimal manufacturability of high alloy wetted pump components. Offered in Carbon Steel, Ductile Iron, 316ss, CD4MCu, Alloy 20 and Hastelloy C, the HT 3196 provides a well-rounded selection of materials to maximize pump life

when pumping hot, aggressive solvents, acids and chlorides. High temperature fluid applications include asphalt, tars, Naphtha, Naphthalene, aromatics, hydrocarbons, urethanes, epoxies, paints, zinc compounds, magnesium compounds, adhesives, plastisizers, polyols, polymers, monomers, resins, oxide slurries, pigments, dyes, inks and many more.

Bonus Interchangeability

i-FRAME[™] Power Ends Fit 7 Different Process Pumps

Minimize inventory, reduce downtime.



Model 3196
i-FRAME[™]
Process Pumps



Model CV 3196
Non-Clog
Process Pumps



Model HT 3196
High Temperature
Process Pumps



Model LF 3196
Low Flow ANSI
Process Pumps



Model 3198
PFA TEFLON[®]-Lined
Process Pumps



Model 3796
Self-Priming
Process Pumps



Model 3996
In-Line Process
Pumps

Interchangeability with the world's most installed ANSI Process Pump

The Model HT 3196 is completely interchangeable dimensionally with the Model 3196. In addition, all internal components are common between models except for the casing. The *i-FRAME*[™]

power end provides common inventory for Models 3196, CV 3196, HT 3196, LF 3196, NM 3196, 3198, 3796, and 3996.

High Temperature Pumping Expertise

In addition to ANSI Process Pump Expertise, ITT-Goulds Pumps delivers decades of premier experience in centerline mounted, high temperature pump applications with thousands of pump models installed including the Models 3700, 3910, 3900, 3600, 3620, 3640, 3181, and high temperature vertical turbine pumps.

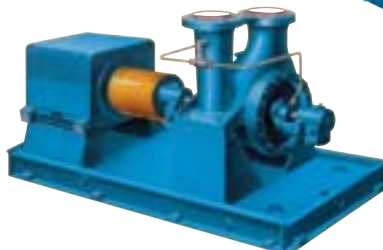
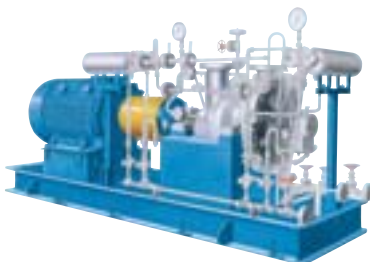

Goolds HT 3196 LF Designed for High Temperature, Low Flow Services

Reduced Radial Loads For Optimum Reliability

Radial loads are reduced by as much as 85% compared to end suction expanding volute pumps at low flows. Bearing, mechanical seal and overall pump life are optimized.

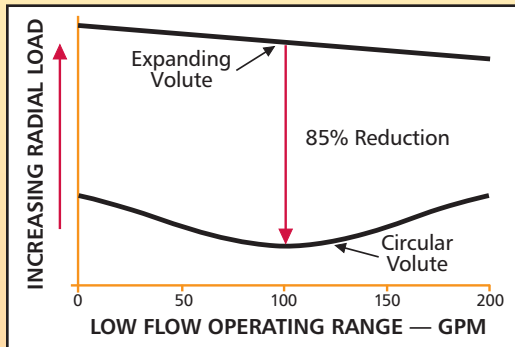

HT 3196 LF PUMP CURVE

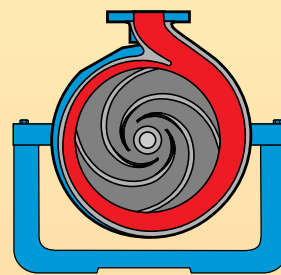

EXPANDING VOLUTE PUMP

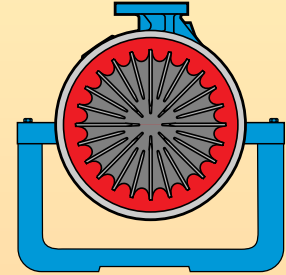

HT 3196 LF CIRCULAR VOLUTE PUMP

Options High and Low Temperature Capability

Goolds offers users a variety of options to meet specific plant and process requirements.



HEAT JACKET

Economical clamp-on jacket provides practical method of heating or cooling the casing. Excellent heat transfer characteristics. Easy to install or remove for pump servicing.



JACKETED SEAL CHAMBER

Maintains proper temperature control of sealing environment. Ideal for maintaining temperature for services such as molten sulphur and polymerizing liquids. Available in BigBore™ and TaperBore™ designs.



CUSTOM FITTED INSULATED FABRIC THERMAL JACKET

Insulates and provides thermal retention of the process fluid within the pump. Insulation jackets are custom fitted and easily removable for installing and servicing the pump.

High Temperature Seal Selection

Shaft Sealing Systems

The most difficult challenge for pumping hot fluids is to effectively seal the rotating shaft from emitting excessive or undesirable fluids into the atmosphere for the purposes of safety and equipment reliability. The selection of the optimum sealing device for specific pumping systems is simplified by combining the world's premier sealing suppliers with the perfect high temperature pumping system.

Single and dual cartridge mechanical seals for moderate temperature applications.

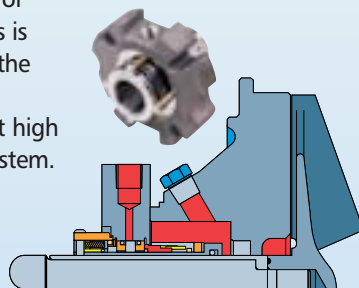

Big Bore™

Multiple high temperature sealing devices and mechanical seal flushing systems are designed and available for a multitude of challenging high temperature sealing applications. The standard HT 3196 configuration includes graphite packing rings in a standard bore box for basic high temperature fluid applications.

Single and dual cartridge mechanical seals for high temperature applications.

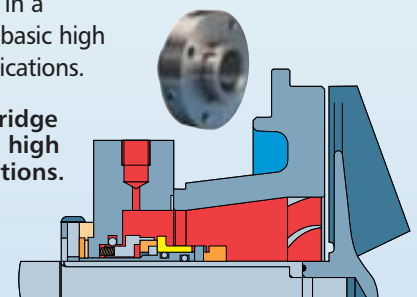

Taper Bore™ Plus

Seal Flush Plans

All ANSI B73.1 seal flush and cooling plans are available to control emission levels and meet seal installation requirements. Goulds can also provide other special arrangements of user preference.

CPI PLAN 7311
By-pass flush lubricates single seal faces.



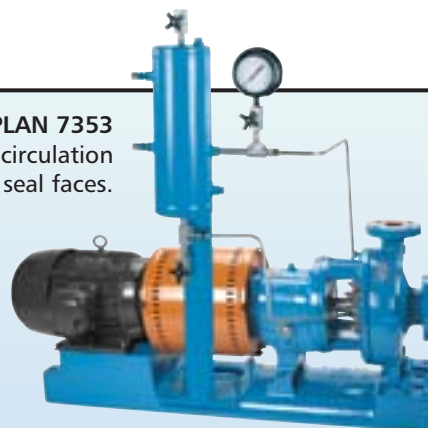

CPI PLAN 7353
Pressurized circulation lubricates double seal faces.

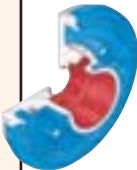

Engineered Seal Chamber Selection Guide

- A** Ideally suited
- B** Acceptable
- C** Not Recommended

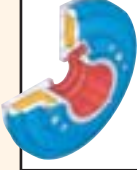
		SERVICE												
		Water-Based Liquids with Flush	Entrained Air or Vapor	Solids 0-10%, no Flush	Solids Greater than 10% with Flush	Paper Stock 0-5%, no Flush	Paper Stock 0-5%, with Flush	Slurries 0-5%, no Flush	High Boiling Point Liquids, no Flush	Temperature Control	Self-Venting and Draining	Seal Face Heat Removal	Molten or Polymerized Liquid, no Flush	Molten or Polymerized Liquid with Flush
	Standard Bore <i>Designed for packing. Also accommodates mechanical seals.</i>	A	C	C	B	C	B	C	C	C	C	C	C	C
	BigBore™ <i>Enlarged chamber for increased seal life through improved lubrication and cooling.</i>	A	B	C	A	C	A	C	C	C	B	A	C	C
	Patented TaperBore™ PLUS <i>Lower seal face temperatures, self-venting and draining. Solids and vapors circulated away from seal faces.</i>	A	A	A	C	A	—	A	A	C	A	A	C	C
	Jacketed Patented TaperBore™ PLUS <i>Maintains proper temperature control (heating or cooling) of seal environment.</i>	A	A	A	C	—	—	A	A	A	A	A	A	A
	Jacketed BigBore™ <i>Maintains proper temperature control (heating or cooling) of seal environment.</i>	A	B	C	A	—	—	C	C	A	C	A	A	A

Baseplate Mounting Systems

Goulds offers a complete range of pump mounting systems to meet plant requirements; make installation and maintenance easier.

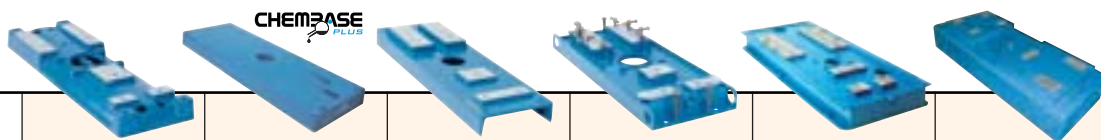

Baseplate Selection Guide	CAMBER TOP CAST IRON Preferred standard of process industries. Rigid and corrosion resistant, it is the best value in the industry today.	CHEMBASE PLUS™ Polymer concrete construction provides exceptional rigidity & corrosion resistance. ANSI 1991 dimensional.	FABRICATED STEEL An economical choice that meets ANSI/ASME B73.1 dimensional requirements.	ENHANCED FEATURE FABRICATED STEEL Upgraded ANSI baseplate designed to maximize pump operation life and ease installation. Meets API-minded chemical pump users' toughest requirements.	ADVANTAGE Heavy duty PIP compliant fabricated steel baseplate.	POLYSHIELD ANSI COMBO Heavy duty polymer concrete combination baseplate and foundation.
PLANT REQUIREMENTS						
Corrosion Resistance (mild/moderate)						
Corrosion Resistance (severe)						
Machined Pump & Motor Parts						
Circular Grout Holes (4 in. min.)						
Vent Holes (1 in. min.)						
Vent Holes (1/2 in. min.)						
Non-Overhang						
Full Drain Rim						
Built-in Drain Pan (under pump)						
Drain Pan Under Pump						
Baseplate Leveling Screws						
Motor Alignment Adjusters						
Lifting Feature						
Continuous Welding Used						
Flexibly Mounted						
Spring Loaded*						
Available in 304 and 316 SS						
ANSI B73.1-1991 Conformance						
API-610 Conformance						
PIP RESP 002 Conformance						

■ STANDARD ■ OPTIONAL *Engineered option—requires special baseplate

Construction Details All dimensions in inches and (mm).

		<i>STi</i>	<i>MTi</i>	<i>LTi</i>	<i>XLTi</i>
Shaft	Diameter at Impeller	.75 (19)	1 (25)	1.25 (32)	1.5 (38)
	Diameter in Stuffing Box/Seal Chamber (Less Sleeve)	1.375 (35)	1.75 (45)	2.125 (54)	2.5 (64)
		(With Sleeve)	1.125 (29)	1.5 (38)	1.875 (48)
	Diameter Between Bearings	1.5 (38)	2.125 (54)	2.5 (64)	3.125 (79)
	Diameter at Coupling	.875 (22)	1.125 (29)	1.875 (48)	2.375 (60)
	Overhang	6.125 (156)	8.375 (213)	8.375 (213)	9.969 (253)
	Maximum Shaft Deflection	0.002 (0.05)			
Shaft Deflection Index (L ³ /D ⁴) (With Sleeve)	143	116	48	62	
	(Less Sleeve)	64	63	29	25
Sleeve	O.D. thru Stuffing Box/Seal Chamber	1.375 (35)	1.75 (45)	2.125 (54)	2.5 (64)*
Bearings	Radial	6207	6309	6311	6313
	Thrust	3306	3309	7310	3313
	Bearing Span	4.125 (105)	6.75 (171)	6.875 (164)	9.25 (235)
BigBore™ Seal Chamber	Bore	2.875 (73)	3.5 (89)	3.875 (98)	4.75 (120)*
Stuffing Box	Bore	2 (51)	2.5 (64)	2.875 (73)	3.375 (86)*
Power Limits	HP (kW) per 100 RPM	1.1 (.82)	3.4 (2.6)	5.6 (4.2)	14 (10.5)**
Temperature	Maximum Liquid Temperature— Oil/Grease Lubrication without Cooling		350° F (177° C)		
	Maximum Liquid Temperature— Oil Lubrication with High Temp. Option		700° F (370° C)		
Casing	Corrosion Allowance		.125 (3)		

* 17 inch sizes have 2 1/4 inch (57) shaft diameters in stuffing box/seal chamber with sleeve. Shaft sleeve O.D. is 2 1/4 inches (70) for packing and 2 1/4 inches (64) for mechanical seals. Seal chamber bore is 4 1/4 inches (121). Stuffing box bore is 3 1/4 inches (92).

** 17 inch sizes power limit per 100 RPM is 20HP (15kW).



HT 3196 High-Temperature Process Pumps

Rugged Design Features for Extreme Process Services

CONDITION MONITOR (PATENT PENDING)

Constantly measures vibration and temperature at the thrust bearing. Colored LED's indicate general pump health. Provides early warning of improper operation before catastrophic failure occurs.

INPRO VBXX-D HYBRID LABYRINTH SEALS

Prevents premature bearing failure caused by lubricant contamination or loss of oil. Stainless steel rotors for optimal performance in corrosive environments.

CONTINUOUS RENEWABLE PERFORMANCE

Original flow, pressure and efficiency are maintained by simple external adjustment resulting in long-term energy and repair parts savings.

HEAVY DUTY SHAFT AND BEARINGS

Rigid shaft designed for minimum deflection at seal faces — less than 0.002 in. (.05 mm). Bearings sized for 10-year average life under tough operating conditions. Available with or without shaft sleeve.

OPTIMIZED OIL SUMP DESIGN

Increased oil capacity provides better heat transfer for reduced oil temperature. Bearings run cooler and last longer. Contaminants directed away from bearings to magnetic drain plug.

ONE-INCH BULLS EYE SIGHT GLASS

Assures proper oil level critical to bearing life. Allows visual inspection of the oil condition. Bottle oiler optional.

FINNED TUBE OIL COOLER

Delivers supplemental cooling to the oil sump for high process fluid operating temps.

i-FRAME™ POWER END

Designed for reliability, and extended pump life supported by a 3-year warranty.

RIGID FRAME FOOT
Reduces effects of pipe loads on shaft alignment; pump vibration reduced. Especially significant for high process fluid operating temperatures.

MAGNETIC DRAIN PLUG
Standard magnetic drain plug helps protect bearings and prolong life.

MOUNTING FLANGE

Supports optional C-face motor adapter to further ensure shaft alignment stability and accommodates standard ANSI coupling guard.

OIL FLINGER

LTi frame oil flinger complies with API-610.

DUCTILE IRON FRAME ADAPTER

With material strength equal to carbon steel for safety and reliability.

HIGH-STRENGTH A193 B7 STEEL BOLTS AND STUDS

Extends the pressure and temperature retaining capabilities while enhancing safety.

TOP CENTERLINE DISCHARGE

For optimum air handling and self-venting by design.

CARBON GRAPHITE CASE GASKET AND IMPELLER O-RING

For positive sealing at elevated temps.

ANSI CLASS 300 CASING

Wall thickness increases reliability and longer casing life.

FULLY OPEN IMPELLER

Preferred design for handling solids that also allows adjustment to maintain original efficiencies over time.

ANSI CLASS 300 FLANGES

Raised face flanges for positive sealing and high-pressure retention and stability at high operating temps comply with ANSI B16.5 requirements.

HEAVY-DUTY STEEL CASING SUPPORT

Rigid design prevents against distortion caused by pipe strain to maintain shaft alignment. Mounting dimensions are identical to foot-mounted pumps, which makes retrofits simple and extends interchangeability.

LOW-THERMAL CONDUCTIVITY 316SS SHAFT

Provides optimum heat dissipation to protect bearings. Minimizes heat transfer from pumpage through shaft to bearings. Bearings run cooler and last longer.

CENTERLINE MOUNTING

Allows for bi-directional thermal growth which minimizes shaft deflection and flange loading for improved seal and bearing life.

Goulds Patented *i-FRAME*™ Power Ends

Extended Pump Life Through Intelligent Design

Goulds *i-FRAME*™ Power Ends are the result of 160 years of design experience, customer interaction, and continuous improvement. Customers get extended Mean Time Between Failure (MTBF) and lower life cycle costs (LCC)... guaranteed!

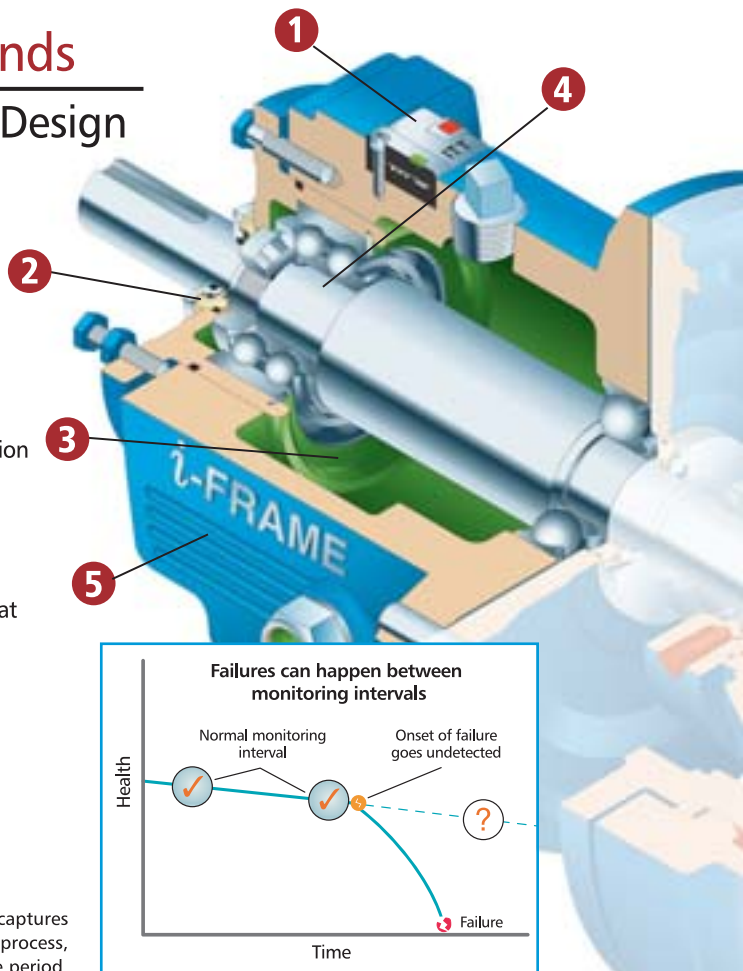

1 Condition Monitor



The heart of the *i-FRAME*™, the condition monitor unit continuously measures vibration and temperature at the thrust bearing and automatically indicates when pre-set levels of vibration and temperature have been exceeded, so that changes to the process or machine can be made before failure occurs.

A visual indication of pump health makes walk-around inspections more efficient and accurate. The result is a more robust process to monitor and maintain all your ANSI pumps so that your plant profitability is maximized.

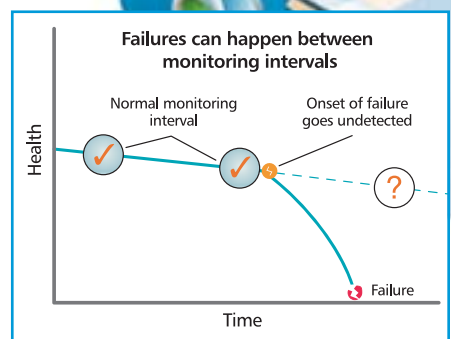

A reliability program centered around walk-arounds captures equipment condition on average once a month; the failure process, however, can begin and end quite frequently within this time period.

2 Inpro VBXX-D Hybrid Bearing Isolators

Most bearings fail before reaching their potential life. They fail for a variety of reasons, including contamination of the lubricant. INPRO VBXX-D has long been considered the industry standard in bearing lubricant protection. The *i-FRAME*™ now improves upon that design by offering stainless steel rotors, for maximum protection against contaminants and the corrosive effects of seal leakage or environmental conditions. These seals are non-contacting and do not wear.

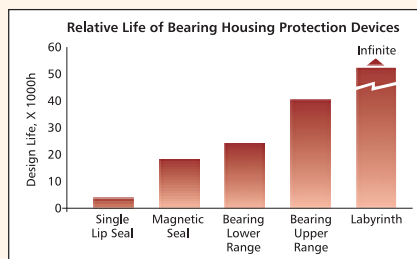

3 Optimized Oil Sump Design

Internal sump geometry is optimized for longer bearing life. Sump size increased by 10%-20% results in better heat transfer and cooler bearings. Contoured design directs contaminants away from bearings, to the magnetic drain plug for safe removal.

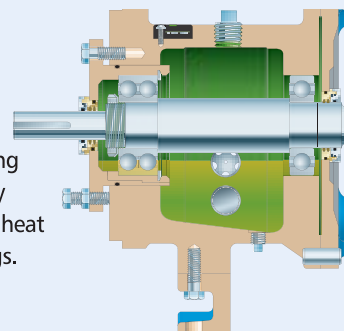

Larger Means Cooler
 GOULDS
 Industry Average

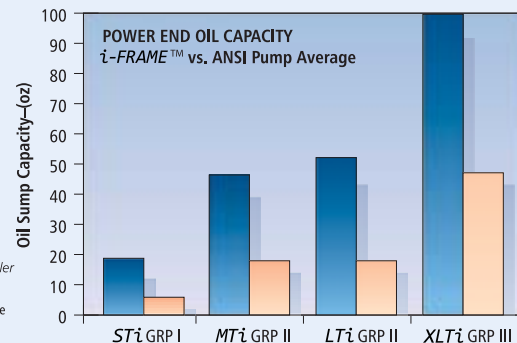

4 Shaft and Bearings Engineered for Maximum Reliability

Every model 3196 Power End is engineered and manufactured for optimal pump performance and increased MTBF.

ANSI B73.1 Shaft Specification	Meets	Exceeds
Diameter Tolerance		✓
Surface Finish		✓
Runout	✓	
Deflection		✓

Fatigue life **more than double** that of conventional bearing steels.

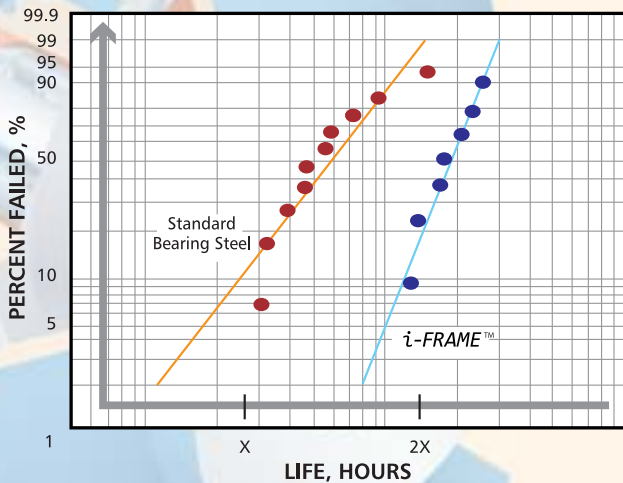

The rugged shaft and bearing combination maintains shaft deflection of less than 0.002 inches at all operating points. The result is longer seal and bearing life.

Premium severe-duty thrust bearings increase bearing fatigue life by 2-5X.

- High purity steels have fewer inclusions than standard steel — better grain structure and wear resistance.
- Heat treatment of bearing elements increases hardness for increased fatigue life.

Forty-degree contact angle on the *MTi* thrust bearing for higher thrust load capability.

- 35% higher dynamic load rating vs. major competitor.
- Increases L'10 bearing life 2X.

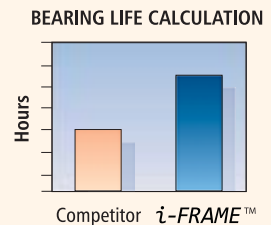

5 *LTi* Power End for High Load Applications

Increased L'10 Bearing Life 150% to 200% on the Toughest Applications

Ideal for tough conditions when a power end is pushed beyond ANSI limits: operating at low flows and higher heads, pumping high specific gravity liquids, fluctuating process conditions, overhung belt drive.

Oversized shaft and bearing assembly significantly expands the limits for long, trouble-free bearing and seal life. On high load applications, the *LTi* power end improves bearing life 150%–200%; oil operating temperature reduced by 45°F (25°C).

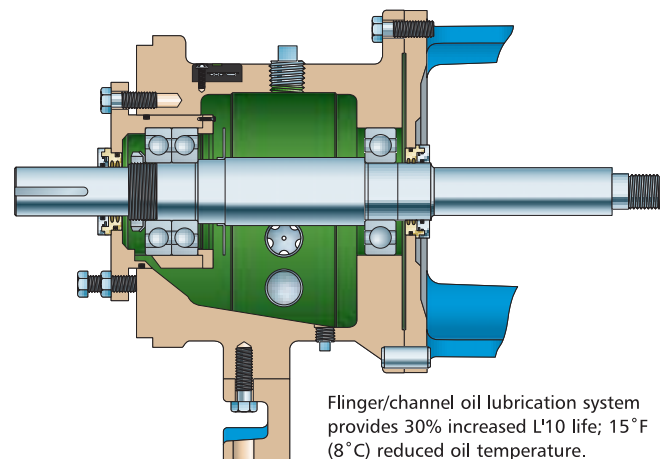

Flinger/channel oil lubrication system provides 30% increased L'10 life; 15°F (8°C) reduced oil temperature.



Duplex thrust bearings (40°/40° angular contact) with machined brass cages, are ideally sized for high load applications.



Oversized shaft with duplex thrust bearings provide increased L'10 by 40%.

Our Guarantee

We are so confident that the *i-FRAME*™ is the most reliable Power End in the industry, that we are proud to offer a standard 5-year warranty on every *i-FRAME*™ ANSI Process Pump.



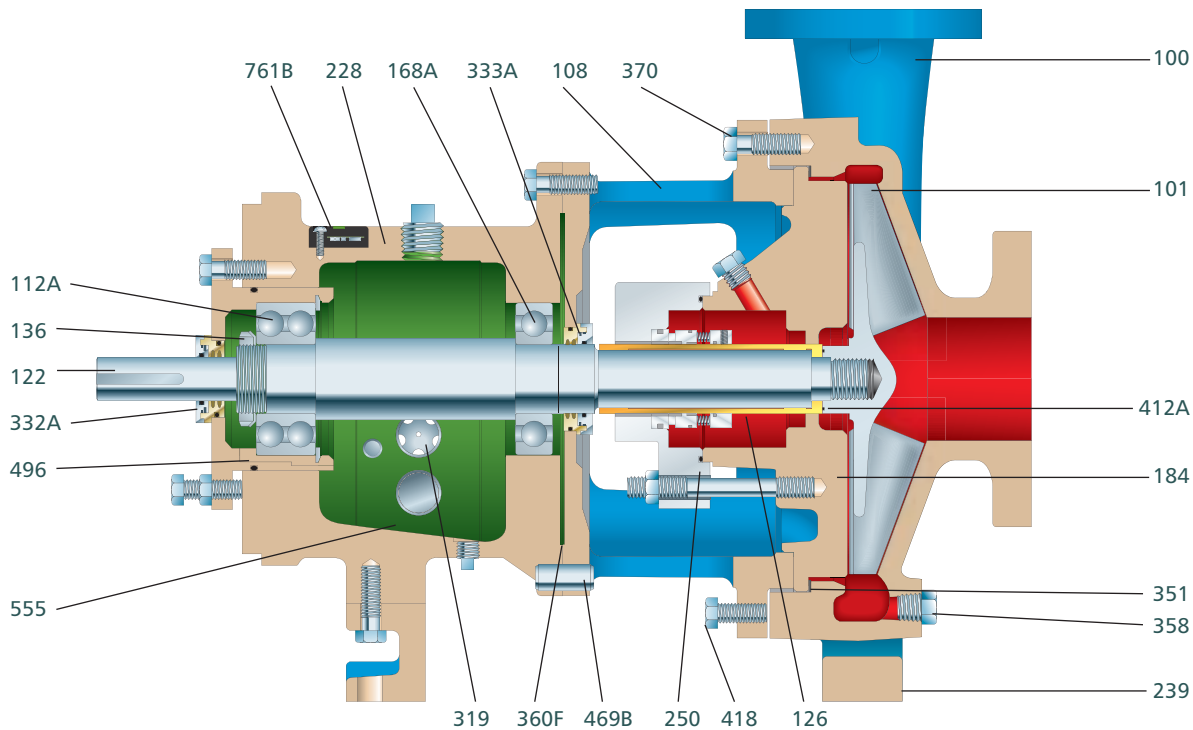

Parts List and Materials of Construction

Item Number	Part Name	MATERIAL					
		Carbon Steel	Ductile Iron	316SS	CD4MCu	Alloy 20	Hastelloy C
100	Casing	CS	316SS	316SS	CD4MCu	Alloy 20	Hastelloy C
101	Impeller		Ductile Iron	316SS	CD4MCu	Alloy 20	Hastelloy C
106	Stuffing Box Packing	Graphite					
108	Frame Adapter	Ductile Iron					
112A	Thrust Bearing	Double Row Angular Contact*					
122	Shaft—Less Sleeve (Optional)		316SS		316SS	Alloy 20	Hastelloy C
122	Shaft—With Sleeve				316SS		
126	Shaft Sleeve		316SS			Alloy 20	Hastelloy C
136	Bearing Locknut and Lockwasher	Steel					
168A	Radial Bearing	Single Row Deep Groove					
184	Stuffing Box Cover (Packed Box)		316SS		CD4MCu	Alloy 20	Hastelloy C
184	Seal Chamber (Mechanical Seal)	Ductile Iron		316SS	CD4MCu	Alloy 20	Hastelloy C
228	Bearing Frame	Cast Iron (Ductile Iron for STI Group)					
239	Casing Support	Fabricated Steel					
250	Gland		316SS		CD4MCu	Alloy 20	Hastelloy C
370H	Stud/Nut, Cover-to-Adapter	304SS					
319	Oil Sight Glass	Glass/Steel					
332A	INPRO® Labyrinth Oil Seal (Outboard)	Stainless Steel/Bronze					
333A	INPRO® Labyrinth Oil Seal (Inboard)	Stainless Steel/Bronze					
351	Casing Gasket	Graphite					
358	Casing Drain Plug (Optional)		316SS		CD4MCu	Alloy 20	Hastelloy C
360F	Gasket, Frame-to-Adapter	Buna					
360C	Gasket, Bearing End Cover	Cellulose Fiber with Binder					
370	Cap Screw, Adapter-to-Casing	304SS					
412A	O-ring, Impeller	Graphite					
418	Jacking Bolt	304SS					
444	Backplate (Dynamic Seal Option)		316SS		CD4MCu	Alloy 20	Hastelloy C
469B	Dowel Pin, Frame-to-Adapter	Steel					
496	O-ring, Bearing Housing	Buna Rubber					
555	Bearing Frame Finned Cooler	Steel/Copper					
761B	Condition Monitor	Stainless Steel/Epoxy					

*LTI Power End features Duplex Angular Contact

® Teflon is a registered trademark for Fluoropolymer Resins, Films, Fibers manufactured by DuPont.

Dimensions Model HT 3196

All dimensions in inches and (mm).
Not to be used for construction.

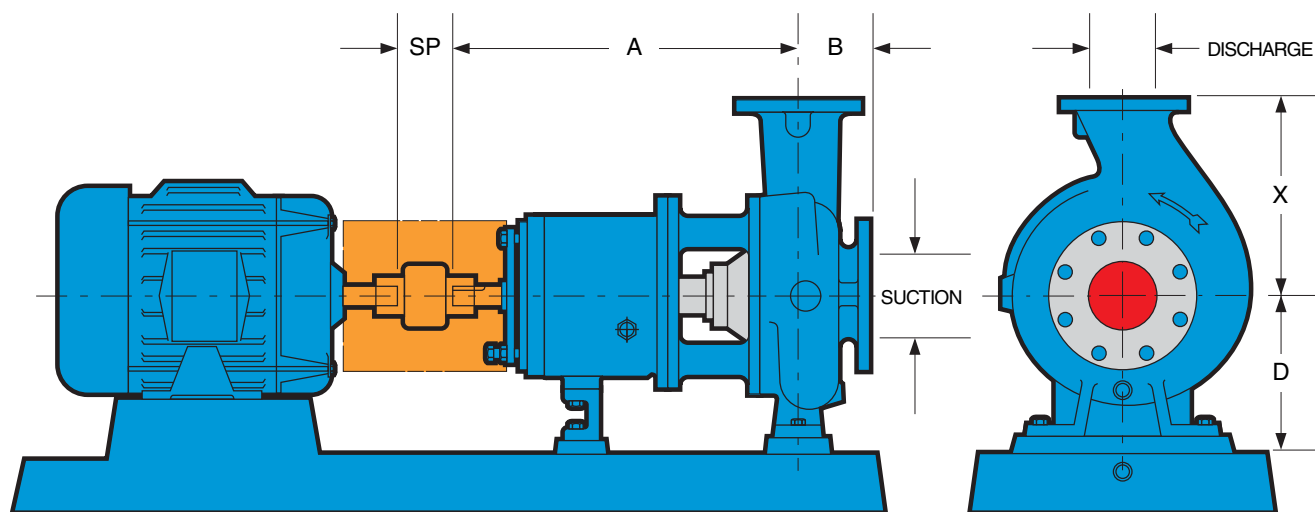

DIMENSIONS										
Group	Pump Size	ANSI Designation	Discharge Size	Suction Size	X	A	B	D	SP	Bare Pump Weight Lbs. (kg)
STi	1x1½-6	AA	1	1½	6.5 (165)	13.5 (343)	4 (102)	5.25 (133)	3.75 (95)	84 (38)
	1½x3-6	AB	1½	3						92 (42)
	2x3-6		2	3						95 (43)
	1x1½-8	AA	1	1½						100 (45)
	1½x3-8	AB	1½	3						108 (49)
MTi / LTi	3x4-7	A70	3	4	11 (280)	19.5 (495)	4 (102)	8.25 (210)	3.75 (95)	220 (100)
	2x3-8	A60	2	3	9.5 (242)					220 (91)
	3x4-8	A70	3	4	11 (280)					220 (100)
	3x4-8G	A70	3	4						200 (91)
	1x2-10	A05	1	2	8.5 (216)					220 (100)
	1½x3-10	A50	1½	3		230 (104)				
	2x3-10	A60	2	3	9.5 (242)		265 (120)			
	3x4-10	A70	3	4	11 (280)		275 (125)			
	3x4-10H	A40	3	4	12.5 (318)		305 (138)			
	4x6-10G	A80	4	6	13.5 (343)		245 (111)			
	4x6-10H	A80	4	6			275 (125)			
	1½x3-13	A20	1½	3	10.5 (267)	19.5 (495)	4 (102)	10 (254)		245 (111)
	2x3-13	A30	2	3	11.5 (292)					275 (125)
	3x4-13	A40	3	4	12.5 (318)					330 (150)
4x6-13	A80	4	6	13.5 (343)				405 (184)		
XLTi	6x8-13	A90	6	8	16 (406)	27.875 (708)	6 (152)	14.5 (368)	5.25 (133)	560 (254)
	8x10-13	A100	8	10	18 (457)					670 (304)
	6x8-15	A110	6	8						610 (277)
	8x10-15	A120	8	10						740 (336)
	8x10-15G	A120	8	10	19 (483)					710 (322)
	8x10-16H		8	10						850 (385)
	4x6-17		4	6	16 (406)					650 (295)
	6x8-17		6	8	18 (457)					730 (331)
	8x10-17		8	10	19 (483)					830 (376)

Hydraulic Coverage Model HT 3196

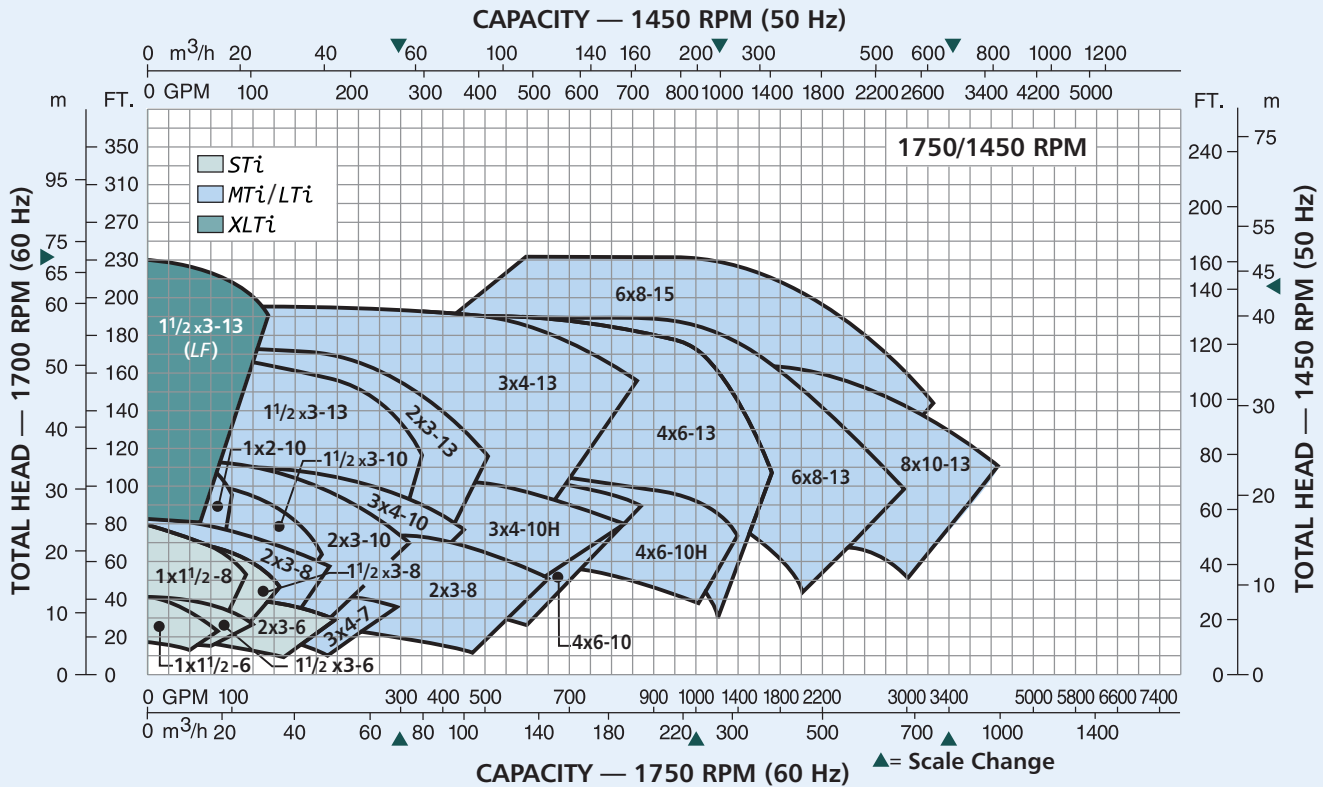
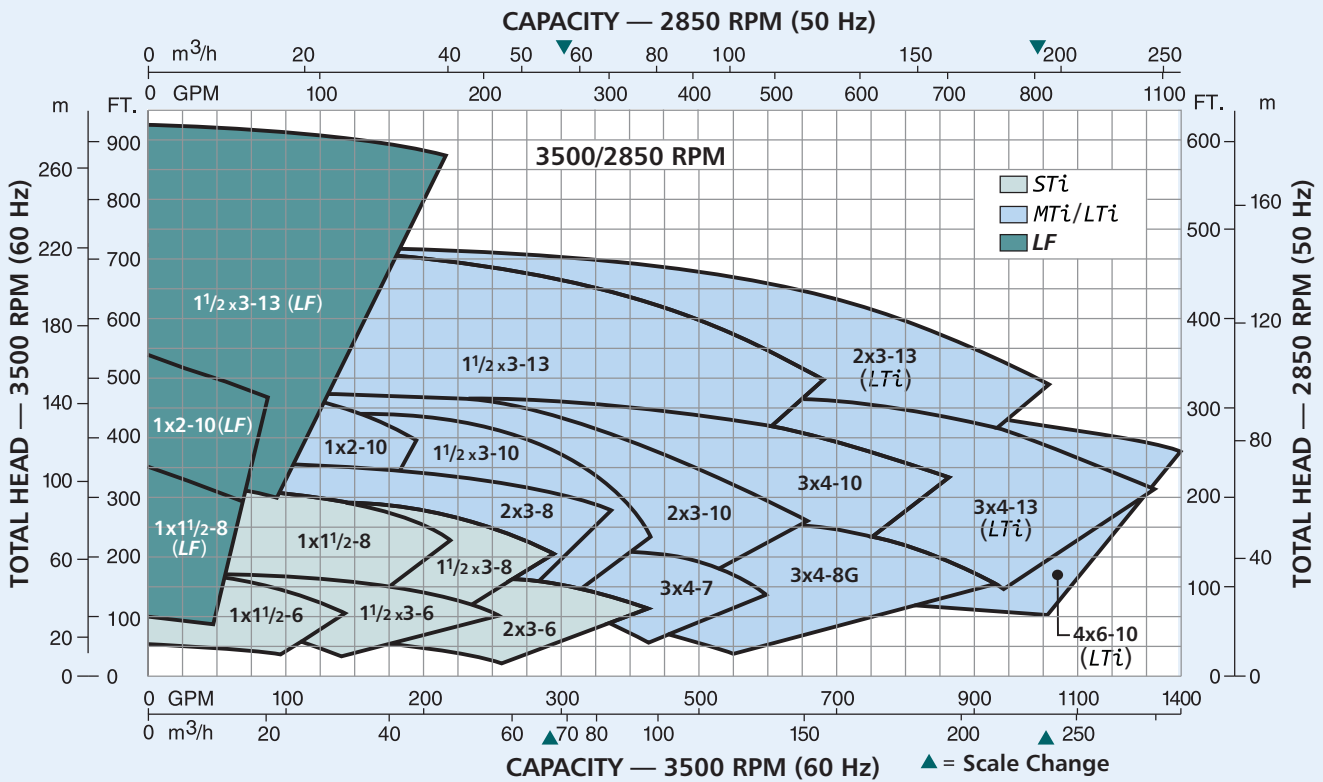



PRO Services®
Extending
Equipment Life...

Product Repair (all types and brands of rotating equipment)

- Service Center Repair
- Field Service
- Parts Supply

Reliability Improvement

- Inventory Management
- Replacement/Exchange
- Turnkey Repair/Installation
- Training

Optimization of Assets

- Predictive Analysis/Condition Monitoring
 - Root Cause Failure Analysis
 - Pump & System Assessments
 - Upgrades – Mechanical & Hydraulic
 - Maintenance Management/Contract Maintenance
-
- Technical Expertise
 - Fast Turnaround
 - Factory Trained Service Personnel
 - Emergency Service – 24 hours/day, 7 days/week
 - Quality
 - ISO and Safety Certified

PROSMART

ProSmart™ encompasses the latest technology* in condition monitoring to transform your Predictive Maintenance program into a Plant Profitability program. It provides a cost-effective solution to maintaining uptime on all of your rotating equipment. ProSmart continuously monitors, analyzes and annunciates an alarm when critical criteria is not met. By identifying, diagnosing, and sounding an alert to potential equipment problems before they have a chance to manifest into unexpected downtime or catastrophic failure, ProSmart helps to assure plant profitability.



ProSmart delivers benefits that go right to the bottom line.

- Extends equipment life
- Optimizes costly “walk arounds” by skilled personnel
- Can help reduce overall equipment failures and the cost of downtime
- Sends alerts prior to potential catastrophic process failures
- Automatically alerts personnel to machine problems
- Consolidates data for equipment optimization (*Patent pending)

ProSmart is a wireless machinery monitoring system that collects and analyzes operating data automatically every 5 seconds. Integrated analysis capabilities provide enhanced data and reporting functions.

PUMPSMART

PumpSmart® is the latest advancement in pump control and protection to reduce energy consumption, increase uptime and decrease maintenance cost. It allows the pump to be right-sized to the application by dialing in the speed and torque which increases flow economy, reduces heat and vibration, and improves overall system reliability.

- **Simplified Pump Control** — PumpSmart was designed specifically to optimize pumping applications and can be used to control a single pump or coordinate between multiple pumps without the need for an external controller.
- **Pump Protection** — PumpSmart guarantees to protect the pump from upset conditions with patented sensorless pump protection algorithms.
- **Smart Flow** — PumpSmart features a sensorless flow function for centrifugal pumps that can calculate the flow of the pump within ± 5% of the pump rated flow.
- **Drive for the DCS** — While most VFDs can only provide basic information, PumpSmart offers unparalleled insight to the pump operation which allows for smoother process control and efficiency.
- **Pump Experts** — PumpSmart is a variable speed drive with pump-specific algorithms imbedded into the drive. With over 150 years of pump knowledge, let the pump experts take responsibility of your pump system.



motralec

4 rue Lavoisier . ZA Lavoisier . 95223 HERBLAY CEDEX
 Tel. : 01.39.97.65.10 / Fax. : 01.39.97.68.48
 Demande de prix / e-mail : service-commercial@motralec.com
www.motralec.com