

GOULDS PUMPS

Pumps for the Sugar Processing Industry



Goulds Pumps

motralec

4 rue Lavoisier . ZA Lavoisier . 95223 HERBLAY CEDEX
Tel. : 01.39.97.65.10 / Fax. : 01.39.97.68.48
Demande de prix / e-mail : service-commercial@motralec.com
www.motralec.com



ITT Industries
Engineered for life

Goulds Pumps and A-C pumps – Performance proven for over 150 years...



Where it counts—in the sugar mill.

Whether it's cane, beet or corn sugar, from Latin American, Asian, African or U. S. production—from

raw juice to crush-crush to lime slurry and more, you'll find Goulds and A-C (Allis-Chalmers) pumps on the job, day-in and day-out,

wherever sugar is being refined. We have been solving problems and supplying pumps to meet the needs of the sugar industry for over 150 years. Visit any sugar mill and you will find a wide variety of Goulds and A-C pumps in service. We have been at the forefront with major “firsts” and improvements, all designed to help serve the sugar industry better. Our refinements include: the first rubber-lined pumps, hard metal pumps, high-alloy components, Shearpellers™ and dynamic seals. Today, we continue seeking new developments and

innovations to extend the performance and service life of our pumps in the sugar processing industry.

Goulds Pumps produces the widest range of pumps for the sugar processing industry of any pump manufacturer in the world; boiler feed pumps, elastomer-lined and hard metal slurry pumps, ANSI

standard process pumps, sealless magnetic drive pumps, water supply and wastewater treatment pumps and UL/FM approved fire pumps.

If you're looking for a dependable supplier of sugar processing pumps with over 150 years of industry experience who understands the problems and challenges you face to

increase production—we are ready to help.

Take a close look at the products in this brochure. They cover an extensive range of pumps for the sugar processing industry—simply stated, Goulds builds quality pumps to meet every one of your requirements.



Goulds Pumps. Everything you need...and more!

A-C Hard-Metal Slurry, Solids Handling Pumps

CW Cane Wash Pump

CWX

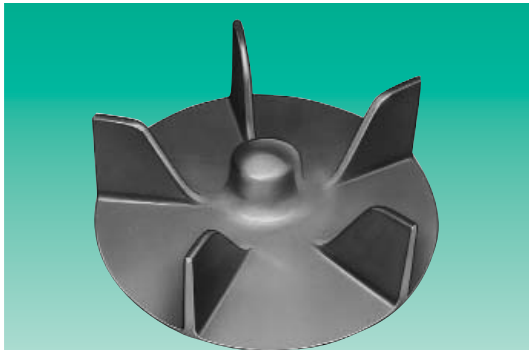
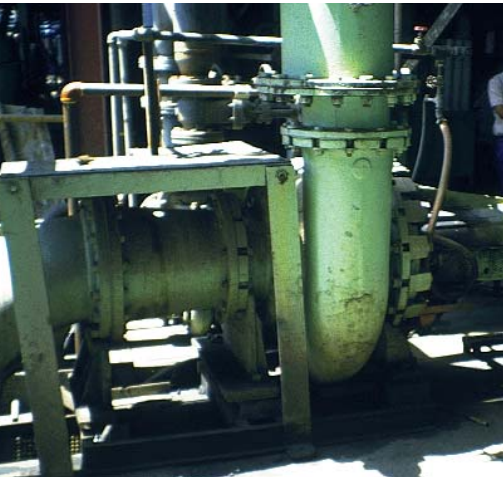
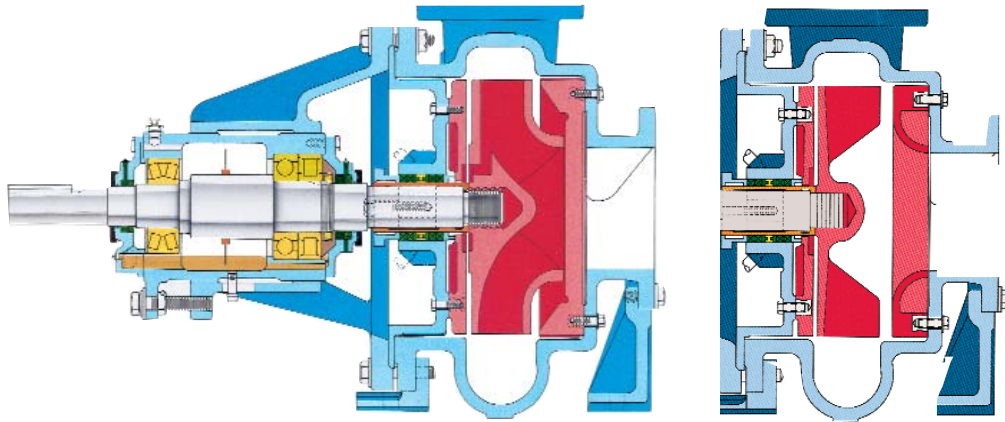

CWX pumps embody an innovative yet time-proven concept in pump design. The unique, patented Shearpeller successfully handles large, stringy or fibrous solids in suspension, up to 25% entrained air in water by volume, highly viscous material plus many other hard to pump slurries.

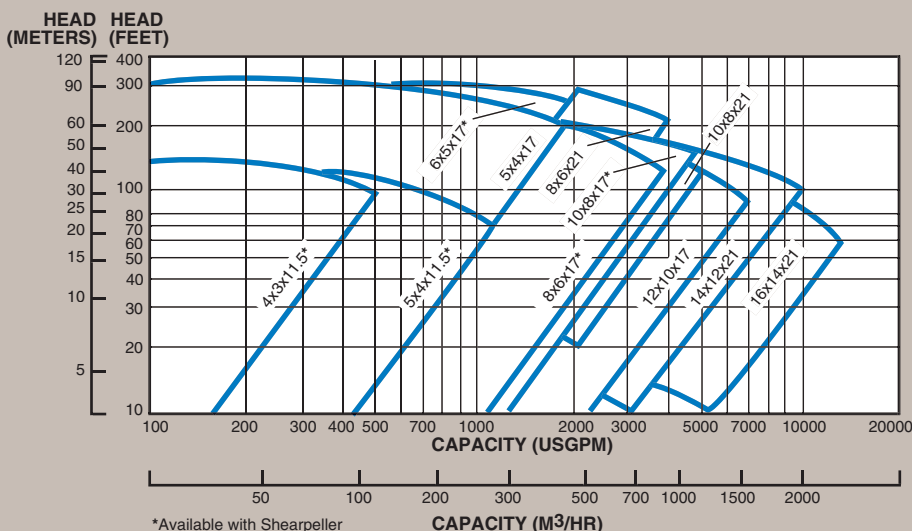

Proven performance in handling liquids with abrasive solids.

The CW Series pumps are designed to handle liquids containing abrasive solids from 1/8" (3mm) to 5" (125mm) in size. The CW is available in abrasive resistant Hi-chrome iron (ASTM A532, Class III Type A Hardened). Available in sizes from 4" (100mm) to 16" suction (400mm), capacities to 13,000GPM (2950m³/hr) and heads to 300ft (90m), the CW Series is capable of handling temperatures up to 250°F (120°C). The CWX Shearpeller version is available for applications with stringy, fibrous slurries. Typical applications for the CW series include cane juice, cane washing, fiber slurries, slurry transfer, lime and clay. The stainless steel shaft sleeves have a hardness of 800 BHN and are sealed at the impeller to prevent leakage. The CW Series pumps are available with the Equisal[®] dynamic seal which eliminates shaft sleeve and packing maintenance and gland water requirements.

CW Design features

- Eleven sizes are built on three power frames to provide maximum interchangeability.
- The back pull-out design allows for routine maintenance without disturbing piping.
- Superior hydraulics assure high efficiencies.
- Replaceable, wear resistant shaft sleeve (800 BHN), suction wear plate and stuffing box wear plates.

CWX Shearpeller Design features

- Five sizes; 4" (100mm) to 10" (250mm).
- Capacities to 5,000GPM (1135m³/hr), heads to 350ft (100m).
- Solids handling to 4.5 inches (115mm).
- Capable of pumping string fibers without clogging and up to 25% air.

SP-Slurry Pro® / 5500

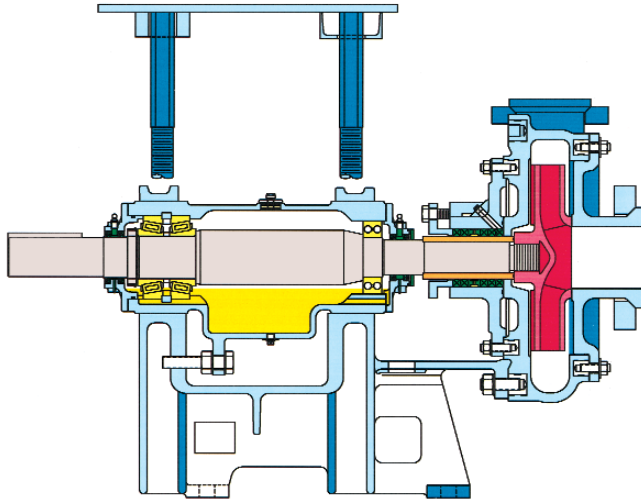

The design of the pumps ensures superior wear life characteristics while providing energy efficient performance and ease of maintenance.

The Slurry Pro / 5500 pump series is designed specifically to handle abrasive and corrosive slurries such as raw juice and lime slurry. The head and capacity of these pumps can be adjusted to suit a wide range of operating conditions. Available in 22 sizes with flow ranges to 14,000 GPM (3180 m³/hr) and heads to 400 ft (121 m). The SP / 5500 line has standard features which provide for ease of maintenance which maximizes uptime wherever these pumps are used in sugar processing.

Design features

- The front pull-out design allows for wet end inspection and replacement without disturbing discharge piping or power end drive arrangement.
- Separate suction cover / wearplate is provided in all sizes for easy removal and replacement.
- Standard high chrome, heavy metal casing sections assure maximum operating life.
- 400 series stainless steel shafts are hardened to 500 Brinell to assure long wear life.
- Oil lubricated antifriction bearings with grease lubricated double lip seals provide long life under extreme loads.

Options available

- Oversized stuffing box to accommodate slurry seals.
- Optional dynamic seal eliminates shaft sleeve and packing maintenance and gland water requirements.
- Corrosive and abrasive resistant alloy 2205 duplex stainless steel available.

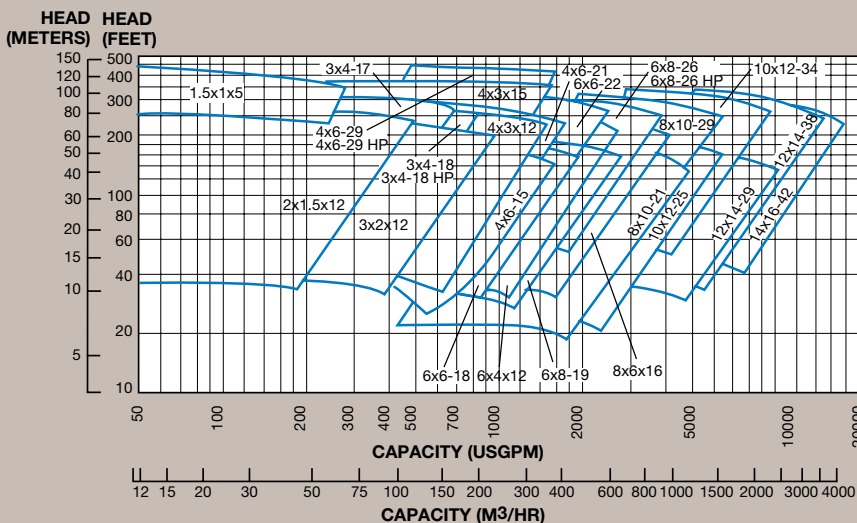

A-C Elastomer-Lined Slurry, Solids Handling Pumps

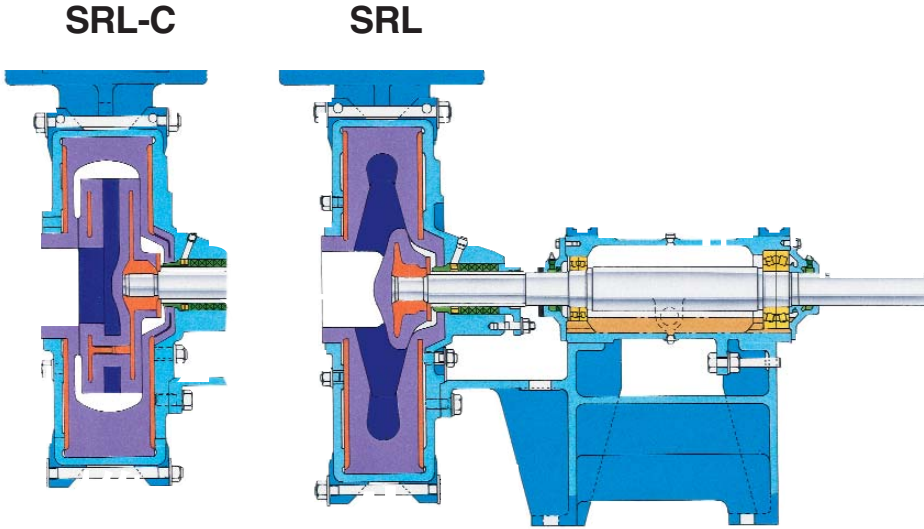

Reliable, long-lasting, cost-effective handling of abrasive and corrosive slurries.

These elastomer-lined pumps have been designed to handle the tough abrasive and corrosive slurries found in sugar refining applications. Rubber-lined pumps are especially well-suited for raw juice service due to the abrasive nature of the liquid. Choose from twelve sizes: 2" (50mm) to 20" (500mm). Flow ranges up to 20,000 GPM (4545 m³/hr) with heads to 140 ft. TDH (40m). The natural rubber linings handle liquid temperatures up to 160°F (70°C) with synthetic linings handling up to 230°F (110°C).

Design features

- Pressure molded natural rubber liners are bonded to skeletons for easy removal and replacement.
- XH-800 series coated stainless steel shaft sleeves are hardened to 800 Brinell to maximize wear life.
- The five discharge positions suit most piping arrangements.

Options available

- Neoprene, nitrile, polyurethane and Hypalon® liners, impellers, and wear plates.
- Hi-chrome iron hard-metal impellers available.
- Stainless-steel fitted (gland, water seal bushing and sleeve) for corrosive applications.
- Stainless-steel detachable stuff box.
- High-pressure casings.
- Pressure-reducing labyrinth gland-bushing for high pressure applications.

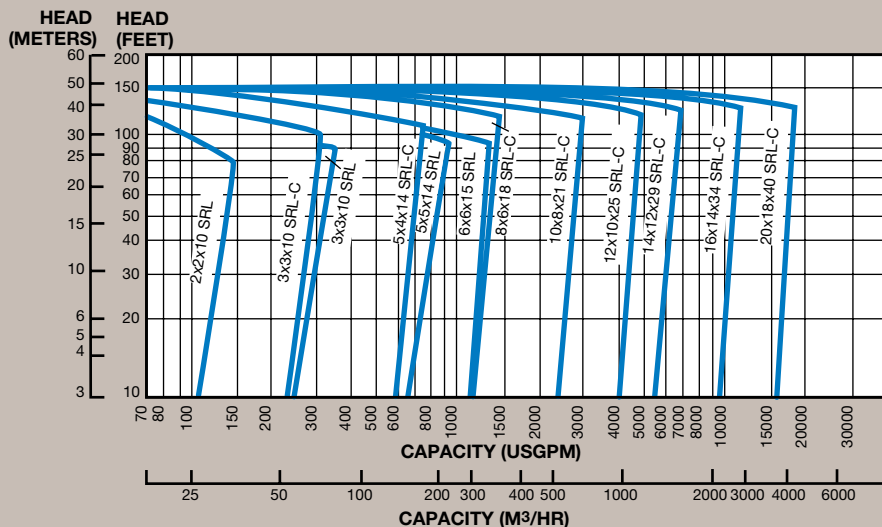
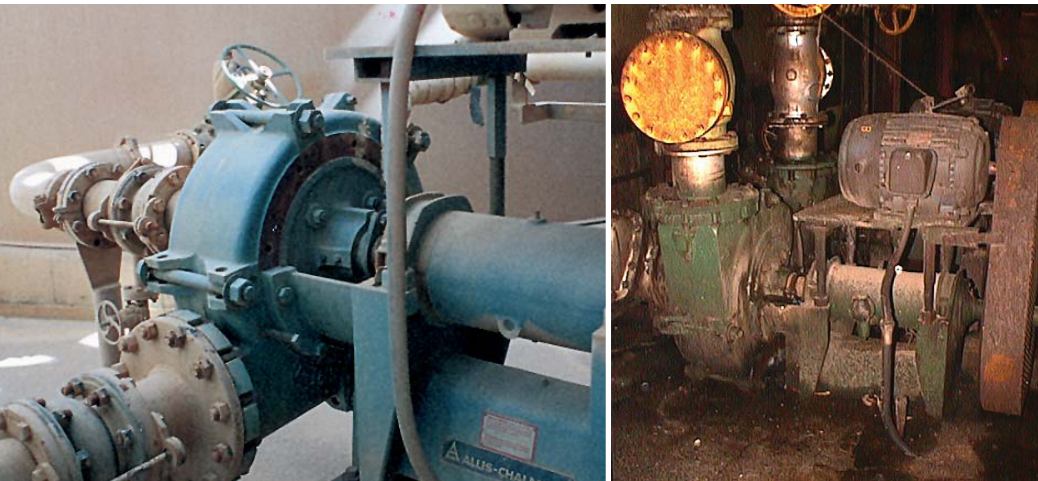

© Trademark of duPont

Vortex Solids Handling Pumps

HS/Whirl-Flo®

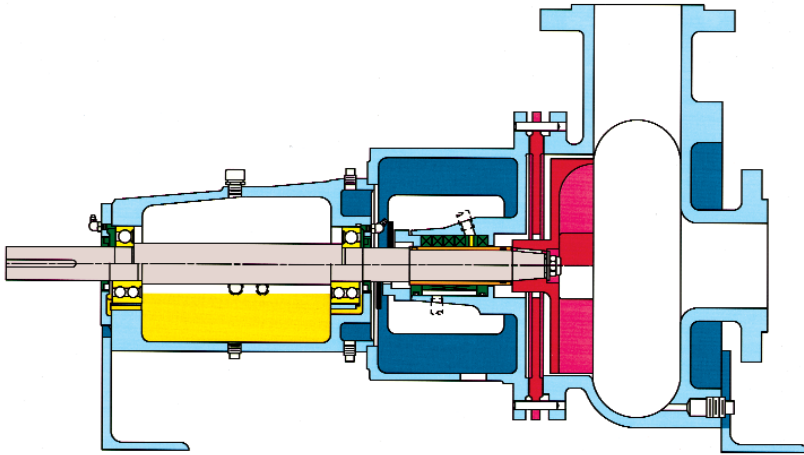

Handle slurries, sludges, stringy material and discharge-sized spherical solids with clog-free dependability.

Fully recessed impellers produce a clear flow path to the pump discharge, allowing the pumping of large solids. Recessed impellers and pump out vanes reduce axial thrust and stuffing box pressure – extending seal, packing, sleeve and bearing life. Vortex pumps are available in sizes from 2" (50 mm) to 10" (250 mm). These pumps are typically used for maceration service and raw juice. Vortex pumps are also used for boiler scrubber applications where their recessed impeller design provides longer service life in this highly abrasive medium.

Whirl-Flo and HS are available in the following materials:

- Cast Iron: ASTM A48; Classes 25 & 35.
- Chromium Iron: ASTM A532, Class III Type A hardened to 600 Brinnell.
- Stainless Steel: AISI 316 or ACI CF-8M (Cast).

Design features

- Solids handling capability to 10" (250 mm).
- Centerline discharge on Whirl-Flo is self-venting to prevent air binding.
- Easy access, back pull-out design without piping disconnects, simplifies maintenance and minimizes downtime.
- Select packing or mechanical seal to suit fluid handling needs.
- Quiet low vibration operation reduces shaft and bearing fatigue. Double or single row bearings are available.

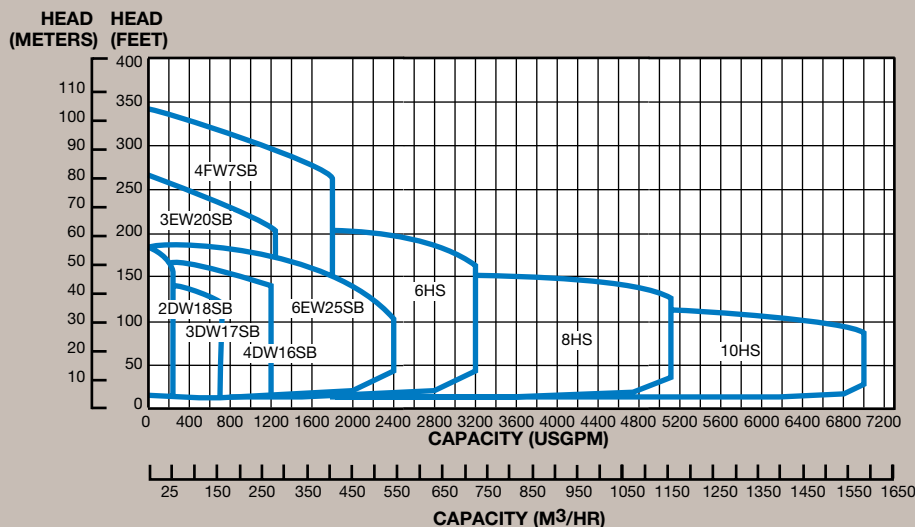
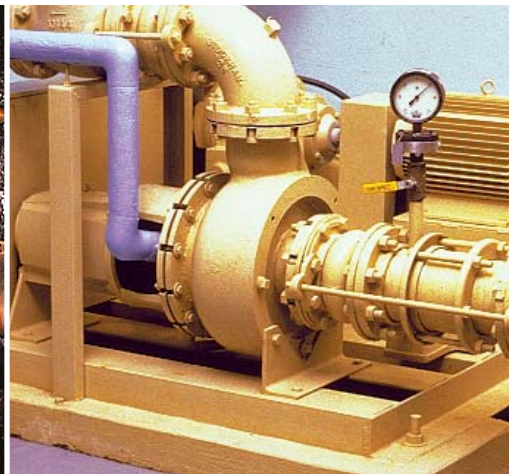
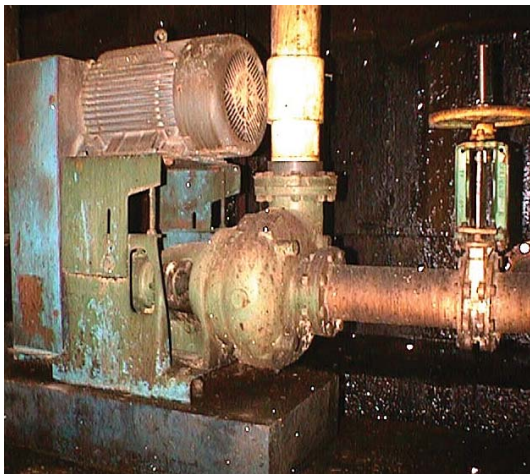

Goolds Pumps for Process Services

3196 XLT-X

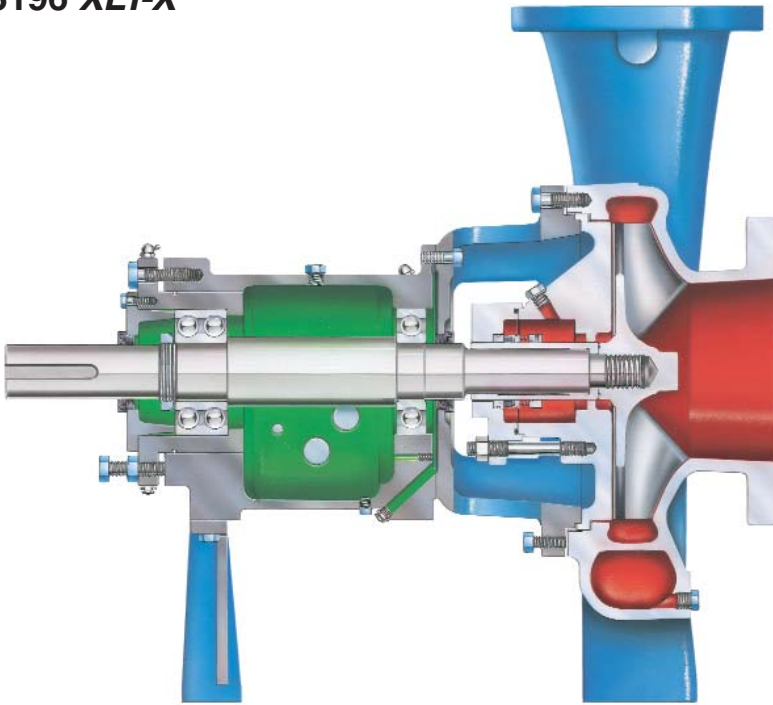

Proven Performance...

Over 500,000 Installations Worldwide

The Goolds 3196 ANSI Process Pump has become the standard for the sugar industry. Today, over a half million process installations attest to its remarkable performance. Users in the sugar processing industries can make no better choice than the best – Goolds Model 3196.

Four Design Features for Long Pump Life:

- **Impeller:** Designed for long-term, maintainable performance and minimum hydraulic loads for maximum reliability.
 - **Seal Chamber:** Designed for favorable seal environment – proper heat dissipation and lubrication of seal faces. The design also handles tough services: liquids containing solids, air or vapors.
 - **Power End:** Designed for optimum bearing life, effective oil cooling, and minimum shaft deflection.
 - **Baseplate:** Rigid to withstand forces and moments of plant piping systems.
- Capacities to 6,000 GPM (1364 m³/h)
 - Heads to 730 feet (223 m)
 - Temperatures to 700° F (372° C)
 - Pressures to 375 PSIG (2586 kPa)
 - 29 sizes

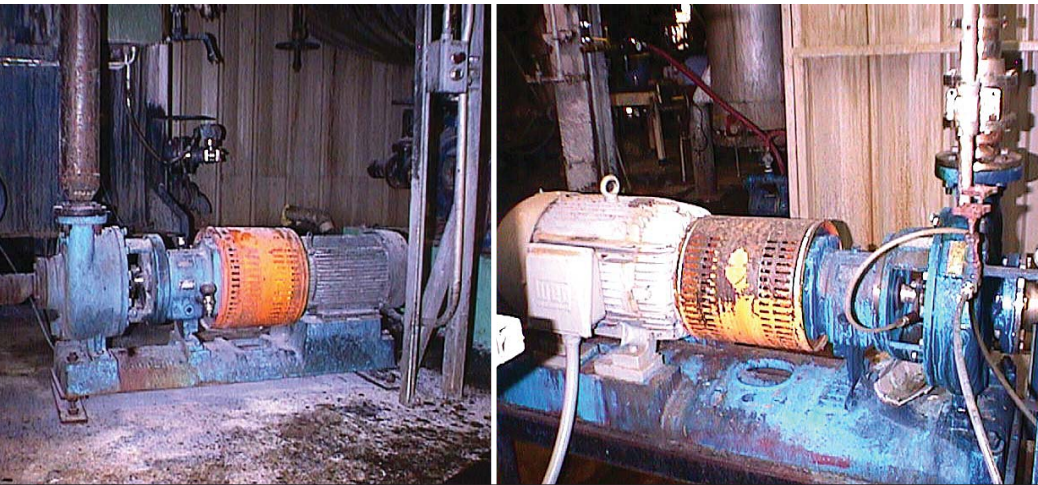

IC Series

In plants where ISO standard process pumps are preferred, Goolds offers the IC series. Available in a variety of models and metallurgies, the IC pump provides life cycle enhancing features and world class performance.

- Capacities to 1980 GPM (450 m³/h)
- Heads to 482 feet (150 m)
- Temperatures to 350° F (177° C)
- 28 sizes

3175/3180/3185

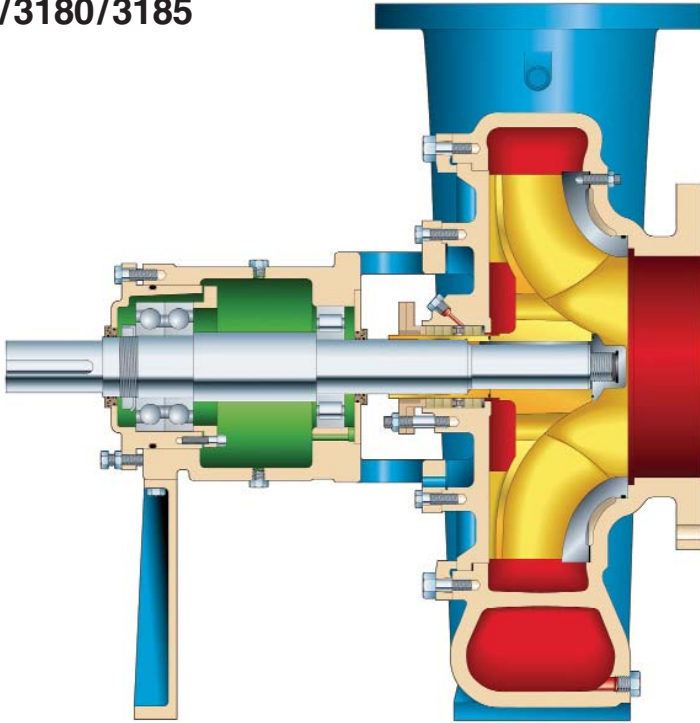

Heavy duty process pumps designed to handle all of your sugar process pumping applications.

Design features

- Ease of adjustment to maintain optimum performance. By adjusting the impeller clearance at the bearing frame, wide open accessibility to the bolts assists in obtaining a positive clearance with minimal effort.
- Clamped sideplate for maximum reliability and zero leakage. The clamped sideplate provides consistent alignment with the impeller. This results in improved efficiency and more even wear over the life of the pump. Also provides reliable leak-free seal with clamped gasket and o-ring.
- Minimum hydraulic loads for maximum reliability. Casing and impeller specifically designed to increase efficiencies, and decrease internal hydraulic loads to improve power end and overall pump reliability.
- Capacities to 28,000 GPM (6360 m³/h)
- Heads to 410 feet (125 m)
- Temperatures to 450° F (232° C)
- Pressures to 285 psig (16 bar)
- 83 metric and english dimension sizes to choose from.

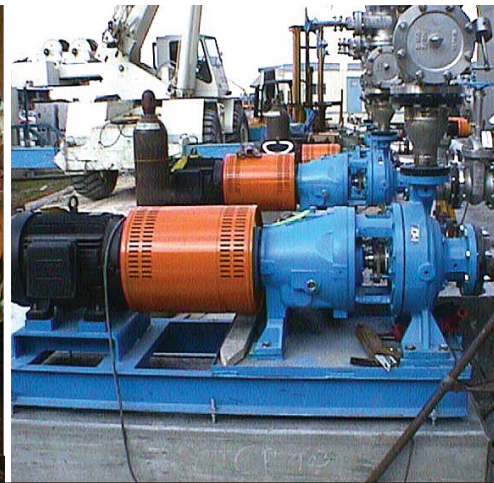
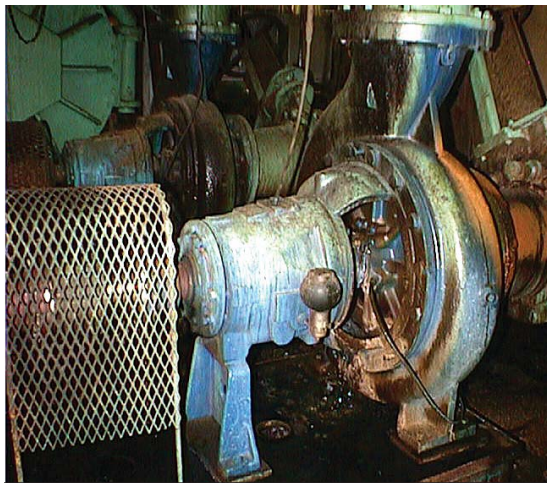

Double Suction Splitcase Pumps

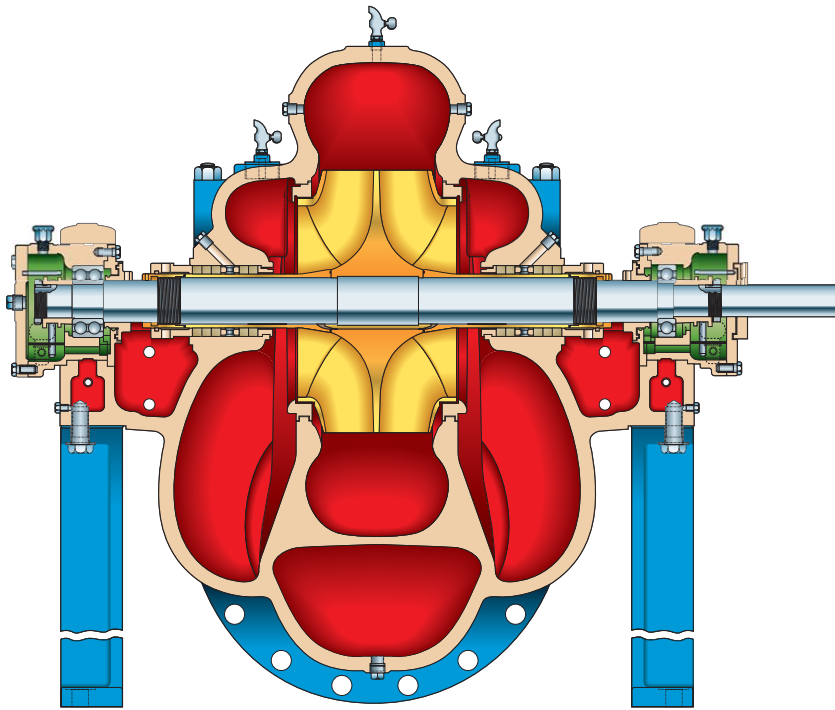

Axially split-case pumps for high efficiency, energy savings and quiet operation. Splitcase pumps are used throughout sugar processing plants for high flow, high head applications such as limed juice, injection water, water supply, and transfer.

Design features

- **Double Suction/Dual Volute***
Balanced axial and radial loading for long service life and reduced maintenance.
- **Horizontally Split Casing**
In-line suction and discharge in lower half casing simplify piping layouts and allow removal of the upper half casing for easy inspection.
- **Wear Rings**
Easily replaceable casing and impeller wear rings protect valuable components, reducing overall cost of operation.
- **Sealing Flexibility**
Regardless of the liquid being pumped, Goulds has the sealing arrangement to fit the application. A wide variety of mechanical seals and packing are available.
- **Installation Versatility**
 - Vertical Mounting*
 - Bottom Suction*
 - Clockwise/Counterclockwise Rotation
- Capacities to 180,000 GPM (40878 m³/h)
- Heads to 850 feet TDH (260 m)
- Temperatures to 350° F (177° C)
- Working pressures to 400 psi (2750 kPa)
- Suction sizes – 3" (76 mm) to 78" (1981 mm)

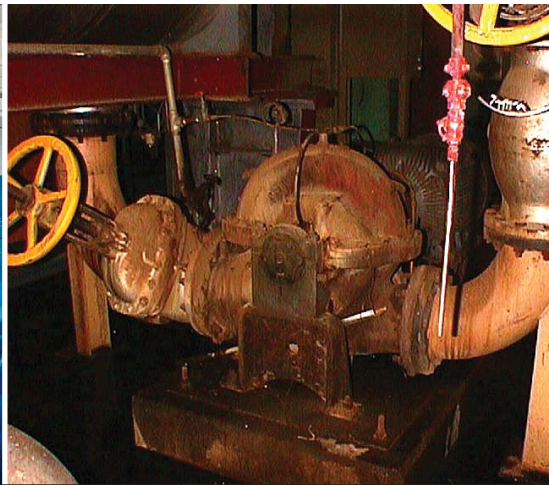

*Not available on all models or sizes.

Goolds Multistage Pumps

MP Multistage Pumps

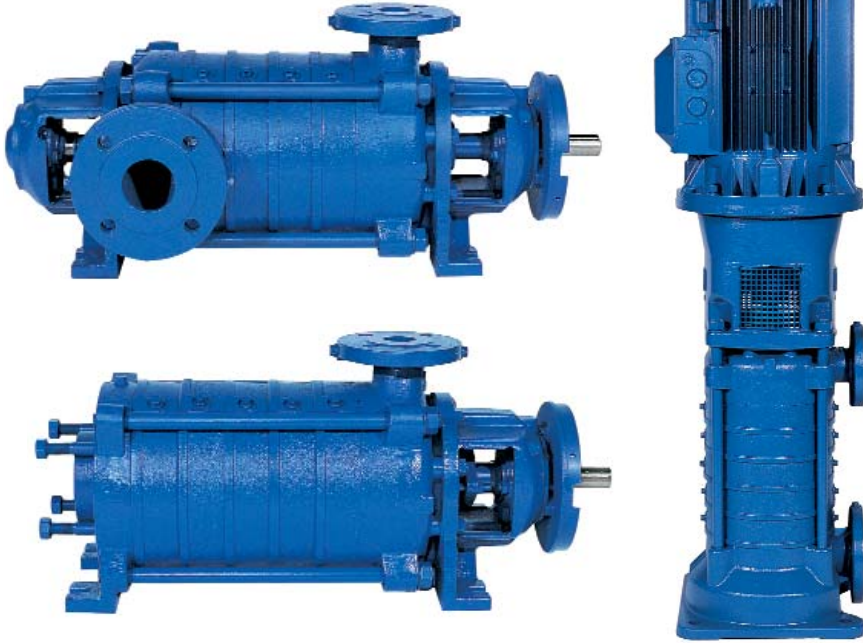

Heavy duty, high pressure multi-stage pumps for a variety of services. Whether water supply for irrigation or boiler feed, Goolds has the pump you can depend on.

A variety of pump configurations will fulfill your application requirements.

Performance Range:

Capacities to 8800 USgpm (2000 m³/h)
Heads to 1640 feet (500 m)

Sizes:

3" (76 mm) - 12" (305 mm) discharge

Max. temperature:

280°F (140°C)

Max. casing pressure:

800 psig (55 bar)

Vertical Turbine



A wide range of vertical turbine pumps are available for irrigation, water supply, and cooling tower service.

Performance Range:

Capacities to 100,000 GPM (22710 m³/h)
Heads to 3500 feet (1067 m)

Sizes:

Over 150 sizes to choose.

Max. temperature:

Temperatures to 450°F (232°C)

Pick Your Perfect Process Pump

No one in the sugar industry offers the broad range of process pumps that Goulds does!

Whether it's for pumping severe corrosives, abrasive slurries, fibrous/stringy solids, high temperature liquids, hazardous fluids, low flow or high capacity services - Goulds has a perfect, reliable solution. The Goulds selection of pump solutions includes horizontal and vertical configurations in a range of alloy and non-metallic constructions, sealed and sealless.



PRO Service Centers: Worldwide...Wherever You Need Us.

PRO Service engineers and technicians are experienced with servicing all types of pumps and rotating equipment. Customers utilize PRO Services for commissioning, troubleshooting, and field repairs of pumps, pumping systems and other pieces of rotating equipment.



Member of
Hydraulic
INSTITUTE

Goulds Pumps



ITT Industries
Engineered for life

motralec

4 rue Lavoisier . ZA Lavoisier . 95223 HERBLAY CEDEX
Tel. : 01.39.97.65.10 / Fax. : 01.39.97.68.48
Demande de prix / e-mail : service-commercial@motralec.com
www.motralec.com

