

# NB, NBG

## Installation and operating instructions

GB D F I E P GR NL S FIN DK  
PL RU H SI HR SER RO BG CZ SK TR  
EE LT LV UA



## **(GB) Declaration of Conformity**

We, Grundfos, declare under our sole responsibility that the products NB and NBG, to which this declaration relates, are in conformity with these Council directives on the approximation of the laws of the EC member states:

- Machinery Directive (2006/42/EC).  
Standards used: EN 809: 1998, EN 60204-1:2006.
- ATEX Directive (94/9/EC)  
(Applies only to products with the ATEX markings on the nameplate.)  
Standards used: EN 13463-1: 2001, EN 13463-5: 2003.  
(Declaration of conformity and installation and operating instructions of the motor are enclosed.)  
Notified body holding copy of technical file: KEMA Quality B.V., No 0344. Utrechtseweg 310, 6802 ED, Arnhem, The Netherlands.

## **(F) Déclaration de Conformité**

Nous, Grundfos, déclarons sous notre seule responsabilité, que les produits NB et NBG, auxquels se réfère cette déclaration, sont conformes aux Directives du Conseil concernant le rapprochement des législations des Etats membres CE relatives aux normes énoncées ci-dessous :

- Directive Machines (2006/42/CE).  
Normes utilisées: EN 809: 1998, EN 60204-1: 2006.
- Directive ATEX (94/9/CE)  
(S'applique uniquement aux produits avec norme ATEX citée sur la plaque signalétique).  
Normes utilisées: EN 13463-1: 2001, EN 13463-5: 2003.  
(Déclaration de conformité et notice d'installation et d'entretien du moteur incluses.)  
Copie du fichier technique: KEMA Quality B.V., No 0344. Utrechtseweg 310, 6802 ED, Arnhem, The Netherlands.

## **(E) Declaración de Conformidad**

Nosotros, Grundfos, declaramos bajo nuestra entera responsabilidad que los productos NB y NBG, a los cuales se refiere esta declaración, están conformes con las Directivas del Consejo en la aproximación de las leyes de las Estados Miembros del EM:

- Directiva de Maquinaria (2006/42/CE).  
Normas aplicadas: EN 809: 1998, EN 60204-1: 2006.
- Directiva ATEX (94/9/CE) (se refiere sólo a productos con la marca ATEX en la placa de características).  
Normas aplicadas: EN 13463-1: 2001, EN 13463-5: 2003.  
(Se adjuntan la declaración de conformidad e instrucciones de instalación y funcionamiento del motor.)  
Copia de documentación técnica al Organismo notificado: KEMA Quality B.V., No 0344. Utrechtseweg 310, 6802 ED, Arnhem, The Netherlands.

## **(GR) Δήλωση Συμμόρφωσης**

Εμείς, η Grundfos, δηλώνουμε με αποκλειστικά δική μας ευθύνη ότι τα προϊόντα NB και NBG στα οποία αναφέρεται η παρούσα δήλωση, συμμορφώνονται με τις εξής Οδηγίες του Συμβουλίου περί προσγγίσις των νομοθεσιών των κρατών μελών της ΕΕ:

- Οδηγία για μηχανήματα (2006/42/EC).  
Πρότυπα που χρησιμοποιήθηκαν: EN 809: 1998, EN 60204-1: 2006.
- Οδηγία ATEX (94/9/EC) (εφαρμόζεται μόνο σε προϊόντα με το σήμα ATEX στην πινακίδα τους).  
Πρότυπα που χρησιμοποιήθηκαν: EN 13463-1: 2001, EN 13463-5: 2003.  
(Περιλαμβάνονται δήλωση συμμόρφωσης και οδηγίες εγκατάστασης και λειτουργίας του κινητήρα.)  
Σώμα που διατηρεί σχετικό τεχνικό φάκελο: KEMA Quality B.V., No 0344. Utrechtseweg 310, 6802 ED, Arnhem, The Netherlands.

## **(S) Försäkran om överensstämmelse**

Vi, Grundfos, försäkrar under ansvar att produkterna NB och NBG, som omfattas av denna försäkran, är i överensstämmelse med rådets direktiv om inbördes närmande till EU-medlemsstaternas lagstiftning, avseende:

- Maskindirektivet (2006/42/EG).  
Tillämpade standarder: EN 809: 1998, EN 60204-1: 2006.
- ATEX-direktivet (94/9/EG) (endast för produkter med ATEX-märkning på typskylten).  
Tillämpade standarder: EN 13463-1: 2001, EN 13463-5: 2003.  
(Försäkran om överensstämmelse samt monterings- och driftsinstruktion medföljer medlevererad motor.)  
Tillsynsmyndighet i besittning av kopia av teknisk fil: KEMA Quality B.V., No 0344. Utrechtseweg 310, 6802 ED, Arnhem, The Netherlands.

## **(D) Konformitätserklärung**

Wir, Grundfos, erklären in alleiniger Verantwortung, dass die Produkte NB und NBG, auf die sich diese Erklärung bezieht, mit den folgenden Richtlinien des Rates zur Angleichung der Rechtsvorschriften der EU-Mitgliedsstaaten übereinstimmen:

- Maschinenrichtlinie (2006/42/EG).  
Normen, die verwendet wurden: EN 809: 1998, EN 60204-1: 2006.
- ATEX-Richtlinie (94/9/EG)  
(Gilt nur für Produkte mit der ATEX-Kennzeichnung auf dem Leistungsschild).  
Normen, die verwendet wurden: EN 13463-1: 2001, EN 13463-5: 2003.  
(Die Konformitätsbescheinigung und Bedienungsanleitung vom Motor sind beigefügt.)  
Benannte Stelle, bei der die technischen Unterlagen hinterlegt sind: KEMA Quality B.V., No 0344. Utrechtseweg 310, 6802 ED, Arnhem, The Netherlands.

## **(I) Dichiarazione di Conformità**

Grundfos dichiara sotto la sua esclusiva responsabilità che i prodotti NB e NBG, ai quali si riferisce questa dichiarazione, sono conformi alle seguenti direttive del Consiglio riguardanti il riavvicinamento delle legislazioni degli Stati membri CE:

- Direttiva Macchine (2006/42/CE).  
Norme applicate: EN 809: 1998, EN 60204-1: 2006.
- Direttiva ATEX (94/9/CE) (si applica solo ai prodotti che riportano la sigla ATEX sull'etichetta).  
Norme applicate: EN 13463-1: 2001, EN 13463-5: 2003.  
(In allegato la dichiarazione di conformità e il manuale di installazione e funzionamento.)  
Organismo notificato in possesso di copia del fascicolo tecnico: KEMA Quality B.V., No 0344. Utrechtseweg 310, 6802 ED, Arnhem, The Netherlands.

## **(P) Declaração de Conformidade**

A Grundfos declara sob sua única responsabilidade que os produtos NB e NBG, aos quais diz respeito esta declaração, estão em conformidade com as seguintes Directivas do Conselho sobre a aproximação das legislações dos Estados Membros da CE:

- Directiva Máquinas (2006/42/CE).  
Normas utilizadas: EN 809: 1998, EN 60204-1: 2006.
- Directiva ATEX (94/9/CE) (apenas aplicável a produtos com a inscrição ATEX gravada na chapa de características).  
Normas utilizadas: EN 13463-1: 2001, EN 13463-5: 2003.  
(Em anexo encontra a Declaração de conformidade e instruções de instalação e funcionamento do motor.)  
Cópia notificada do ficheiro técnico: KEMA Quality B.V., No 0344. Utrechtseweg 310, 6802 ED, Arnhem, The Netherlands.

## **(NL) Overeenkomstigheidsverklaring**

Wij, Grundfos, verklaren geheel onder eigen verantwoordelijkheid dat de producten NB en NBG waarop deze verklaring betrekking heeft, in overeenstemming zijn met de Richtlijnen van de Raad in zake de onderlinge aanpassing van de wetgeving van de EG Lidstaten betreffende:

- Machine Richtlijn (2006/42/EC).  
Gebruikte normen: EN 809: 1998, EN 60204-1: 2006.
- ATEX Richtlijn (94/9/EC) (alleen van toepassing voor producten met de ATEX markering op de typeplaat).  
Gebruikte normen: EN 13463-1: 2001, EN 13463-5: 2003.  
(Overeenkomstigheidsverklaring is ingesloten in de bedienings- en installatievoorschriften van de motor.)  
Instantie die een kopie van het technische bestand heeft: KEMA Quality B.V., No 0344. Utrechtseweg 310, 6802 ED, Arnhem, The Netherlands.

## **(FIN) Vaatimustenmukaisuusvakuutus**

Me, Grundfos, vakuutamme omalla vastuullamme, että tuotteet NB ja NBG, joita tämä vakuutus koskee, ovat EY:n jäsenvaltioiden lainsäädännön yhdenmukaistamiseen tähtäävien Euroopan neuvoston direktiivien vaatimusten mukaisia seuraavasti:

- Konedirektiivi (2006/42/EY).  
Sovellettavat standardit: EN 809: 1998, EN 60204-1: 2006.
- ATEX-direktiivi (94/9/EY) (soveltuu vain tuotteisiin, joissa on ATEX-merkintä arvokilvessä).  
Sovellettavat standardit: EN 13463-1: 2001, EN 13463-5: 2003.  
(Moottorin vaatimustenmukaisuusvakuutus ja käyttöohjeet sisältyvät toimitukseen.)  
Ilmoitettu laitos, joka ylläpitää teknistä tiedostoa: KEMA Quality B.V., No 0344. Utrechtseweg 310, 6802 ED, Arnhem, The Netherlands.

## **DK** Overensstemmelseserklæring

Vi, Grundfos, erklærer under ansvar at produktet NB og NBG som denne erklæring omhandler, er i overensstemmelse med disse af Rådets direktiver om indbyrdes tilnærmelse til EF-medlemsstaternes lovgivning:

- Maskindirektivet (2006/42/EF).  
Anvendte standarder: EN 809: 1998, EN 60204-1: 2006.
- ATEX-direktivet (94/9/EF) (gælder kun for produkter med ATEX-mærkning på typeskiltet).  
Anvendte standarder: EN 13463-1: 2001, EN 13463-5: 2003.  
(Motorens overensstemmelseserklæring og monterings- og driftsinstruktion er vedlagt).  
Bemyndiget organ som opbevarer en kopi af den tekniske fil: KEMA Quality B.V., No 0344. Utrechtseweg 310, 6802 ED, Arnhem, The Netherlands.

## **RU** Декларация о соответствии

Мы, компания Grundfos, со всей ответственностью заявляем, что изделия NB и NBG, к которым относится настоящая декларация, соответствуют следующим Директивам Совета Евросоюза об унификации законодательных предписаний стран-членов ЕС:

- Механические устройства (2006/42/ЕС).  
Применявшиеся стандарты: Евростандарт EN 809: 1998, EN 60204-1: 2006.
- Директива ATEX (94/9/ЕС) (действительно только для изделий с маркировкой ATEX на фирменной табличке с техническими данными).  
Применявшиеся стандарты: EN 13463-1: 2001, EN 13463-5: 2003.  
(Заявление о соответствии и руководство по монтажу и эксплуатации электродвигателя прилагаются.)  
Нотификационный орган, владеющий экземпляром технической документации: KEMA Quality B.V., No 0344. Utrechtseweg 310, 6802 ED, Arnhem, The Netherlands.

## **SI** Izjava o skladnosti

V Grundfosu s polno odgovornostjo izjavljamo, da so naši izdelki NB in NBG, na katere se ta izjava nanaša, v skladu z naslednjimi direktivami Sveta o približevanju zakonodaje za izenačevanje pravnih predpisov držav članic ES:

- Direktiva o strojih (2006/42/ES).  
Uporabljeni normi: EN 809: 1998, EN 60204-1: 2006.
- ATEX direktiva (94/9/ES) (velja samo za izdelke z oznako ATEX na tipski ploščici).  
Uporabljeni normi: EN 13463-1: 2001, EN 13463-5: 2003.  
(Izjava o ustreznosti ter navodila za montažo in obratovanje motorja sta priložena.)  
Priglašeni organ, ki drži kopijo tehnične datoteke: KEMA Quality B.V., No 0344. Utrechtseweg 310, 6802 ED, Arnhem, The Netherlands.

## **SER** Deklaracija o konformitetu

Mi, Grundfos, izjavljujemo pod vlastitom odgovornostjo da je proizvod NB i NBG, na koji se ova izjava odnosi, u skladu sa direktivama Saveta za usklađivanje zakona država članica EU:

- Direktiva za mašine (2006/42/EC).  
Korišćeni standardi: EN 809: 1998, EN 60204-1: 2006.
- ATEX direktiva (94/9/EC) (odnosi se samo na proizvode sa natpisom ATEX na natpisnoj pločici).  
Korišćeni standardi: EN 13463-1: 2001, EN 13463-5: 2003.  
(Deklaracija konformiteta i uputstva za instalaciju i rad motora su priloženi.)  
Nadležno telo ima kopiju tehničkih podataka: KEMA Quality B.V., No 0344. Utrechtseweg 310, 6802 ED, Arnhem, The Netherlands.

## **BG** Декларация за съответствие

Ние, фирма Grundfos, заявяваме с пълна отговорност, че продуктите NB и NBG, за които се отнася настоящата декларация, отговарят на следните указания на Съвета за уеднавяване на правните разпоредби на държавите членки на ЕС:

- Директива за машините (2006/42/ЕС).  
Приложени стандарти: EN 809: 1998, EN 60204-1: 2006.
- ATEX директива (94/9/ЕС) (отнася се само за продукти със символа ATEX върху табелата с данни).  
Приложени стандарти: EN 13463-1: 2001, EN 13463-5: 2003.  
(Приложени са също и Декларацията за съответствие и инструкциите за монтаж и експлоатация на двигателя.)  
Оторизирана организация притежаваща копие от техническия файл: KEMA Quality B.V., No 0344. Utrechtseweg 310, 6802 ED, Arnhem, The Netherlands.

## **PL** Deklaracja zgodności

My, Grundfos, oświadczamy z pełną odpowiedzialnością, że nasze wyroby NB oraz NBG, których deklaracja niniejsza dotyczy, są zgodne z następującymi wytycznymi Rady d/s ujednolicenia przepisów prawnych krajów członkowskich WE:

- Dyrektywa Maszynowa (2006/42/WE).  
Zastosowane normy: EN 809: 1998, EN 60204-1: 2006.
- Dyrektywa ATEX (94/9/WE) (dotyczy tylko wyrobów ze znakiem ATEX na tabliczce znamionowej).  
Zastosowane normy: EN 13463-1: 2001, EN 13463-5: 2003.  
(Deklaracja zgodności oraz instrukcja obsługi i eksploatacji silnika są załączone.)  
Kopie pliku technicznego posiada odpowiednia jednostka: KEMA Quality B.V., No 0344. Utrechtseweg 310, 6802 ED, Arnhem, The Netherlands.

## **H** Konformitási nyilatkozat

Mi, a Grundfos, egyedüli felelősséggel kijelentjük, hogy a NB és NBG termékek, amelyekre jelen nyilatkozik vonatkozik, megfelelnek az Európai Unió tagállamainak jogi irányelveit összehangoló tanács alábbi előírásainak:

- Gépek (2006/42/EK).  
Alkalmazott szabványok: EN 809: 1998, EN 60204-1: 2006.
- ATEX Direktíva (94/9/EK) (csak az ATEX jelzéssel ellátott termékekre vonatkozik).  
Alkalmazott szabványok: EN 13463-1: 2001, EN 13463-5: 2003.  
(A motor kezelési utasítása és megfelelőségi nyilatkozata mellékelve.)  
Minősítő szervezet technikai azonosítója: KEMA Quality B.V., No 0344. Utrechtseweg 310, 6802 ED, Arnhem, The Netherlands.

## **HR** Izjava o usklađenosti

Mi, Grundfos, izjavljujemo pod vlastitom odgovornostjo da je proizvod NB i NBG, na koji se ova izjava odnosi, u skladu s direktivama ovog Vijeća o usklađivanju zakona država članica EU:

- Direktiva za strojeve (2006/42/EZ).  
Korištene norme: EN 809: 1998, EN 60204-1: 2006.
- ATEX uredba (94/9/EZ) (vrijedi samo za proizvode s ATEX-znakom na natpisnoj pločici).  
Korištene norme: EN 13463-1: 2001, EN 13463-5: 2003.  
(Deklaracija o usklađenosti te motažne i pogonske upute priloženi su uz motor.)  
Navedeno tijelo drži kopije tehničkih podataka: KEMA Quality B.V., No 0344. Utrechtseweg 310, 6802 ED, Arnhem, The Netherlands.

## **RO** Declarație de conformitate

Noi, Grundfos, declarăm pe propria răspundere că produsele NB și NBG, la care se referă această declarație, sunt în conformitate cu aceste Directive de Consiliu asupra armonizării legilor Statelor Membre CE:

- Directiva Utilaje (2006/42/CE).  
Standarde utilizate: EN 809: 1998, EN 60204-1: 2006.
- Directiva ATEX (94/9/EC) (se aplică numai la produsele cu marca ATEX pe plăcuța de înmatriculare).  
Standarde utilizate: EN 13463-1: 2001, EN 13463-5: 2003.  
(Declarația de conformitate și instrucțiunile de instalare și operare ale motorului sunt incluse.)  
Organismul notificat deținător al documentului tehnic: KEMA Quality B.V., No 0344. Utrechtseweg 310, 6802 ED, Arnhem, The Netherlands.

## **CZ** Prohlášení o shodě

My firma Grundfos prohlašujeme na svou plnou odpovědnost, že výrobky NB a NBG, na něž se toto prohlášení vztahuje, jsou v souladu s ustanoveními směrnice Rady pro sblížení právních předpisů členských států Evropského společenství v oblastech:

- Směrnice pro strojní zařízení (2006/42/ES).  
Použité normy: EN 809: 1998, EN 60204-1: 2006.
- Směrnice pro ATEX (94/9/ES) (týká se pouze výrobků nesoucích na typovém štítku značku ATEX).  
Použité normy: EN 13463-1: 2001, EN 13463-5: 2003.  
(Prohlášení o konformitě a instalační a provozní předpisy motoru jsou přiloženy.)  
Úřední orgán spravující kopii technické složky: KEMA Quality B.V., No 0344. Utrechtseweg 310, 6802 ED, Arnhem, The Netherlands.

### SK Prehlásenie o konformite

My firma Grundfos prehlasujeme na svoju plnú zodpovednosť, že výrobky NB a NBG, na ktoré sa toto prehlásenie vzťahuje, sú v súlade s ustanovením smernice Rady pre zblíženie právnych predpisov členských štátov Európskeho spoločenstva v oblastiach:

- Smernica pre strojové zariadenie (2006/42/EC).  
Použité normy: EN 809: 1998, EN 60204-1: 2006.
- Smernica pre ATEX (94/9/EC) (týka sa iba výrobkov nesúcich na typovom štítku značku ATEX).  
Použité normy: EN 13463-1: 2001, EN 13463-5: 2003.  
(Prehlásenie o konformite a montážny a prevádzkový návod motora sú priložené.)  
Úradný orgán spravujúci kópiu technickej zložky: KEMA Quality B.V., No 0344. Utrechtseweg 310, 6802 ED, Arnhem, The Netherlands.

### TR Uygunluk Bildirgesi

Grundfos olarak bu beyannameye konu olan NB ve NBG ürünlerinin, AB Üyesi Ülkelerin kanunlarını birbirine yaklaştırma üzerine Konsey Direktifleriyle uyumlu olduğunun yalnızca bizim sorumluluğumuz altında olduğunu beyan ederiz:

- Makineler Yönetmeliği (2006/42/EC).  
Kullanılan standartlar: EN 809: 1998, EN 60204-1: 2006.
- ATEX Yönergesi (94/9/EC) (sadece bilgi etiketinde ATEX işareti bulunan ürünlere uygulanmaktadır).  
Kullanılan standartlar: EN 13463-1: 2001, EN 13463-5: 2003.  
(Motorun uygunluk beyannamesi ve montaj ve kullanım bilgileri arkaya eklenmiştir.)  
Onayı veren kuruluş: KEMA Quality B.V., No 0344. Utrechtseweg 310, 6802 ED, Arnhem, The Netherlands.

### EE Vastavusdeklaratsioon

Meie, Grundfos, deklareerime enda ainuvastutustel, et tooted NB ja NBG, mille kohta käesolev juhend käib, on vastavuses EÜ Nõukogu direktiividega EMÜ liikmesriikide seaduste ühitamise kohta, mis käsitlevad:

- Masinate ohutus (2006/42/EC).  
Kasutatud standardid: EN 809: 1998, EN 60204-1: 2006.
- ATEX direktiiv (94/9/EC) (ainult toodete korral, mille sildikul on ATEX tähistus).  
Kasutatud standardid: EN 13463-1: 2001, EN 13463-5: 2003.  
(Mootori vastavuse deklaratsioon ning paigaldus- ja kasutusjuhend on lisatud.)  
Ettevõtte, kus asub tehnilise faili koopia: KEMA Quality B.V., No 0344. Utrechtseweg 310, 6802 ED, Arnhem, The Netherlands.

### LT Atitikties deklaracija

Mes, Grundfos, su visa atsakomybe pareiškiame, kad gaminiai NB ir NBG, kuriems skirta ši deklaracija, atitinka šias Tarybos Direktyvas dėl Europos Ekonominės Bendrijos šalių narių įstatymų suderinimo:

- Mašinų direktyva (2006/42/EB).  
Taikomi standartai: EN 809: 1998, EN 60204-1: 2006.
- ATEX direktyva (94/9/EB) (galioja tik produktams, kurių vardinėje plokštelėje yra ATEX ženklinimas).  
Taikomi standartai: EN 13463-1: 2001, EN 13463-5: 2003.  
(Variklio atitikties deklaracija bei įrengimo ir naudojimo instrukcija pridedama.)  
Paskelbtoji įstaiga, turinti techninės bylos kopiją: KEMA Quality B.V., No 0344. Utrechtseweg 310, 6802 ED, Arnhem, The Netherlands.

### LV Paziņojums par atbilstību prasībām

Sabiedrība GRUNDFOS ar pilnu atbildību dara zināmu, ka produkti NB un NBG, uz kuriem attiecas šis paziņojums, atbilst šādām Padomes direktīvām par tuvināšanas EK dalībvalstu likumdošanas normām:


- Mašīnbūves direktīva (2006/42/EK).  
Piemērotie standarti: EN 809: 1998, EN 60204-1: 2006.
- ATEX direktīva (94/9/EK) (attiecas tikai uz izstrādājumiem ar ATEX marķējumu pasēs datu plāksnītē).  
Piemērotie standarti: EN 13463-1: 2001, EN 13463-5: 2003.  
(Ir pievienotas motora uzstādīšanas un lietošanas instrukcijas un paziņojums par atbilstību prasībām.)  
Pilnvarotā iestāde, kurai ir nodots glabāšanai tehniskās dokumentācijas eksemplārs: KEMA Quality B.V., No 0344. Utrechtseweg 310, 6802 ED, Arnhem, The Netherlands.

### UA Свідчення про відповідність вимогам

Компанія Grundfos заявляє про свою виключну відповідальність за те, що продукти NB та NBG, на які поширюється дана декларація, відповідають таким рекомендаціям Ради з уніфікації правових норм країн - членів ЄС:

- Механічні прилади (2006/42/EC).  
Стандарти, що застосовувалися: Євростандарт EN 809: 1998, EN 60204-1: 2006.
- АТЕХ Директива (94/9/EC) (тільки для насосів/продуктів з відміткою АТЕХ на заводській таблиці з технічними даними (шильдiku)).  
Стандарти, що застосовувалися: Євростандарт EN 13463-1: 2001, EN 13463-5: 2003.  
(Декларація відповідності і установки і операційних інструкцій двигуна прикладена.)  
Копія технічної документації зберігається в уповноваженій організації: KEMA Quality B.V., No 0344. Utrechtseweg 310, 6802 ED, Arnhem, The Netherlands.

Bjerringbro, 15th December 2009



Svend Aage Kaae  
Technical Director

# NB, NBG

<b>Installation and operating instructions</b>	6	<b>GB</b>
<b>Montage- und Betriebsanleitung</b>	27	<b>D</b>
<b>Notice d'installation et de fonctionnement</b>	49	<b>F</b>
<b>Istruzioni di installazione e funzionamento</b>	71	<b>I</b>
<b>Instrucciones de instalación y funcionamiento</b>	93	<b>E</b>
<b>Instruções de instalação e funcionamento</b>	115	<b>P</b>
<b>Οδηγίες εγκατάστασης και λειτουργίας</b>	137	<b>GR</b>
<b>Installatie- en bedieningsinstructies</b>	160	<b>NL</b>
<b>Monterings- och driftsinstruktion</b>	182	<b>S</b>
<b>Asennus- ja käyttöohjeet</b>	204	<b>FIN</b>
<b>Monterings- og driftsinstruktion</b>	226	<b>DK</b>
<b>Instrukcja montażu i eksploatacji</b>	248	<b>PL</b>
<b>Руководство по монтажу и эксплуатации</b>	270	<b>RU</b>
<b>Szerelési és üzemeltetési utasítás</b>	294	<b>H</b>
<b>Navodila za montažo in obratovanje</b>	316	<b>SI</b>
<b>Montažne i pogonske upute</b>	338	<b>HR</b>
<b>Uputstvo za instalaciju i rad</b>	359	<b>SER</b>
<b>Instrucțiuni de instalare și utilizare</b>	381	<b>RO</b>
<b>Упътване за монтаж и експлоатация</b>	403	<b>BG</b>
<b>Montážní a provozní návod</b>	427	<b>CZ</b>
<b>Návod na montáž a prevádzku</b>	449	<b>SK</b>
<b>Montaj ve kullanım kılavuzu</b>	471	<b>TR</b>
<b>Paigaldus- ja kasutusjuhend</b>	494	<b>EE</b>
<b>Įrengimo ir naudojimo instrukcija</b>	516	<b>LT</b>
<b>Uzstādīšanas un ekspluatācijas instrukcija</b>	538	<b>LV</b>
<b>Інструкції з монтажу та експлуатації</b>	560	<b>UA</b>

## CONTENTS

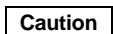
1. **Symbols used in this document - 6**
2. **General information - 6**
3. **Delivery and handling - 7**
  - 3.1 Delivery - 7
  - 3.2 Handling - 7
4. **Type keys - 8**
  - 4.1 Type NB - 8
  - 4.2 Type NBG - 8
  - 4.3 Impeller diameter - 10
  - 4.4 Pumped liquids - 10
5. **Technical data - 10**
  - 5.1 Ambient temperature - 10
  - 5.2 Liquid temperature - 10
  - 5.3 Operating pressure - 10
  - 5.4 Min. inlet pressure - 10
  - 5.5 Maximum inlet pressure - 10
  - 5.6 Minimum flow rate - 10
  - 5.7 Maximum flow rate - 10
  - 5.8 Electrical data - 10
  - 5.9 Weight - 10
  - 5.10 Sound level - 10
  - 5.11 Pump speed relative to material and size - 10
6. **Pump without motor - 11**
  - 6.1 Motor without feet - 11
  - 6.2 Motor with feet - 13
7. **Mechanical installation - 15**
  - 7.1 Preparations before installation - 15
  - 7.2 Pump location - 15
  - 7.3 Connection - 15
  - 7.4 Foundation of NB, NBG pump without base frame - 16
  - 7.5 Foundation of NB, NBG pump with base frame - 16
  - 7.6 Pipework - 20
  - 7.7 Vibration dampening - 20
  - 7.8 Expansion joints - 21
  - 7.9 Measuring instruments - 21
8. **Flange forces and torques - 22**
9. **Electrical connection - 23**
  - 9.1 Motor protection - 23
  - 9.2 Frequency converter operation - 23
10. **Start-up - 24**
  - 10.1 General information - 24
  - 10.2 Priming - 24
  - 10.3 Checking the direction of rotation - 24
  - 10.4 Start-up - 24
  - 10.5 Start/stop - 24
11. **Maintenance - 25**
  - 11.1 Pump - 25
  - 11.2 Mechanical shaft seals - 25
  - 11.3 Motor - 25
  - 11.4 Lubrication - 25
12. **Periods of inactivity and frost protection - 25**
13. **Service - 25**
  - 13.1 Service kits - 25
14. **Calculation of minimum inlet pressure - 25**
15. **Fault finding chart - 26**
16. **Disposal - 26**

## 1. Symbols used in this document

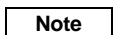


### Warning

*If these safety instructions are not observed, it may result in personal injury!*



*If these safety instructions are not observed, it may result in malfunction or damage to the equipment!*



*Notes or instructions that make the job easier and ensure safe operation.*

## 2. General information

### Pump type and model are stated on the pump nameplate

The pumps are fitted with Grundfos motors, type MG or MMG. If the pump is fitted with a motor make other than Grundfos, please note that the motor data may differ from the data stated in this booklet. This may also influence the pump performance.



### Warning

*Prior to installation, read these installation and operating instructions. Installation and operation must comply with local regulations and accepted codes of good practice.*

### 3. Delivery and handling

#### 3.1 Delivery

The pumps are tested 100 % before leaving the factory. The test includes a function test where the pump performance is measured to ensure that the pump meets requirements of relevant standards. Test certificates are available from Grundfos. The pumps are delivered from the factory in a carton with a wooden bottom designed for transport by equipment such as a forklift truck.

Pump motors as from 4 kW are supplied with lifting eyes.

The following is supplied:	Unit without motor and pump	Unit without motor	Complete unit
Pump		●	●
Base frame	●		●
Electric motor, mounting designation B 5 or B 35			●
Installation and operating instructions		●	●

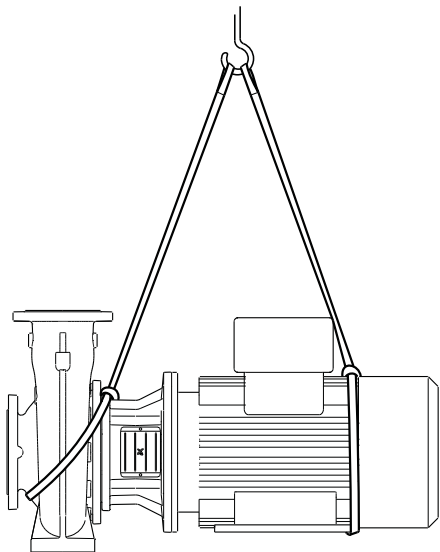
#### 3.2 Handling



**Warning**

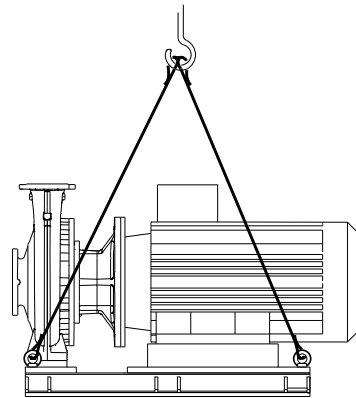
*Pump motors as from 4 kW are supplied with lifting eyes which must not be used for lifting the entire pump unit. See fig. 2.*

Pumps fitted with motors should be lifted by means of nylon straps and shackles, if required. See fig. 1.

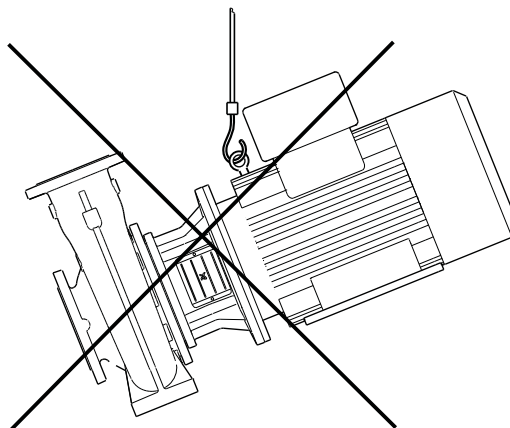


**Fig. 1** Correct lifting of pump without base frame

TM03 3973 1306



**Fig. 2** Correct lifting of pump with base frame



**Fig. 3** Incorrect lifting of pump

TM04 5179 2809

TM03 3972 1306

## 4. Type keys

### 4.1 Type NB

	NB	32	-125	.1	/142	A	-F	-A	-BAQE
Type range NB NBE									
Nominal diameter of discharge port (DN)									
Nominal impeller diameter [mm]									
Reduced performance = .1									
Actual impeller diameter [mm]									
Code for pump version (the codes may be combined) A = Basic version B = Oversize motor C = Without motor D = Pump housing with feet E = With ATEX approval, certificate or test report F = Design with base frame X = Special version									
Code for pipe connection: F = DIN flange									
Code for materials: A = Cast iron EN-GJL-250 B = EN-GJL-250 with bronze impeller CuSn10 C = As type A + 1.4401 shaft D = As type B + 1.4401 shaft S = EN-GJL-250 with 1.4408 impeller N = 1.4408 pump housing and impeller, PTFE wear ring R = 1.4517 pump housing and impeller, PTFE wear ring P = 1.4408 pump housing, 1.4517 impeller, PTFE wear ring K = 1.4408 pump housing and impeller, 1.4517 wear ring L = 1.4517 pump housing, impeller and wear ring M = 1.4408 pump housing, 1.4517 impeller and wear ring X = Special version									
Code for shaft seal and rubber pump parts									

Examples of combined pump version codes:

- AE = Basic version with certificate or test report.
- BD = With oversize motor and pump housing with feet.
- CE = Without motor and with certificate and/or test report.

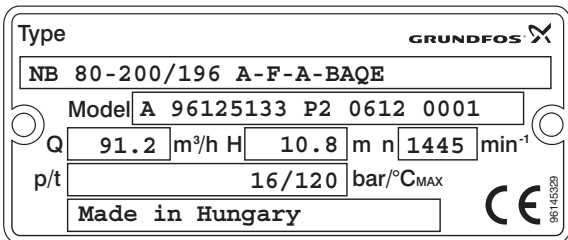


Fig. 4 Example of nameplate for NB

The example shows an NB 80-200 with 196 mm impeller, made of cast iron with BAQE shaft seal and a 4-pole motor.

### 4.2 Type NBG

	NBG	50	-32	-125	.1	/142	A	-F	-A	-BAQE
Type range NBG NBGE										
Nominal diameter of suction port (DN)										
Nominal diameter of discharge port (DN)										
Nominal impeller diameter [mm]										
Reduced performance = .1										
Actual impeller diameter [mm]										
Code for pump version (the codes may be combined) A = Basic version B = Oversize or double-oversize motor C = Without motor D = Pump housing with feet E = With ATEX approval, certificate or test report F = Design with base frame X = Special version										
Code for pipe connection: F = DIN flange E = Table E flange										
Code for materials: A = Cast iron EN-GJL-250 B = EN-GJL-250 with bronze impeller CuSn10 C = As type A + 1.4401 shaft D = As type B + 1.4401 shaft S = EN-GJL-250 with 1.4408 impeller N = 1.4408 pump housing and impeller, PTFE wear ring R = 1.4517 pump housing and impeller, PTFE wear ring P = 1.4408 pump housing, 1.4517 impeller, PTFE wear ring K = 1.4408 pump housing and impeller, 1.4517 wear ring L = 1.4517 pump housing, impeller and wear ring M = 1.4408 pump housing, 1.4517 impeller and wear ring X = Special version										
Code for shaft seal and rubber pump parts										

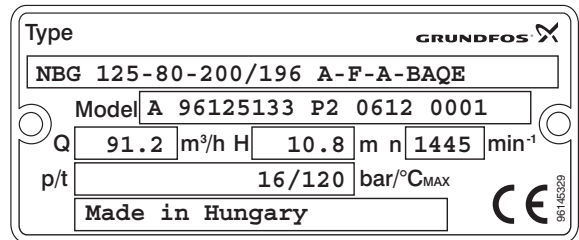


Fig. 5 Example of nameplate for NBG

The example shows an NBG 125-80-200 with 196 mm impeller, made of cast iron with BAQE shaft seal and a 4-pole motor.

TM03 4243 1906

TM03 3981 1406



## Mechanical shaft seal

Shaft seal diameter [mm]	Code	Temperature range	28, 38	48	55	60
			Maximum pressure [bar]			
Rubber bellows seal, metal-impregnated carbon/silicon carbide, EPDM	BAQE	0 °C to +120 °C	16	16	16	16
Rubber bellows seal, metal-impregnated carbon/silicon carbide, FKM	BAQV	0 °C to +90 °C	16	16	16	16
Rubber bellows seal, silicon carbide/silicon carbide, EPDM	BQQE	0 °C to +90 °C	16	16	16	16
Rubber bellows seal, silicon carbide/silicon carbide, FKM	BQQV	0 °C to +90 °C	16	16	16	16
Bellow seal, type B, with reduced seal faces, silicon carbide/silicon carbide, EPDM	GQQE	-25 °C to +90 °C	16	16*	16*	16*
Bellow seal, type B, with reduced seal faces, silicon carbide/silicon carbide, FKM	GQQV	-20 °C to +90 °C	16	16*	16*	16*
O-ring seal with fixed seal driver, silicon carbide/silicon carbide, EPDM	AQQE	0 °C to +90 °C	25	25	16	16
O-ring seal with fixed seal driver, silicon carbide/silicon carbide, FKM	AQQV	0 °C to +90 °C	25	25	16	16
O-ring seal with fixed seal driver, silicon carbide/metal-impregnated carbon, EPDM	AQAE	0 °C to +120 °C	25	25	25	25
O-ring seal with fixed seal driver, silicon carbide/metal-impregnated carbon, FKM	AQAV	0 °C to +90 °C	25	25	25	25
Rubber bellows seal, silicon carbide/synthetic resin-impregnated carbon, EPDM	BQBE	0 °C to +140 °C	16	-	-	-
O-ring seal, balanced, metal-impregnated carbon/silicon carbide, FXM	DAQF	0 °C to +140 °C	25	25	25	25
Rubber bellows seal, synthetic resin-impregnated carbon/silicon carbide, EPDM	BBQE	0 °C to +120 °C	16	16	16	16

\* -25 °C to 60 °C

**4.3 Impeller diameter**

At the customer's request, the impeller diameter may have been changed to allow the pump to match a specified duty point. This means that the actual impeller diameter differs from the standard diameters stated in sales catalogues, data sheets, etc.

The actual impeller diameter can be found on the pump nameplate.

**4.4 Pumped liquids**

Clean, thin, non-explosive liquids without solid particles or fibres. The pumped liquid must not attack the pump materials chemically.

When pumping liquids with a density and/or viscosity higher than that of water, motors with correspondingly higher outputs must be used, if required.

O-rings and the mechanical shaft seal chosen must be suitable for the liquid to be pumped.

Special shaft seals may be required if the pump is used for pumping treated water at temperatures above 80 °C containing additives to prevent system corrosion, calcareous deposits, etc., for instance in heating and ventilating systems.

Another type of shaft seal may also be required for the pumping of glycol-containing liquids.

For heating systems, the water quality should meet VDI 2035. Contact Grundfos for further information.

**5. Technical data**

**5.1 Ambient temperature**

The ambient temperature and the installation altitude are important factors for the motor life, as they affect the life of the bearings and insulation system.

Maximum ambient temperature:

- EFF2 motors: +40 °C.
- EFF1 motors: +60 °C.

If the ambient temperature exceeds +40 °C (+60 °C), or the motor is installed more than 1000 m (3500 m) above sea level, the motor must not be fully loaded due to the low density and consequently low cooling effect of the air. In such cases, it may be necessary to use a motor with a higher output.

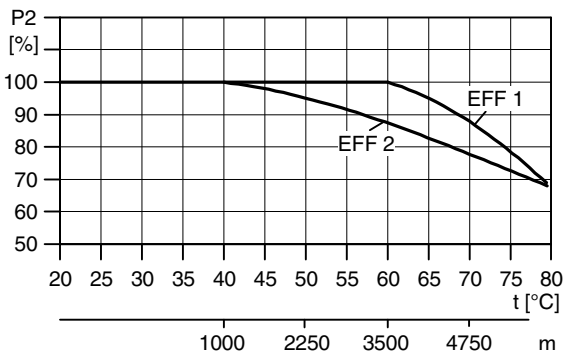


Fig. 6 Motor P2 in relation to temperature/altitude

**5.2 Liquid temperature**

-25 °C to +140 °C.

The maximum liquid temperature is stated on the pump nameplate. It depends on the shaft seal chosen.

For pump housing of cast iron EN-GJL-250 local regulations may not allow liquid temperatures above +120 °C.

**5.3 Operating pressure**

The maximum operating pressure is stated on the nameplate.

**NB:**

Maximum 1.6 MPa (16 bar).

DN 200: 1 MPa (10 bar).

**NBG:**

Maximum 1.6 MPa (16 bar).

**5.4 Min. inlet pressure**

According to the NPSH curve of the pump (see page 599) + a safety margin of minimum 0.5 m head.

The procedure for the calculation of the minimum inlet pressure is shown in 14. Calculation of minimum inlet pressure.

**5.5 Maximum inlet pressure**

The actual inlet pressure + pressure when the pump is running against a closed valve must always be lower than the maximum operating pressure.

**5.6 Minimum flow rate**

The minimum flow rate must be at least 10 % of the maximum flow rate. The flow rate and head are stated on the pump nameplate.

**5.7 Maximum flow rate**

The maximum flow rate must not exceed the values stated for the individual pump on page 585, as otherwise there is a risk of for instance cavitation and overload.

**5.8 Electrical data**

See the motor nameplate.

**5.9 Weight**

See label on the packing.

**5.10 Sound level**

See table on page 583.

The values stated are maximum values, including the upper tolerance of 3 dB according to ISO 4871.

**5.11 Pump speed relative to material and size**

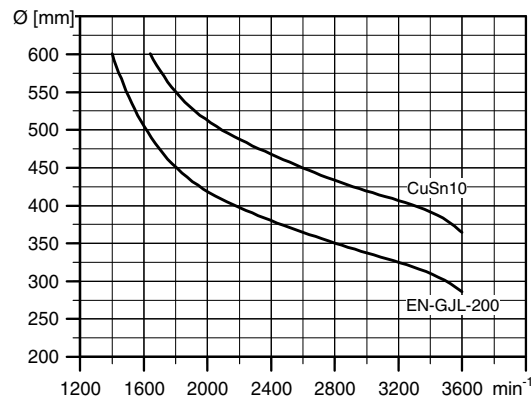


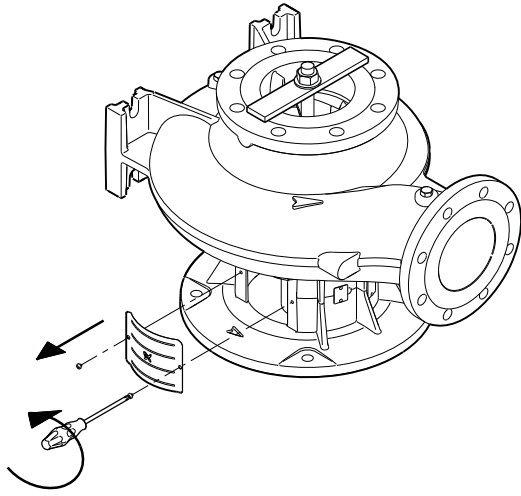
Fig. 7 Maximum permissible speed

For stainless steel pumps (1.4408/1.4517) or cast iron pumps with stainless steel impellers there is no limit in the range shown.

## 6. Pump without motor

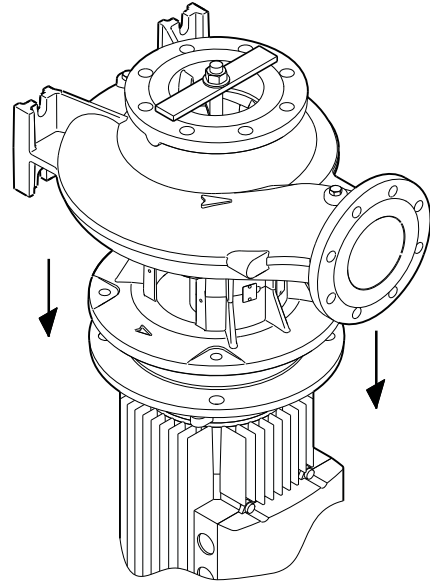
### 6.1 Motor without feet

NB and NBG pumps are available without motor. The pumps are supplied as complete pumps with a transport bracket protecting the shaft seal during transport. When you mount the motor, follow the instructions shown in these drawings.



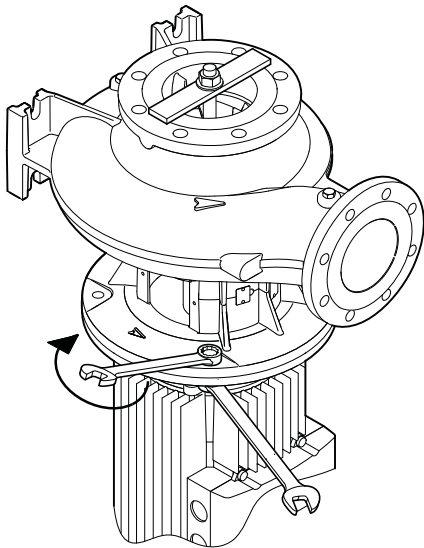
TM03 3913 1206

1. Remove the coupling guard and loosen the hexagon socket head screws in the shaft.



TM03 3906 1206

2. Place the pump on the motor.



TM03 3907 1206

3. Fit and tighten the motor screws to the correct torque. See below.

M8:  $12 \pm 2.4$  Nm

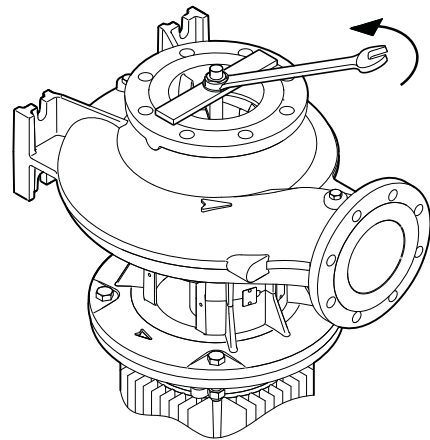
M10:  $25 \pm 5$  Nm

M12:  $40 \pm 8$  Nm

M16:  $100 \pm 20$  Nm

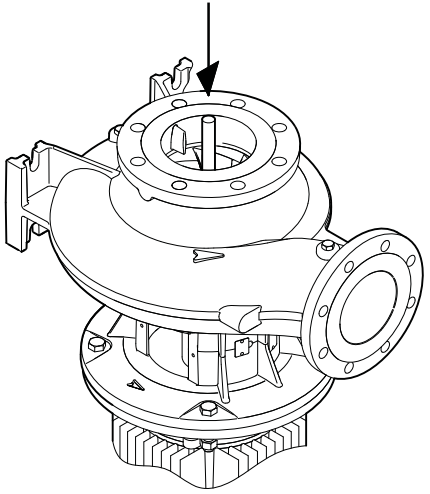
M20:  $150 \pm 30$  Nm

M24:  $200 \pm 40$  Nm



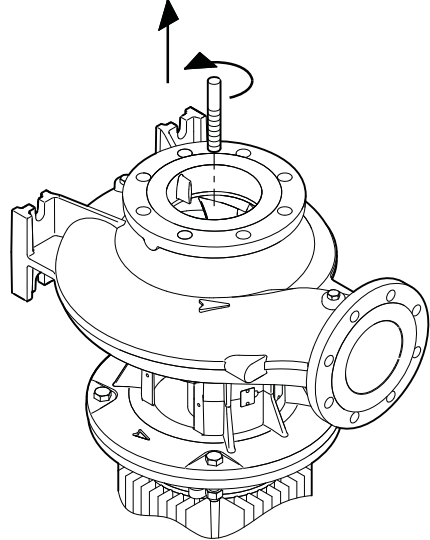
TM03 3908 1206

4. Remove the nut, washer and transport bracket.



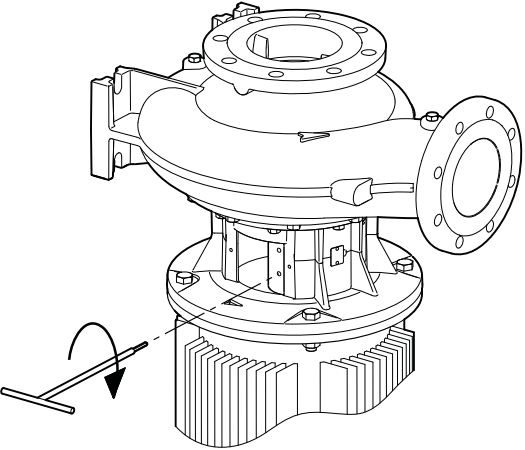
TM03 3909 1206

5. Press down the threaded pipe to ensure that the shaft is in bottom position.



TM03 3910 1206

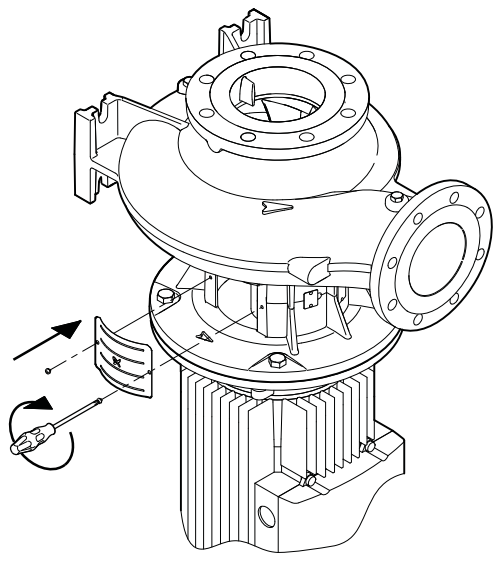
6. Remove the threaded pipe.



TM03 3911 1206

7. Apply Loctite 243 to the threads of the hexagon socket screws. Tighten the screws to the correct torque. See below.

- M5:  $6 \pm 2$  Nm
- M6:  $8 \pm 2$  Nm
- M8:  $15 \pm 3$  Nm



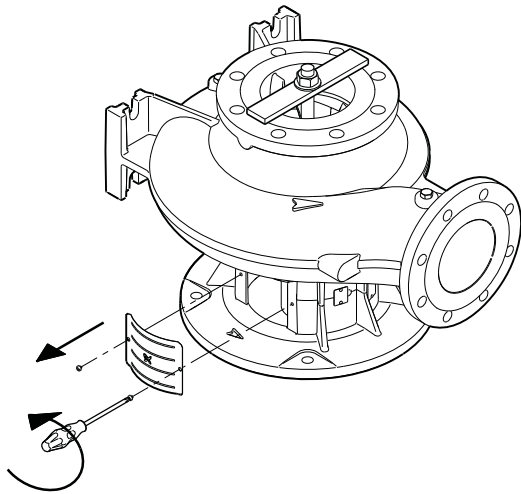
TM03 3912 1206

8. Fit the coupling guard. Tighten the screws to the correct torque. See below.

M5 x 10 mm:  $6 \pm 2$  Nm

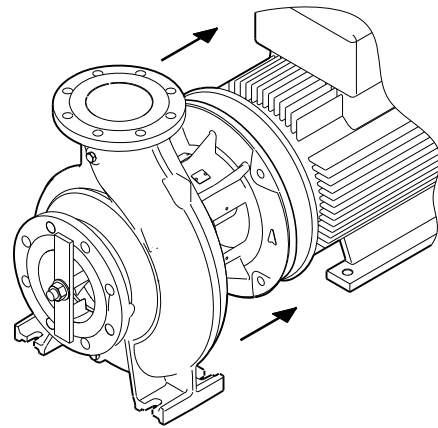
## 6.2 Motor with feet

NB and NBG pumps are available without motor. The pumps are supplied as complete pumps with a transport bracket protecting the shaft seal during transport. When you mount the motor, follow the instructions shown in these drawings.



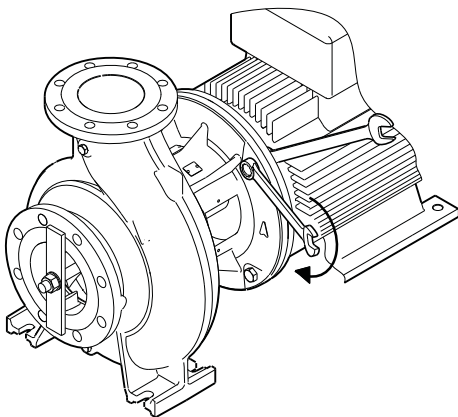
TM03 3913 1206

1. Remove the coupling guard and loosen the hexagon socket head screws in the shaft.



TM03 3905 1206

2. Place the pump at the end of the motor and push the parts together.



TM03 3914 1206

3. Fit and tighten the motor screws to the correct torque. See below.

M8:  $12 \pm 2.4$  Nm

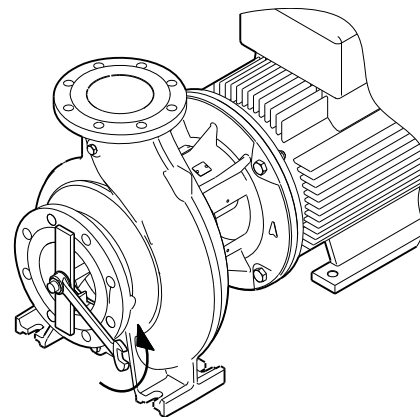
M10:  $25 \pm 5$  Nm

M12:  $40 \pm 8$  Nm

M16:  $100 \pm 20$  Nm

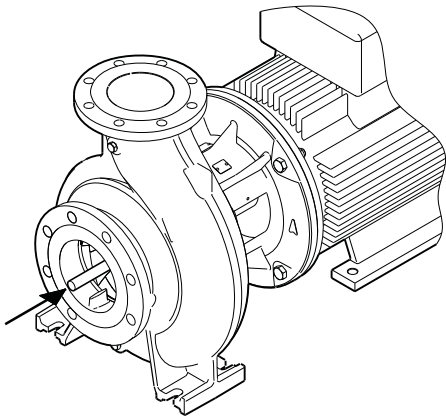
M20:  $150 \pm 30$  Nm

M24:  $200 \pm 40$  Nm



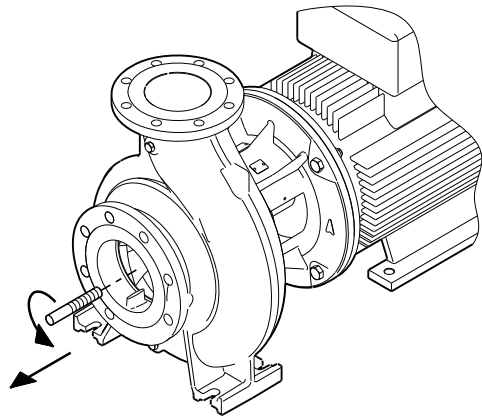
TM03 3915 1206

4. Remove the nut, washer and transport bracket.



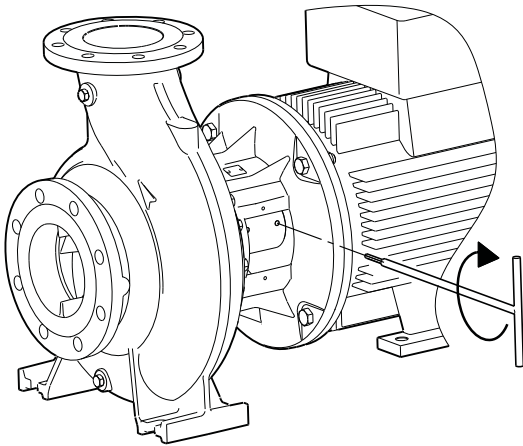
TM03 3916 1206

5. Press down the threaded pipe to ensure that the shaft is in bottom position.



TM03 3917 1206

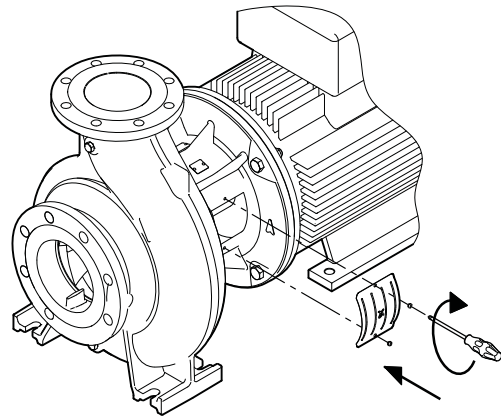
6. Remove the threaded pipe.



TM03 3918 1206

7. Apply Loctite 243 to the threads of the hexagon socket screws. Tighten the screws to the correct torque. See below.

- M5:  $6 \pm 2$  Nm
- M6:  $8 \pm 2$  Nm
- M8:  $15 \pm 3$  Nm



TM03 3919 1206

8. Fit the coupling guard. Tighten the screws to the correct torque. See below.

M5 x 10 mm:  $6 \pm 2$  Nm

## 7. Mechanical installation

### 7.1 Preparations before installation

**Caution** *It is very important to handle the equipment correctly before installation!*

The contractor must inspect the equipment on delivery and make sure that it is stored in such a way that corrosion and damage are avoided.

If more than 6 months will pass before the equipment is put into operation, it should be considered whether a suitable anti-corrosive agent should be applied to the internal pump parts.

Ensure

that the agent used does not affect the rubber parts with which it comes into contact.

that the agent can easily be removed.

To prevent water, dust, etc. from entering the pump, all openings must be kept covered until the pipes are fitted. The cost of dismantling the pump during start-up to remove a foreign object can be very high.

Mechanical shaft seals are precision components. If the mechanical shaft seal of a recently installed pump fails, this will normally happen within the first few hours of operation. The main cause of such failures is improper installation of the shaft seals and/or mishandling of the pump during installation.

During transport, the pump must be fastened securely to prevent excessive vibration and/or damage to the shaft and seal caused by dropping or striking. The pump must not be lifted by means of the shaft.

### 7.2 Pump location

The pump should be sited in a well ventilated, but frost-free location.



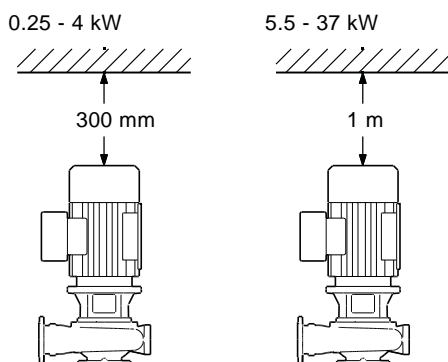
**Warning**

*When pumping hot liquids, care should be taken to ensure that persons cannot accidentally come into contact with hot surfaces.*

For inspection and repair, suitable clearances for pump or motor removal must be allowed.

#### Vertical installation

- Pumps fitted with motors up to and including 4 kW require a 300 mm clearance above the motor.
- Pumps fitted with motors of 5.5 kW and up require at least a 1 metre clearance above the motor to allow the use of lifting equipment.

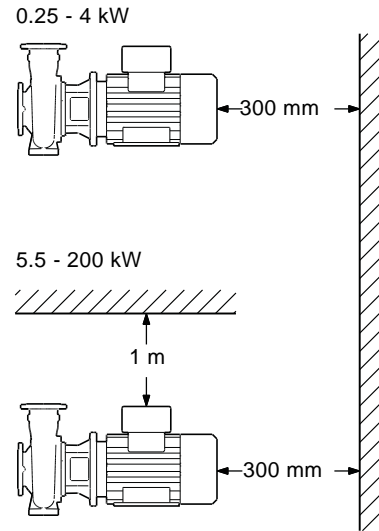


TM03 4128 1706

**Fig. 8** Clearance above the motor.

#### Horizontal installation

- Pumps fitted with motors up to and including 4 kW require a 300 mm clearance behind the motor.
- Pumps fitted with motors of 5.5 kW and up require a 300 mm clearance behind the motor and at least a 1 metre clearance above the motor to allow the use of lifting equipment.
- NB pumps with base frame must have the same clearance as pumps with motors from 5.5 to 200 kW.



TM03 4127 1706

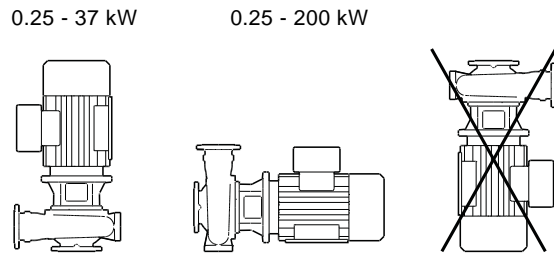
**Fig. 9** Clearance behind the motor

### 7.3 Connection

Arrows on the pump housing show the direction of flow of liquid through the pump.

The pumps can be installed with the motor/pump shaft in all positions between vertical and horizontal, but the motor must never fall below the horizontal plane.

Horizontal motors with feet must always be supported.



TM03 4126 1706

**Fig. 10** Installation positions

It is advisable to fit isolating valves on either side of the pump. It is thus not necessary to drain the system if the pump needs to be cleaned or repaired.

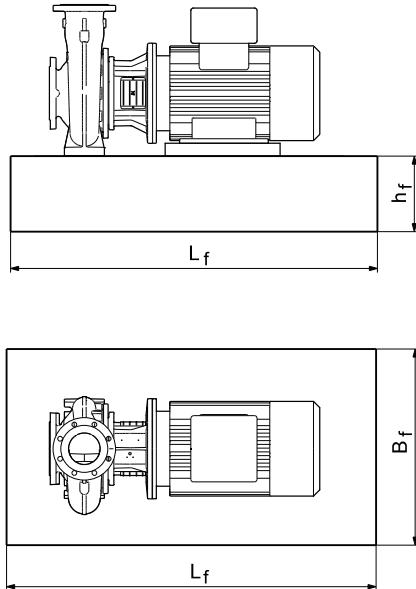
## 7.4 Foundation of NB, NBG pump without base frame

### Caution

**The foundation/installation must be carried out in accordance with the following instructions. Non-compliance may result in functional faults which will damage the pump components!**

We recommend that you install the pump on a concrete foundation which is heavy enough to provide permanent and rigid support to the entire pump. The foundation must be capable of absorbing any vibration, normal strain or shock. As a rule of thumb, the weight of the concrete foundation should be 1.5 times the weight of the pump. The concrete foundation must have an absolutely level and even surface.

Place the pump on the foundation, and fasten it. See fig. 11.



**Fig. 11** Foundation

The foundation length and width should always be 200 mm larger than the length and width of the pump. See fig. 11.

The mass of the foundation must be at least 1.5 times the total mass of the pump. The minimum height of the foundation ( $h_f$ ) can then be calculated:

$$h_f = \frac{m_{\text{pump}} \times 1.5}{L_f \times B_f \times \delta_{\text{concrete}}}$$

The density ( $\delta$ ) of concrete is usually taken as 2,200 kg/m<sup>3</sup>. In installations where noise-less operation is particularly important, a foundation with a mass up to 5 times that of the pump is recommended. See also 7.7 *Vibration dampening*.

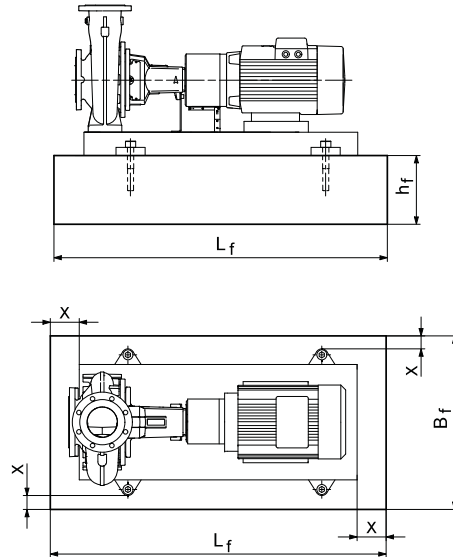
TM03 4130 1706

## 7.5 Foundation of NB, NBG pump with base frame

This section applies only to 50 Hz pumps, as base frames are not supplied for 60 Hz pumps.

We recommend that you install the pump on a plane and rigid concrete foundation which is heavy enough to provide permanent support for the entire pump. The foundation must be capable of absorbing any vibration, normal strain or shock. As a rule of thumb, the weight of the concrete foundation should be 1.5 times the pump weight.

The foundation should be 100 mm larger than the base frame on all four sides. See fig. 12.



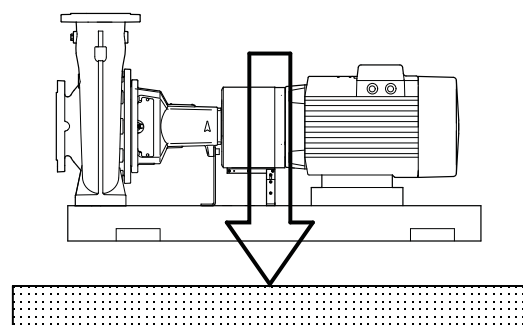
**Fig. 12** Foundation, X = min. 100 mm

The minimum height of the foundation ( $h_f$ ) can then be calculated:

$$h_f = \frac{m_{\text{pump}} \times 1.5}{L_f \times B_f \times \delta_{\text{concrete}}}$$

The density ( $\delta$ ) of concrete is usually taken as 2,200 kg/m<sup>3</sup>.

Place the pump on the foundation, and fasten it. The base frame must be supported under its entire area. See fig. 13.

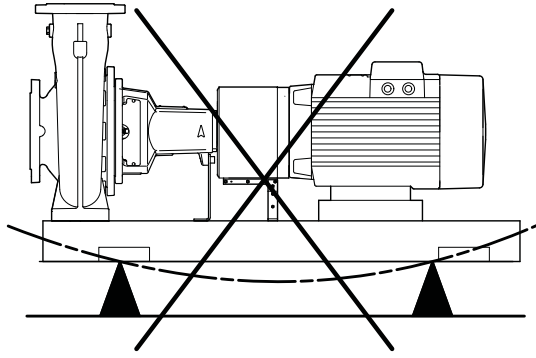


**Fig. 13** Correct foundation

TM03 3771 1206

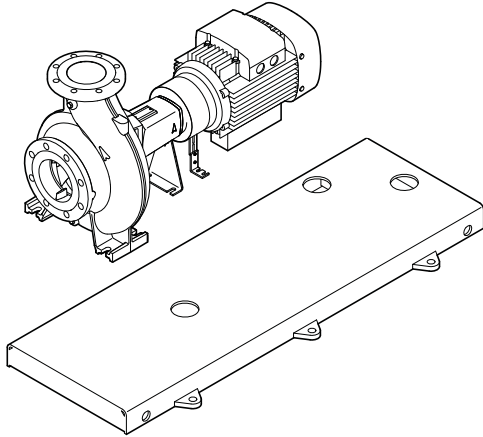
TM03 3950 1206





**Fig. 14** Incorrect foundation

TM03 4324 1206



**Fig. 15** Base frame with pouring holes

TM03 4587 2206

It is important to prepare a good foundation prior to the installation of the pump.

NB, NBG pumps with base frame are always prepared for grouting (grouting anchors welded on to the base frame).

For 2-pole NB, NBG pumps with large motors, grouting of the base frame is mandatory in order to prevent vibration energy from the rotating motor and liquid flow to evolve. See table.

kW
55
75
110
132
160
200

For pumps with motors up to and including 45 kW and for all pumps with 4- and 6-pole motors, grouting is only to be seen as an option.

#### Steps

There are three steps:

1. **Pouring of foundation**
2. **Shimming of base frame**
3. **Grouting**

#### 1: Pouring of foundation

We recommend the following procedure to ensure a good foundation.

## 1: Pouring of foundation

We recommend the following procedure to ensure a good foundation.

GB

Step	Action	Illustration
1	Use an approved, non-shrinking concrete. (Contact your concrete supplier for advice if any doubts.) Pour the foundation without interruptions to within 19 to 32 mm of the final level. Use vibrators to ensure that the concrete is evenly distributed. The top surface should be well scored and grooved before the concrete sets. This provides a bonding surface for the grout.	
2	Embed foundation bolts in the concrete. Allow enough bolt length to reach through grout, shims, lower base frame, nuts and washers.	
3	Let the foundation cure for several days before the base frame is levelled and grouted.	

TM03 0190 4707

## 2: Shimming of base frame

Step	Action	Illustration
1	Lift/jack up the base frame to the final level 19-32 mm above the concrete foundation, and support the base frame by means of blocks and shims both at the foundation bolts and midway between bolts.	
2	Level the base frame by adding or removing shims under the base frame.	
3	Tighten the foundation bolt nuts against the base frame. Make sure the piping can be aligned to the pump flanges without putting strain on pipes or flanges.	

TM04 5183 2809

TM04 0489 0708

**3: Grouting**

Grouting compensates for uneven foundation, distributes weight of unit, dampens vibrations and prevents shifting. Use an approved, non-shrinking grout. If you have questions or doubts about the grouting, please contact an expert on grouting.

Step	Action	Illustration
1	<p>Embed reinforcing steel bars into the foundation by means of 2K anchor adhesive glue.</p> <p>The number of steel bars depends on the size of the base frame, but it is advisable to distribute a minimum of 20 bars evenly over the whole area of the base frame. The free end of the steel bar should be <math>\frac{2}{3}</math> the height of the base frame to ensure a proper grouting.</p>	
2	<p>Soak top of concrete foundation thoroughly, then remove surface water.</p>	
3	<p>Ensure proper shuttering at both ends of the base frame.</p>	
4	<p>Check the levelling of the base frame again before grouting, if necessary. Pour non-shrinking grout through the openings of the base frame until the space underneath the base frame has been filled completely.</p> <p>Fill the base frame with grout up to the top level. Allow grout to dry thoroughly before attaching piping to pump (24 hours is sufficient time with approved grouting procedure).</p> <p>When the grout has thoroughly hardened, check the foundation bolt nuts, and tighten, if necessary.</p> <p>Approximately two weeks after the grout has been poured, or when the grout has thoroughly dried, apply an oil-based paint to the exposed edges of the grout to prevent air and moisture from getting in contact with the grout.</p>	<p style="writing-mode: vertical-rl; transform: rotate(180deg);">TM04 0490 0708/TM04 0491 0708</p> <p style="writing-mode: vertical-rl; transform: rotate(180deg);">TM03 4590 2206</p> <p style="writing-mode: vertical-rl; transform: rotate(180deg);">TM03 2946 4707</p>

## 7.6 Pipework

### 7.6.1 Piping

When installing the pipes, make sure that the pump housing is not stressed by the pipework.

The suction and discharge pipes must be of an adequate size, taking the pump inlet pressure into account.

Install the pipes so that air locks are avoided, especially on the suction side of the pump.

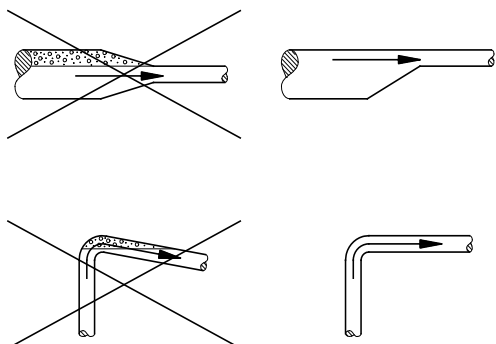


Fig. 16 Pipelines

Fit isolating valves on either side of the pump to avoid having to drain the system if the pump needs to be cleaned or repaired. Make sure the pipes are adequately supported as close to the pump as possible, both on the suction and the discharge side. The counter flanges should lie true against the pump flanges without being stressed as this will cause damage to the pump.

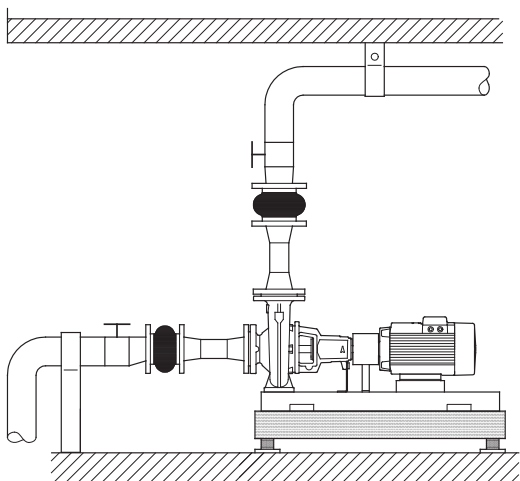


Fig. 17 Pipeline mounting

### 7.6.2 Direct mounting in pipework

Pumps fitted with motors up to and including frame size 132 are suitable for direct mounting in supported pipework.

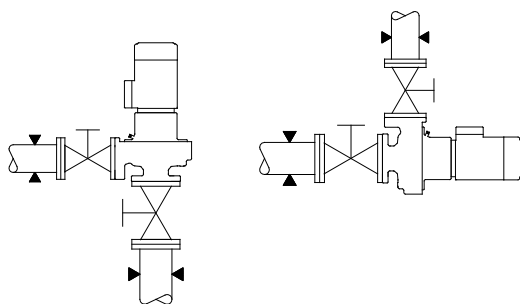


Fig. 18 Direct mounting in pipework

This type of installation does not allow the use of expansion joints. To ensure quiet operation, the pipes should be suspended from suitable pipe hangers.

### 7.6.3 Bypass

#### Warning



**The pump is not allowed to run against a closed valve as this will cause an increase in temperature/formation of steam in the pump which may cause damage to the pump.**

If there is any danger of the pump running against a closed discharge valve, a minimum liquid flow through the pump should be ensured by connecting a bypass/a drain to the discharge pipe. The minimum flow rate must be at least 10 % of the maximum flow rate. The flow rate and head are stated on the pump nameplate.

## 7.7 Vibration dampening

### 7.7.1 Elimination of noise and vibrations

In order to achieve optimum operation and minimum noise and vibration, consider vibration dampening of the pump. Generally, always consider this for pumps with motors of 11 kW and up, but for motors of 90 kW and up vibration dampening should be considered as mandatory. Smaller motor sizes, however, may also cause undesirable noise and vibration.

Noise and vibration are generated by the revolutions of the motor and pump and by the flow in pipes and fittings. The effect on the environment is subjective and depends on correct installation and the state of the remaining system.

Elimination of noise and vibrations is best achieved by means of a concrete foundation, vibration dampers and expansion joints.

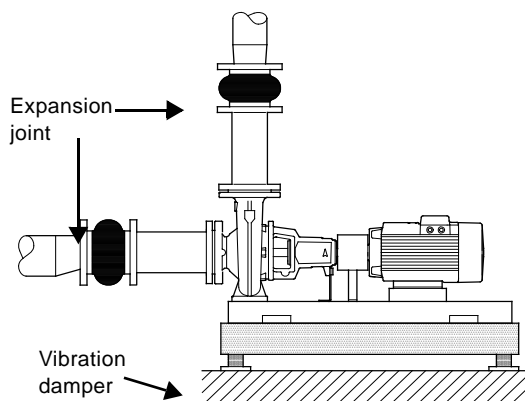


Fig. 19 NK, NKE pump with expansion joints and vibration dampers

### 7.7.2 Vibration dampers

To prevent the transmission of vibrations to buildings, we recommend you to isolate the pump foundation from building parts by means of vibration dampers.

The selection of the right vibration damper requires the following data:

- forces transmitted through the damper
- motor speed considering speed control, if any
- required dampening in % (suggested value is 70 %).

The selection of vibration damper differs from installation to installation. In certain cases, a wrong damper may increase the vibration level. Vibration dampers should therefore be sized by the supplier of the vibration dampers.

If you install the pump on a foundation with vibration dampers, always fit expansion joints on the pump flanges. This is important to prevent the pump from "hanging" in the flanges.

TM00 2263 3393

TM02 5679 2707

TM00 6326 3395

TM02 5678 3802

### 7.8 Expansion joints

Expansion joints provide these advantages:

- Absorption of thermal expansion and contraction of pipework caused by variations in liquid temperature.
- Reduction of mechanical influences in connection with pressure surges in the pipework.
- Isolation of structure-borne noise in the pipework (only rubber bellows expansion joints).

**Note**

*Do not install expansion joints to make up for inaccuracies in the pipework, such as centre displacement or misalignment of flanges.*

The expansion joints should be fitted at a minimum distance of 1 to 1 1/2 pipe diameters (DN) away from the pump on the suction and the discharge side. This prevents turbulence in the joints, thus ensuring optimum suction conditions and minimum pressure loss on the discharge side. At flow velocities > 5 m/s, we recommend you to fit larger expansion joints matching to the pipework.

Figures 20 and 21 show examples of rubber bellows expansion joints with or without limiting rods.



**Fig. 20** Rubber bellows expansion joint with limiting rods

TM02 4979 1902



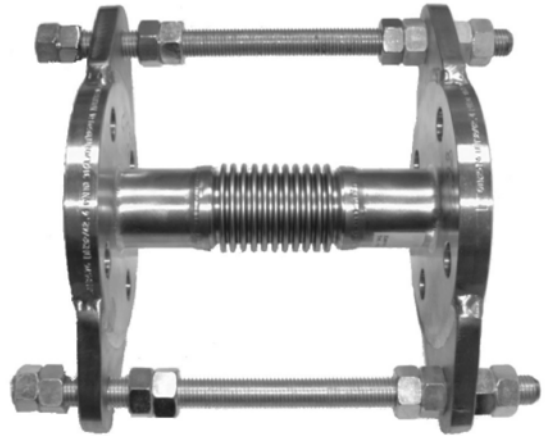
**Fig. 21** Rubber bellows expansion joint without limiting rods

TM02 4981 1902

Expansion joints with limiting rods can be used to reduce the effects of the expansion/contraction forces on the pipework. We always recommend expansion joints with limiting rods for flanges larger than DN 100.

Anchor the pipes in such a way that they do not stress the expansion joints and the pump. Follow the supplier's instructions and pass them on to advisers or pipe installers.

Figure 22 shows an example of a metal bellows expansion joint with limiting rods.



TM02 4980 1902

**Fig. 22** Metal bellows expansion joint with limiting rods

Due to the risk of rupture of the rubber bellows, metal bellows expansion joints may be preferred at temperatures above +100 °C combined with high pressure.

### 7.9 Measuring instruments

To ensure continuous monitoring of operation, it is recommended to install a pressure gauge (on the discharge side) and a manovacuum gauge (on the suction side). The pressure gauge taps should only be opened for test purposes. The measuring range of the gauges should be 20 % above the maximum pump discharge pressure.

When measuring with pressure gauges on the pump flanges, it should be noted that a pressure gauge does not register dynamic pressure (velocity pressure). On all NB pumps, the diameters of the suction and discharge flanges are different which results in different flow velocities at the two flanges. Consequently, the pressure gauge on the discharge flange will not show the pressure stated in the technical documentation, but a value which may be up to 1.5 bar (approx. 15 metres) lower.

To check the motor load, it is recommended to connect an ammeter.

## 8. Flange forces and torques

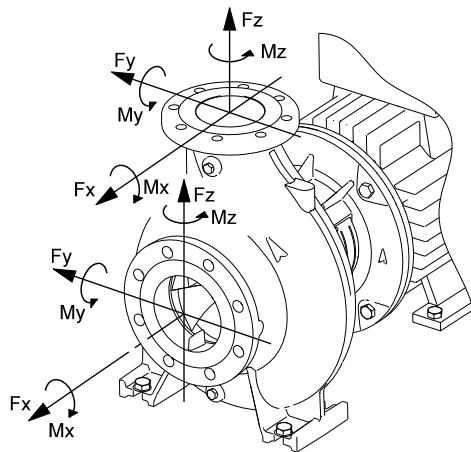


Fig. 23 Flange forces and torques

Grey cast iron	Diameter DN	Force [N]				Torque [Nm]			
		Fy	Fz	Fx	$\Sigma F^*$	My	Mz	Mx	$\Sigma M^*$
Horizontal pump, z-axis, discharge port	32	315	298	368	578	263	298	385	560
	40	385	350	438	683	315	368	455	665
	50	525	473	578	910	350	403	490	718
	65	648	595	735	1155	385	420	525	770
	80	788	718	875	1383	403	455	560	823
	100	1050	945	1173	1838	438	508	613	910
	125	1243	1120	1383	2170	525	665	735	1068
	150	1575	1418	1750	2748	613	718	875	1278
	200	2095	2600	2100	4055	805	928	1138	1680
	250	2700	3340	2980	5220	1260	1460	1780	2620
Horizontal pump, x-axis, suction port	50	578	525	473	910	350	403	490	718
	65	735	648	595	1155	385	420	525	770
	80	875	788	718	1383	403	455	560	823
	100	1173	1050	945	1838	438	508	613	910
	125	1383	1243	1120	2170	525	665	735	1068
	150	1750	1575	1418	2748	613	718	875	1278
	200	2345	2100	1890	3658	805	928	1138	1680
	250	2980	2700	3340	5220	1260	1460	1780	2620
	300	3580	3220	4000	6260	1720	1980	2420	3560
	350	4180	3760	4660	7300	2200	2540	3100	4560
Stainless steel	Diameter DN	Force [N]				Torque [Nm]			
		Fy	Fz	Fx	$\Sigma F^*$	My	Mz	Mx	$\Sigma M^*$
Horizontal pump, z-axis, discharge port	32	630	595	735	1155	525	595	770	1120
	40	770	700	875	1365	630	735	910	1330
	50	1050	945	1155	1820	700	805	980	1435
	65	1295	1190	1470	2310	770	840	1050	1540
	80	1575	1435	1750	2765	805	910	1120	1645
	100	2100	1890	2345	3675	875	1015	1225	1820
	125	2485	2240	2765	4340	1050	1330	1470	2135
	150	3150	2835	3500	5495	1225	1435	1750	2555
Horizontal pump, x-axis, suction port	50	1155	1050	945	1820	700	805	980	1435
	65	1470	1295	1190	2310	770	840	1050	1540
	80	1750	1575	1435	2765	805	910	1120	1645
	100	2345	2100	1890	3675	875	1015	1225	1820
	125	2765	2485	2240	4340	1050	1330	1470	2135
	150	3500	3150	2835	5495	1225	1435	1750	2555
	200	4690	4200	3780	7315	1610	1855	2275	3360

\*  $\Sigma F$  and  $\Sigma M$  are the vector sums of the forces and torques.

If not all loads reach the maximum permissible value, one of the values is allowed to exceed the normal limit. Contact Grundfos for further information.

## 9. Electrical connection

The electrical connection must be carried out by a qualified electrician in accordance with local regulations.

### Warning



**Before removing the terminal box cover and before any removal/dismantling of the pump, make sure that the power supply has been switched off.**

**The pump must be connected to an external mains switch.**

The operating voltage and frequency are marked on the nameplate. Make sure that the motor is suitable for the power supply of the installation site.

The electrical connection should be carried out as shown in the wiring diagram inside the terminal box cover.

### Warning



**Whenever powered equipment is being used in explosive surroundings, the rules and regulations generally or specifically imposed by the relevant responsible authorities or trade organisations must be observed.**

## 9.1 Motor protection

Three-phase motors must be connected to a motor-protective circuit breaker.

All three-phase Grundfos MG and MMG motors of 3 kW and up incorporate a thermistor. See the instructions in the motor terminal box.

Carry out the electrical connection as shown in the diagram inside the terminal box cover.

### Warning



**Before starting any repair work on motors incorporating a thermal switch or thermistors, it must be ensured that the motor cannot restart automatically after cooling.**

## 9.2 Frequency converter operation

All three-phase motors can be connected to a frequency converter.

Frequency converter operation will often expose the motor insulation system to a heavier load and cause the motor to be more noisy than usual due to eddy currents caused by voltage peaks.

Large motor driven via a frequency converter will be loaded by bearing currents.

Check these operating conditions if the pump is driven via a frequency converter:

Operating conditions	Action
2-, 4- and 6-pole motors, frame size 280 and up	Check that one of the motor bearings is electrically isolated. Contact Grundfos.
Noise critical applications	Fit a dU/dt filter between the motor and the frequency converter (reduces the voltage peaks and thus the noise).
Particularly noise critical applications	Fit a sinusoidal filter.
Cable length	Fit a cable that meets the specifications laid down by the frequency converter supplier. (The length of the cable between motor and frequency converter affects the motor load.)
Supply voltage up to 500 V	Check that the motor is suitable for frequency converter operation.
Supply voltage between 500 V and 690 V	Fit a dU/dt filter between the motor and frequency converter (reduces the voltage peaks and thus the noise), <b>or</b> check that the motor has reinforced insulation.
Supply voltage of 690 V and higher	Fit a dU/dt filter <b>and</b> check that the motor has reinforced insulation.

## 10. Start-up

Note

*Do not start the pump until it has been filled with liquid and vented.*

### 10.1 General information

Warning



*When pumping drinking water, the pump should be flushed through with clean water before start-up in order to remove any foreign matters such as preservatives, test liquid or grease.*

### 10.2 Priming

**Closed systems or open systems where the liquid level is above the pump inlet**

1. Close the discharge isolating valve and slowly open the isolating valve in the suction pipe. Both the pump and the suction pipe should be completely filled with liquid.
2. Slacken the priming plug in order to vent the pump. Once liquid runs out, tighten the priming plug.

Warning

*Pay attention to the orientation of the priming hole to ensure that the escaping water does not cause personal injury or damage to the motor or other components.*



*In hot-water installations, special attention should be paid to the risk of personal injury caused by scalding hot water.*

**Suction operation with non-return valve**

The suction pipe and the pump must be filled with liquid and vented before the pump is started.

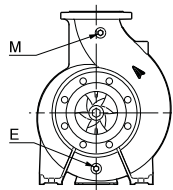
1. Close the discharge isolating valve and slowly open the isolating valve in the suction pipe.
2. Remove the priming plug (M).
3. Pour liquid through the hole until the suction pipe and the pump are completely filled with liquid.
4. Fit the priming plug (M).

The suction pipe may be filled and vented via the priming plug. See fig. 24. Alternatively a priming device with funnel can be installed before the pump.

**Open systems where the liquid level is below the pump inlet**

1. If an isolating valve is fitted on the suction side of the pump, the valve must be fully open.
2. Close the discharge isolating valve and tighten the priming and drain plugs.
3. Connect a manual venting pump instead of a priming device (funnel).
4. A slide valve should be installed between the venting pump and the centrifugal pump in order to protect the venting pump against excessive pressure.
5. Once the slide valve at the manual venting pump has been opened, vent the suction pipe using short, rapid pump strokes until the liquid runs out on the discharge side.
6. Close the valve at the venting pump.

E: Drain plug  
M: Priming plug



TM03 3935 1206

Fig. 24 Drain and priming plug

### 10.3 Checking the direction of rotation



Warning

*The pump must be filled with liquid when checking the direction of rotation.*

The correct direction of rotation is shown by arrows on the pump housing. Seen from the pump end, the direction of rotation must be counter-clockwise. See fig. 24.

### 10.4 Start-up

Before starting the pump, completely open the isolating valve on the suction side of the pump and leave the isolating valve on the discharge side almost closed.

Start the pump.

Vent the pump during starting by loosening the air vent screw in the pump head/cover until a steady stream of liquid runs out of the vent hole.

Warning

*Pay attention to the orientation of the vent hole to ensure that the escaping water does not cause personal injury or damage to the motor or other components.*



*In hot-water installations, special attention should be paid to the risk of personal injury caused by scalding hot water.*

When the pipework has been filled with liquid, slowly open the isolating valve on the discharge side until it is completely open.

Warning

*If the motor is fitted with a motor with an output selected on the basis of a specific maximum flow rate, the motor may be overloaded if the differential pressure is lower than anticipated.*



Check the overload by measuring the motor current consumption and comparing the value with the nominal current stated on the motor nameplate. In case of overload, throttle the valve on the discharge side until the motor is no longer overloaded.

It is advisable always to measure the motor current consumption during starting.

Note

*At the moment of start, the input current of the pump motor is up to six times higher than the full-load current stated on the motor nameplate.*

### 10.5 Start/stop

Frame size	Maximum number of starts/hour		
	Number of poles		
	2	4	6
56 - 71	100	250	350
80 - 100	60	140	160
112 - 132	30	60	80
160 - 180	15	30	50
200 - 225	8	15	30
250 - 315	4	8	12



## 11. Maintenance



### Warning

**Before starting work on the pump, switch off the supply voltage. It must be ensured that it cannot be accidentally switched on.**

### 11.1 Pump

The pump is maintenance-free.

If the pump is to be drained for a long period of inactivity, inject a few drops of silicone oil on the shaft at the bearing bracket. This will prevent the shaft seal faces from sticking.

### 11.2 Mechanical shaft seals

Mechanical shaft seals are maintenance-free, working almost without any leakages. If any considerable and increasing seepage occurs, the mechanical shaft seal should be checked immediately. If the sliding surfaces are damaged, the entire shaft seal should be replaced. Mechanical shaft seals should be treated with the greatest care.

### 11.3 Motor

Check the motor at regular intervals. It is important to keep the motor clean in order to ensure adequate ventilation. If the pump is installed in a dusty environment, the pump must be cleaned and checked regularly.

### 11.4 Lubrication

#### Motor bearings

Motors up to and including frame size 132 have maintenance-free, greased-for-life bearings.

Motors of frame sizes larger than 132 should be greased according to the indications on the motor nameplate. Grease spills from the motor may occur.

Grease specifications: See 11.4.1 Bearing grease.

#### 11.4.1 Bearing grease

Lithium-based grease according to the following specifications must be used:

- NLGI class 2 or 3.
- Viscosity of basic oil: 70 to 150 cSt at +40 °C.
- Temperature range: –30 °C to +140 °C during continuous operation.

## 12. Periods of inactivity and frost protection

Pumps which are not being used during periods of frost should be drained to avoid damage.

Drain the pump by removing the drain plug. See fig. 24.

Do not tighten the priming plug and replace the drain plug until the pump is to be used again.

### Warning

**Pay attention to the escaping liquid which may cause personal injury or damage to the motor or other components.**

**In hot-water installations, special attention should be paid to the risk of personal injury caused by scalding hot water.**



## 13. Service



### Warning

**If a pump has been used for a liquid which is injurious to health or toxic, the pump will be classified as contaminated.**

If Grundfos is requested to service the pump, Grundfos must be contacted with details about the pumped liquid, etc. before the pump is returned for service. Otherwise Grundfos can refuse to accept the pump for service.

Possible costs of returning the pump are paid by the customer.

### 13.1 Service kits

Service kits for NB, NBG, see [www.Grundfos.com](http://www.Grundfos.com) (WebCAPS), WinCAPS or Service Kit Catalogue.

## 14. Calculation of minimum inlet pressure

The minimum inlet pressure "H" in metres head required during operation to avoid cavitation in the pump can be calculated from the following formula:

$$H = p_b \times 10.2 - \text{NPSH} - H_f - H_v - H_s$$

<b>p<sub>b</sub></b>	Barometric pressure in bar. (The barometric pressure can be taken as = 1 bar.) In closed systems p <sub>b</sub> indicates system pressure in bar.
<b>NPSH</b>	Net Positive Suction Head in metres head (to be read from the NPSH curve on page 599 at the highest flow the pump will be delivering). The maximum flow rate must not exceed the values stated for the individual pump on page 585.
<b>H<sub>f</sub></b>	Friction loss in suction pipe in metres head.
<b>H<sub>v</sub></b>	Vapour pressure in metres head, see page 605, where t <sub>m</sub> = liquid temperature.
<b>H<sub>s</sub></b>	<b>Safety margin = min. 0.5 metres head.</b>

If the calculated value of H is positive, the pump can operate with a maximum suction lift of "H" metres.

If the calculated value of H is negative, a minimum suction head of "H" metres is required. The calculated "H" must be present during operation.

#### Example:

p<sub>b</sub> = 1 bar.

Pump type: NB 50-200/219, 2-pole, 50 Hz.

Flow rate: 70 m<sup>3</sup>/h.

NPSH (read on page 599): 2.35 metres head.

H<sub>f</sub> = 3.0 metres head.

Liquid temperature: +90 °C.

H<sub>v</sub> (read on page 605): 7.2 metres head.

$H = p_b \times 10.2 - \text{NPSH} - H_f - H_v - H_s$  [metres head].

$H = 1 \times 10.2 - 2.35 - 3.0 - 7.2 - 0.5 = -2.85$  metres head.

This means that a suction head of 2.85 metres is required during operation.

The inlet pressure calculated in bar: 2.85 x 0.0981 = 0.28 bar.

The inlet pressure calculated in kPa: 2.85 x 9.81 = 28 kPa.

## 15. Fault finding chart



### Warning

Before removing the terminal box cover and before any removal/dismantling of the pump, make sure that the power supply has been switched off. It must be ensured that it cannot be accidentally switched on.

GB

Fault	Cause	Remedy
1. The pump delivers no or too little liquid.	a) Wrong electrical connection (2 phases).	Check the electrical connection and remedy, if necessary.
	b) Wrong direction of rotation.	Interchange two phases of the power supply.
	c) Air in suction pipe.	Vent the suction pipe or the pump and replenish.
	d) Counter-pressure too high.	Set the duty point in accordance with the data sheet. Check the system for impurities.
	e) Inlet pressure too low.	Increase the liquid level on the suction side. Open the isolating valve in the suction pipe. Make sure that all the conditions in 7.6 <i>Pipework</i> are complied with.
	f) Suction pipe or impeller blocked by impurities.	Clean the pump.
	g) Pump draws in air due to defective seal.	Check the pipeline seals, pump housing gaskets and shaft seals, and replace, if necessary.
	h) Pump draws in air due to low liquid level.	Increase the liquid level on the suction side and keep it as constant as possible.
2. The motor-protective circuit breaker has tripped because the motor is overloaded.	a) Pump blocked by impurities.	Clean the pump.
	b) Pump running above the rated duty point.	Set the duty point in accordance with the data sheet.
	c) Density or viscosity of the liquid is higher than specified when ordering.	If less flow is sufficient, reduce the flow on the discharge side. Or fit a more powerful motor.
	d) Motor-protective circuit breaker overload setting is incorrect.	Check the setting of the motor-protective circuit breaker and replace, if necessary.
	e) The motor runs on 2 phases.	Check the electrical connection. Replace the fuse, if defective.
3. Pump makes too much noise. Pump runs unevenly and vibrates.	a) Inlet pressure too low (cavitation).	Increase the liquid level on the suction side. Open the isolating valve in the suction pipe. Make sure that all the conditions in 7.6 <i>Pipework</i> are complied with.
	b) Air in suction pipe or pump.	Vent the suction pipe or the pump and replenish.
	c) Counter-pressure is lower than specified.	Set the duty point in accordance with the data sheet.
	d) Pump draws in air due to low liquid level.	Increase the liquid level on the suction side and keep it as constant as possible.
	e) Impeller out of balance (clogged impeller blades).	Clean and check the impeller.
	f) Inner parts worn.	Replace defective parts.
	g) Pump stressed by the pipework (thus causing starting noise).	Mount the pump so that it is not stressed. Support the pipes.
	h) Defective bearings.	Replace the bearings.
	i) Defective motor fan.	Replace the fan.
	j) Foreign bodies in the pump.	Clean the pump.
	k) Frequency converter operation.	See 9.2 <i>Frequency converter operation</i> .
4. Leakage in pump or at connections. Leakage in mechanical shaft seal.	a) Pump stressed by the pipework (thus causing leaks in the pump or at connections).	Mount the pump so that it is not stressed. Support the pipes.
	b) Pump housing gaskets and gaskets at connections defective.	Replace pump housing gaskets or gaskets at connections.
	c) Mechanical shaft seal dirty or stuck together.	Check and clean the mechanical shaft seal.
	d) Mechanical shaft seal defective.	Replace the mechanical shaft seal.
	e) Shaft surface defective.	Replace the shaft.
5. Too high temperature in pump or motor.	a) Air in suction pipe or pump.	Vent the suction pipe or the pump and replenish.
	b) Inlet pressure too low.	Increase the liquid level on the suction side. Open the isolating valve in the suction pipe. Make sure that all the conditions in 7.6 <i>Pipework</i> are complied with.
	c) Bearings lubricated with too little, too much or unsuitable lubricant.	Replenish, reduce or replace lubricant.
	d) The axial pressure is too high.	Check the relief holes of the impeller and the lock rings on the suction side.
	e) Motor-protective circuit breaker is defective or setting is incorrect.	Check the setting of the motor-protective circuit breaker and replace, if necessary.
	f) The motor is overloaded.	Reduce the flow rate.

## 16. Disposal

This product or parts of it must be disposed of in an environmentally sound way:

1. Use the public or private waste collection service.

2. If this is not possible, contact the nearest Grundfos company or service workshop.

Subject to alterations.

## Airborne noise emitted by pumps with MG, MMG, Siemens and TECO motors

50 Hz

2-pole:  $n = 2900 \text{ min}^{-1}$

4-pole:  $n = 1450 \text{ min}^{-1}$

6-pole:  $n = 970 \text{ min}^{-1}$

Motor [kW]	L <sub>pA</sub> [dB(A)]													
	MG model B	MG model C		MG model D	Siemens			MMG model E			TECO			
	4-pole	2-pole	4-pole	2-pole	2-pole	4-pole	6-pole	2-pole	4-pole	6-pole	2-pole	4-pole	6-pole	
0.25	42													
0.37	42						40			51		58	59	
0.55			42				40			51	60	58	59	
0.75		56	42				43			52	62	58	59	
1.1		55	51	59			48	43		52	62	59	59	
1.5		58	55	58			48	47		53	64	59	59	
2.2		57	52	60			53	52		57	64	62	59	
3.0		59	56	59			53	63		61	65	62	58	
4.0		66	59	63			53	63		61	65	63	61	
5.5		63	57	63			62	63		61	70	63	60	
7.5		73		68			62	66	63	65	73	62	61	
11.0						70	66	66	78	67	65	76	69	62
15.0						70	66	66	78	67	65	76	69	65
18.5						70	63	66	78	68	68	76	72	69
22.0						70	63	66	82	68	68	83	72	70
30.0						71	65	59	84	71	68	88	76	74
37.0						71	66	60	84	73	70	88	82	75
45.0						71	66	58	84	73	72	90	82	75
55.0						71	67	58	85	75	72	91	83	81
75.0						73	70	61	86	78	77	91	83	81
90.0						73	70	61	86	78	77	92	85	84
110.0						76	70	61	89	85	77	92	85	84
132.0						76	70	61	89	85		93	88	84
160.0						76	70		92	89		93	90	
200.0						76	70		92	89		93	90	
250.0						82	73		95	93		95	92	
315.0						82	73		95	93		95	94	
355.0						77								

**60 Hz**

2-pole:  $n = 3500 \text{ min}^{-1}$

4-pole:  $n = 1750 \text{ min}^{-1}$

6-pole:  $n = 1170 \text{ min}^{-1}$

Motor [kW]	L <sub>pA</sub> [dB(A)]												
	MG model B	MG model C		MG model D	Siemens		MMG model E			TECO			
	4-pole	2-pole	4-pole	2-pole	2-pole	4-pole	6-pole	2-pole	4-pole	6-pole	2-pole	4-pole	6-pole
0.25	42		45										
0.37	42		45				40			53		58	59
0.55			45				40			53	60	58	59
0.75		57	49				43			54	63	58	59
1.1		60	55	63			52	43		54	63	59	59
1.5		63	53	64			52	47		55	64	59	59
2.2		63	54	65			57	52		59	65	62	59
3.0		71	59	64			57	63		63	66	62	59
4.0		71	61	68			57	63		63	66	63	61
5.5		78	68	67			62	63		63	73	63	60
7.5		78		73			62	66	65	67	74	62	61
11.0					70	66	66	80	69	67	76	69	62
15.0					70	66	66	80	69	67	76	69	65
18.5					70	63	66	80	70	70	76	72	69
22.0					70	63	66	84	70	70	83	72	70
30.0					71	65	62	86	73	70	88	76	74
37.0					71	65	63	86	75	72	88	82	75
45.0					75	65	62	86	75	74	90	82	75
55.0					75	68	62	87	77	74	91	83	78
75.0					77	71	66	88	80	79	91	83	80
90.0					77	71	66	88	80	79	90	86	80
110.0					81	75	66	91	87	79	92	88	81
132.0					81	75	66	91	87		92	88	81
160.0					81	75		94	91		92	90	
200.0					81	75		94	91		92	91	
250.0								97	95		95	93	
315.0								97	95		95	95	

**Maximum flow rate**

**NB, 50 Hz**

2-pole: n = 2900 min <sup>-1</sup>		4-pole: n = 1450 min <sup>-1</sup>		6-pole: n = 970 min <sup>-1</sup>	
Pump type	Max. Q [m <sup>3</sup> /h]	Pump type	Max. Q [m <sup>3</sup> /h]	Pump type	Max. Q [m <sup>3</sup> /h]
32-125/97	29.8	32-125.1/116	11.0	100-160/160-142	92.9
32-125/107	32.1	32-125.1/132	12.9	100-160/163	103.5
32-125/122	37.4	32-125.1/140	14.0	100-160/176	117.0
32-125/130	40.0	32-160.1/147	12.1	100-200/182	109.9
32-125/142	44.0	32-160.1/164	14.3	100-200/194	118.4
32-125.1/95	18.2	32-160.1/177	16.0	100-200/214	135.8
32-125.1/104	20.5	32-200.1/168	12.9	100-200/219	150.0
32-125.1/116	23.6	32-200.1/185	14.7	100-250/220	120.6
32-125.1/129	26.8	32-200.1/202	16.6	100-250/236	136.1
32-125.1/140	30.0	32-200.1/207	17.0	100-250/259	149.9
32-160/128	29.3	32-125/109	16.7	100-250/270	158.0
32-160/139	33.2	32-125/123	18.9	100-315/272	126.3
32-160/152	38.1	32-125/140	21.5	100-315/301	143.0
32-160/168	42.2	32-125/142	22.0	100-315/326	159.6
32-160/177	47.0	32-160/131	14.5	100-315/334	166.0
32-160.1/133	19.6	32-160/147	17.2	100-400/360	116.4
32-160.1/145	22.6	32-160/162	19.8	100-400/406	139.1
32-160.1/156	25.6	32-160/177	23.0	100-400/437	168.3
32-160.1/170	29.1	32-200/174	16.0	100-400/438	174.0
32-160.1/177	31.0	32-200/189	18.7	125-200/188-180	159.6
32-200/164	30.4	32-200/204	21.3	125-200/205	175.3
32-200/179	34.7	32-200/219	24.0	125-200/218	189.9
32-200/197	40.8	32-250/198	13.2	125-200/226	200.0
32-200/212	46.8	32-250/218	15.2	125-250/216	197.3
32-200/219	49.0	32-250/243	17.6	125-250/232	216.0
32-200.1/158	23.2	32-250/262	19.0	125-250/253	244.0
32-200.1/175	26.4	40-125/111	28.5	125-250/269	268.0
32-200.1/192	29.7	40-125/123	31.4	125-315/275	206.3
32-200.1/207	32.0	40-125/137	34.0	125-315/297	229.2
32-250/207	26.9	40-125/142	36.0	125-315/335	272.2
32-250/227	30.6	40-160/128	25.3	125-315/338	281.0
32-250/242	33.2	40-160/143	28.6	125-400/351	181.8
32-250/256	35.3	40-160/155	32.1	125-400/384	207.9
32-250/262	36.0	40-160/170	35.9	125-400/410	229.5
40-125/110	51.0	40-160/177	38.0	125-400/434	248.3
40-125/118	59.3	40-200/169	28.3	125-400/438	253.0
40-125/131	61.4	40-200/184	32.1	125-500/421	194.3
40-125/140	69.7	40-200/205	37.4	125-500/445	209.5
40-125/142	71.0	40-200/219	41.0	125-500/493	239.0
40-160/131	52.4	40-250/207	31.9	125-500/524	266.8
40-160/143	57.9	40-250/225	35.1	125-500/546	302.9
40-160/162	66.9	40-250/246	38.9	125-500/548	310.0
40-160/177	74.0	40-250/260	43.0	150-200/210-170	291.6
40-200/178	58.7	40-315/284	30.1	150-200/218-200	316.1
40-200/193	66.6	40-315/313	33.9	150-200/224	334.0
40-200/206	72.7	40-315/344	38.0	150-250/243	351.1
40-200/216	77.8	50-125/109	45.9	150-250/262	379.4
40-200/219	79.0	50-125/120	51.2	150-250/286	416.0
40-250/193	60.0	50-125/132	57.5	150-315/280	398.3
40-250/206	64.8	50-125/144	62.0	150-315/305	450.6
40-250/215	69.3	50-160/134	47.7	150-315/322	489.2
40-250/236	76.8	50-160/146	52.7	150-315/337	525.4
40-250/252	83.0	50-160/165	60.5	150-315/338	533.0
50-125/105	70.0	50-160/177	66.0	150-400/357	364.1
50-125/113	93.3	50-200/178	51.3	150-400/375	388.8
50-125/124	103.8	50-200/193	58.8	150-400/408	446.9
50-125/140	116.7	50-200/210	67.1	150-400/430	497.3
50-125/144	120.0	50-200/219	70.0	150-400/438	520.0
50-160/127	85.3	50-250/221	55.2	150-500/457	353.4
50-160/141	96.8	50-250/244	64.5	150-500/483	380.6
50-160/154	107.9	50-250/263	73.0	150-500/513	411.4
50-160/165	117.3	50-315/256	40.6	150-500/548	480.0
50-160/177	126.0	50-315/283	46.3		

2-pole: n = 2900 min <sup>-1</sup>		4-pole: n = 1450 min <sup>-1</sup>		6-pole: n = 970 min <sup>-1</sup>	
Pump type	Max. Q [m <sup>3</sup> /h]	Pump type	Max. Q [m <sup>3</sup> /h]	Pump type	Max. Q [m <sup>3</sup> /h]
50-200/167	92.5	50-315/314	53.7		
50-200/178	99.5	50-315/344	60.0		
50-200/187	107.4	65-125/124	78.1		
50-200/205	121.8	65-125/136	84.0		
50-200/218	130.8	65-125/144	92.0		
50-250/213	107.4	65-160/141	74.2		
50-250/229	113.9	65-160/156	83.2		
65-125/120-110	148.2	65-160/169	91.7		
65-125/130	157.9	65-160/177	97.0		
65-125/141	174.0	65-200/174	75.9		
65-125/144	180.0	65-200/189	84.8		
65-160/136	137.4	65-200/209	95.6		
65-160/147	154.9	65-200/219	102.0		
65-160/155	163.1	65-250/215	78.2		
65-160/163	173.8	65-250/238	88.8		
65-160/177	190.0	65-250/265	102.6		
65-200/160	132.0	65-250/270	107.0		
65-200/168	140.1	65-315/242	80.4		
65-200/184	158.4	65-315/270	96.5		
65-200/195	171.2	65-315/290	111.1		
65-250/212	151.2	65-315/305	121.7		
65-250/226	164.4	65-315/320	132.0		
65-250/248	185.4	80-160/150	134.4		
65-250/263	199.2	80-160/161	143.3		
65-250/270	209.0	80-160/177	156.0		
80-160/150-130	263.4	80-200/167	109.7		
80-160/156	286.6	80-200/184	124.5		
80-160/165	302.1	80-200/202	139.3		
80-200/169	244.3	80-200/222	164.0		
80-200/179	262.4	80-250/211	118.5		
80-200/192	288.0	80-250/234	138.6		
80-200/207	324.0	80-250/255	158.2		
80-200/222	343.0	80-250/270	173.0		
80-250/218	267.2	80-315/275	155.9		
80-250/230	287.7	80-315/287	167.5		
80-250/244	311.1	80-315/314	195.2		
80-250/259	338.0	80-315/332	213.7		
80-250/270	360.0	80-315/334	216.0		
100-160/160-154	348.2	80-400/342	143.3		
100-200/173	380.2	80-400/362	158.6		
100-200/192	415.5	80-400/380	175.1		
100-200/201	439.0	80-400/401	197.1		
100-200/212	470.8	80-400/437	222.7		
100-200/219	492.0	80-400/438	227.0		
100-250/217	405.4	100-160/160-146	171.3		
100-250/231	427.5	100-160/165	193.6		
100-250/243	455.8	100-160/176	210.0		
100-250/261	495.1	100-200/166	195.0		
125-200/188-168	498.4	100-200/182	213.1		
125-200/188	520.8	100-200/201	236.6		
125-200/200	552.4	100-200/217	264.3		
125-200/211	578.1	100-200/219	270.0		
125-200/223	613.2	100-250/223	225.4		
125-200/226	625.0	100-250/236	242.2		
125-250/226	495.1	100-250/249	257.1		
125-250/242	540.6	100-250/270	283.0		
150-200/210-154	865.5	100-315/264	213.3		
150-200/216-176	920.0	100-315/290	241.0		
150-200/218-204	950.1	100-315/309	260.2		
150-200/224	1000.0	100-315/329	281.7		
		100-315/334	298.0		
		100-400/347	172.9		
		100-400/367	186.7		
		100-400/392	204.5		
		100-400/428	244.8		
		100-400/438	270.0		

2-pole: n = 2900 min <sup>-1</sup>		4-pole: n = 1450 min <sup>-1</sup>		6-pole: n = 970 min <sup>-1</sup>	
Pump type	Max. Q [m <sup>3</sup> /h]	Pump type	Max. Q [m <sup>3</sup> /h]	Pump type	Max. Q [m <sup>3</sup> /h]
		125-200/191	303.5		
		125-200/208	326.2		
		125-200/218	343.7		
		125-200/226	360.0		
		125-250/214	351.5		
		125-250/224	373.8		
		125-250/243	417.0		
		125-250/258	453.8		
		125-250/269	480.0		
		125-315/271	315.0		
		125-315/287	339.0		
		125-315/303	364.6		
		125-315/320	393.9		
		125-315/338	430.0		
		125-400/333	283.8		
		125-400/369	325.5		
		125-400/389	352.9		
		125-400/414	388.0		
		125-400/438	420.0		
		125-500/423	338.1		
		125-500/447	367.5		
		125-500/474	401.8		
		125-500/508	449.0		
		150-200/214-174	540.1		
		150-200/218-202	567.1		
		150-200/222	590.0		
		150-250/234	580.8		
		150-250/248	600.8		
		150-250/260	631.9		
		150-250/273	668.5		
		150-250/286	700.0		
		150-315/269	579.8		
		150-315/295	647.2		
		150-315/309	695.3		
		150-315/326	755.1		
		150-315/338	800.0		
		150-400/341	549.0		
		150-400/361	593.0		
		150-400/381	636.7		
		150-400/401	693.9		
		150-400/424	774.4		

NB, 60 Hz

2-pole: n = 3500 min <sup>-1</sup>		4-pole: n = 1750 min <sup>-1</sup>		6-pole: n = 1170 min <sup>-1</sup>	
Pump type	Max. Q [m³/h]	Pump type	Max. Q [m³/h]	Pump type	Max. Q [m³/h]
32-125/97	29.8	32-125.1/116	11.0	100-160/160-154	111.7
32-125/107	32.1	32-125.1/132	12.9	100-160/168	127.6
32-125/122	37.4	32-125.1/140	14.0	100-160/176	140.0
32-125/130	40.0	32-160.1/147	12.1	100-200/169	128.9
32-125/142	44.0	32-160.1/164	14.3	100-200/185	144.3
32-125.1/95	18.2	32-160.1/177	16.0	100-200/198	156.2
32-125.1/104	20.5	32-200.1/168	12.9	100-200/214	173.4
32-125.1/116	23.6	32-200.1/185	14.7	100-200/219	180.0
32-125.1/129	26.8	32-200.1/202	16.6	100-250/216	145.6
32-125.1/140	30.0	32-200.1/207	17.0	100-250/238	162.3
32-160/128	29.3	32-125/109	16.7	100-250/261	183.1
32-160/139	33.2	32-125/123	18.9	100-250/270	190.0
32-160/152	38.1	32-125/140	21.5	100-315/276	156.4
32-160/168	42.2	32-125/142	22.0	100-315/310	179.5
32-160/177	47.0	32-160/131	14.5	100-315/334	199.0
32-160.1/133	19.6	32-160/147	17.2	100-400/343	126.3
32-160.1/145	22.6	32-160/162	19.8	100-400/379	143.4
32-160.1/156	25.6	32-160/177	23.0	100-400/404	159.0
32-160.1/170	29.1	32-200/174	16.0	100-400/424	176.2
32-160.1/177	31.0	32-200/189	18.7	100-400/438	199.0
32-200/164	30.4	32-200/204	21.3	125-200/188	196.4
32-200/179	34.7	32-200/219	24.0	125-200/204	210.8
32-200/197	40.8	32-250/198	13.2	125-200/222	229.3
32-200/212	46.8	32-250/218	15.2	125-200/226	240.0
32-200/219	49.0	32-250/243	17.6	125-250/219	237.2
32-200.1/158	23.2	32-250/262	19.0	125-250/234	265.0
32-200.1/175	26.4	40-125/111	28.5	125-250/261	307.4
32-200.1/192	29.7	40-125/123	31.4	125-250/269	322.0
32-200.1/207	32.0	40-125/137	34.0	125-315/254	210.1
32-250/207	26.9	40-125/142	36.0	125-315/286	243.7
32-250/227	30.6	40-160/128	25.3	125-315/313	274.4
32-250/242	33.2	40-160/143	28.6	125-315/333	300.7
32-250/256	35.3	40-160/155	32.1	125-315/338	310.0
32-250/262	36.0	40-160/170	35.9	125-400/346	215.4
40-125/110	51.0	40-160/177	38.0	125-400/367	233.1
40-125/118	59.3	40-200/169	28.3	125-400/404	268.1
40-125/131	61.4	40-200/184	32.1	125-400/432	295.2
40-125/140	69.7	40-200/205	37.4	125-400/438	304.0
40-125/142	71.0	40-200/219	41.0	125-500/446	244.1
40-160/131	52.4	40-250/207	31.9	125-500/470	266.5
40-160/143	57.9	40-250/225	35.1	125-500/501	294.1
40-160/162	66.9	40-250/246	38.9	125-500/543	354.9
40-160/177	74.0	40-250/260	43.0	125-500/548	370.0
40-200/178	58.7	40-315/284	30.1	150-200/210-170	365.5
40-200/193	66.6	40-315/313	33.9	150-200/218-212	376.4
40-200/206	72.7	40-315/344	38.0	150-200/224	401.0
40-200/216	77.8	50-125/109	45.9	150-250/250	404.7
40-200/219	79.0	50-125/120	51.2	150-250/271	441.3
40-250/193	60.0	50-125/132	57.5	150-250/286	466.0
40-250/206	64.8	50-125/144	62.0	150-315/283	410.5
40-250/215	69.3	50-160/134	47.7	150-315/297	437.3
40-250/236	76.8	50-160/146	52.7	150-315/323	495.4
40-250/252	83.0	50-160/165	60.5	150-315/338	533.0
50-125/105	70.0	50-160/177	66.0	150-400/327	341.9
50-125/113	93.3	50-200/178	51.3	150-400/358	386.8
50-125/124	103.8	50-200/193	58.8	150-400/380	418.5
50-125/140	116.7	50-200/210	67.1	150-400/398	455.2
50-125/144	120.0	50-200/219	70.0	150-400/419	502.5
50-160/127	85.3	50-250/221	55.2	150-400/438	550.0
50-160/141	96.8	50-250/244	64.5	150-500/433	394.4
50-160/154	107.9	50-250/263	73.0	150-500/482	447.1
50-160/165	117.3	50-315/256	40.6	150-500/510	478.6
50-160/177	126.0	50-315/283	46.3	150-500/534	535.3
50-200/167	92.5	50-315/314	53.7	150-500/548	566.0



2-pole: n = 3500 min <sup>-1</sup>		4-pole: n = 1750 min <sup>-1</sup>		6-pole: n = 1170 min <sup>-1</sup>	
Pump type	Max. Q [m <sup>3</sup> /h]	Pump type	Max. Q [m <sup>3</sup> /h]	Pump type	Max. Q [m <sup>3</sup> /h]
50-200/178	99.5	50-315/344	60.0		
50-200/187	107.4	65-125/124	78.1		
50-200/205	121.8	65-125/136	84.0		
50-200/218	130.8	65-125/144	92.0		
50-250/213	107.4	65-160/141	74.2		
50-250/229	113.9	65-160/156	83.2		
65-125/120-110	148.2	65-160/169	91.7		
65-125/130	157.9	65-160/177	97.0		
65-125/141	174.0	65-200/174	75.9		
65-125/144	180.0	65-200/189	84.8		
65-160/136	137.4	65-200/209	95.6		
65-160/147	154.9	65-200/219	102.0		
65-160/155	163.1	65-250/215	78.2		
65-160/163	173.8	65-250/238	88.8		
65-160/177	190.0	65-250/265	102.6		
65-200/160	132.0	65-250/270	107.0		
65-200/168	140.1	65-315/242	80.4		
65-200/184	158.4	65-315/270	96.5		
65-200/195	171.2	65-315/290	111.1		
65-250/212	151.2	65-315/305	121.7		
65-250/226	164.4	65-315/320	132.0		
65-250/248	185.4	80-160/150	134.4		
65-250/263	199.2	80-160/161	143.3		
65-250/270	209.0	80-160/177	156.0		
80-160/150-130	263.4	80-200/167	109.7		
80-160/156	286.6	80-200/184	124.5		
80-160/165	302.1	80-200/202	139.3		
80-200/169	244.3	80-200/222	164.0		
80-200/179	262.4	80-250/211	118.5		
80-200/192	288.0	80-250/234	138.6		
80-200/207	324.0	80-250/255	158.2		
80-200/222	343.0	80-250/270	173.0		
80-250/218	267.2	80-315/275	155.9		
80-250/230	287.7	80-315/287	167.5		
80-250/244	311.1	80-315/314	195.2		
80-250/259	338.0	80-315/332	213.7		
80-250/270	360.0	80-315/334	216.0		
100-160/160-154	348.2	80-400/342	143.3		
100-200/173	380.2	80-400/362	158.6		
100-200/192	415.5	80-400/380	175.1		
100-200/201	439.0	80-400/401	197.1		
100-200/212	470.8	80-400/437	222.7		
100-200/219	492.0	80-400/438	227.0		
100-250/217	405.4	100-160/160-146	171.3		
100-250/231	427.5	100-160/165	193.6		
100-250/243	455.8	100-160/176	210.0		
100-250/261	495.1	100-200/166	195.0		
125-200/188-168	498.4	100-200/182	213.1		
125-200/188	520.8	100-200/201	236.6		
125-200/200	552.4	100-200/217	264.3		
125-200/211	578.1	100-200/219	270.0		
125-200/223	613.2	100-250/223	225.4		
125-200/226	625.0	100-250/236	242.2		
125-250/226	495.1	100-250/249	257.1		
125-250/242	540.6	100-250/270	283.0		
150-200/210-154	865.5	100-315/264	213.3		
150-200/216-176	920.0	100-315/290	241.0		
150-200/218-204	950.1	100-315/309	260.2		
150-200/224	1000.0	100-315/329	281.7		
		100-315/334	298.0		
		100-400/347	172.9		
		100-400/367	186.7		
		100-400/392	204.5		
		100-400/428	244.8		
		100-400/438	270.0		
		125-200/191	303.5		

2-pole: n = 3500 min <sup>-1</sup>		4-pole: n = 1750 min <sup>-1</sup>		6-pole: n = 1170 min <sup>-1</sup>	
Pump type	Max. Q [m <sup>3</sup> /h]	Pump type	Max. Q [m <sup>3</sup> /h]	Pump type	Max. Q [m <sup>3</sup> /h]
		125-200/208	326.2		
		125-200/218	343.7		
		125-200/226	360.0		
		125-250/214	351.5		
		125-250/224	373.8		
		125-250/243	417.0		
		125-250/258	453.8		
		125-250/269	480.0		
		125-315/271	315.0		
		125-315/287	339.0		
		125-315/303	364.6		
		125-315/320	393.9		
		125-315/338	430.0		
		125-400/333	283.8		
		125-400/369	325.5		
		125-400/389	352.9		
		125-400/414	388.0		
		125-400/438	420.0		
		125-500/423	338.1		
		125-500/447	367.5		
		125-500/474	401.8		
		125-500/508	449.0		
		150-200/214-174	540.1		
		150-200/218-202	567.1		
		150-200/222	590.0		
		150-250/234	580.8		
		150-250/248	600.8		
		150-250/260	631.9		
		150-250/273	668.5		
		150-250/286	700.0		
		150-315/269	579.8		
		150-315/295	647.2		
		150-315/309	695.3		
		150-315/326	755.1		
		150-315/338	800.0		
		150-400/341	549.0		
		150-400/361	593.0		
		150-400/381	636.7		
		150-400/401	693.9		
		150-400/424	774.4		

NBG, 50 Hz

2-pole: n = 2900 min <sup>-1</sup>		4-pole: n = 1450 min <sup>-1</sup>		6-pole: n = 970 min <sup>-1</sup>	
Pump type	Max. Q [m <sup>3</sup> /h]	Pump type	Max. Q [m <sup>3</sup> /h]	Pump type	Max. Q [m <sup>3</sup> /h]
50-32-125.1/100	16.2	50-32-125.1/121	10.0	125-100-160/160-142	92.9
50-32-125.1/110	18.6	50-32-125.1/139	11.6	125-100-160/163	103.5
50-32-125.1/121	21.1	50-32-125.1/140	12.0	125-100-160/176	117.0
50-32-125.1/140	25.0	50-32-160.1/137	8.8	125-100-200/182	109.9
50-32-160.1/139	18.0	50-32-160.1/155	10.5	125-100-200/194	118.4
50-32-160.1/155	21.0	50-32-160.1/172	12.3	125-100-200/214	135.8
50-32-160.1/169	23.9	50-32-160.1/177	13.0	125-100-200/219	150.0
50-32-160.1/177	26.0	50-32-200.1/175	11.5	125-100-250/220	120.6
50-32-200.1/172	21.6	50-32-200.1/196	13.9	125-100-250/236	136.1
50-32-200.1/188	23.8	50-32-200.1/207	14.0	125-100-250/259	149.9
50-32-200.1/205	26.4	50-32-125/115	14.5	125-100-250/270	158.0
50-32-200.1/207	27.0	50-32-125/130	16.3	125-100-315/272	126.3
50-32-125/106	27.2	50-32-125/142	18.0	125-100-315/301	143.0
50-32-125/115	30.0	50-32-160/138	13.2	125-100-315/326	159.6
50-32-125/130	33.7	50-32-160/154	15.3	125-100-315/334	166.0
50-32-125/142	37.0	50-32-160/172	18.0	125-100-400/360	116.4
50-32-160/139	27.4	50-32-160/177	19.0	125-100-400/406	139.1
50-32-160/151	29.7	50-32-200/184	14.7	125-100-400/437	168.3
50-32-160/163	34.4	50-32-200/200	16.6	125-100-400/438	174.0
50-32-160/177	39.0	50-32-200/216	19.6	150-125-200/188-180	159.6
50-32-200/176	28.3	50-32-200/219	20.0	150-125-200/205	175.3
50-32-200/190	31.5	50-32-250/210	11.9	150-125-200/218	189.9
50-32-200/206	36.8	50-32-250/236	13.9	150-125-200/226	200.0
50-32-200/219	41.0	50-32-250/260	15.6	150-125-250/216	197.3
50-32-250/199	21.2	50-32-250/262	16.0	150-125-250/232	216.0
50-32-250/219	24.3	65-50-125/116	25.3	150-125-250/253	244.0
50-32-250/244	28.1	65-50-125/130	27.9	150-125-250/269	268.0
50-32-250/262	30.0	65-50-125/142	30.0	150-125-315/275	206.3
65-50-125/105	45.0	65-50-160/134	22.4	150-125-315/297	229.2
65-50-125/116	46.4	65-50-160/151	25.9	150-125-315/335	272.2
65-50-125/127	53.8	65-50-160/166	29.0	150-125-315/338	281.0
65-50-125/139	57.8	65-50-160/177	32.0	150-125-400/351	181.8
65-50-125/142	59.0	65-40-200/181	25.4	150-125-400/384	207.9
65-50-160/144	48.0	65-40-200/198	29.5	150-125-400/410	229.5
65-50-160/158	53.4	65-40-200/217	33.1	150-125-400/434	248.3
65-50-160/172	59.2	65-40-200/219	34.0	150-125-400/438	253.0
65-50-160/177	62.0	65-40-250/219	28.2	150-125-500/421	194.3
65-40-200/172	46.7	65-40-250/245	32.8	150-125-500/445	209.5
65-40-200/188	53.3	65-40-250/260	36.0	150-125-500/493	239.0
65-40-200/206	61.0	65-40-315/283	24.8	150-125-500/524	266.8
65-40-200/219	66.0	65-40-315/305	27.7	150-125-500/546	302.9
65-40-250/211	51.7	65-40-315/334	30.9	150-125-500/548	310.0
65-40-250/230	59.6	65-40-315/344	32.0	200-150-200/210-170	291.6
65-40-250/245	66.7	80-65-125/113	38.9	200-150-200/218-200	316.1
65-40-250/255	67.3	80-65-125/129	45.9	200-150-200/224	334.0
65-40-250/260	69.0	80-65-125/142	50.0	200-150-250/243	351.1
65-40-315/273	42.0	80-65-125/144	52.0	200-150-250/262	379.4
65-40-315/298	47.6	80-65-160/131	37.8	200-150-250/286	416.0
65-40-315/318	51.4	80-65-160/143	41.9	200-150-315/280	398.3
65-40-315/336	54.9	80-65-160/158	47.9	200-150-315/305	450.6
80-65-125/111	76.7	80-65-160/175	53.8	200-150-315/322	489.2
80-65-125/121	86.1	80-65-160/177	55.0	200-150-315/337	525.4
80-65-125/135	93.8	80-50-200/171	40.6	200-150-315/338	533.0
80-65-125/144	100.0	80-50-200/188	45.6	200-150-400/357	364.1
80-65-160/136	77.7	80-50-200/210	56.7	200-150-400/375	388.8

2-pole: n = 2900 min <sup>-1</sup>		4-pole: n = 1450 min <sup>-1</sup>		6-pole: n = 970 min <sup>-1</sup>	
Pump type	Max. Q [m <sup>3</sup> /h]	Pump type	Max. Q [m <sup>3</sup> /h]	Pump type	Max. Q [m <sup>3</sup> /h]
80-65-160/150	86.3	80-50-200/219	58.0	200-150-400/408	446.9
80-65-160/167	98.3	80-50-250/221	46.1	200-150-400/430	497.3
80-65-160/177	105.0	80-50-250/241	52.3	200-150-400/438	520.0
80-50-200/181	83.3	80-50-250/263	61.0	200-150-500/457	353.4
80-50-200/198	95.8	80-50-315/277	37.2	200-150-500/483	380.6
80-50-200/210	104.5	80-50-315/303	42.2	200-150-500/513	411.4
80-50-200/219	110.0	80-50-315/333	47.5	200-150-500/548	480.0
80-50-250/205	85.0	80-50-315/344	50.0		
80-50-250/222	87.9	100-80-125/122	63.2		
80-50-250/233	94.8	100-80-125/133	68.0		
80-50-250/254	109.2	100-80-125/144	77.0		
80-50-250/263	116.0	100-80-160/138	59.5		
80-50-315/267	68.8	100-80-160/149	65.8		
80-50-315/285	75.3	100-80-160/165	73.4		
80-50-315/300	81.1	100-80-160/177	81.0		
80-50-315/321	88.0	100-65-200/170	60.1		
100-80-125/120-110	86.0	100-65-200/189	69.6		
100-80-125/127	128.6	100-65-200/205	78.3		
100-80-125/137	137.3	100-65-200/219	85.0		
100-80-125/144	150.0	100-65-250/215	64.3		
100-80-160/143	123.0	100-65-250/232	72.0		
100-80-160/157	136.6	100-65-250/254	81.1		
100-80-160/173	153.6	100-65-250/270	89.0		
100-80-160/177	158.0	100-65-315/261	75.7		
100-65-200/162	110.5	100-65-315/282	87.2		
100-65-200/177	125.4	100-65-315/314	104.8		
100-65-200/190	136.5	100-65-315/320	110.0		
100-65-200/198	145.2	125-80-160/146	107.7		
100-65-200/217	163.0	125-80-160/161	117.4		
100-65-200/219	166.0	125-80-160/175	127.5		
100-65-250/223	134.4	125-80-160/177	130.0		
100-65-250/238	146.2	125-80-200/164	94.0		
100-65-250/251	157.2	125-80-200/179	106.0		
100-65-250/269	170.1	125-80-200/196	117.2		
100-65-250/270	174.0	125-80-200/214	132.3		
100-65-315/272	164.3	125-80-200/222	137.0		
100-65-315/295	190.2	125-80-250/225	111.0		
100-65-315/308	207.0	125-80-250/247	126.6		
100-65-315/320	225.0	125-80-250/270	144.0		
125-80-160/147-127	209.5	125-80-315/280	131.8		
125-80-160/151	233.0	125-80-315/305	154.1		
125-80-160/161	246.0	125-80-315/320	169.2		
125-80-160/167	256.4	125-80-315/334	180.0		
125-80-160/177	272.0	125-80-400/347	123.4		
125-80-200/171	202.4	125-80-400/365	134.7		
125-80-200/188	228.7	125-80-400/397	160.3		
125-80-200/200	251.1	125-80-400/419	174.7		
125-80-200/211	266.8	125-80-400/438	189.0		
125-80-200/222	286.0	125-100-160/160-144	141.1		
125-80-250/220	224.6	125-100-160/165	158.5		
125-80-250/234	244.1	125-100-160/176	175.0		
125-80-250/257	279.1	125-100-200/178	177.1		
125-80-250/270	300.0	125-100-200/195	191.8		
125-80-315/278	260.4	125-100-200/211	212.8		
125-80-315/295	285.4	125-100-200/219	225.0		
125-80-315/310	308.6	125-100-250/215	178.7		

2-pole: n = 2900 min <sup>-1</sup>		4-pole: n = 1450 min <sup>-1</sup>		6-pole: n = 970 min <sup>-1</sup>	
Pump type	Max. Q [m <sup>3</sup> /h]	Pump type	Max. Q [m <sup>3</sup> /h]	Pump type	Max. Q [m <sup>3</sup> /h]
125-80-315/328	338.1	125-100-250/245	200.5		
125-100-160/160-156	294.8	125-100-250/266	222.4		
125-100-160/169	334.8	125-100-250/270	236.0		
125-100-160/176	350.0	125-100-315/279	195.6		
125-100-200/170	309.1	125-100-315/295	211.3		
125-100-200/181	328.0	125-100-315/312	225.6		
125-100-200/192	345.7	125-100-315/334	248.0		
125-100-200/203	370.4	125-100-400/351	146.6		
125-100-200/219	410.0	125-100-400/387	166.7		
125-100-250/205	311.4	125-100-400/410	185.7		
125-100-250/229	355.9	125-100-400/432	210.3		
125-100-250/242	379.3	125-100-400/438	225.0		
125-100-250/258	409.0	150-125-200/188-180	243.1		
125-100-250/270	430.0	150-125-200/201	262.9		
125-100-315/269	369.2	150-125-200/221	289.7		
125-100-315/284	396.4	150-125-200/226	300.0		
125-100-315/301	428.5	150-125-250/220	296.4		
125-100-315/322	471.9	150-125-250/236	330.5		
150-125-200/188-174	486.0	150-125-250/249	362.0		
150-125-200/192	508.7	150-125-250/262	384.3		
150-125-200/209	548.2	150-125-250/269	400.0		
150-125-200/219	576.6	150-125-315/275	268.8		
150-125-200/226	600.0	150-125-315/290	287.0		
150-125-250/221	473.0	150-125-315/317	323.0		
150-125-250/235	508.6	150-125-315/336	355.2		
150-125-250/248	548.7	150-125-315/338	360.0		
150-125-250/261	595.0	150-125-400/345	270.5		
150-125-250/269	630.0	150-125-400/368	295.0		
150-125-315/262	521.2	150-125-400/392	322.8		
150-125-315/277	556.4	150-125-400/433	373.1		
150-125-315/297	607.0	150-125-400/438	380.0		
200-150-200/216-176	917.3	150-125-500/406	265.9		
200-150-200/218-202	949.6	150-125-500/447	307.6		
200-150-200/224	1000.0	150-125-500/473	335.2		
200-150-250/227	930.0	150-125-500/500	367.4		
200-150-250/241	976.8	150-125-500/526	406.7		
200-150-250/256	1028.4	150-125-500/548	463.0		
		200-150-200/210-160	433.3		
		200-150-200/218-208	475.3		
		200-150-200/224	500.0		
		200-150-250/226	494.3		
		200-150-250/238	524.0		
		200-150-250/251	541.8		
		200-150-250/271	588.7		
		200-150-250/284	621.7		
		200-150-250/286	625.0		
		200-150-315/275	593.6		
		200-150-315/291	635.7		
		200-150-315/310	695.2		
		200-150-315/336	787.8		
		200-150-315/338	800.0		
		200-150-400/343	519.3		
		200-150-400/375	585.4		
		200-150-400/394	630.7		
		200-150-400/412	690.3		
		200-150-400/431	757.6		

2-pole: $n = 2900 \text{ min}^{-1}$		4-pole: $n = 1450 \text{ min}^{-1}$		6-pole: $n = 970 \text{ min}^{-1}$	
Pump type	Max. Q [ $\text{m}^3/\text{h}$ ]	Pump type	Max. Q [ $\text{m}^3/\text{h}$ ]	Pump type	Max. Q [ $\text{m}^3/\text{h}$ ]
		200-150-400/438	780.0		
		200-150-500/459	541.8		
		200-150-500/489	583.1		
		200-150-500/521	643.6		

2-pole: n = 3500 min <sup>-1</sup>		4-pole: n = 1750 min <sup>-1</sup>		6-pole: n = 1170 min <sup>-1</sup>	
Pump type	Max. Q [m <sup>3</sup> /h]	Pump type	Max. Q [m <sup>3</sup> /h]	Pump type	Max. Q [m <sup>3</sup> /h]
50-32-125/97	29.8	50-32-125.1/116	11.0	125-100-160/160-154	111.7
50-32-125/107	32.1	50-32-125.1/132	12.9	125-100-160/168	127.6
50-32-125/122	37.4	50-32-125.1/140	14.0	125-100-160/176	140.0
50-32-125/130	40.0	50-32-160.1/147	12.1	125-100-200/169	128.9
50-32-125/142	44.0	50-32-160.1/164	14.3	125-100-200/185	144.3
50-32-125.1/95	18.2	50-32-160.1/177	16.0	125-100-200/198	156.2
50-32-125.1/104	20.5	50-32-200.1/168	12.9	125-100-200/214	173.4
50-32-125.1/116	23.6	50-32-200.1/185	14.7	125-100-200/219	180.0
50-32-125.1/129	26.8	50-32-200.1/202	16.6	125-100-250/216	145.6
50-32-125.1/140	30.0	50-32-200.1/207	17.0	125-100-250/238	162.3
50-32-160/128	29.3	50-32-125/109	16.7	125-100-250/261	183.1
50-32-160/139	33.2	50-32-125/123	18.9	125-100-250/270	190.0
50-32-160/152	38.1	50-32-125/140	21.5	125-100-315/276	156.4
50-32-160/168	42.2	50-32-125/142	22.0	125-100-315/310	179.5
50-32-160/177	47.0	50-32-160/131	14.5	125-100-315/334	199.0
50-32-160.1/133	19.6	50-32-160/147	17.2	125-100-400/343	126.3
50-32-160.1/145	22.6	50-32-160/162	19.8	125-100-400/379	143.4
50-32-160.1/156	25.6	50-32-160/177	23.0	125-100-400/404	159.0
50-32-160.1/170	29.1	50-32-200/174	16.0	125-100-400/424	176.2
50-32-160.1/177	31.0	50-32-200/189	18.7	125-100-400/438	199.0
50-32-200/164	30.4	50-32-200/204	21.3	150-125-200/188	196.4
50-32-200/179	34.7	50-32-200/219	24.0	150-125-200/204	210.8
50-32-200/197	40.8	50-32-250/198	13.2	150-125-200/222	229.3
50-32-200/212	46.8	50-32-250/218	15.2	150-125-200/226	240.0
50-32-200/219	49.0	50-32-250/243	17.6	150-125-250/219	237.2
50-32-200.1/158	23.2	50-32-250/262	19.0	150-125-250/234	265.0
50-32-200.1/175	26.4	65-50-125/111	28.5	150-125-250/261	307.4
50-32-200.1/192	29.7	65-50-125/123	31.4	150-125-250/269	322.0
50-32-200.1/207	32.0	65-50-125/137	34.0	150-125-315/254	210.1
50-32-250/207	26.9	65-50-125/142	36.0	150-125-315/286	243.7
50-32-250/227	30.6	65-50-160/128	25.3	150-125-315/313	274.4
50-32-250/242	33.2	65-50-160/143	28.6	150-125-315/333	300.7
50-32-250/256	35.3	65-50-160/155	32.1	150-125-315/338	310.0
50-32-250/262	36.0	65-50-160/170	35.9	150-125-400/346	215.4
65-50-125/110	51.0	65-50-160/177	38.0	150-125-400/367	233.1
65-50-125/118	59.3	65-40-200/169	28.3	150-125-400/404	268.1
65-50-125/131	61.4	65-40-200/184	32.1	150-125-400/432	295.2
65-50-125/140	69.7	65-40-200/205	37.4	150-125-400/438	304.0
65-50-125/142	71.0	65-40-200/219	41.0	150-125-500/446	244.1
65-50-160/131	52.4	65-40-250/207	31.9	150-125-500/470	266.5
65-50-160/143	57.9	65-40-250/225	35.1	150-125-500/501	294.1
65-50-160/162	66.9	65-40-250/246	38.9	150-125-500/543	354.9
65-50-160/177	74.0	65-40-250/260	43.0	150-125-500/548	370.0
65-40-200/178	58.7	65-40-315/284	30.1	200-150-200/210-170	365.5
65-40-200/193	66.6	65-40-315/313	33.9	200-150-200/218-212	376.4
65-40-200/206	72.7	65-40-315/344	38.0	200-150-200/224	401.0
65-40-200/216	77.8	80-65-125/109	45.9	200-150-250/250	404.7
65-40-200/219	79.0	80-65-125/120	51.2	200-150-250/271	441.3
65-40-250/193	60.0	80-65-125/132	57.5	200-150-250/286	466.0
65-40-250/206	64.8	80-65-125/144	62.0	200-150-315/283	410.5
65-40-250/215	69.3	80-65-160/134	47.7	200-150-315/297	437.3
65-40-250/236	76.8	80-65-160/146	52.7	200-150-315/323	495.4
65-40-250/252	83.0	80-65-160/165	60.5	200-150-315/338	533.0
80-65-125/105	70.0	80-65-160/177	66.0	200-150-400/327	341.9
80-65-125/113	93.3	80-50-200/178	51.3	200-150-400/358	386.8

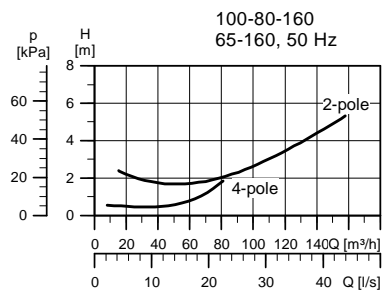
2-pole: n = 3500 min <sup>-1</sup>		4-pole: n = 1750 min <sup>-1</sup>		6-pole: n = 1170 min <sup>-1</sup>	
Pump type	Max. Q [m <sup>3</sup> /h]	Pump type	Max. Q [m <sup>3</sup> /h]	Pump type	Max. Q [m <sup>3</sup> /h]
80-65-125/124	103.8	80-50-200/193	58.8	200-150-400/380	418.5
65-50-125/131	61.4	65-40-200/184	32.1	150-125-400/432	295.2
65-50-125/140	69.7	65-40-200/205	37.4	150-125-400/438	304.0
65-50-125/142	71.0	65-40-200/219	41.0	150-125-500/446	244.1
65-50-160/131	52.4	65-40-250/207	31.9	150-125-500/470	266.5
65-50-160/143	57.9	65-40-250/225	35.1	150-125-500/501	294.1
65-50-160/162	66.9	65-40-250/246	38.9	150-125-500/543	354.9
65-50-160/177	74.0	65-40-250/260	43.0	150-125-500/548	370.0
65-40-200/178	58.7	65-40-315/284	30.1	200-150-200/210-170	365.5
65-40-200/193	66.6	65-40-315/313	33.9	200-150-200/218-212	376.4
65-40-200/206	72.7	65-40-315/344	38.0	200-150-200/224	401.0
65-40-200/216	77.8	80-65-125/109	45.9	200-150-250/250	404.7
65-40-200/219	79.0	80-65-125/120	51.2	200-150-250/271	441.3
65-40-250/193	60.0	80-65-125/132	57.5	200-150-250/286	466.0
65-40-250/206	64.8	80-65-125/144	62.0	200-150-315/283	410.5
65-40-250/215	69.3	80-65-160/134	47.7	200-150-315/297	437.3
65-40-250/236	76.8	80-65-160/146	52.7	200-150-315/323	495.4
65-40-250/252	83.0	80-65-160/165	60.5	200-150-315/338	533.0
80-65-125/105	70.0	80-65-160/177	66.0	200-150-400/327	341.9
80-65-125/113	93.3	80-50-200/178	51.3	200-150-400/358	386.8
80-65-125/124	103.8	80-50-200/193	58.8	200-150-400/380	418.5
80-65-125/140	116.7	80-50-200/210	67.1	200-150-400/398	455.2
80-65-125/144	120.0	80-50-200/219	70.0	200-150-400/419	502.5
80-65-160/127	85.3	80-50-250/221	55.2	200-150-400/438	550.0
80-65-160/141	96.8	80-50-250/244	64.5	200-150-500/433	394.4
80-65-160/154	107.9	80-50-250/263	73.0	200-150-500/482	447.1
80-65-160/165	117.3	80-50-315/256	40.6	200-150-500/510	478.6
80-65-160/177	126.0	80-50-315/283	46.3	200-150-500/534	535.3
80-50-200/167	92.5	80-50-315/314	53.7	200-150-500/548	566.0
80-50-200/178	99.5	80-50-315/344	60.0		
80-50-200/187	107.4	100-80-125/124	78.1		
80-50-200/205	121.8	100-80-125/136	84.0		
80-50-200/218	130.8	100-80-125/144	92.0		
80-50-250/213	107.4	100-80-160/141	74.2		
80-50-250/229	113.9	100-80-160/156	83.2		
100-80-125/120-110	148.2	100-80-160/169	91.7		
100-80-125/130	157.9	100-80-160/177	97.0		
100-80-125/141	174.0	100-65-200/174	75.9		
100-80-125/144	180.0	100-65-200/189	84.8		
100-80-160/136	137.4	100-65-200/209	95.6		
100-80-160/147	154.9	100-65-200/219	102.0		
100-80-160/155	163.1	100-65-250/215	78.2		
100-80-160/163	173.8	100-65-250/238	88.8		
100-80-160/177	190.0	100-65-250/265	102.6		
100-65-200/160	132.0	100-65-250/270	107.0		
100-65-200/168	140.1	100-65-315/242	80.4		
100-65-200/184	158.4	100-65-315/270	96.5		
100-65-200/195	171.2	100-65-315/290	111.1		
100-65-250/212	151.2	100-65-315/305	121.7		
100-65-250/226	164.4	100-65-315/320	132.0		
100-65-250/248	185.4	125-80-160/150	134.4		
100-65-250/263	199.2	125-80-160/161	143.3		
100-65-250/270	209.0	125-80-160/177	156.0		
125-80-160/150-130	263.4	125-80-200/167	109.7		
125-80-160/156	286.6	125-80-200/184	124.5		
125-80-160/165	302.1	125-80-200/202	139.3		



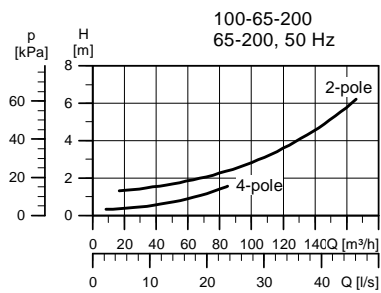
2-pole: n = 3500 min <sup>-1</sup>		4-pole: n = 1750 min <sup>-1</sup>		6-pole: n = 1170 min <sup>-1</sup>	
Pump type	Max. Q [m <sup>3</sup> /h]	Pump type	Max. Q [m <sup>3</sup> /h]	Pump type	Max. Q [m <sup>3</sup> /h]
125-80-200/169	244.3	125-80-200/222	164.0		
125-80-200/179	262.4	125-80-250/211	118.5		
125-80-200/192	288.0	125-80-250/234	138.6		
125-80-200/207	324.0	125-80-250/255	158.2		
125-80-200/222	343.0	125-80-250/270	173.0		
125-80-250/218	267.2	125-80-315/275	155.9		
125-80-250/230	287.7	125-80-315/287	167.5		
125-80-250/244	311.1	125-80-315/314	195.2		
125-80-250/259	338.0	125-80-315/332	213.7		
125-80-250/270	360.0	125-80-315/334	216.0		
125-100-160/160-154	348.2	125-80-400/342	143.3		
125-100-200/173	380.2	125-80-400/362	158.6		
125-100-200/192	415.5	125-80-400/380	175.1		
125-100-200/201	439.0	125-80-400/401	197.1		
125-100-200/212	470.8	125-80-400/437	222.7		
125-100-200/219	492.0	125-80-400/438	227.0		
125-100-250/217	405.4	125-100-160/160-146	171.3		
125-100-250/231	427.5	125-100-160/165	193.6		
125-100-250/243	455.8	125-100-160/176	210.0		
125-100-250/261	495.1	125-100-200/166	195.0		
150-125-200/188-168	498.4	125-100-200/182	213.1		
150-125-200/188	520.8	125-100-200/201	236.6		
150-125-200/200	552.4	125-100-200/217	264.3		
150-125-200/211	578.1	125-100-200/219	270.0		
150-125-200/223	613.2	125-100-250/223	225.4		
150-125-200/226	625.0	125-100-250/236	242.2		
150-125-250/226	495.1	125-100-250/249	257.1		
150-125-250/242	540.6	125-100-250/270	283.0		
200-150-200/210-154	865.5	125-100-315/264	213.3		
200-150-200/216-176	920.0	125-100-315/290	241.0		
200-150-200/218-204	950.1	125-100-315/309	260.2		
200-150-200/224	1000.0	125-100-315/329	281.7		
		125-100-315/334	298.0		
		125-100-400/347	172.9		
		125-100-400/367	186.7		
		125-100-400/392	204.5		
		125-100-400/428	244.8		
		125-100-400/438	270.0		
		150-125-200/191	303.5		
		150-125-200/208	326.2		
		150-125-200/218	343.7		
		150-125-200/226	360.0		
		150-125-250/214	351.5		
		150-125-250/224	373.8		
		150-125-250/243	417.0		
		150-125-250/269	480.0		
		150-125-315/271	315.0		
		150-125-315/287	339.0		
		150-125-315/303	364.6		
		150-125-315/320	393.9		
		150-125-315/338	430.0		
		150-125-400/333	283.8		
		150-125-400/369	325.5		
		150-125-400/389	352.9		
		150-125-400/414	388.0		
		150-125-400/438	420.0		

2-pole: n = 3500 min <sup>-1</sup>		4-pole: n = 1750 min <sup>-1</sup>		6-pole: n = 1170 min <sup>-1</sup>	
Pump type	Max. Q [m <sup>3</sup> /h]	Pump type	Max. Q [m <sup>3</sup> /h]	Pump type	Max. Q [m <sup>3</sup> /h]
		150-125-500/423	338.1		
		150-125-500/447	367.5		
		150-125-500/474	401.8		
		150-125-500/508	449.0		
		200-150-200/214-174	540.1		
		200-150-200/218-202	567.1		
		200-150-200/222	590.0		
		200-150-250/234	580.8		
		200-150-250/248	600.8		
		200-150-250/260	631.9		
		200-150-250/273	668.5		
		200-150-250/286	700.0		
		200-150-315/269	579.8		
		200-150-315/295	647.2		
		200-150-315/309	695.3		
		200-150-315/326	755.1		
		200-150-315/338	800.0		
		200-150-400/341	549.0		
		200-150-400/361	593.0		
		200-150-400/381	636.7		
		200-150-400/401	693.9		
		200-150-400/424	774.4		
		200-150-500/419	706.6		

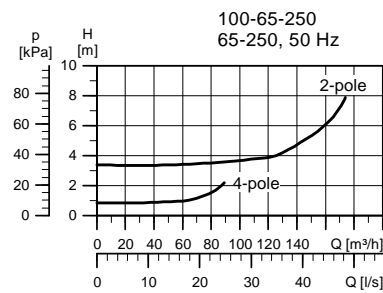




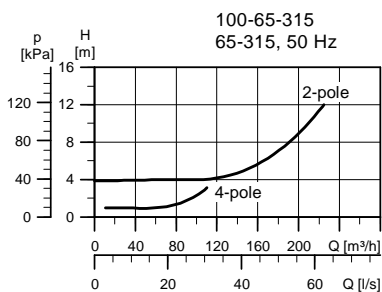
TM03 6073 4306



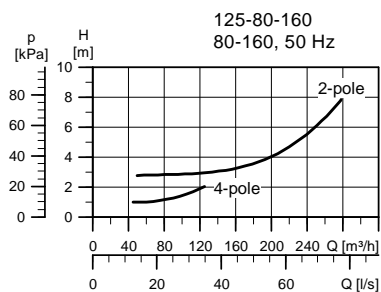
TM03 6074 4306



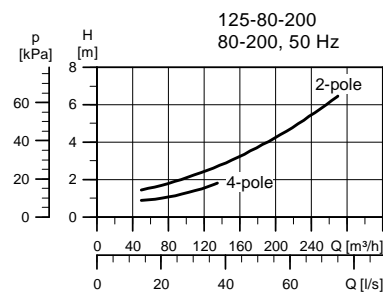
TM03 6075 4306



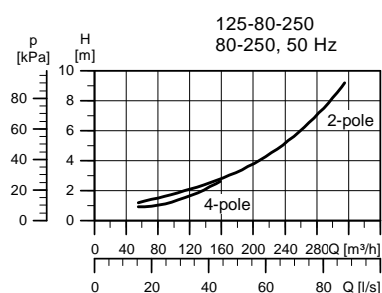
TM03 6076 4306



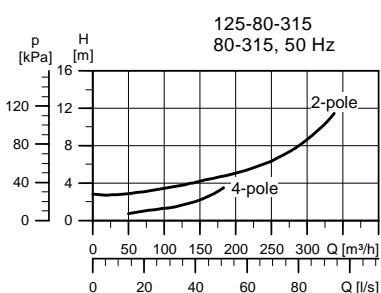
TM03 6077 4306



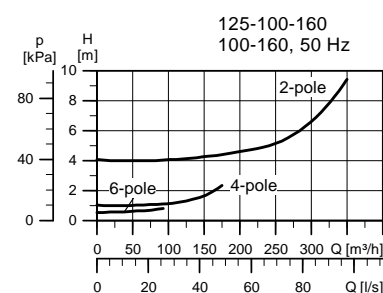
TM03 6078 4306



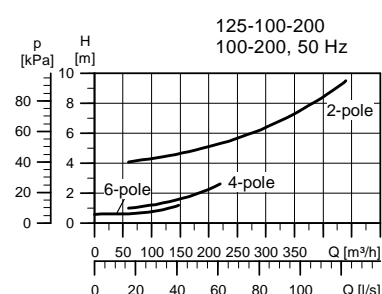
TM03 6079 4306



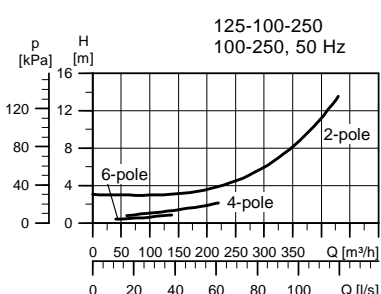
TM03 6080 4306



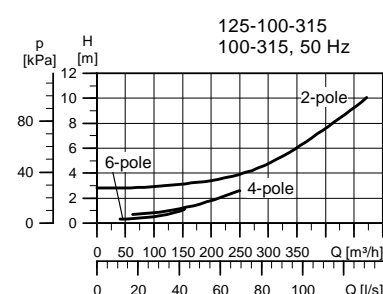
TM03 6082 4306



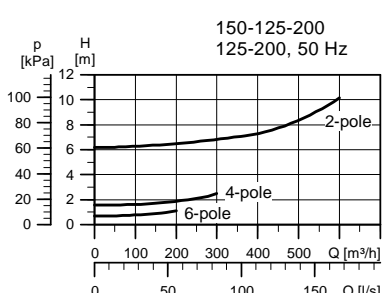
TM03 6082 4306



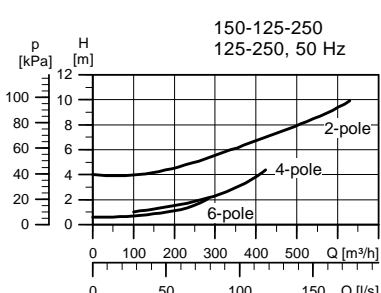
TM03 3683 4306



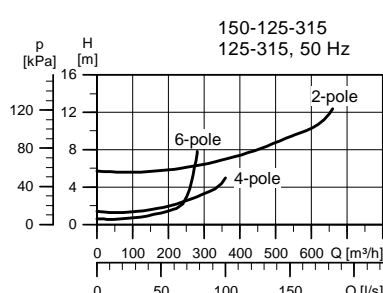
TM03 6084 4306



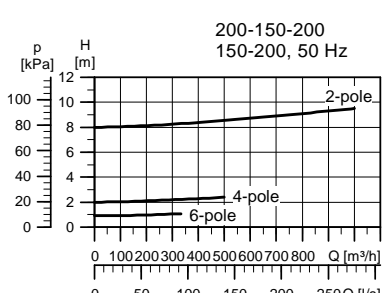
TM03 6085 4306



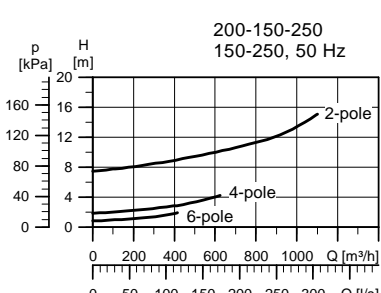
TM03 6086 4306



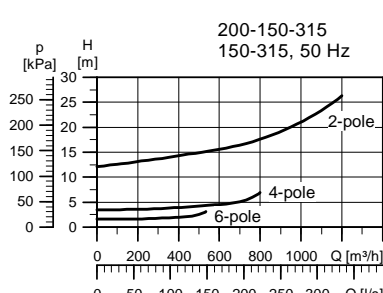
TM03 6087 4306



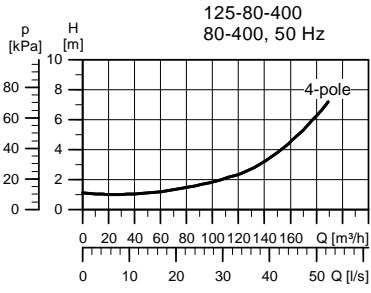
TM03 6088 4306



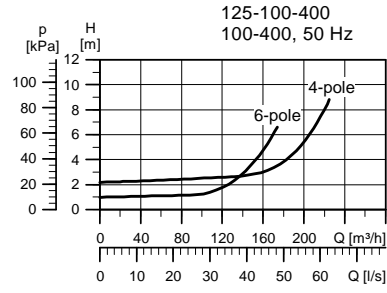
TM03 6089 4306



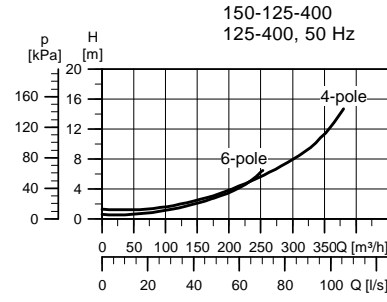
TM03 6090 4306



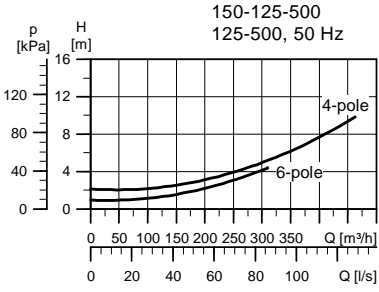
TM03 6136 4306



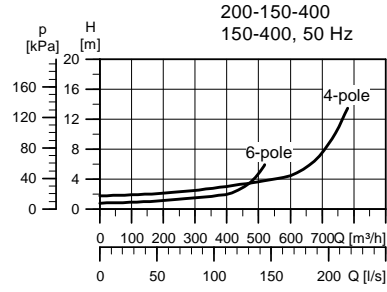
TM03 6137 4306



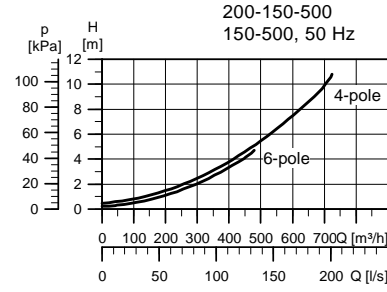
TM03 6138 4306



TM03 6139 4306

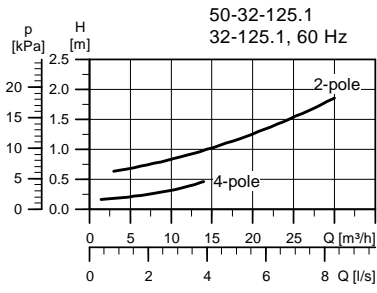


TM03 6131 4306

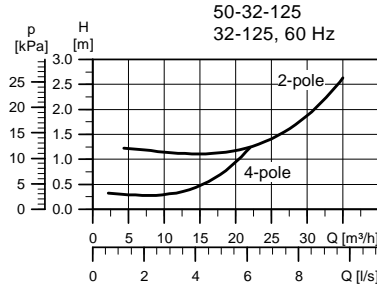


TM03 6132 4306

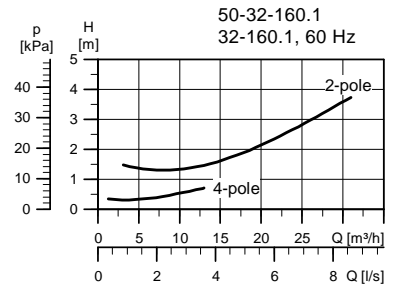
60 Hz



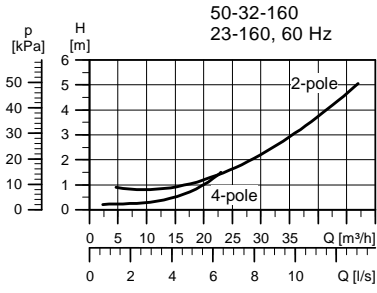
TM03 6092 4306



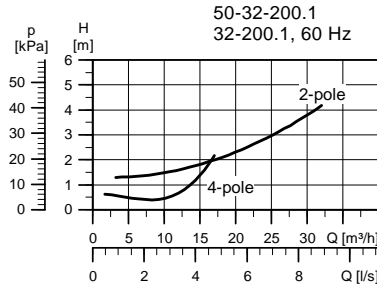
TM03 6091 4306



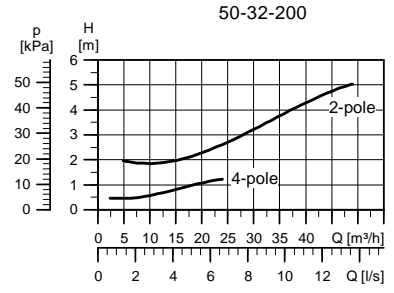
TM03 6094 4306



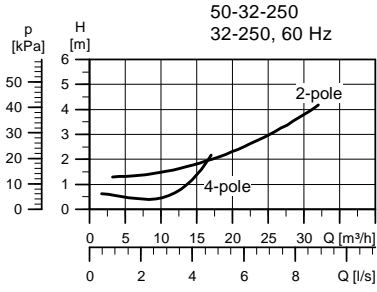
TM03 6093 4306



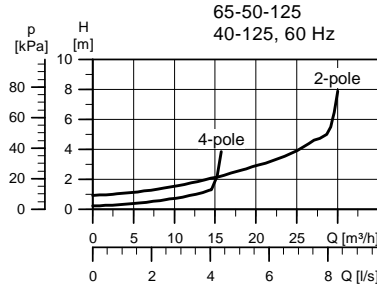
TM03 6096 4306



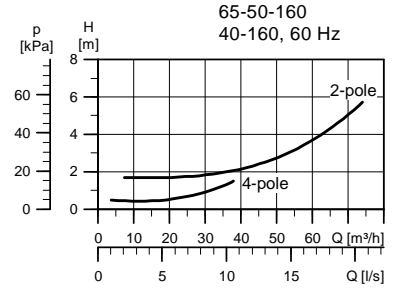
TM03 6095 4306



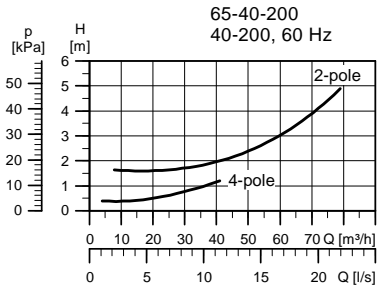
TM03 6097 4306



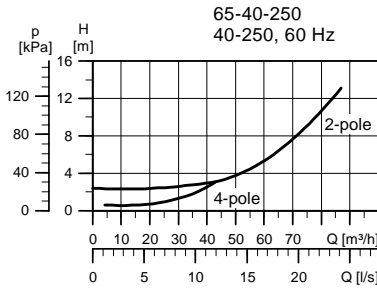
TM03 6098 4306



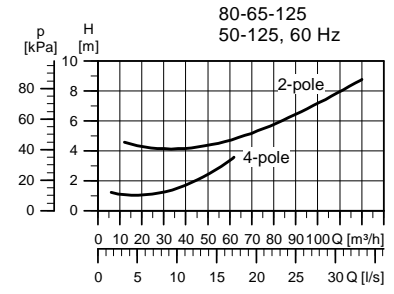
TM03 6099 4306



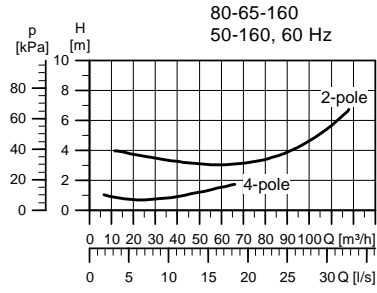
TM03 6100 4306



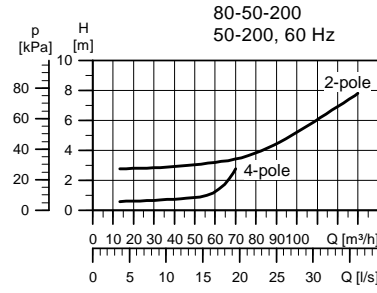
TM03 6101 4306



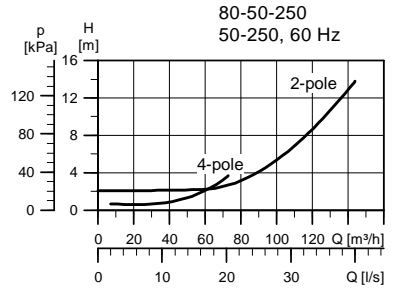
TM03 6102 4306



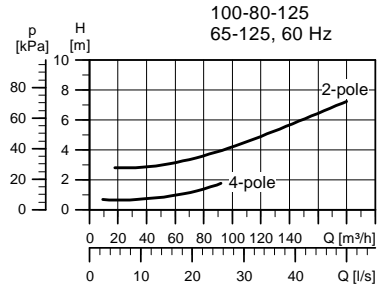
TM03 6103 4306



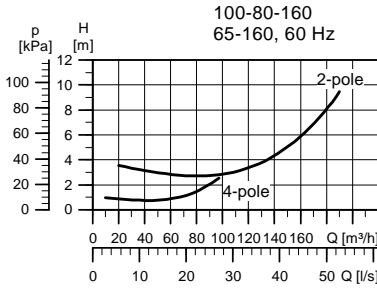
TM03 6104 4306



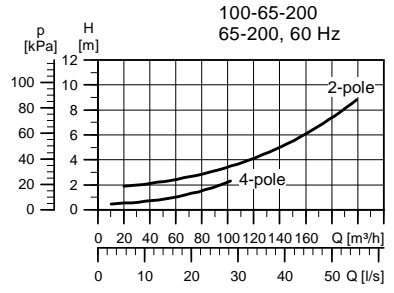
TM03 6105 4306



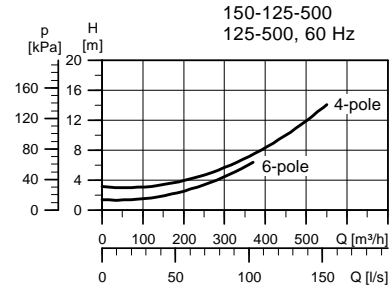
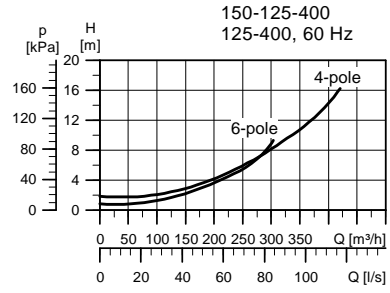
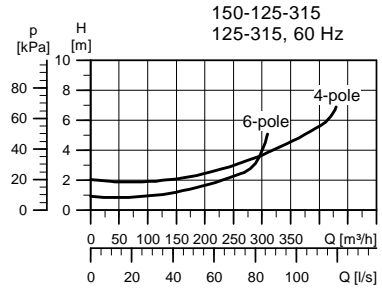
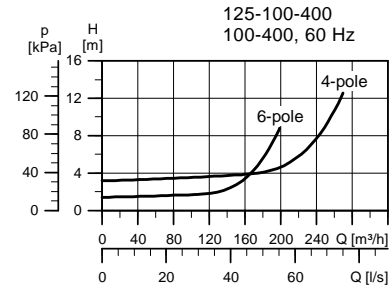
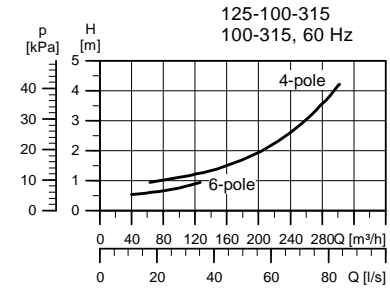
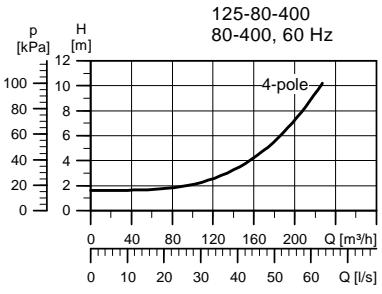
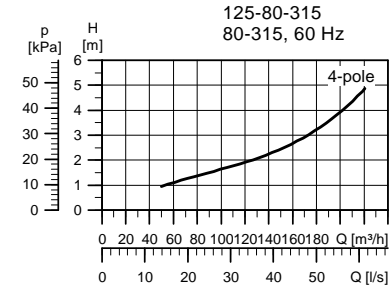
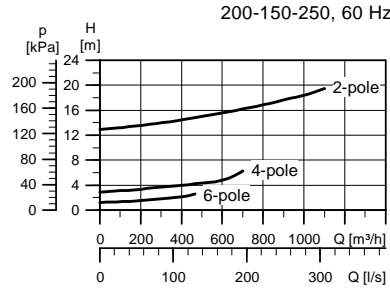
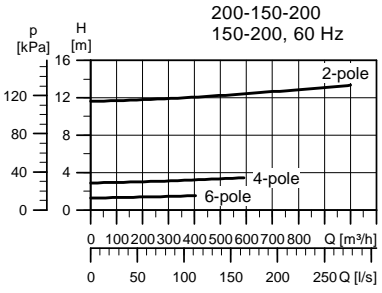
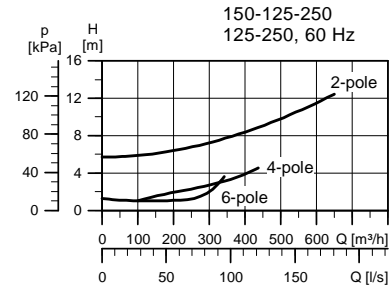
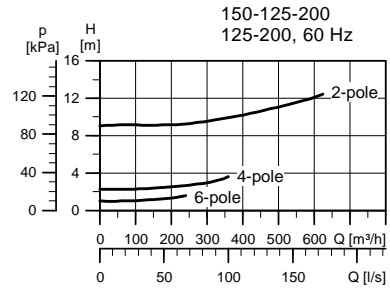
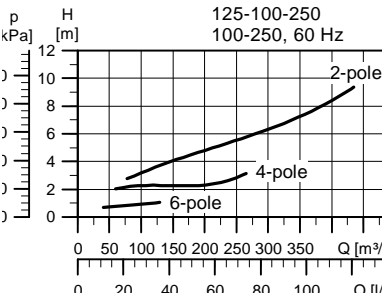
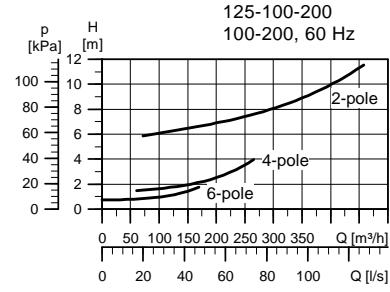
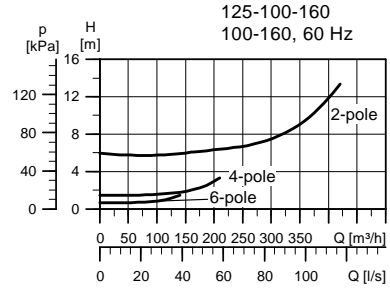
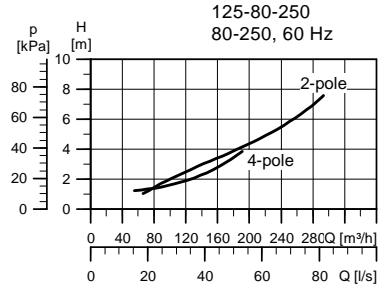
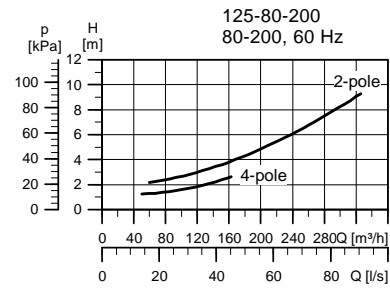
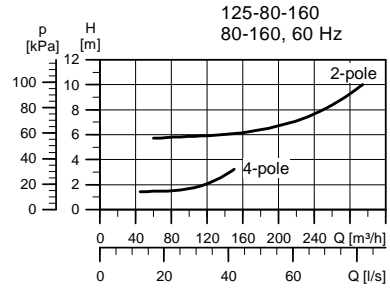
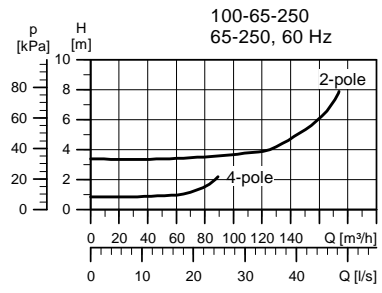
TM03 6106 4306

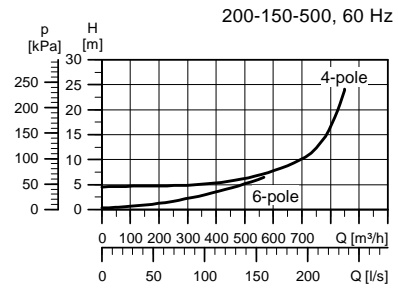
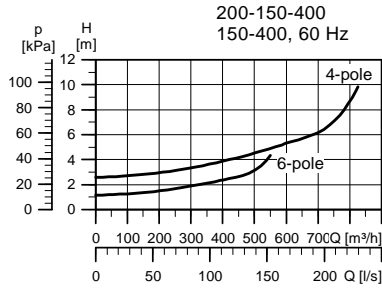
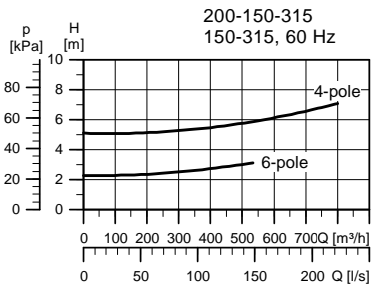


TM03 6107 4306



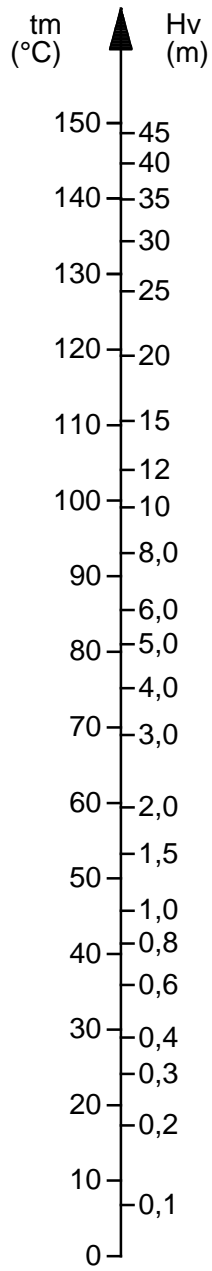
TM03 6108 4306







Vapour pressure in metres head



TMOO 3037 0798



<b>96483177</b> 0310	<b>185</b>
Repl. 96483177 1209	