

motralec

4 rue Lavoisier . ZA Lavoisier . 95223 HERBLAY CEDEX

Tel. : 01.39.97.65.10 / Fax. : 01.39.97.68.48

Demande de prix / e-mail : service-commercial@motralec.com

www.motralec.com

SPK, MTH, CRK

Immersible pumps
50/60 Hz



Contents

General data

Performance range	Page	3
Product range	Page	4

SPK

SPK, 50 Hz	Page	6
Performance range	Page	6
Product range	Page	6
SPK, 60 Hz	Page	7
Performance range	Page	7
Product range	Page	7
Performance curves	Page	14
SPK 1, 50 Hz	Page	14
SPK 2, 50 Hz	Page	16
SPK 4, 50 Hz	Page	18
SPK 8, 50 Hz	Page	20
Performance curves	Page	22
SPK 1, 60 Hz	Page	22
SPK 2, 60 Hz	Page	24
SPK 4, 60 Hz	Page	26
SPK 8, 60 Hz	Page	28

MTH, 50 Hz

MTH, 50 Hz	Page	30
Performance range	Page	30
Product range	Page	30
MTH, 60 Hz	Page	31
Performance range	Page	31
Product range	Page	31
Performance curves	Page	38
MTH 8, 50 Hz	Page	38
MTH 12, 50 Hz	Page	40
MTH 16, 50 Hz	Page	42
Performance curves	Page	44
MTH 8, 60 Hz	Page	44
MTH 12, 60 Hz	Page	46
MTH 16, 50 Hz	Page	48

CRK, 50 Hz

CRK, 50 Hz	Page	50
Performance range	Page	50
Product range	Page	50
CRK, 60 Hz	Page	52
Performance range	Page	52
Product range	Page	52
Performance curves	Page	60
CRK 2, 50 Hz	Page	60
CRK 4, 50 Hz	Page	62
CRK 8, 50 Hz	Page	64
CRK 16, 50 Hz	Page	66
Performance curves	Page	68
CRK 2, 60 Hz	Page	68
CRK 4, 60 Hz	Page	70
CRK 8, 60 Hz	Page	72
CRK 16, 60 Hz	Page	74

Application photos

SPK, MTH, CRK	Page	76
---------------	------	----

Performance range

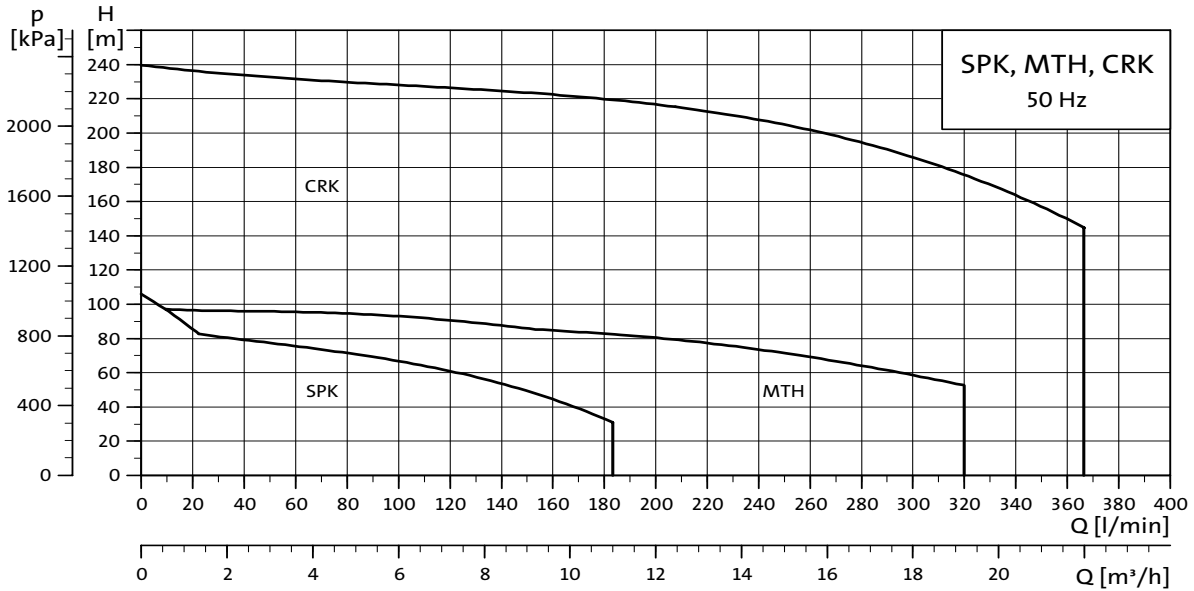

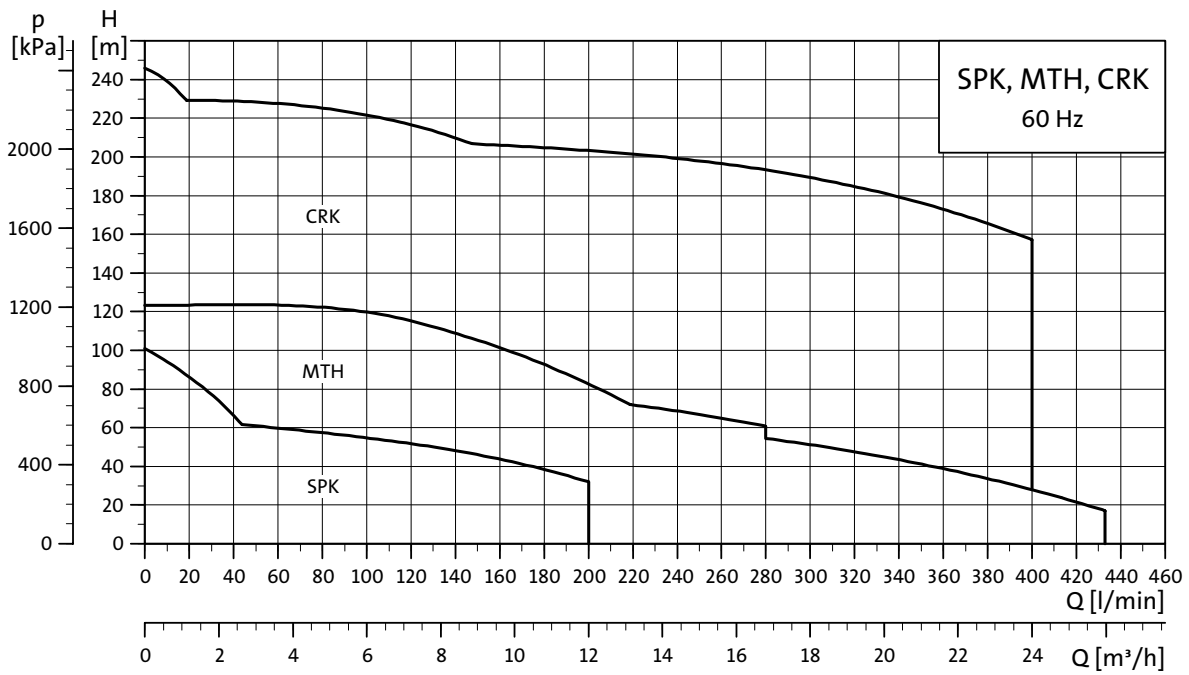

TM02.9393 2504



TM02.9394 2504

Product range

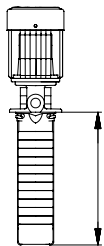
	 TM01 6168 1699				 TM01 6012 1599			
Description	SPK 1	SPK 2	SPK 4	SPK 8	MTH 8	MTH 12	MTH 16	
Range 50 Hz								
Nominal flow [m³/h]	1	2	4	8	8	12	16	
Nominal flow [l/min]	16.7	33.3	67	133	133	200	267	
Flow range [m³/h]	0.2-1.5	0.5-2.5	2.0-5.0	4.0-11	4.8-12	7.2-14.4	8.4-19.2	
Flow range [l/min]	3.3-25	8.3-41.7	33.3-83	67-180	80-200	120-240	140-320	
Maximum head [bar]	8.6	10.5	9.8	8.5	8.5	9.5	7.5	
Motor power [kW]	0.06-0.55	0.06-0.75	0.06-1.1	0.25-2.2	1.1-3.2	2.2-5.5	2.5-5.2	
Liquid temperature range [°C]	-10 to +90	-10 to +90	-10 to +90	-10 to +90	-10 to +90	-10 to +90	-10 to +90	
Maximum efficiency [%]	40	55	50	58	53	48	52	
Range 60 Hz								
Nominal flow [m³/h]	1	2	4	8	8	12	16	
Nominal flow [l/min]	16.7	33.3	67	133	133	200	267	
Flow range [m³/h]	0.2-1.8	0.6-3.0	2.0-6.0	4.5-12	5.4-13.2	9.6-16.8	10.8-26	
Flow range [l/min]	3.3-30	10.0-50	33.3-100	75-200	90-220	160-280	180-433	
Maximum head [bar]	8.5	10.0	7.5	6.5	12	8.5	7.0	
Motor power [kW]	0.06-0.55	0.06-1.1	0.12-1.1	0.37-2.2	1.8-5.3	3.3-5.7	3.5-5.4	
Liquid temperature range [°C]	-10 to +90	-10 to +90	-10 to +90	-10 to +90	-10 to +90	-10 to +90	-10 to +90	
Maximum efficiency [%]	40	55	50	58	40	51	52	
Material variants								
Motor stool/pump head: Cast iron# DIN W.-Nr. 0.6020, ASTM 25B	
(I-version) Motor stool/pump head:# Stainless steel: # DIN W.-Nr. 1.4408, AISI 316LN	
Pipe connection								
Rp ¾	
Rp 1¼	
Special flange (rectangular)	
Installation length [mm]								
	50Hz	140-1005	140-1005	140-1005	140-1005	60-210	60-210	75-255
	60Hz	140-1005	140-1005	140-1005	140-1005	60-210	60-210	75-255
Shaft seal								
CVBV	
AUUV	
Miscellaneous features								
Impeller locked by spline	
Impeller locked by split cone	
Variable-speed motor (0.75 kW) ^a	
Multi-plug [#]	

^a On request

Product range



TM01 61671699

Description	CRK 2	CRK 4	CRK 8	CRK 16	
Range 50 Hz					
Nominal flow [m ³ /h]	2	4	8	16	
Nominal flow [l/min]	33.3	67	133	267	
Flow range [m ³ /h]	1.0-3.5	2.0-8.0	6.0-12	8.0-22	
Flow range [l/min]	16.7-58	33.3-133	100-200	133-367	
Maximum head [bar]	24	21.8	22	23.8	
Motor power [kW]	0.37-3.0	0.37-4.0	0.75-7.5	1.1-15	
Liquid temperature range [°C]	-10 to +90	-10 to +90	-10 to +90	-10 to +90	
Maximum efficiency [%]	45	60	65	70	
Range 60 Hz					
Nominal flow [m ³ /h]	2	4	8	16	
Nominal flow [l/min]	33.3	67	133	267	
Flow range [m ³ /h]	1.0-4.5	2.6-9.0	7.0-14.5	10.0-26	
Flow range [l/min]	16.7-75	43.3-150	117-242	167-433	
Maximum head [bar]	24	17	22.5	21.5	
Motor power [kW]	0.37-4.0	0.75-4.0	1.5-11	1.5-15	
Liquid temperature range [°C]	-10 to +90	-10 to +90	-10 to +90	-10 to +90	
Maximum efficiency [%]	45	60	65	70	
Material variants					
Motor stool/pump head: Cast iron# DIN W.-Nr. 0.6020, ASTM 25B	
(I-version) Motor stool/pump head:# Stainless steel: # DIN W.-Nr. 1.4408, AISI 316LN	
Pipe connection					
Rp 1½	
Rp 2	
DN65	
DN80	
Special flange (rectangular)	
Installation length [mm]					
	50Hz	160-1005	169-1005	148-688	178-808
	60Hz	160-1005	169-1005	148-688	178-808
Shaft seal					
AUUV	
BUBV	
EUUV	
Miscellaneous features					
Impeller locked by spline	
Impeller locked by split cone	
Variable-speed motor (≤7.5 kW) [#]	
Multi-plug [#]	

[#] On request

SPK, 50 Hz

Performance range

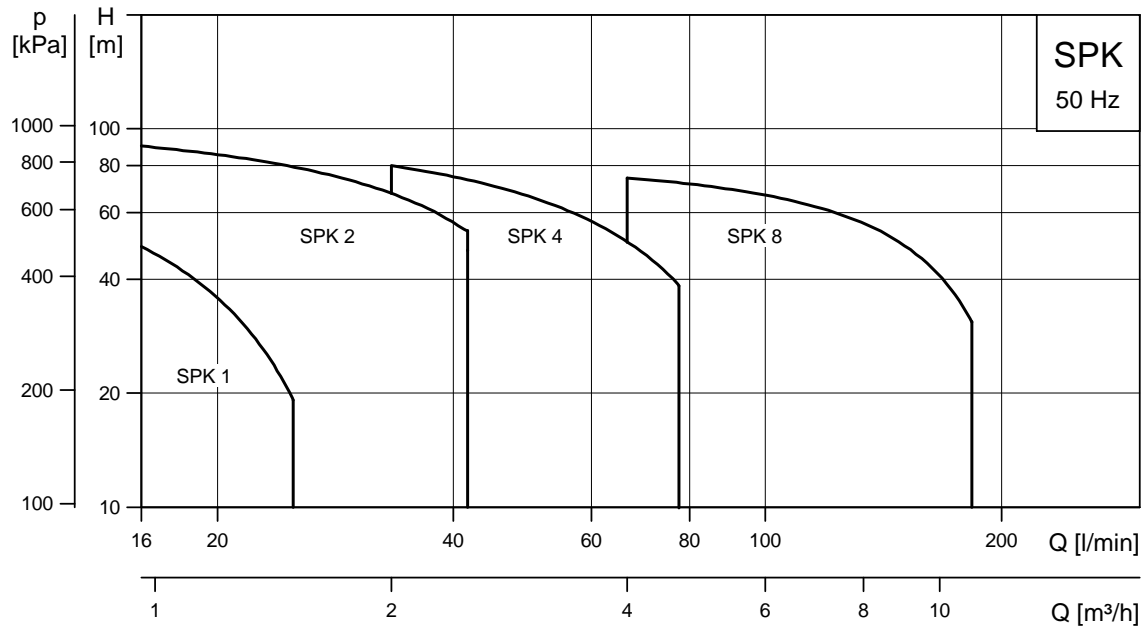

TM00 8398 0599

Product range

SPK 1

Example: SPK 1-8/8	Number of impellers								B [mm]
	1	3	5	8	11	15	19	23	
1	140
3	182
5	224
8	287
11	350
15	434
19	518
23	602
23 ^a	1005
Motor [kW]	0.06	0.06	0.12	0.18	0.25	0.37	0.37	0.55	

^a with extension pipe.

SPK 2

Example: SPK 2-8/8	Number of impellers								B [mm]
	1	3	5	8	11	15	19	23	
1	140
3	182
5	224
8	287
11	350
15	434
19	518
23	602
23 ^a	1005
Motor [kW]	0.06	0.12	0.18	0.37	0.37	0.55	0.75	0.75	

^a with extension pipe.

SPK 4

Example: SPK 4-8/8	Number of impellers								B [mm]
	1	3	5	8	11	15	19		
1	140
3	182
5	224
8	287
11	350
15	434
19	518
19 ^a	1005
Motor [kW]	0.06	0.18	0.37	0.55	0.75	1.1	1.1		

^a with extension pipe.

SPK 8

Example: SPK 8-7/7	Number of impellers										B [mm]
	1	2	3	5	7	9	12	15			
1	182
2	224
3	266
5	350
7	434
9	518
12	644
15	770
15 ^a	1005
Motor [kW]	0.25	0.37	0.55	0.75	1.1	1.5	2.2	2.2			

^a with extension pipe.

SPK, 60 Hz

Performance range

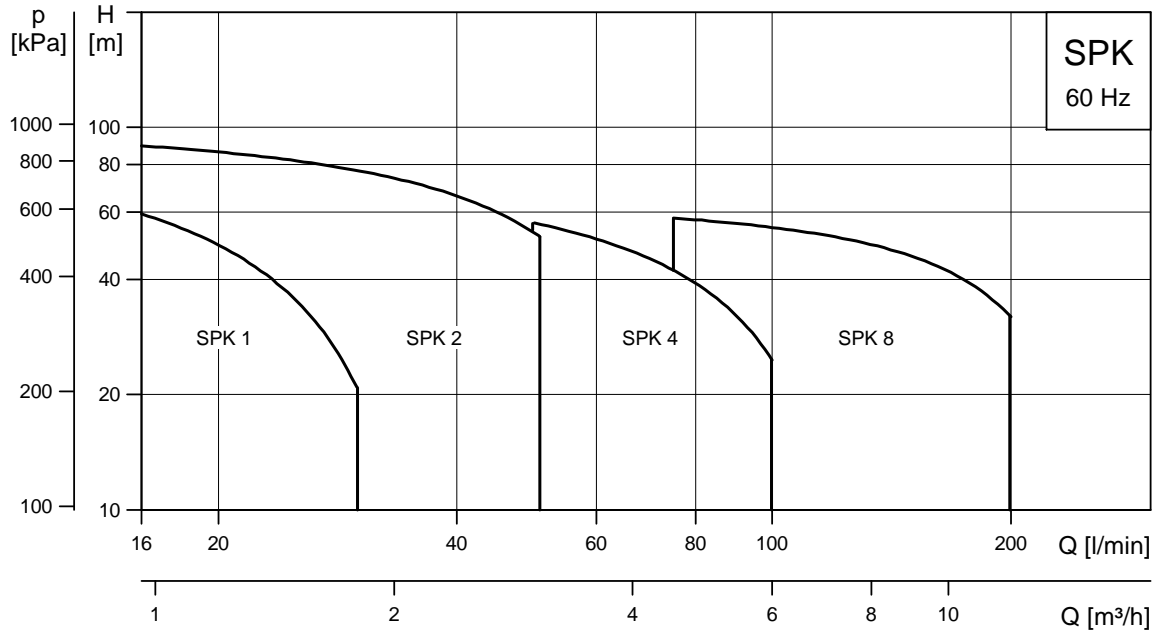

TM00 8397 0599

Product range

SPK 1

Example: SPK 1-8/8	Number of impellers						B [mm]
	1	3	5	8	11	15	
1	140
3	182
5	224
8	287
11	350
15	434
19	518
23	602
23 ^a	1005
Motor [kW]	0.06	0.12	0.18	0.25	0.37	0.55	

^a with extension pipe.

SPK 2

Example: SPK 2-8/8	Number of impellers						B [mm]
	1	3	5	8	11	15	
1	140
3	182
5	224
8	287
11	350
15	434
19	518
23	602
23 ^a	1005
Motor [kW]	0.06	0.18	0.37	0.55	0.75	1.1	

^a with extension pipe.

SPK 4

Example: SPK 4-8/8	Number of impellers						B [mm]
	1	3	5	8	10	10	
1	140
3	182
5	224
8	287
11	350
15	434
19	518
19 ^a	1005
Motor [kW]	0.12	0.37	0.55	1.1	1.1		

^a with extension pipe.

SPK 8

Example: SPK 8-7/7	Number of impellers							B [mm]
	1	2	3	5	7	8	8	
1	182
2	224
3	266
5	350
7	434
9	518
12	644
15	770
15 ^a	1005
Motor [kW]	0.37	0.55	1.1	1.5	2.2	2.2		

^a with extension pipe.

Product description

SPK is designed for pumping cooling lubricants for machine tools, condensate transfer and other purposes. # The pump is designed for low to medium pressure and is very flexible as to installation length. #

SPK can be used for applications involving spark machine tools, grinding machines, machining centres, cooling units, industrial washing machines, filtering systems etc.

Pumped liquids

Thin, clean, non-explosive liquids without abrasive particles or fibres. Both water and water-soluble coolants and cutting lubricants can be pumped.

Pump

The pump is a multistage, centrifugal pump with mechanical shaft seal according to DIN 24960. Mounting flange sizes according to DIN 5440. To meet specific depths of tanks or containers, the installation length of the pump can be varied using empty chambers. # Available variants are based on the number of stages indicated in the Dimensions and weights tables. Example: An SPK 1 pump with 8 impellers is available with installation lengths from SPK 1-8 to SPK 1-23 (dimension B). #

Note: Empty chambers may cause pressure loss.

I-version

As standard the SPK pumps are available as I-version called SPKI. All parts of SPKI pumps in contact with the pumped liquid are made of stainless steel (DIN W.-Nr 1.4401 or 1.4408, AISI 316 or 316LN).

Special pipe connection

All SPK pumps are available with a special rectangular flange. This flange facilitates installation. Pumps with the special rectangular flange are supplied with a rectangular counter flange, see figure below.

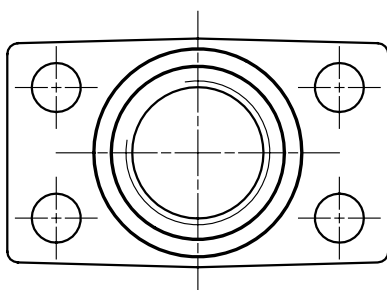

TM011915.1099

Motor

The pump is fitted with a totally enclosed, fan-cooled standard motor with principal dimensions according to IEC, DIN and British standards.

Enclosure class :	IP 54#
Insulation class :	F#
Standard voltages, 50 Hz :	1 x 220 - 230/240 V#
	3 x 200/346 V#
	3 x 220 - 240/380 - 415 V#
	3 x 220 - 255/380 - 440 V#
Standard voltages, 60 Hz :	3 x 200 - 230/346 - 400 V#
	3 x 220 - 255/380 - 440 V#
	3 x 220 - 277/380 - 480 V.

Other voltages available on request.

SPK is also available with variable speed motors, type MGE:

MGE single phase:	0.25 - 1.1 kW#
MGE three phase:	0.75 - 7.5 kW.

Max. ambient temperature

Due to the low density and consequently low cooling effect of the air, operation at an ambient temperature above 40°C or at an altitude exceeding 1000 m above sea level requires a reduction of P2.

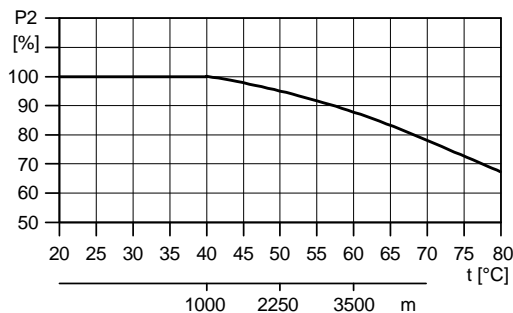

TM00 2189 4298

Example:#

From the above figure appears that P2 must be reduced to 88% when the pump is installed 3500 m above sea level. At an ambient temperature of 70°C, P2 must be reduced to 80% of rated output.

Sound pressure level

Motor [kW]	\bar{L}_{pA} [dB(A)]	
	50 Hz	60 Hz
0.06	<70	<70
0.12	<70	<70
0.18	<70	<70
0.25	<70	<70
0.37	<70	<70
0.55	<70	<70
0.75	<70	<70
1.1	<70	<70
1.5	<70	71
2.2	<70	71

Shaft seal

Max. operating pressure and liquid temperature

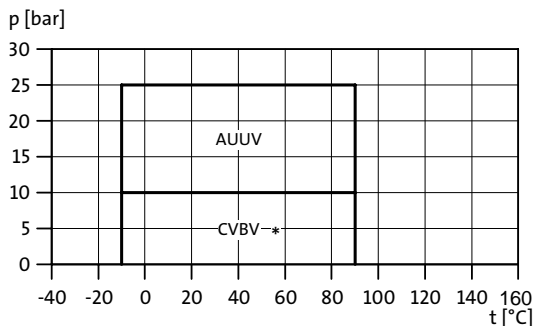

TM03 0022 3804

^a CVBV available on request.

Type key

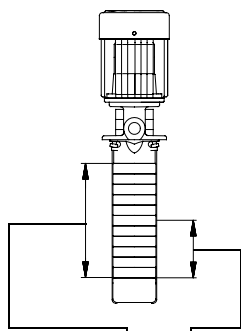

Example	SPK	2 - 15	/	8	A - W - A	AUUV
Pump type						
Nominal flow [m ³ /h]						
No. of chambers						
Number of impellers# (ref. to performance curve # and motor size)						
Pump version#						
A : Basic						
L : With extension pipe						
Connection code						
Materials#						
A : Basic						
I : Motor stool in stainless steel						
Shaft seal						

Extension pipe

All SPK pumps are available with an extension pipe. The extension pipe is available in various lengths enabling installation lengths up to 1005 mm possible.

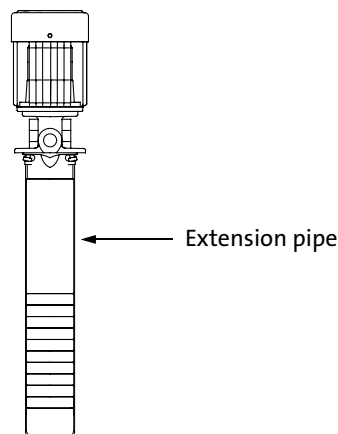

TM01 4214 1299

Installation

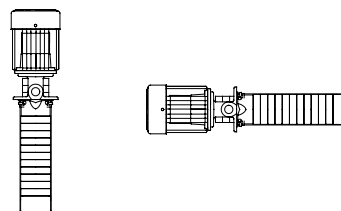

TM00 1922 3297

If the SPK pump is installed horizontally, the motor stool drain hole must be closed.

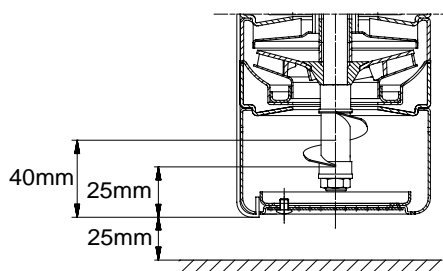

TM01 1204 3801

To enable a very low liquid level of 40 mm above the bottom of the strainer, a priming screw is fitted below the bottom intermediate chamber. # This protects the pump against dry running down to 25 mm above the bottom of the strainer.

Distance between pump and tank bottom must be minimum 25 mm.

Materials

Pos.	Description	Materials	DIN W.-Nr.	AISI/ASTM
Motor stool				
2	Motor stool# (no drain hole for central europe)	Cast iron # EN-GJL-200	0.6020	ASTM 25B
		Stainless steel# (I-version)	1.4408	AISI 316LN
7	Coupling guard	Stainless steel	1.4301	AISI 304
7a	Screw	Stainless steel		
28	Set screw	Stainless steel		
76	Nameplate	Stainless steel		
	Extension pipe	Stainless steel	1.4301	AISI 304
Intermediate chamber without bearing				
3	Intermediate chamber	Stainless steel	1.4301	AISI 304
3a	Intermediate chamber	Stainless steel	1.4301	AISI 304
4	Intermediate chamber	Stainless steel	1.4301	AISI 304
45	Neck ring	Tin/bronze # (only SPK 8)	2.1020.10.	
45	Neck ring	PPS 40% GF		
45a	Disc for neck ring	PTFE		
64	Spacing pipe	Stainless steel	1.4401	AISI 316
69	Spacing pipe	Stainless steel	1.4401	AISI 316
Intermediate chamber with bearing				
4a	Intermediate chamber	Stainless steel	1.4301	AISI 304
4a	Bearing in chamber	Ceramic Al ₂ O ₃ 95-100% Hilox		
		PPS 40% GF		
45	Neck ring	Tin/bronze # (only SPK 8)	2.1020.10.	
45a	Disc for neck ring	PTFE		
47a	Bearing ring	Tungsten # carbide		
64a	Spacing pipe	Stainless steel	1.4401	AISI 316
64b	Spacing pipe	Stainless steel	1.4401	AISI 316
Bottom intermediate chamber				
5a	Intermediate chamber	Stainless steel	1.4301	AISI 304
45	Neck ring	Tin/bronze# (only SPK 8)	2.1020.10.	
45	Neck ring	PPS 40 % GF		
45a	Disc for neck ring	PTFE		
64c	Spacing pipe	Stainless steel	1.4401	AISI 316
Suction interconnector				
84	Filter: SPK 1, 2 and 4, ø2 mm holes# SPK 8, ø4 mm holes	Stainless steel	1.4301	AISI 304
121	Suction interconnector	Stainless steel	1.4301	AISI 304
84b	Set screw	Stainless steel		
Shaft				
51	Spline shaft	Stainless steel	1.4057	AISI 431
61	Neck ring	Stainless steel	1.4301	AISI 304
62	Stop ring	Stainless steel	1.4436	AISI 316
64c	Neck ring	Stainless steel	1.4401	AISI 316
66	Washer	Stainless steel	1.4301	AISI 304
67	Lock nut	Stainless steel	1.4401	AISI 316
69a	Spacing pipe	Stainless steel	1.4301	AISI 304
112	Spacing pipe	Stainless steel	1.4301	AISI 304
122	Priming screw	Stainless steel	1.4401	AISI 316

Pos.	Description	Materials	DIN W.-Nr.	AISI/ASTM
Shaft seal (AUUV)				
102	O-ring	FKM		
103	Neck ring, upper	Wolframkarbid		
104	Neck ring, lower	Wolframkarbid		
107	O-ring	FKM		
108	Spring	Stainless steel, CrNiMo	1.4401	AISI 316
111	Disc	Stainless steel		
Impeller				
49	Impeller	Stainless steel	1.4301	AISI 304
49d	Impeller, lower	Stainless steel	1.4301	AISI 304
Strap				
26	Strap	Stainless steel	1.4301	AISI 304
36	Nut	Stainless steel		
66a	Washer	Stainless steel		
Coupling				
8	Coupling	Cast iron EN-GJS-400-15 Sinter metal	0.7040	ASTM 60-40-18
9	Hexagon socket head screw	Steel		
10	Shaft pin	Stainless steel	1.4301	AISI 304

Sectional drawing SPK 1, SPK 2

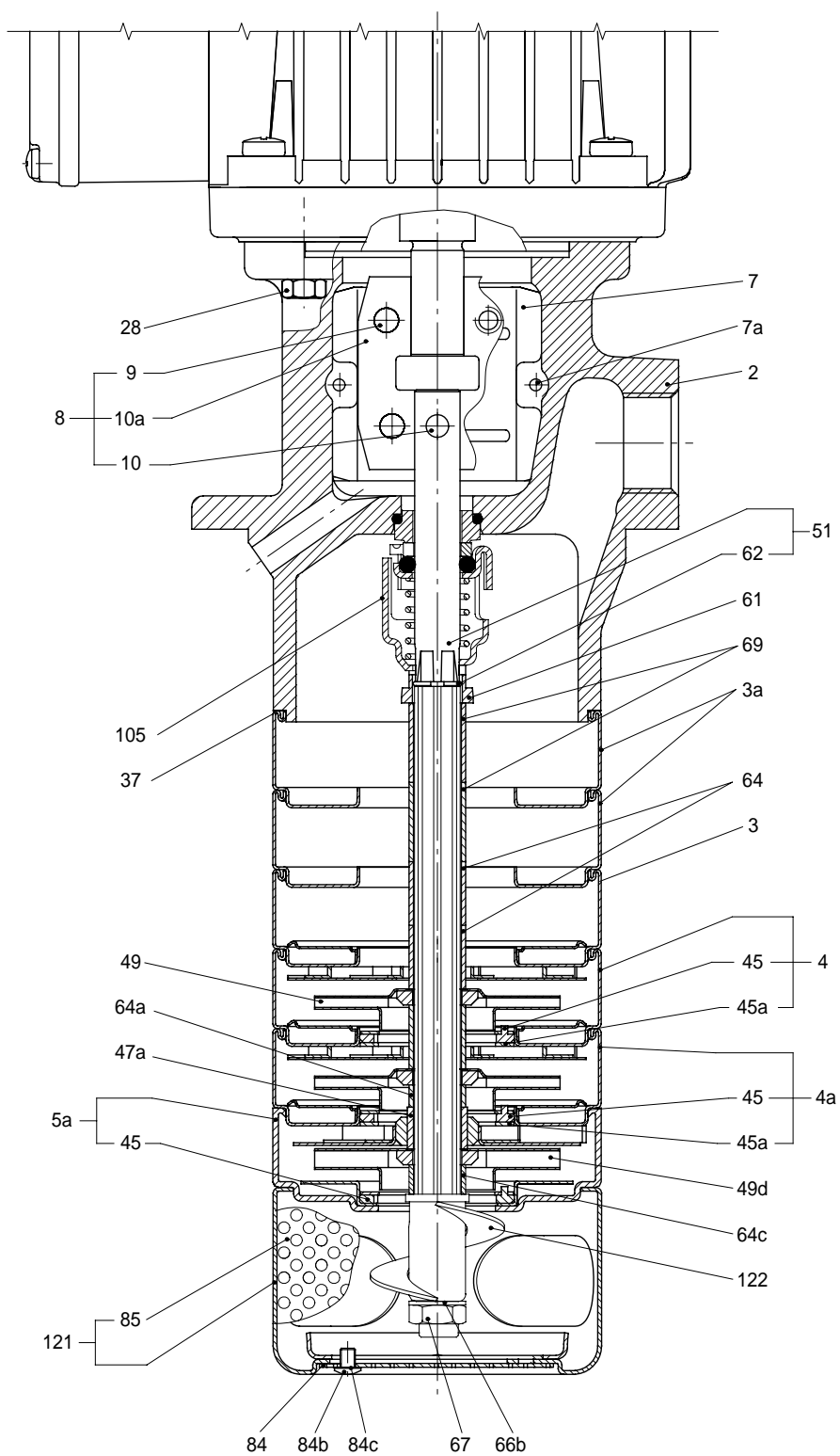

TM019281.1901

Sectional drawing SPK 4

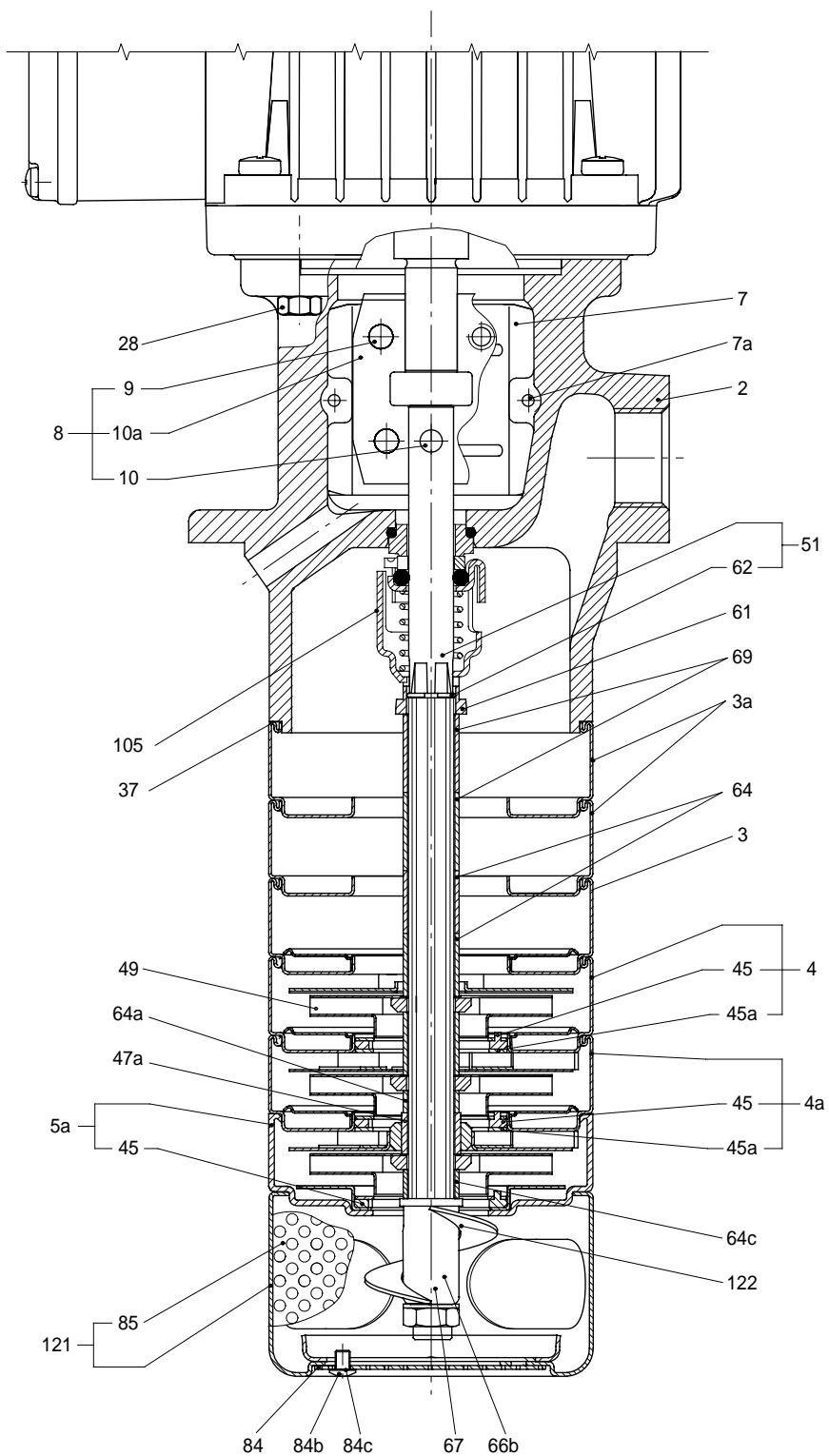

TM02 0111 1901

Sectional drawing SPK 8

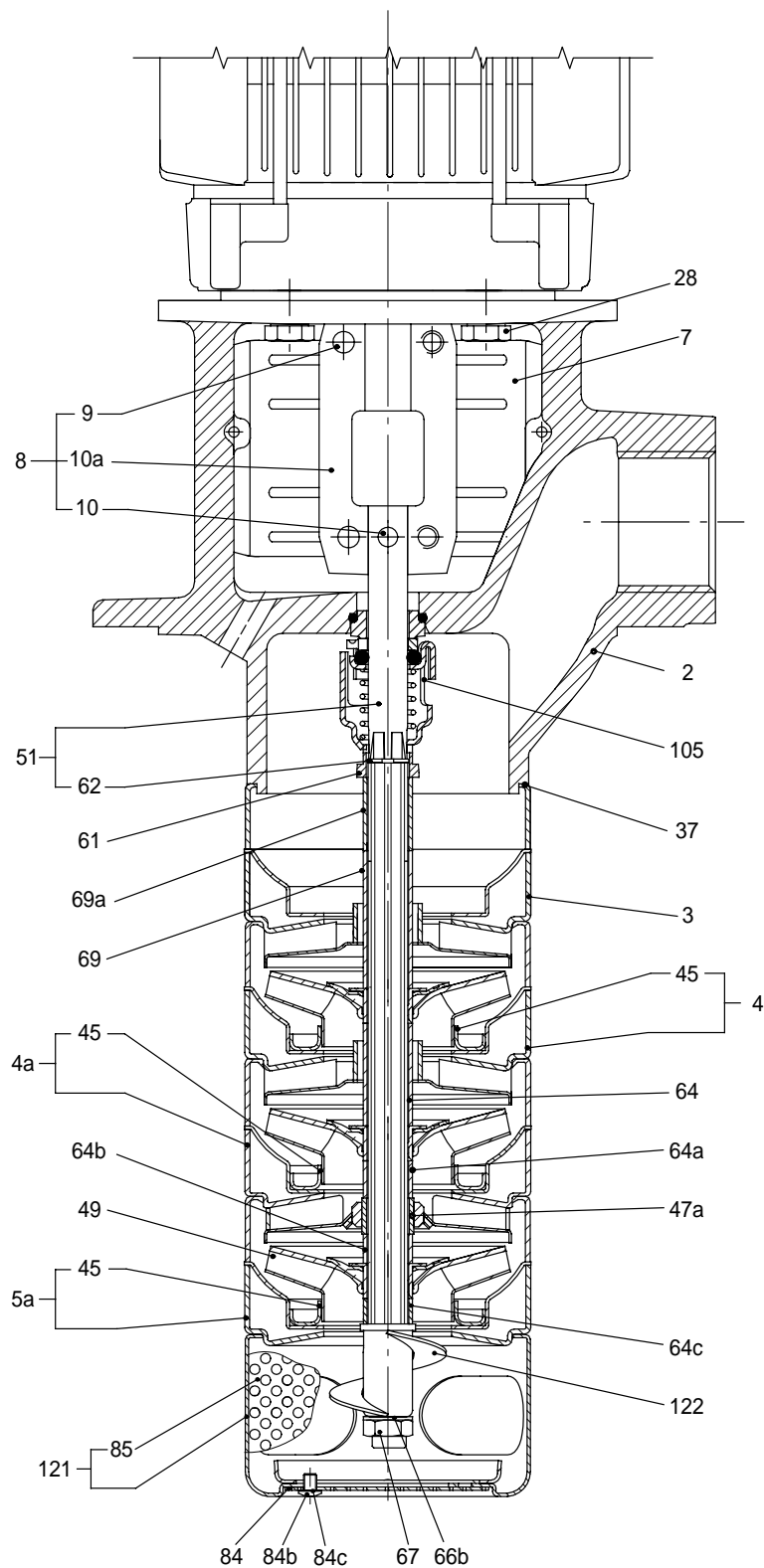

TM02.0112.1901

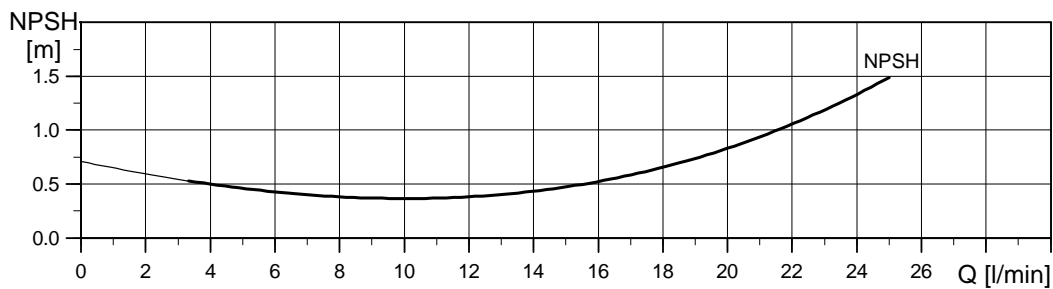
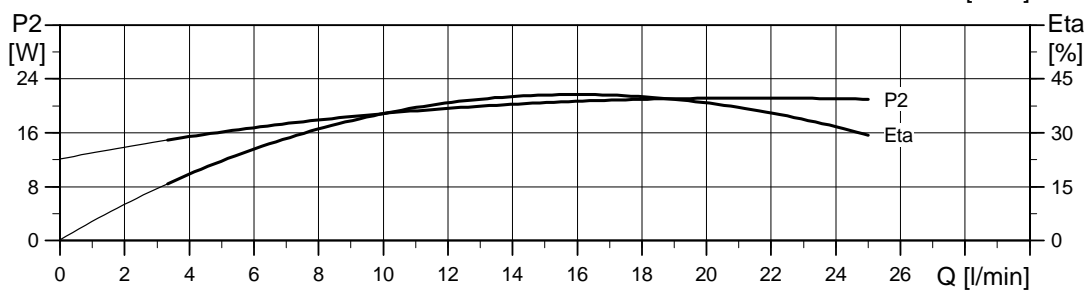
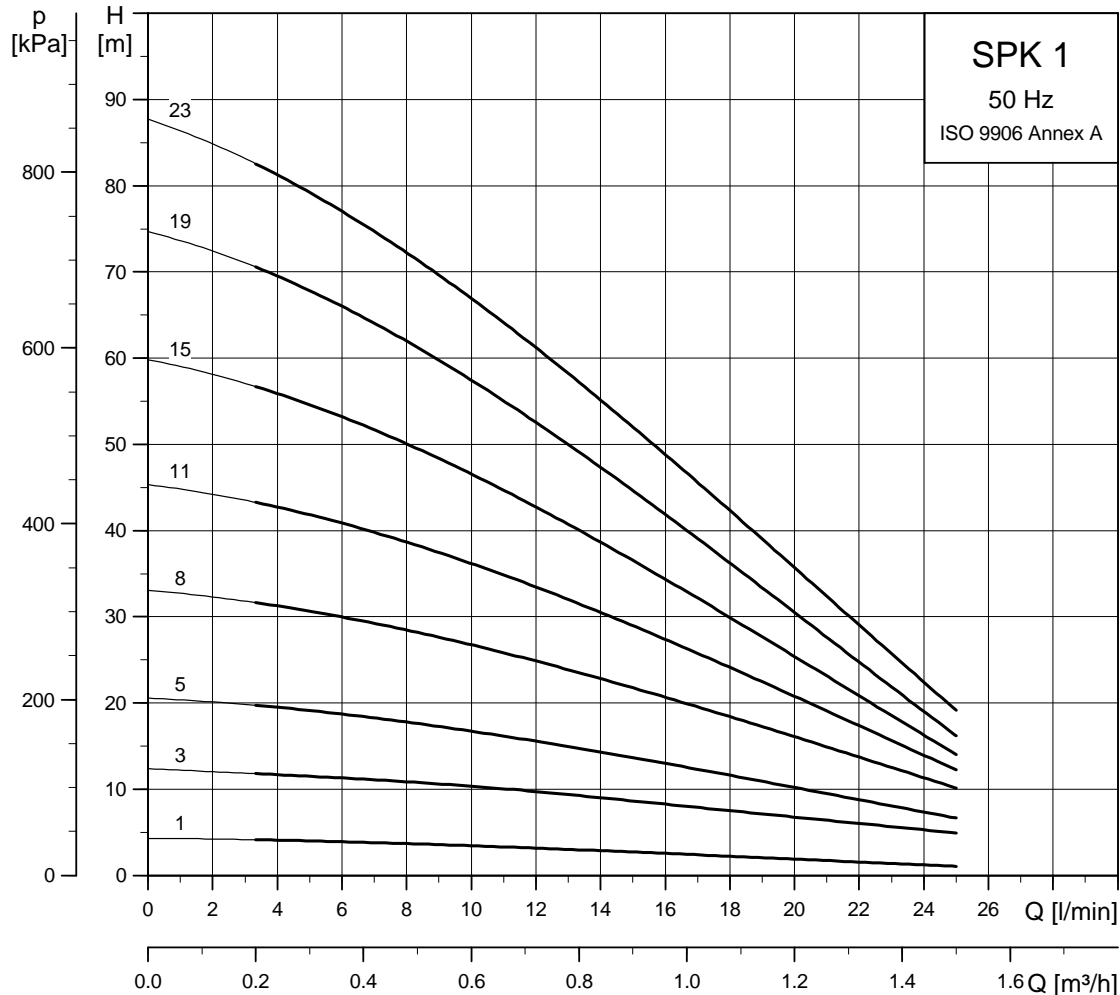

TM001930 3700

Dimensional sketches

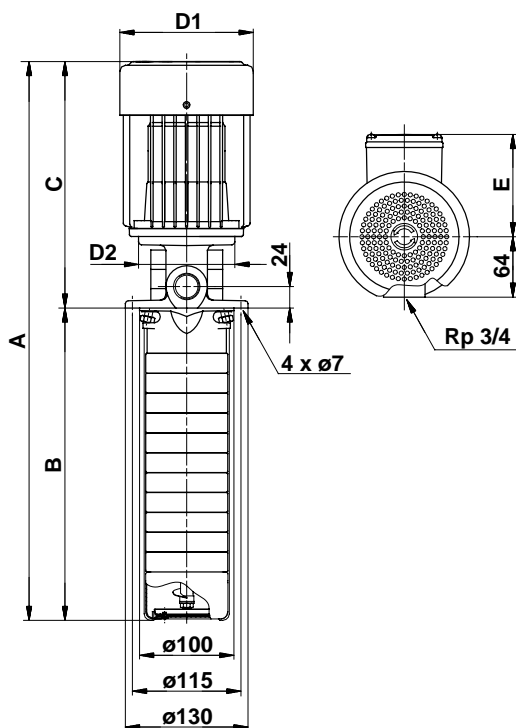

Dimensions and weights

Pump type	Dimensions [mm]						Weight [kg]*
	A	B	C	D1	D2	E	
SPK 1-1/1	398	140	257	118	90	95	4.6
SPK 1-3/3	440	182	257	118	90	95	5.2
SPK 1-5/5	482	224	257	118	90	95	5.7
SPK 1-8/8	545	287	257	118	90	95	6.4
SPK 1-11/11**	595	350	245	142	120	109	8.7
SPK 1-15/15	670	434	266	142	120	109	12.5
SPK 1-19/19	784	518	266	142	120	109	13.1
SPK 1-23/23	868	602	266	142	120	109	14.9

* The stated weights apply to SPK only. For SPKI, add 1 kg.#

** The electrical data apply to 3 x 220-255/380-440 V, 50 Hz.

SPK with extension pipe

Pump type	Dimensions [mm]						Weight [kg]*
	A	B	C	D1	D2	E	
SPK 1-23/23	1271	1005	266	142	120	109	19.5

* The stated weights apply to SPK only. For SPKI, add 1 kg.

Electrical data

3 x 220-240/380-415 V, 50 Hz

Pump type	Motor		Full load current $I_{1/1}$ [A]	Power factor $\cos \pi_{1/1}$	Motor efficiency ξ [%]	$\frac{I_{start}}{I_{1/1}}$
	Type	P_2 [kW]				
SPK 1-1/1	MG 63	0.06	0.31/0.18	0.79-0.72	70	4.4-4.8
SPK 1-3/3	MG 63	0.06	0.31/0.18	0.79-0.72	70	4.4-4.8
SPK 1-5/5	MG 63	0.12	0.59/0.34	0.80-0.72	71	4.2-4.6
SPK 1-8/8	MG 63	0.18	0.90/0.52	0.79-0.71	72	4.1-4.5
SPK 1-11/11**	MG 71A	0.25	1.12/0.65	0.83-0.71	73	5.7-6.2
SPK 1-15/15	MG 71A	0.37	1.66/0.96	0.84-0.76	72	4.8-5.2
SPK 1-19/19	MG 71A	0.37	1.66/0.96	0.84-0.76	72	4.8-5.2
SPK 1-23/23	MG 71B	0.55	2.50/1.44	0.84-0.76	72	4.8-5.2

** The electrical data apply to 3 x 220-255/380-440 V, 50 Hz.

SPK with extension pipe

Pump type	Motor		Full load current $I_{1/1}$ [A]	Power factor $\cos \pi_{1/1}$	Motor efficiency ξ [%]	$\frac{I_{start}}{I_{1/1}}$
	Type	P_2 [kW]				
SPK 1-23/23	MG 71B	0.55	2.50/1.44	0.84-0.76	72	4.8-5.2

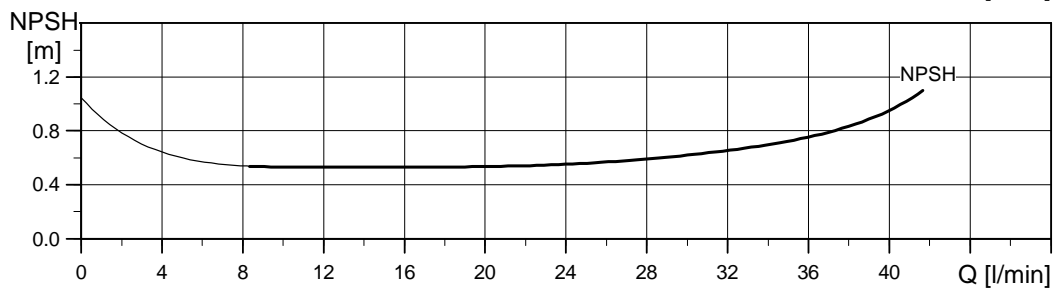
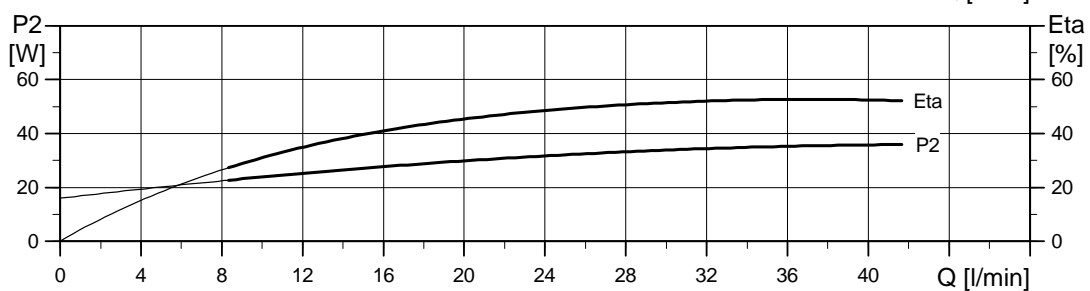
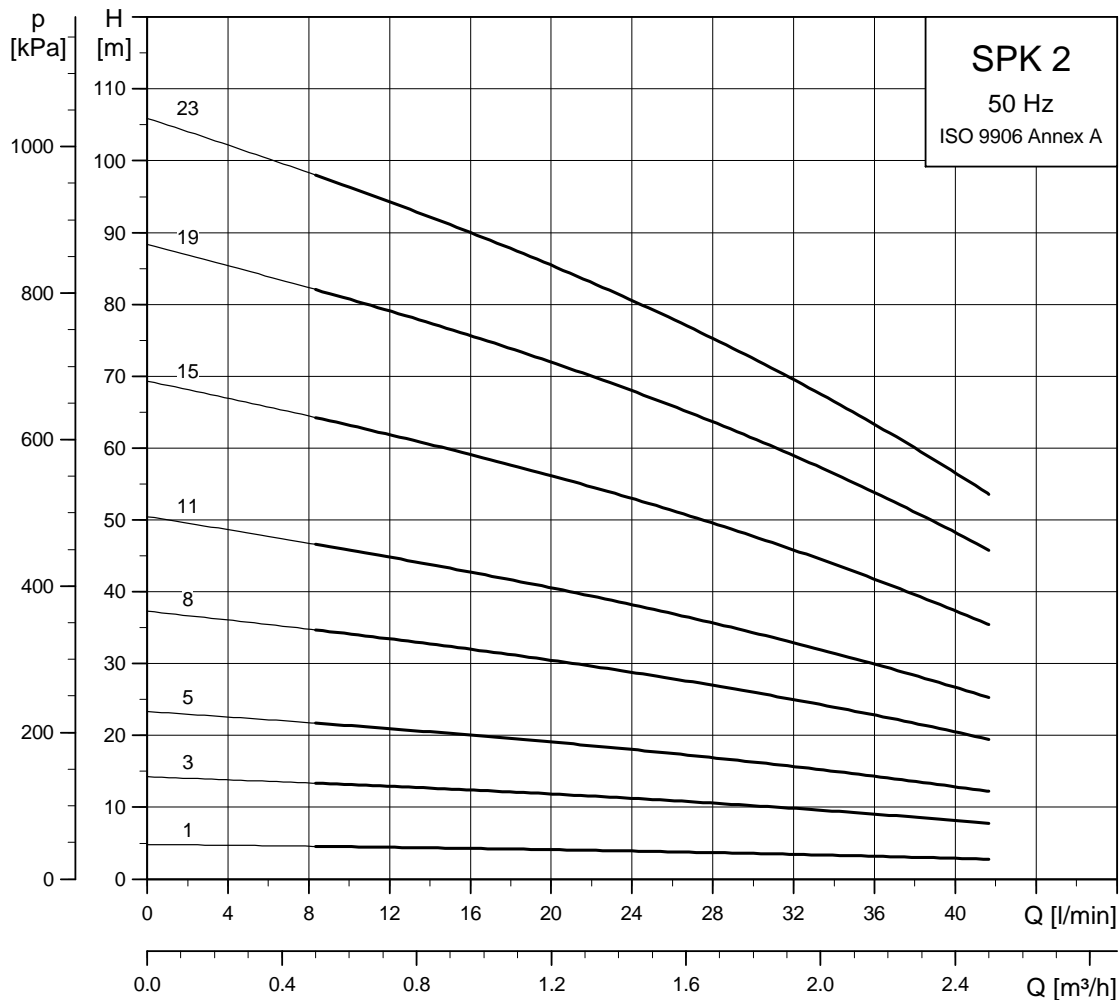

TM0019323700

Dimensional sketches

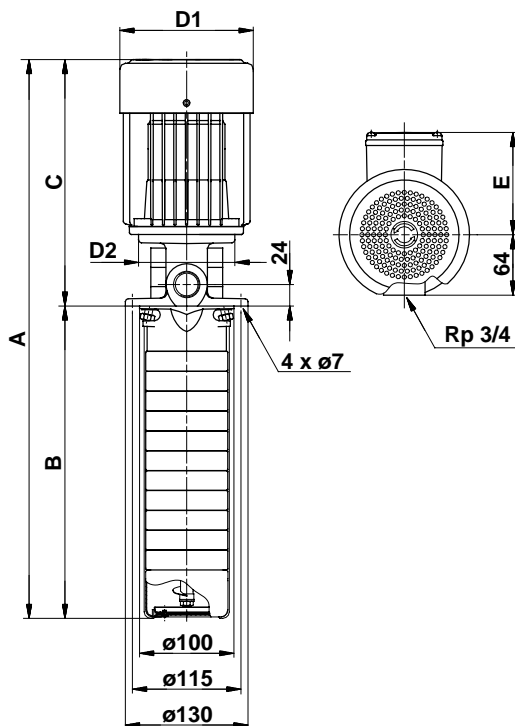

TM00 1917 3297

Dimensions and weights

Pump type	Dimensions [mm]						Weight [kg]*
	A	B	C	D1	D2	E	
SPK 2-1/1	398	140	257	118	90	95	4.6
SPK 2-3/3	440	182	257	118	90	95	5.2
SPK 2-5/5	482	224	257	118	90	95	5.8
SPK 2-8/8	553	287	266	142	120	109	11.0
SPK 2-11/11	616	350	266	142	120	109	11.7
SPK 2-15/15	700	434	266	142	120	109	13.0
SPK 2-19/19	824	518	306	142	120	109	15.4
SPK 2-23/23	908	602	306	142	120	109	16.2

* The stated weights apply to SPK only. For SPKI, add 1 kg.

SPK with extension pipe

Pump type	Dimensions [mm]						Weight [kg]*
	A	B	C	D1	D2	E	
SPK 2-23/23	1311	1005	306	142	120	109	20.8

* The stated weights apply to SPK only. For SPKI, add 1 kg.

Electrical data

3 x 220-240/380-415 V, 50 Hz

Pump type	Motor		Full load current $I_{1/1}$ [A]	Power factor $\cos \pi_{1/1}$	Motor efficiency ξ [%]	$\frac{I_{start}}{I_{1/1}}$
	Type	P_2 [kW]				
SPK 2-1/1	MG 63	0.06	0.31/0.18	0.79-0.72	70	4.4-4.8
SPK 2-3/3	MG 63	0.12	0.59/0.34	0.80-0.72	71	4.2-4.6
SPK 2-5/5	MG 63	0.18	0.90/0.52	0.79-0.71	72	4.1-4.5
SPK 2-8/8	MG 71A	0.37	1.66/0.96	0.84-0.76	72	4.8-5.2
SPK 2-11/11	MG 71A	0.37	1.66/0.96	0.84-0.76	72	4.8-5.2
SPK 2-15/15	MG 71B	0.55	2.50/1.44	0.84-0.76	72	4.8-5.2
SPK 2-19/19	MG 80A	0.75	3.20/1.86	0.86-0.78	74	5.0-5.5
SPK 2-23/23	MG 80A	0.75	3.20/1.86	0.86-0.78	74	5.0-5.5

SPK with extension pipe

Pump type	Motor		Full load current $I_{1/1}$ [A]	Power factor $\cos \pi_{1/1}$	Motor efficiency ξ [%]	$\frac{I_{start}}{I_{1/1}}$
	Type	P_2 [kW]				
SPK 2-23/23	MG 80A	0.75	3.20/1.86	0.86-0.78	74	5.0-5.5

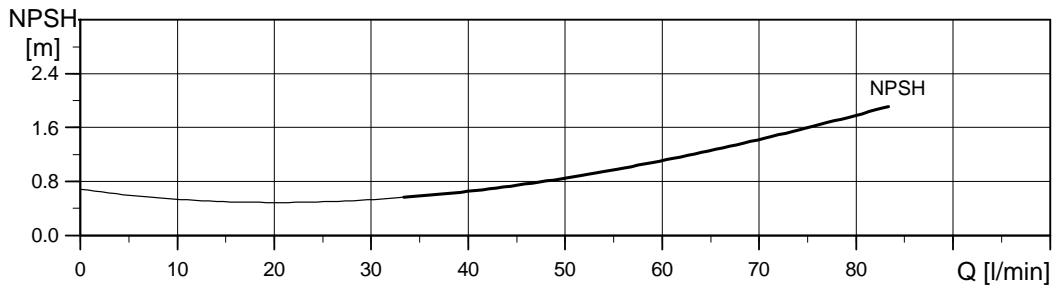
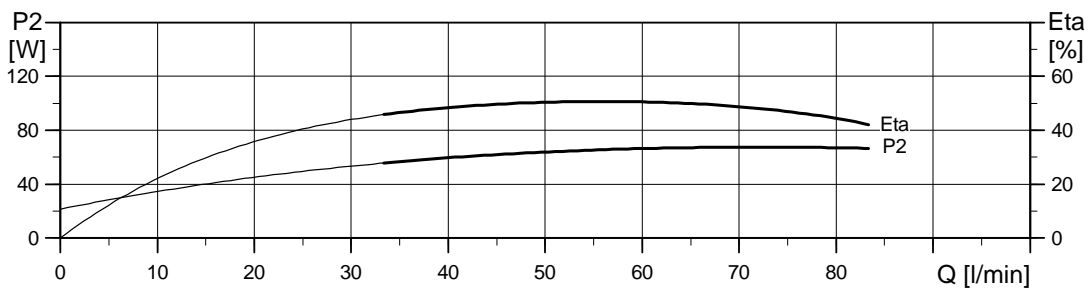
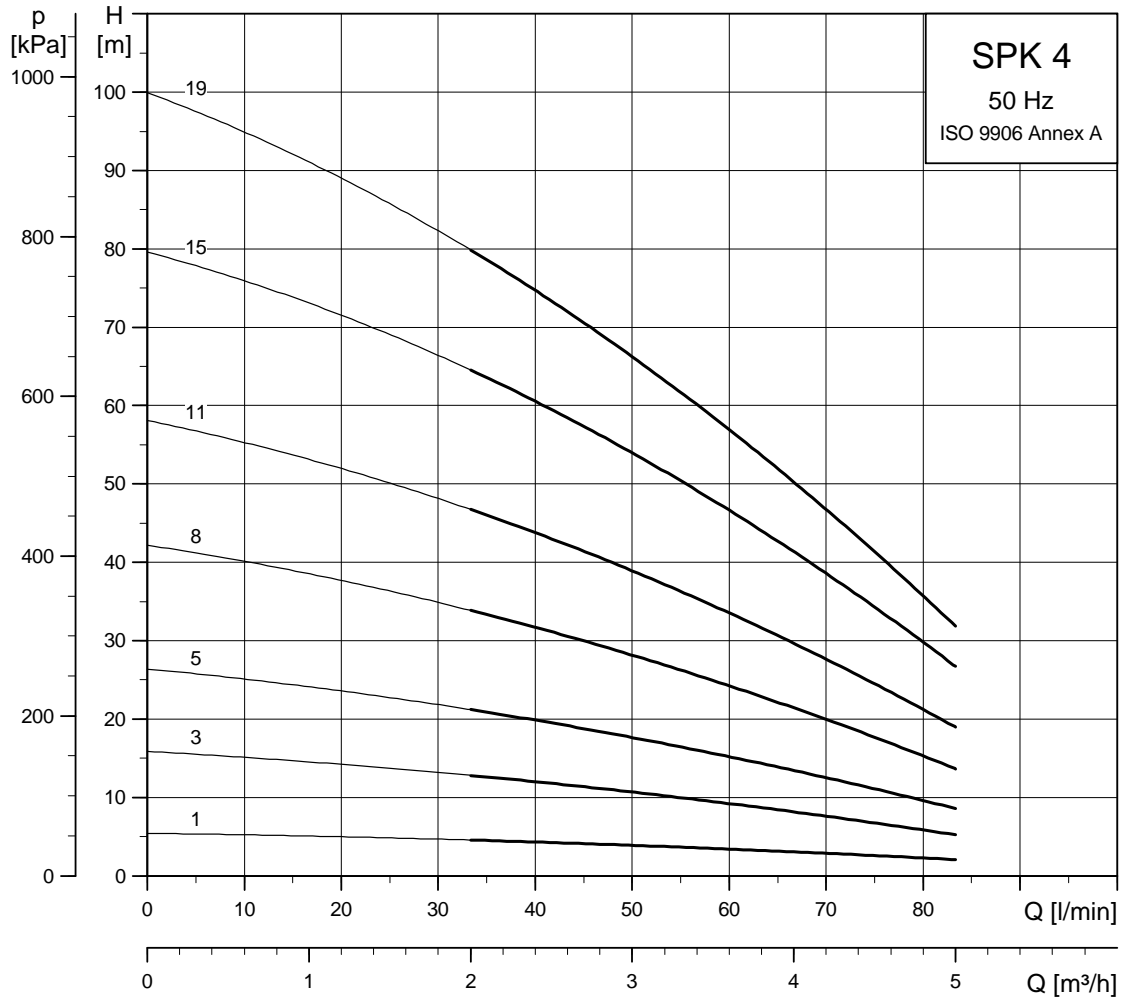

TM001934 3700

Dimensional sketches

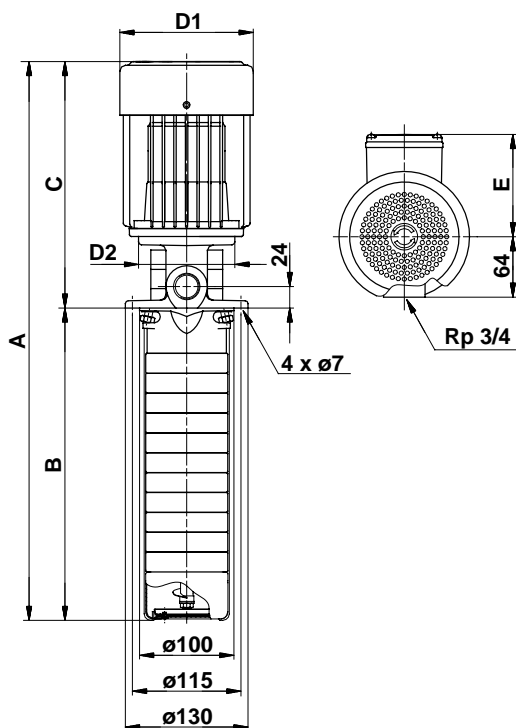

Dimensions and weights

Pump type	Dimensions [mm]						Weight [kg]*
	A	B	C	D1	D2	E	
SPK 4-1/1	398	140	258	118	90	95	4.6
SPK 4-3/3	440	182	258	118	90	95	5.2
SPK 4-5/5	490	224	266	142	120	109	10.3
SPK 4-8/8	553	287	266	142	120	109	11.5
SPK 4-11/11	656	350	306	142	120	109	13.5
SPK 4-15/15	740	434	306	142	120	109	15.9
SPK 4-19/19	824	518	306	142	120	109	16.4

* The stated weights apply to SPK only. For SPKI, add 1.3 kg.

SPK with extension pipe

Pump type	Dimensions [mm]						Weight [kg]*
	A	B	C	D1	D2	E	
SPK 4-19/19	1311	1005	306	142	120	109	21.8

* The stated weights apply to SPK only. For SPKI, add 1.3 kg.

Electrical data

3 x 220-240/380-415 V, 50 Hz

Pump type	Motor		Full load current $I_{1/1}$ [A]	Power factor $\cos \pi_{1/1}$	Motor efficiency ξ [%]	$\frac{I_{start}}{I_{1/1}}$
	Type	P_2 [kW]				
SPK 4-1/1	MG 63	0.06	0.31/0.18	0.79-0.72	70	4.4-4.8
SPK 4-3/3	MG 63	0.18	0.90/0.52	0.79-0.71	72	4.1-4.5
SPK 4-5/5	MG 71A	0.37	1.66/0.96	0.84-0.76	72	4.8-5.2
SPK 4-8/8	MG 71B	0.55	2.50/1.44	0.84-0.76	72	4.8-5.2
SPK 4-11/11	MG 80A	0.75	3.20/1.86	0.86-0.78	74	5.0-5.5
SPK 4-15/15	MG 80B	1.10	4.60/2.65	0.87-0.79	76	5.2-5.7
SPK 4-19/19	MG 80B	1.10	4.60/2.65	0.87-0.79	76	5.2-5.7

SPK with extension pipe

Pump type	Motor		Full load current $I_{1/1}$ [A]	Power factor $\cos \pi_{1/1}$	Motor efficiency ξ [%]	$\frac{I_{start}}{I_{1/1}}$
	Type	P_2 [kW]				
SPK 4-19/19	MG 80B	1.10	4.60/2.65	0.87-0.79	76	5.2-5.7

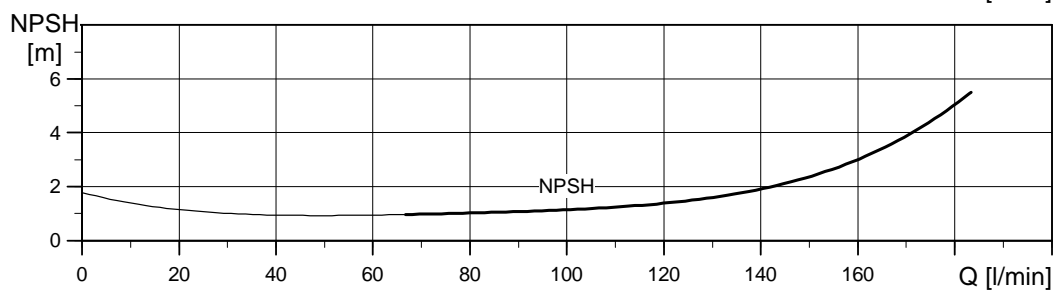
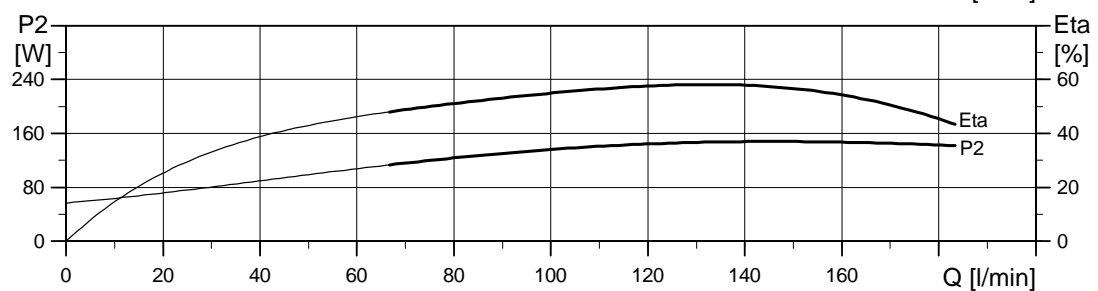
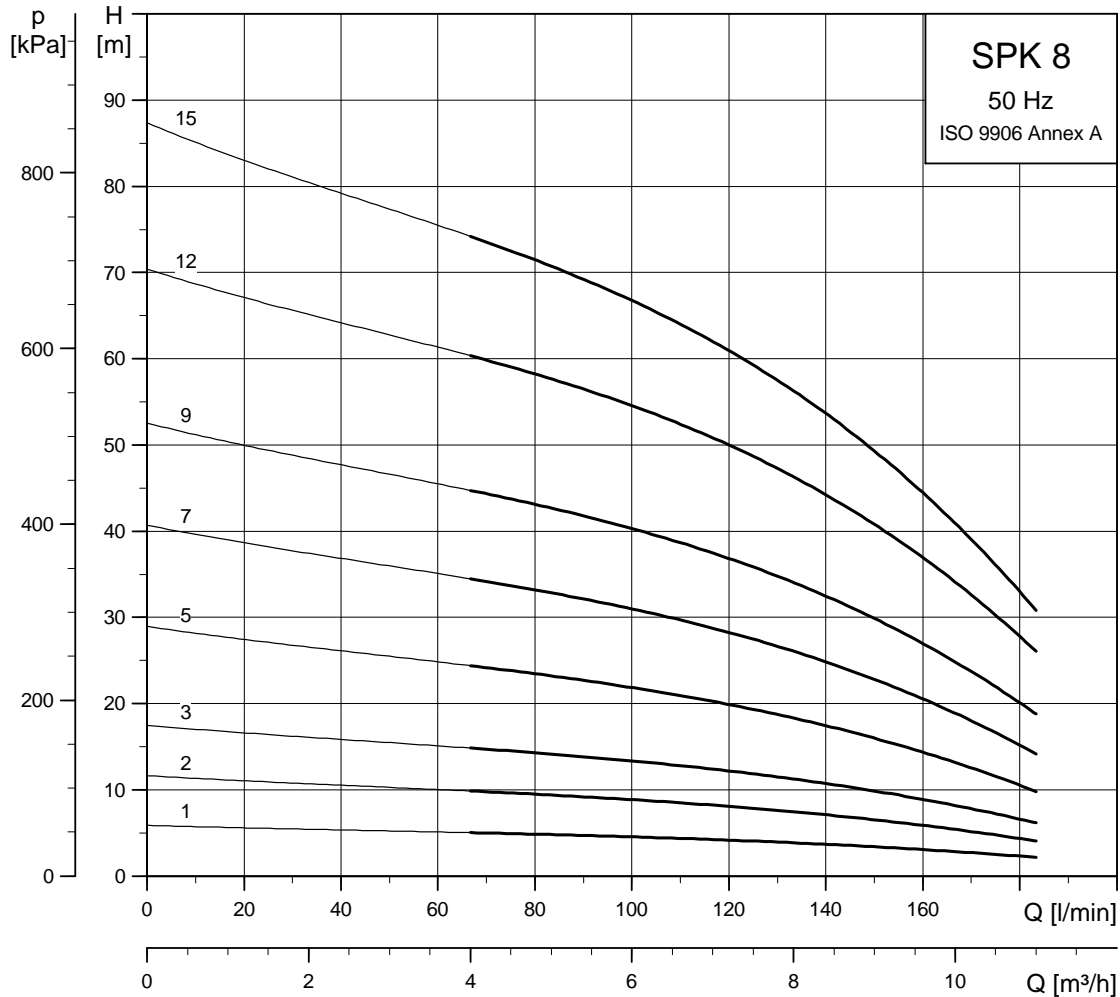

TM0019363700

Dimensional sketches

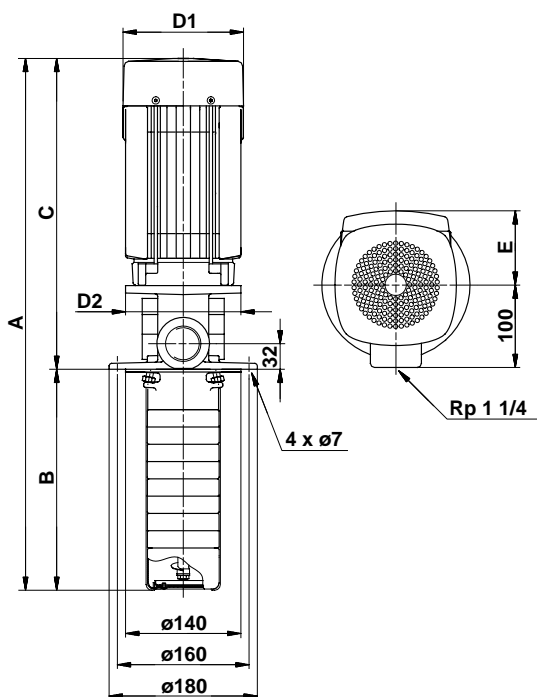

Dimensions and weights

Pump type	Dimensions [mm]						Weight [kg]*
	A	B	C	D1	D2	E	
SPK 8-1/1**	454	182	273	142	140	109	9.4
SPK 8-2/2	517	224	293	142	140	109	12.6
SPK 8-3/3	559	266	293	142	140	109	13.6
SPK 8-5/5	683	350	333	142	140	109	15.9
SPK 8-7/7	767	434	333	142	140	109	18.3
SPK 8-9/9	902	518	384	178	140	110	25.6
SPK 8-12/12	1028	644	384	178	140	110	29.1
SPK 8-15/15	1154	770	384	178	140	110	30.6

* The stated weights apply to SPK only. For SPKI, add 1.3 kg.#

** The electrical data apply to 3 x 220-255/380-440 V, 50 Hz.

SPK with extension pipe

Pump type	Dimensions [mm]						Weight [kg]*
	A	B	C	D1	D2	E	
SPK 8-15/15	1389	1005	384	178	140	110	33.6

* The stated weights apply to SPK only. For SPKI, add 1.3 kg.

Electrical data

3 x 220-240/380-415 V, 50 Hz

Pump type	Motor		Full load current $I_{1/1}$ [A]	Power factor $\cos \pi_{1/1}$	Motor efficiency ξ [%]	$\frac{I_{start}}{I_{1/1}}$
	Type	P_2 [kW]				
SPK 8-1/1**	MG 71A	0.25	1.12/0.65	0.83-0.71	73	5.7-6.2
SPK 8-2/2	MG 71A	0.37	1.66/0.96	0.84-0.76	72	4.8-5.2
SPK 8-3/3	MG 71B	0.55	2.50/1.44	0.84-0.76	72	4.8-5.2
SPK 8-5/5	MG 80A	0.75	3.20/1.86	0.86-0.78	74	5.0-5.5
SPK 8-7/7	MG 80B	1.10	4.60/2.65	0.87-0.79	76	5.2-5.7
SPK 8-9/9	MG 90SA	1.50	5.90/3.40	0.85-0.79	82	6.3-6.9
SPK 8-12/12	MG 90LA	2.20	8.25/4.75	0.87-0.82	84	7.0-7.6
SPK 8-15/15	MG 90LA	2.20	8.25/4.75	0.87-0.82	84	7.0-7.6

** The electrical data apply to 3 x 220-255/380-440 V, 50 Hz.

SPK with extension pipe

Pump type	Motor		Full load current $I_{1/1}$ [A]	Power factor $\cos \pi_{1/1}$	Motor efficiency ξ [%]	$\frac{I_{start}}{I_{1/1}}$
	Type	P_2 [kW]				
SPK 8-15/15	MG 90LA	2.20	8.25/4.75	0.87-0.82	84	7.0-7.6

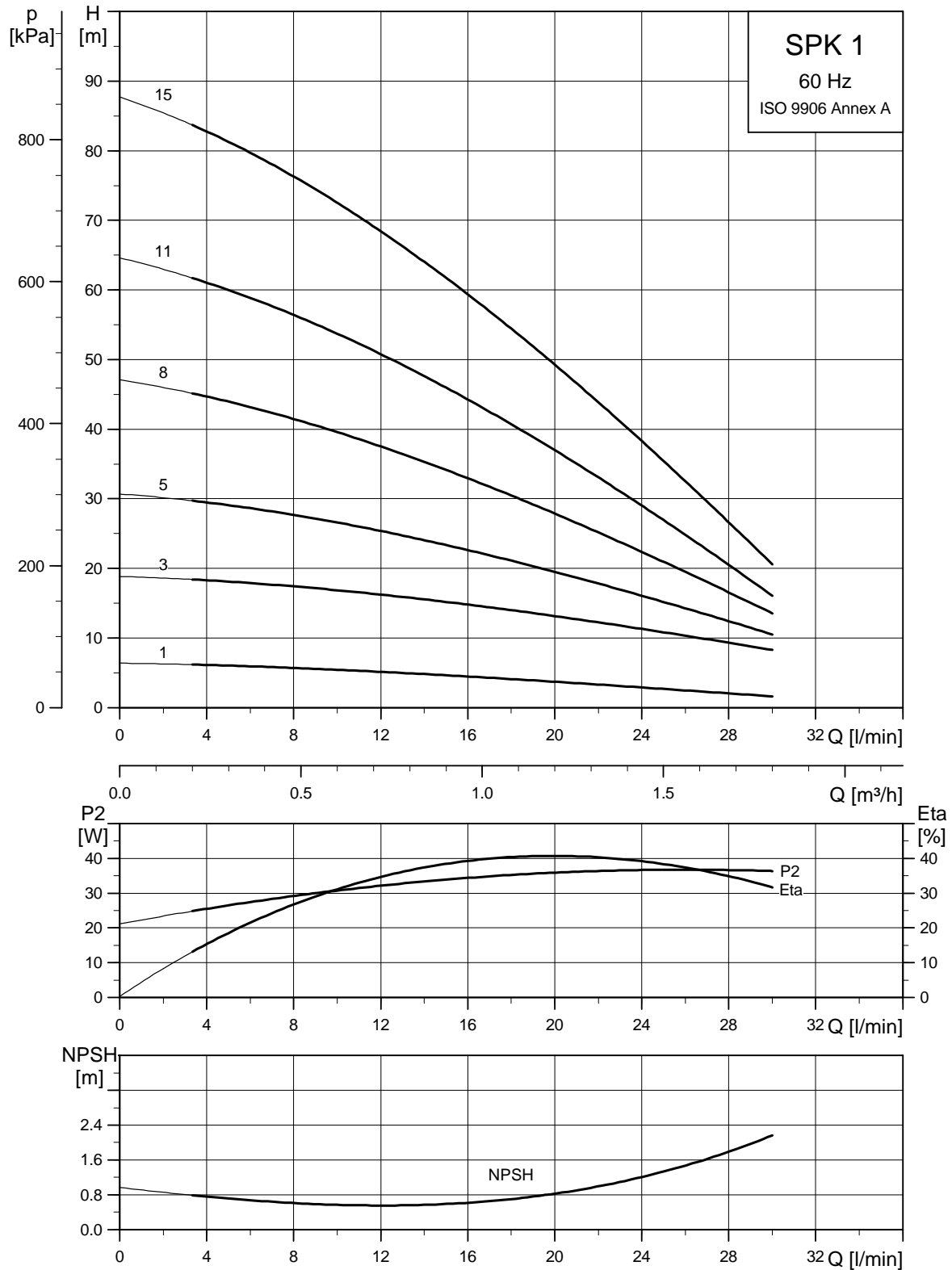

TM0019313700

Dimensional sketches

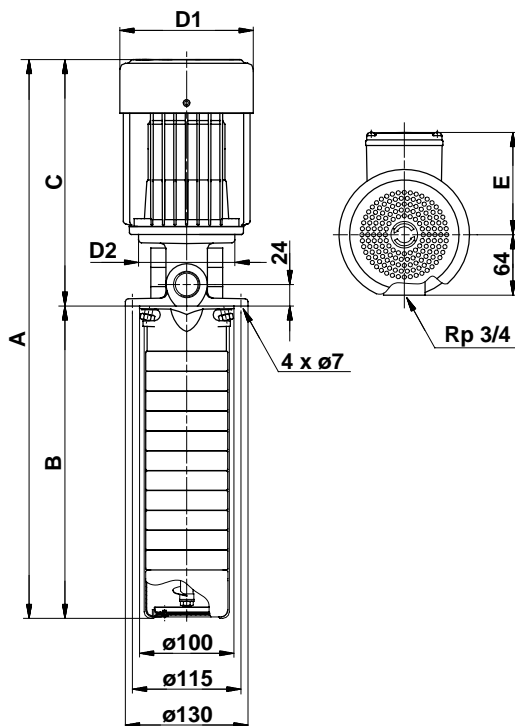

Dimensions and weights

Pump type	Dimensions [mm]						Weight [kg]*
	A	B	C	D1	D2	E	
SPK 1-1/1	398	140	257	118	90	95	4.6
SPK 1-3/3	440	182	257	118	90	95	5.2
SPK 1-5/5	482	224	257	118	90	95	5.7
SPK 1-8/8	532	287	245	142	120	109	8.1
SPK 1-11/11	616	350	266	142	120	109	11.5
SPK 1-15/15	700	434	266	142	120	109	13.0
SPK 1-19/15	784	518	266	142	120	109	13.3
SPK 1-23/15	868	602	266	142	120	109	13.6

* The stated weights apply to SPK only. For SPK1, add 1 kg.

SPK with extension pipe

Pump type	Dimensions [mm]						Weight [kg]*
	A	B	C	D1	D2	E	
SPK 1-23/15	1271	1005	266	142	120	109	18.2

* The stated weights apply to SPK only. For SPK1, add 1 kg.

Electrical data

3 x 220-255/380-440 V, 60 Hz

Pump type	Motor		Full load current $I_{1/1}$ [A]	Power factor $\cos \pi_{1/1}$	Motor efficiency ξ [%]	$\frac{I_{start}}{I_{1/1}}$
	Type	P_2 [kW]				
SPK 1-1/1	MG 63	0.06	0.29/0.17	0.83-0.67	69	4.4-5.5
SPK 1-3/3	MG 63	0.12	0.55/0.32	0.85-0.67	71	4.2-5.2
SPK 1-5/5	MG 63	0.18	0.80/0.46	0.84-0.64	72	4.0-6.0
SPK 1-8/8	MG 71A	0.25	1.10-1.02/0.63-0.59	0.86-0.77	73	5.5-7.0
SPK 1-11/11	MG 71A	0.37	1.58-1.46/0.91-0.84	0.88-0.82	72-73	4.8-6.0
SPK 1-15/15	MG 71B	0.55	2.40-2.18/1.38-1.26	0.88-0.82	71-72	4.8-6.0
SPK 1-19/15	MG 71B	0.55	2.40-2.18/1.38-1.26	0.88-0.82	71-72	4.8-6.0
SPK 1-23/15	MG 71B	0.55	2.40-2.18/1.38-1.26	0.88-0.82	71-72	4.8-6.0

SPK with extension pipe

Pump type	Motor		Full load current $I_{1/1}$ [A]	Power factor $\cos \pi_{1/1}$	Motor efficiency ξ [%]	$\frac{I_{start}}{I_{1/1}}$
	Type	P_2 [kW]				
SPK 1-23/15	MG 71B	0.55	2.40-2.18/1.38-1.26	0.88-0.82	71-72	4.8-6.0

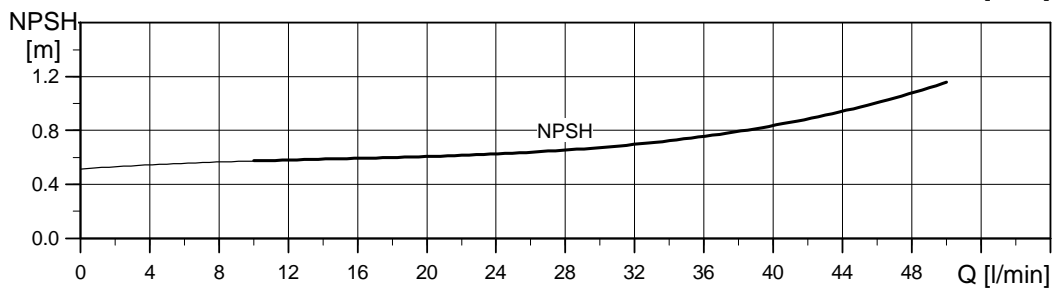
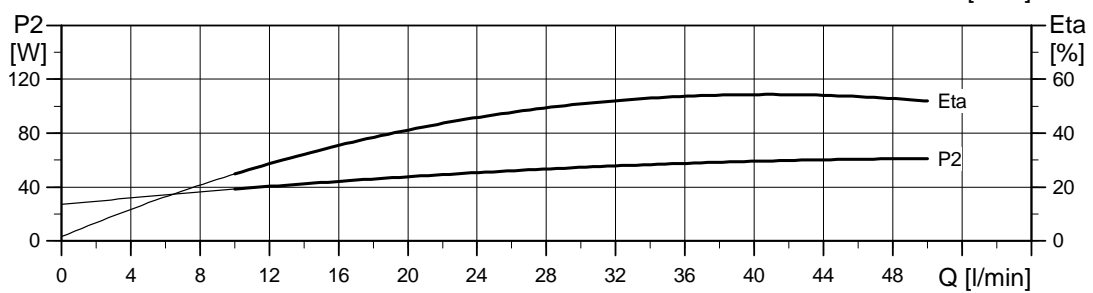
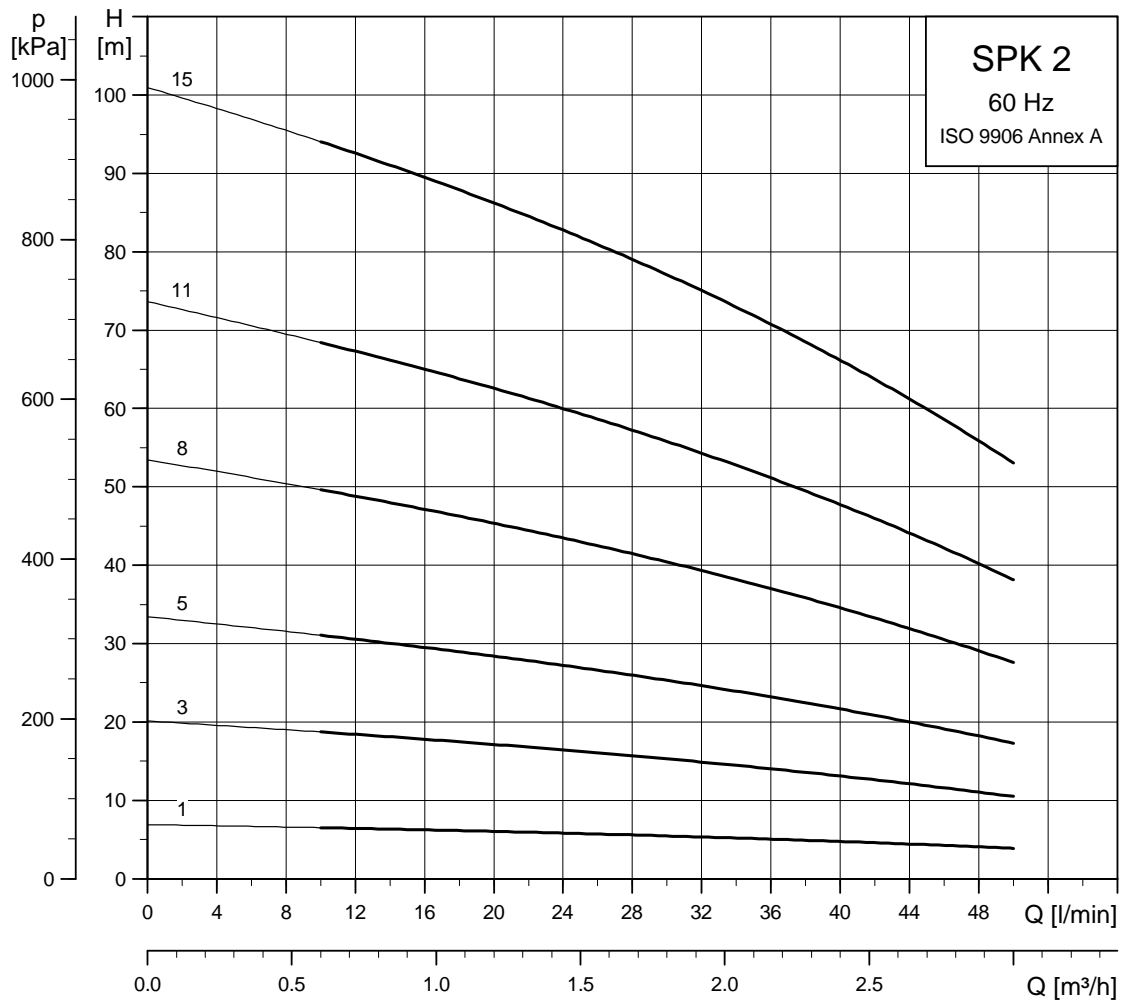

TM001933 3700

Dimensional sketches

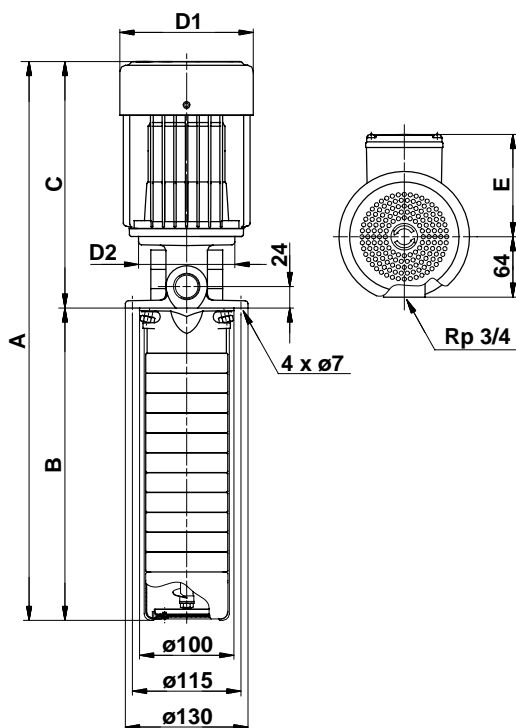

Dimensions and weights

Pump type	Dimensions [mm]						Weight [kg]*
	A	B	C	D1	D2	E	
SPK 2-1/1	398	140	257	118	90	95	4.6
SPK 2-3/3	440	182	257	118	90	95	5.2
SPK 2-5/5	490	224	266	142	120	109	10.3
SPK 2-8/8	553	287	266	142	120	109	11.5
SPK 2-11/11	656	350	306	142	120	109	13.8
SPK 2-15/15	740	434	306	142	120	109	16.0
SPK 2-19/15	824	518	306	142	120	109	16.3
SPK 2-23/15	908	602	306	142	120	109	16.6

* The stated weights apply to SPK only. For SPKI, add 1 kg.

SPK with extension pipe

Pump type	Dimensions [mm]						Weight [kg]*
	A	B	C	D1	D2	E	
SPK 2-23/15	1311	1005	306	142	120	109	21.2

* The stated weights apply to SPK only. For SPKI, add 1 kg.

Electrical data

3 x 220-255/380-440 V, 60 Hz

Pump type	Motor		Full load current $I_{1/1}$ [A]	Power factor $\cos \pi_{1/1}$	Motor efficiency ξ [%]	$\frac{I_{start}}{I_{1/1}}$
	Type	P_2 [kW]				
SPK 2-1/1	MG 63	0.06	0.29/0.17	0.83-0.67	69	4.4-5.5
SPK 2-3/3	MG 63	0.18	0.80/0.46	0.84-0.64	72	4.0-6.0
SPK 2-5/5	MG 71A	0.37	1.58-1.46/0.91-0.84	0.88-0.82	72-73	4.8-6.0
SPK 2-8/8	MG 71B	0.55	2.40-2.18/1.38-1.26	0.88-0.82	71-72	4.8-6.0
SPK 2-11/11	MG 80A	0.75	3.15-2.85/1.82-1.64	0.89-0.84	73-74	5.1-6.5
SPK 2-15/15	MG 80B	1.10	4.50-4.00/2.60-2.32	0.89-0.84	76-77	5.1-6.5
SPK 2-19/15	MG 80B	1.10	4.50-4.00/2.60-2.32	0.89-0.84	76-77	5.1-6.5
SPK 2-23/15	MG 80B	1.10	4.50-4.00/2.60-2.32	0.89-0.84	76-77	5.1-6.5

SPK with extension pipe

Pump type	Motor		Full load current $I_{1/1}$ [A]	Power factor $\cos \pi_{1/1}$	Motor efficiency ξ [%]	$\frac{I_{start}}{I_{1/1}}$
	Type	P_2 [kW]				
SPK 2-23/15	MG 80B	1.10	4.50-4.00/2.60-2.32	0.89-0.84	76-77	5.1-6.5

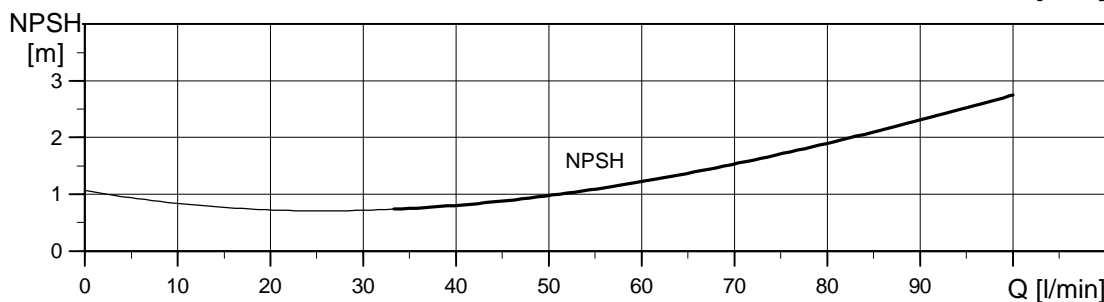
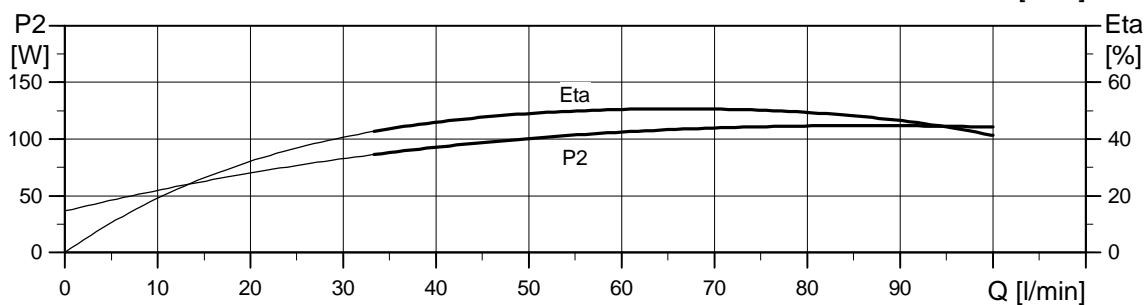
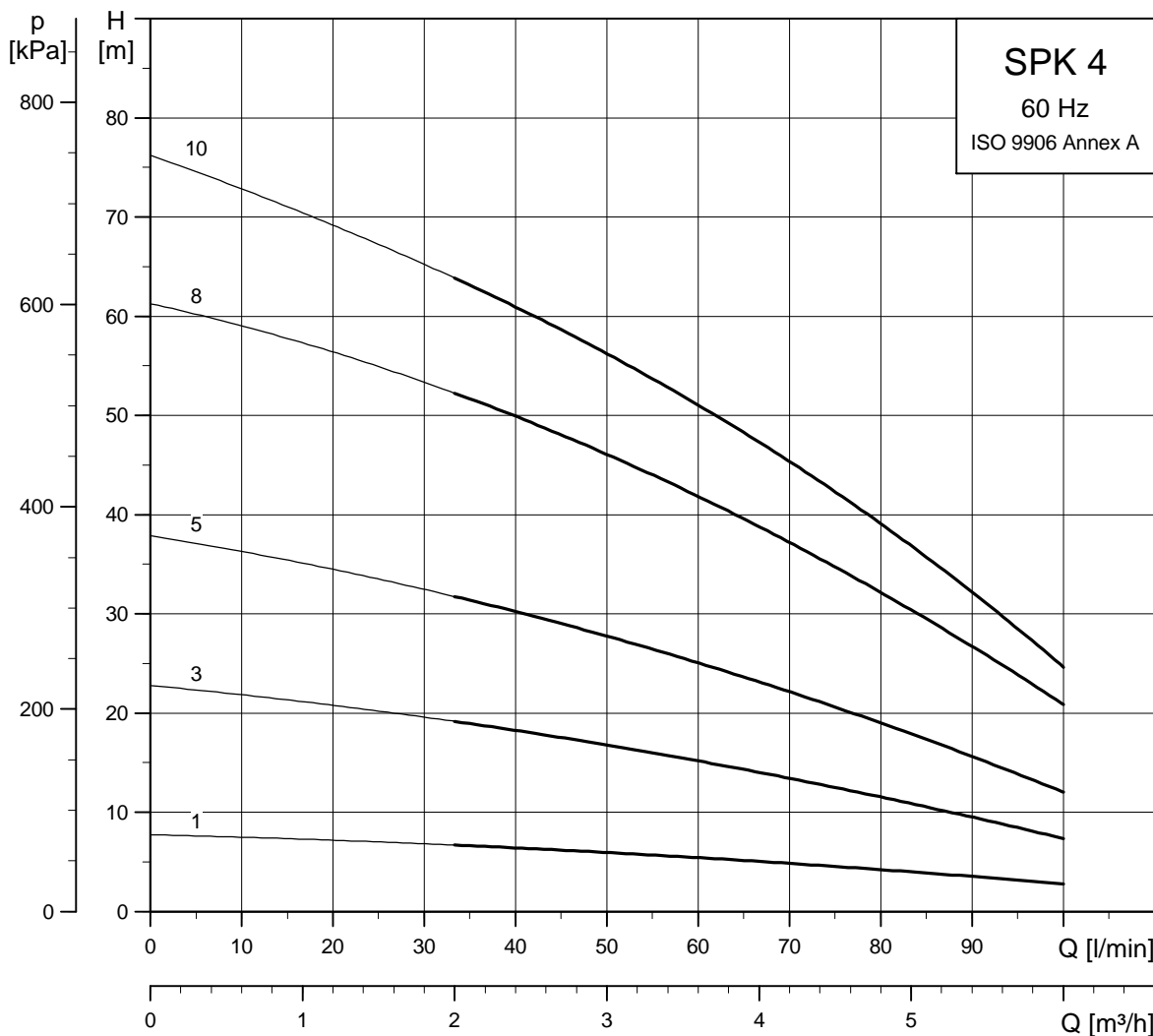

TM001935 3700

Dimensional sketches

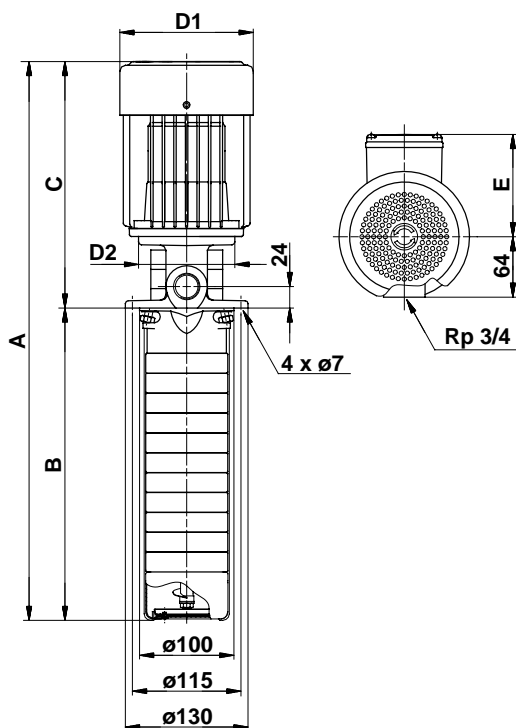

Dimensions and weights

Pump type	Dimensions [mm]						Weight [kg]*
	A	B	C	D1	D2	E	
SPK 4-1/1	398	140	258	118	90	95	4.6
SPK 4-3/3	448	182	266	142	120	109	9.7
SPK 4-5/5	490	224	266	142	120	109	10.8
SPK 4-8/8	593	287	306	142	120	109	14.2
SPK 4-11/10	656	350	306	142	120	109	15.4
SPK 4-15/10	740	434	306	142	120	109	15.7
SPK 4-19/10	824	518	306	142	120	109	16.0

* The stated weights apply to SPK only. For SPK1, add 1.3 kg.

SPK with extension pipe

Pump type	Dimensions [mm]						Weight [kg]*
	A	B	C	D1	D2	E	
SPK 4-19/10	1311	1005	306	142	120	109	21.4

* The stated weights apply to SPK only. For SPK1, add 1.3 kg.

Electrical data

3 x 220-255/380-440 V, 60 Hz

Pump type	Motor		Full load current $I_{1/1}$ [A]	Power factor $\cos \pi_{1/1}$	Motor efficiency ξ [%]	$\frac{I_{start}}{I_{1/1}}$
	Type	P_2 [kW]				
SPK 4-1/1	MG 63	0.12	0.55/0.32	0.85-0.67	71	4.2-5.2
SPK 4-3/3	MG 71A	0.37	1.58-1.46/0.91-0.84	0.88-0.82	72-73	4.8-6.0
SPK 4-5/5	MG 71B	0.55	2.40-2.18/1.38-1.26	0.88-0.82	71-72	4.8-6.0
SPK 4-8/8	MG 80B	1.10	4.50-4.00/2.60-2.32	0.89-0.84	76-77	5.1-6.5
SPK 4-11/10	MG 80B	1.10	4.50-4.00/2.60-2.32	0.89-0.84	76-77	5.1-6.5
SPK 4-15/10	MG 80B	1.10	4.50-4.00/2.60-2.32	0.89-0.84	76-77	5.1-6.5
SPK 4-19/10	MG 80B	1.10	4.50-4.00/2.60-2.32	0.89-0.84	76-77	5.1-6.5

SPK with extension pipe

Pump type	Motor		Full load current $I_{1/1}$ [A]	Power factor $\cos \pi_{1/1}$	Motor efficiency ξ [%]	$\frac{I_{start}}{I_{1/1}}$
	Type	P_2 [kW]				
SPK 4-19/10	MG 80B	1.10	4.50-4.00/2.60-2.32	0.89-0.84	76-77	5.1-6.5

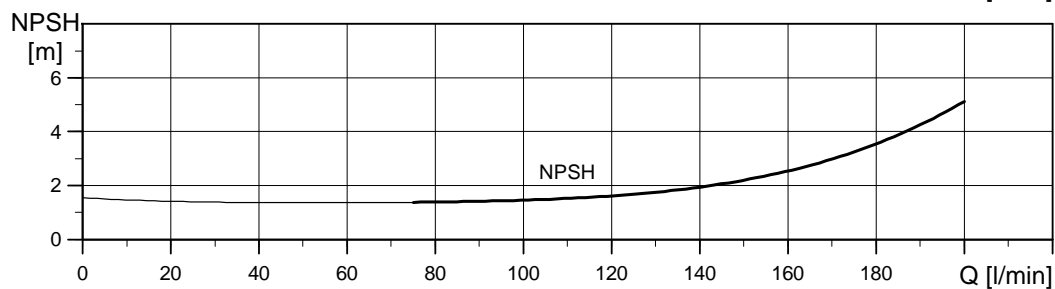
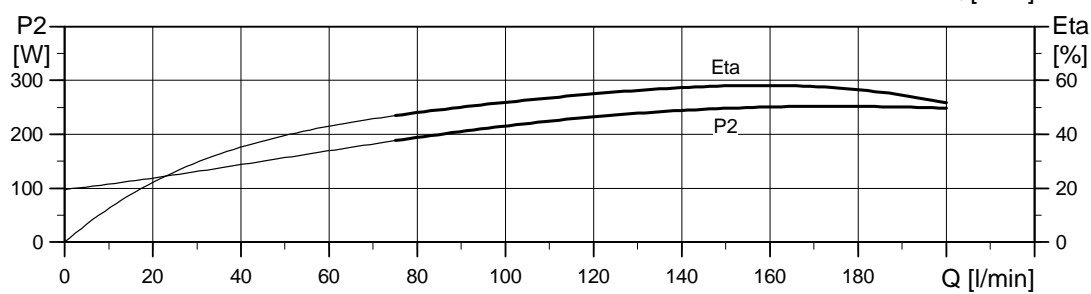
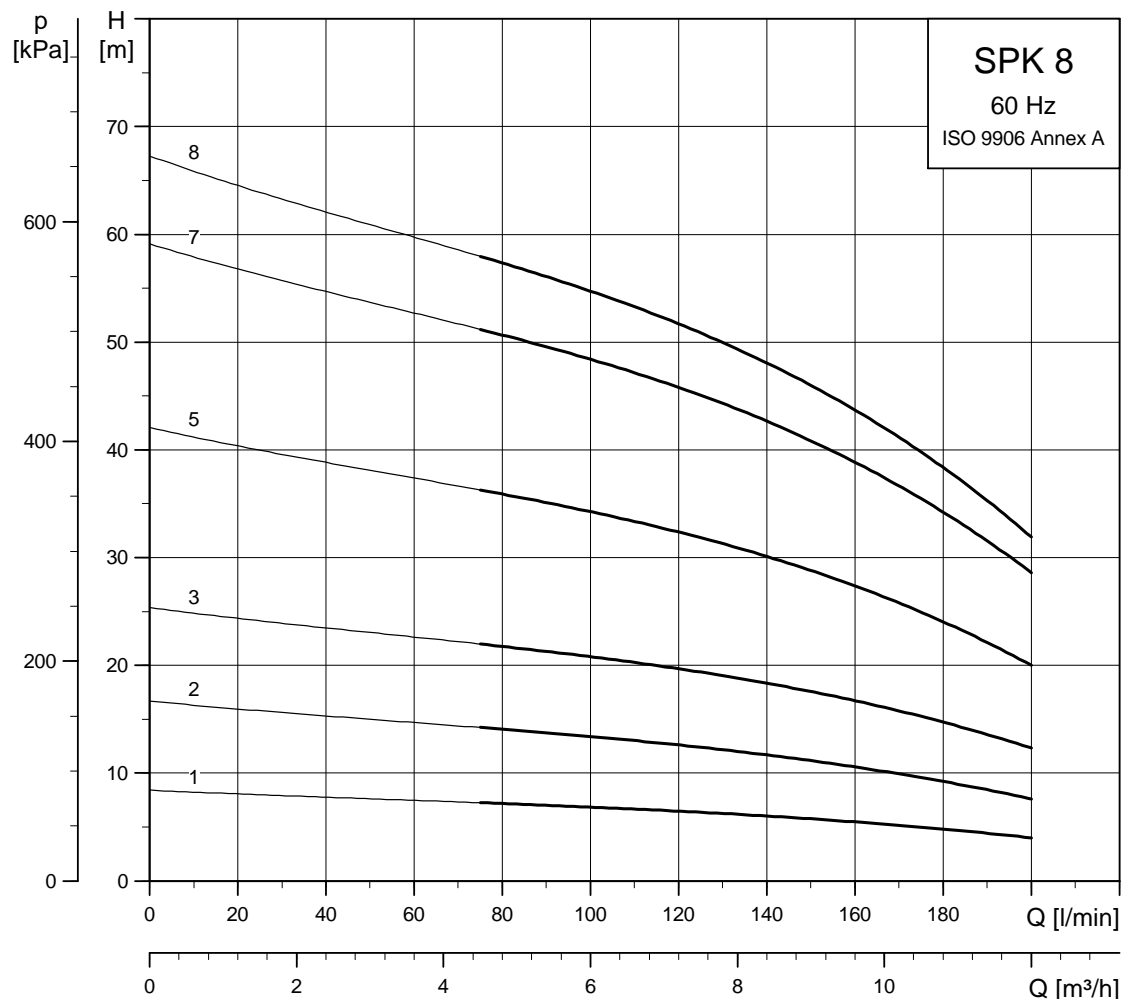

TM001937 3700

Dimensional sketches

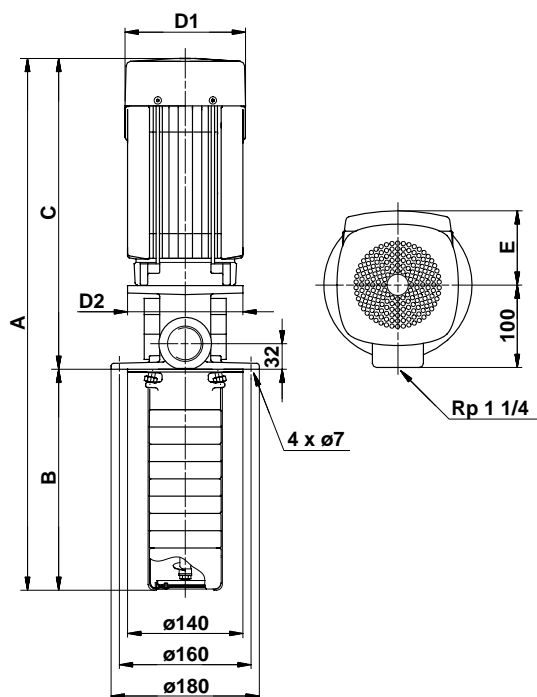

Dimensions and weights

Pump type	Dimensions [mm]						Weight [kg]*
	A	B	C	D1	D2	E	
SPK 8-1/1	475	182	293	142	140	109	12.2
SPK 8-2/2	517	224	293	142	140	109	13.1
SPK 8-3/3	599	266	333	142	140	109	16.3
SPK 8-5/5	734	350	384	178	140	110	23.6
SPK 8-7/7	818	434	384	178	140	110	26.4
SPK 8-9/8	902	518	384	178	140	110	28.4
SPK 8-12/8	1025	644	384	178	140	110	29.0
SPK 8-15/8	1154	770	384	178	140	110	29.5

* The stated weights apply to SPK only. For SPKI, add 1.3 kg.

SPK with extension pipe

Pump type	Dimensions [mm]						Weight [kg]*
	A	B	C	D1	D2	E	
SPK 8-15/8	1389	1005	384	178	140	110	32.5

* The stated weights apply to SPK only. For SPKI, add 1.3 kg.

Electrical data

3 x 220-255/380-440 V, 60 Hz

Pump type	Motor		Full load current $I_{1/1}$ [A]	Power factor $\cos \pi_{1/1}$	Motor efficiency ξ [%]	$\frac{I_{start}}{I_{1/1}}$
	Type	P_2 [kW]				
SPK 8-1/1	MG 71A	0.37	1.58-1.46/0.91-0.84	0.88-0.82	72-73	4.8-6.0
SPK 8-2/2	MG 71B	0.55	2.40-2.18/1.38-1.26	0.88-0.82	71-72	4.8-6.0
SPK 8-3/3	MG 80B	1.1	4.50-4.00/2.60-2.32	0.89-0.84	76-77	5.1-6.5

Electrical data

3 x 220-277/380-480 V, 60 Hz

SPK 8-5/5	MG 90SA	1.5	5.70-5.00/3.30-2.90	0.89-0.78	80.5-82.0	5.9-8.4
SPK 8-7/7	MG 90LA	2.2	8.05-6.95/4.65-4.00	0.90-0.81	83-84.5	6.5-9.5
SPK 8-9/8	MG 90LA	2.2	8.05-6.95/4.65-4.00	0.90-0.81	83-84.5	6.5-9.5
SPK 8-12/8	MG 90LA	2.2	8.05-6.95/4.65-4.00	0.90-0.81	83-84.5	6.5-9.5
SPK 8-15/8	MG 90LA	2.2	8.05-6.95/4.65-4.00	0.90-0.81	83-84.5	6.5-9.5

SPK with extension pipe

Pump type	Motor		Full load current $I_{1/1}$ [A]	Power factor $\cos \pi_{1/1}$	Motor efficiency ξ [%]	$\frac{I_{start}}{I_{1/1}}$
	Type	P_2 [kW]				
SPK 8-15/8	MG 90LA	2.2	8.05-6.95/4.65-4.00	0.90-0.81	83-84.5	6.5-9.5

MTH, 50 Hz

Performance range

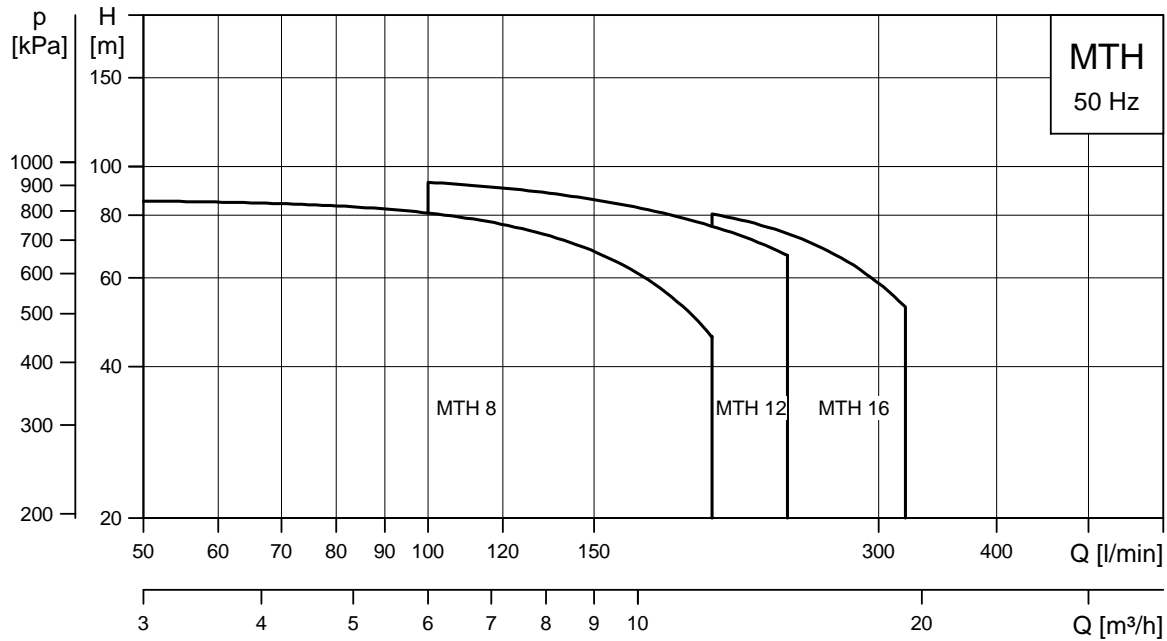

TM01.4465.0398

Product range

MTH 8

Example: MTH 8-60/6	Number of impellers						B [mm]
	2	3	4	5	6	7	
	20	·					60
	30	·	·				90
	40	·	·	·			120
	50	·	·	·	·		150
	60	·	·	·	·	·	180
	70	·	·	·	·	·	210
	P_1 [W]	1120	1530	1948	2369	2792	3219

MTH 16

Example: MTH 16-50/5	Number of impellers					B [mm]
	2	3	4	5		
	20	·				75
	30	·	·			120
	40	·	·	·		165
	50	·	·	·	·	210
	60	·	·	·	·	255
	P_1 [W]	2510	3374	4250	5163	

MTH 12

Example: MTH 12-60/5	Number of impellers				B [mm]	
	2	3	4	5		
	20	·			60	
	30	·	·		90	
	40	·	·	·		120
	50	·	·	·	·	150
	60	·	·	·	·	180
	70	·	·	·	·	210
P_1 [W]	2169	3264	4359	5454		

MTH, 60 Hz

Performance range

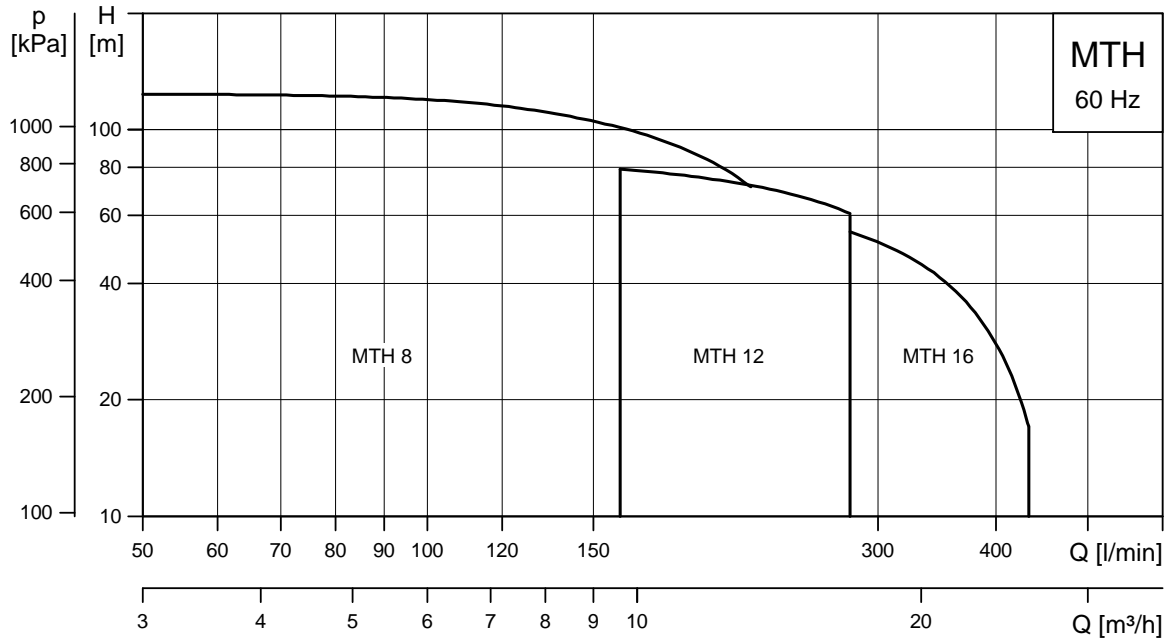

TM01.4466.0398

Product range

MTH 8

Example: MTH 8-60/6	Number of impellers						B [mm]
	2	3	4	5	6	7	
	20	·					60
	30	·					90
	40	·	·				120
	50	·	·	·			150
	60	·	·	·	·		180
	70	·	·	·	·	·	210
	P_1 [W]	1815	2500	3190	3885	4585	5285

MTH 16

Example: MTH 16-50/3	Number of impellers		B [mm]
	2	3	
	20	·	75
	30	·	120
	40	·	165
	50	·	210
	60	·	255
	P_1 [W]	3525	5377

MTH 12

Example: MTH 12-60/3	Number of impellers		B [mm]
	2	3	
	20	·	60
	30	·	90
	40	·	120
	50	·	150
	60	·	180
	70	·	210
P_1 [W]	3266	5680	

Product description

MTH is designed for pumping cooling lubricants for machine tools, condensate transfer and other purposes.

MTH is specially designed for applications offering only limited space for installation. Motor and pump form an integral, compact unit consisting of few components. The pump is designed for medium pressure.

The pump can be used for applications involving lathes, grinding machines, machining centres, cooling units, industrial washing machines, filtering systems, swarf conveyors etc.

Pumped liquids

Thin, clean, non-explosive liquids without abrasive particles or fibres. Both water and water-soluble coolants and cutting lubricants can be pumped.

Pump

The pump is a multistage, centrifugal pump with mechanical shaft seal according to DIN 24960. Mounting flange sizes according to DIN 5440. To meet specific depths of tanks or containers, the installation length of the pump can be varied using empty chambers. # Available variants are based on the number of stages indicated in the Dimensions and weights tables.

Motor

The pump is fitted with a totally enclosed, fan-cooled motor with principal dimensions according to IEC, DIN and British standards.

- Enclosure class : IP 54#
- Insulation class : F#
- Standard voltages, 50 Hz: 3 x 220 - 240/380 - 415 V#
3 x 200 - 220/346 - 380 V#
- Standard voltages, 60 Hz: 3 x 200 - 230/346 - 400 V#
3 x 208 - 230/460 V #
3 x 220 - 277/380 - 480 V.

Max. ambient temperature

Due to the low density and consequently low cooling effect of the air, operation at an ambient temperature above 40°C or at an altitude exceeding 1000 m above sea level requires a reduction of P2.

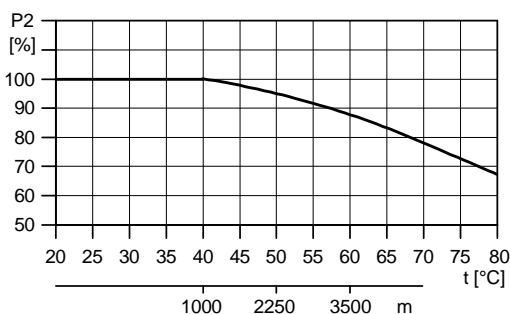

TM00 2189 4298

Example:#

From the above figure appears that P2 must be reduced to 88% when the pump is installed 3500 m above sea level. At an ambient temperature of 70°C, P2 must be reduced to 80% of rated output.

Sound pressure level

Motor P ₁ [W]	50 Hz		60 Hz	
	L _{pA} [dB(A)]	Motor P ₁ [W]	L _{pA} [dB(A)]	Motor P ₁ [W]
1120-3264	<70	1805	<70	
1120-3264	<70	2500-5377	71	
1120-3264	<70	2500-5377	71	
1120-3264	<70	2500-5377	71	
1120-3264	<70	2500-5377	71	
1120-3264	<70	2500-5377	71	
1120-3264	<70	2500-5377	71	
1120-3264	<70	2500-5377	71	
1120-3264	<70	2500-5377	71	
1120-3264	<70	2500-5377	71	
1120-3264	<70	2500-5377	71	
4359-5163	73	2500-5377		
4359-5163	73	2500-5377		
4359-5163	73	2500-5377		
4359-5163	73	2500-5377		

Shaft seal

Max. operating pressure and liquid temperature for the shaft seal

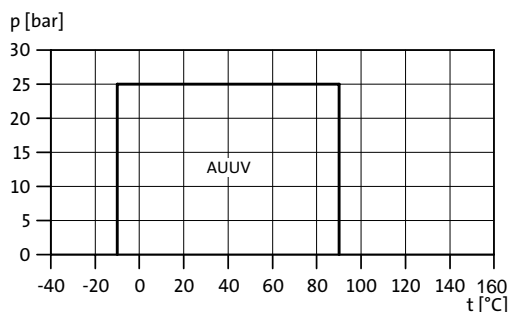

TM03 0023 3804

Type key

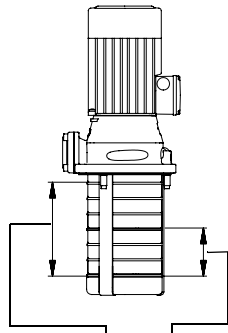

Example	MTH	8	-	60	/	3	A	-	W	-	A	AUUV
Pump type												
Nominal flow [m ³ /h]												
Number of chambers x 10												
Number of impellers# (ref. to performance curve and motor size)												
Pump version# A : Basic												
Connection code												
Materials# A : Basic												
Shaft seal												

Installation

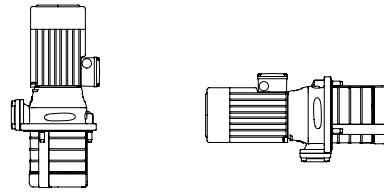

TM00 4988 1399

To enable a very low liquid level of 40 mm above the bottom of the strainer, a priming screw is fitted below the bottom intermediate chamber. This protects the pump against dry running down to 25 mm above the bottom of the strainer.

Distance between pump and tank bottom must be minimum 25 mm.

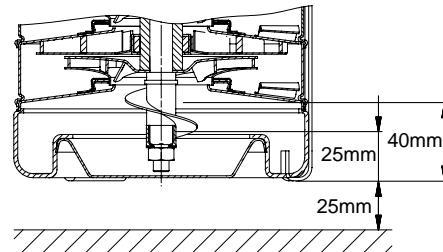

TM01 7809 4899

Materials

Pos. no.	Description	Materials	DIN W.-Nr.	AISI/ASTM
2	Motor stool	Cast iron# EN-GJL-200	0.6020	ASTM 25B
3	Chamber without guide vanes	Stainless steel	1.4301	AISI 304
3a	Chamber without guide vanes	Stainless steel	1.4401	AISI 316
4	Chamber complete	Stainless steel	1.4401	AISI 316
4a	Chamber complete with bearing	Stainless steel	1.4301	AISI 304
12	Flange	Cast iron# EN-GJL-200	0.6020	ASTM 25B
26	Strap	Stainless steel	1.4301	AISI 304
35	Hexagon socket head screw	Stainless steel	1.4401	AISI 316
36	Hexagon socket head screw	Stainless steel	1.4401	AISI 316
37	Gasket	Paper		
44	Inlet part complete	Stainless steel	1.4301	AISI 304
45	Neck ring	PFTE		
45b	Neck ring	PFTE		
49	Impeller	Stainless steel	1.4301	AISI 304
49c	Wear ring	Stainless steel	1.4301	AISI 304
49d	Impeller	Stainless steel	1.4401	AISI 316
62	Stop ring	Stainless steel	1.4401	AISI 316
64	Spacing pipe	Stainless steel	1.4301	AISI 316
64a	Spacing pipe	Stainless steel	1.4301	AISI 316
64c	Spacing pipe	Stainless steel	1.4301	AISI 316
65	Retainer for neck ring	Stainless steel	1.4301	AISI 304
65a	Retainer for neck ring	Stainless steel	1.4301	AISI 304
66	Washer	Stainless steel	1.4301	AISI 304
67	Lock nut	Stainless steel	1.4301	AISI 304
79	Diverting disc	Rubber		
84	Strainer:# MTH 2 and 4, ϕ 2 mm holes# MTH 8, 12 and 16, ϕ 4 mm holes	Stainless steel	1.4301	AISI 304
84a	Retainer for strainer	Stainless steel	1.4301	AISI 304
102	O-ring	FKM		
103	Upper seal ring	Wolfram carbide		
104	Lower seal ring	Wolfram carbide		
105	Shaft seal			
107	O-ring	FKM		
108	Spring	Stainless steel	1.4301	AISI 304
111	Spring retainer	Stainless steel	1.4301	AISI 304
112	Spacer	Stainless steel	1.4301	AISI 304
122	Priming screw	Stainless steel	1.4401	AISI 316
151	Fan cover			
152	Screw	Stainless steel	1.4301	AISI 304
156	Fan			
156a	End shield			
158	Corrugated spring			
159	O-ring	Rubber		
164	Terminal box cover			
172	Pump-motor shaft complete	Pump: stainless steel	1.4401	AISI 316
		Motor: steel	1.0533	

Sectional drawing MTH 8

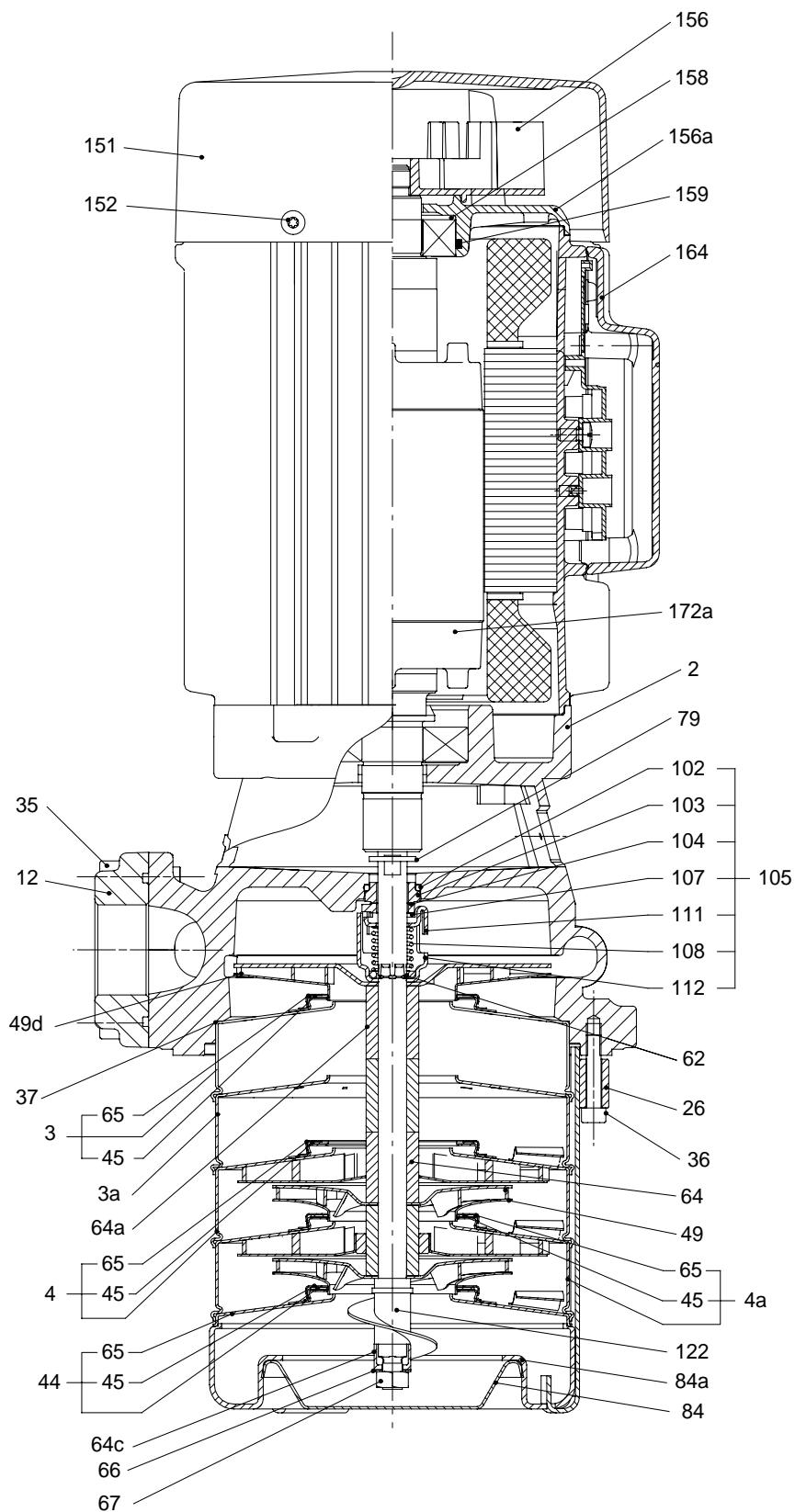

TM016387 2299

Sectional drawing MTH 12

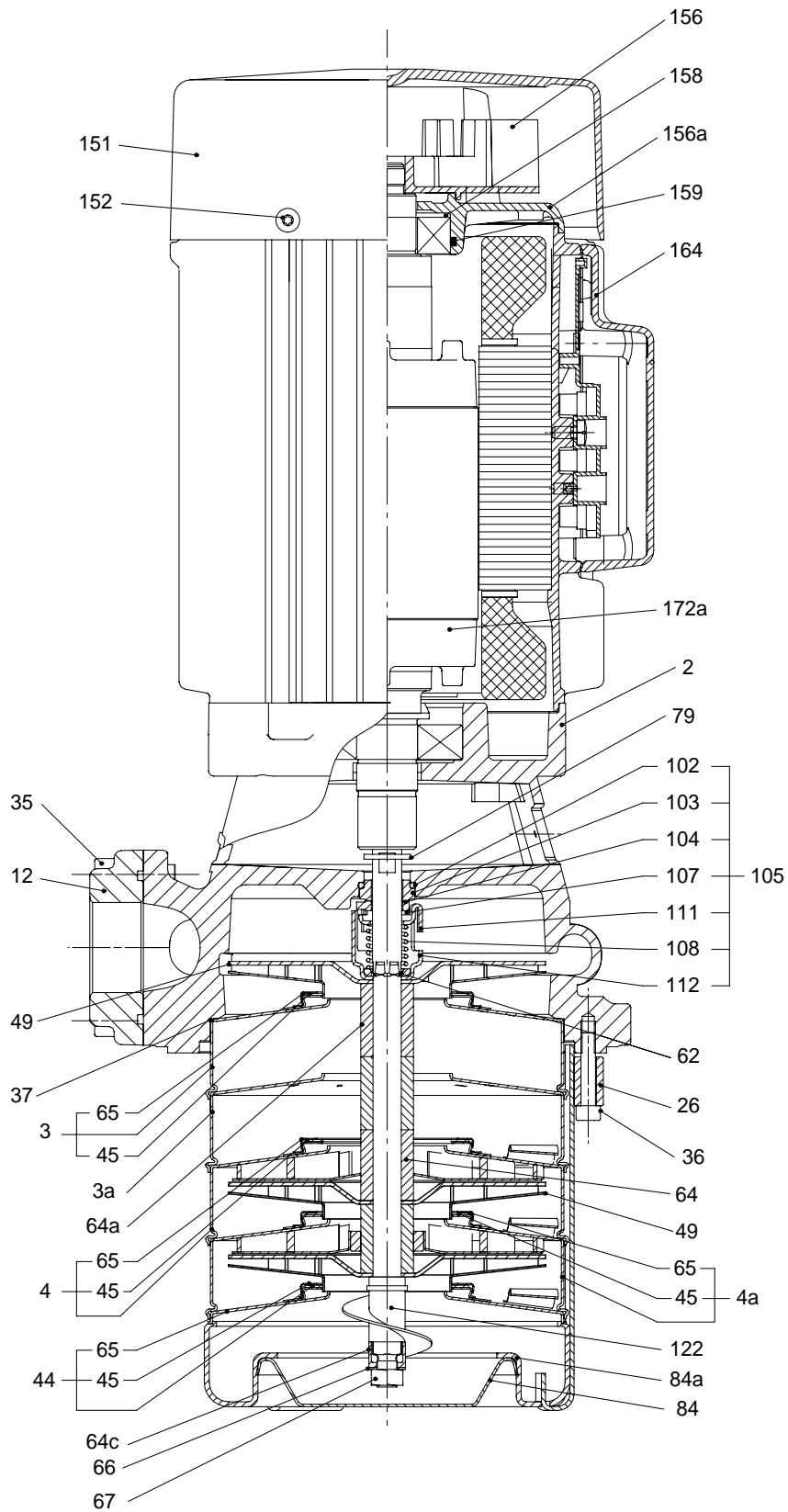

TM016377 2199

Sectional drawing MTH 16

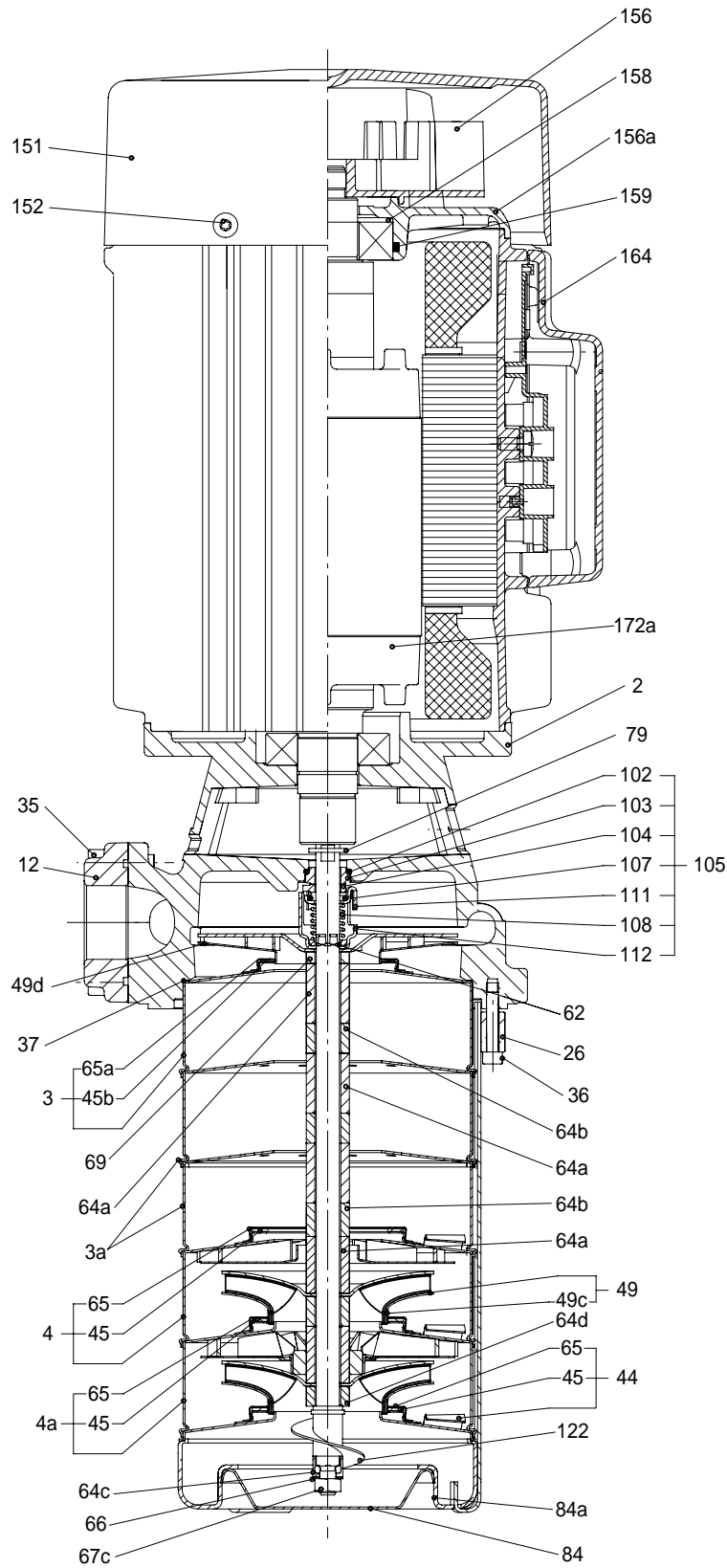

TM016254 2099

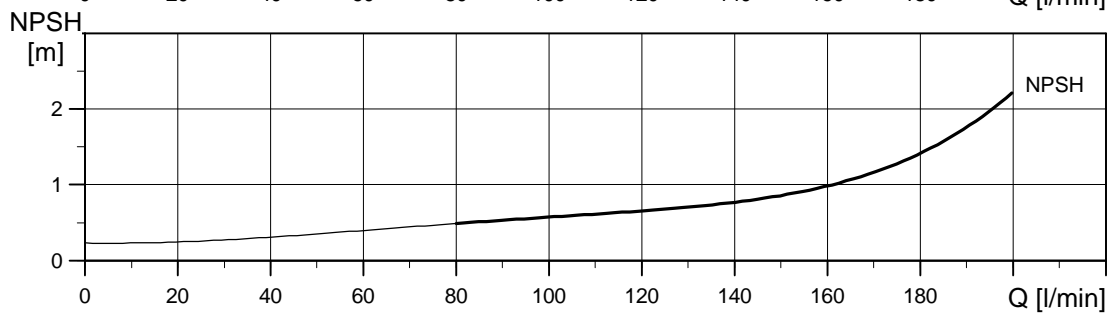
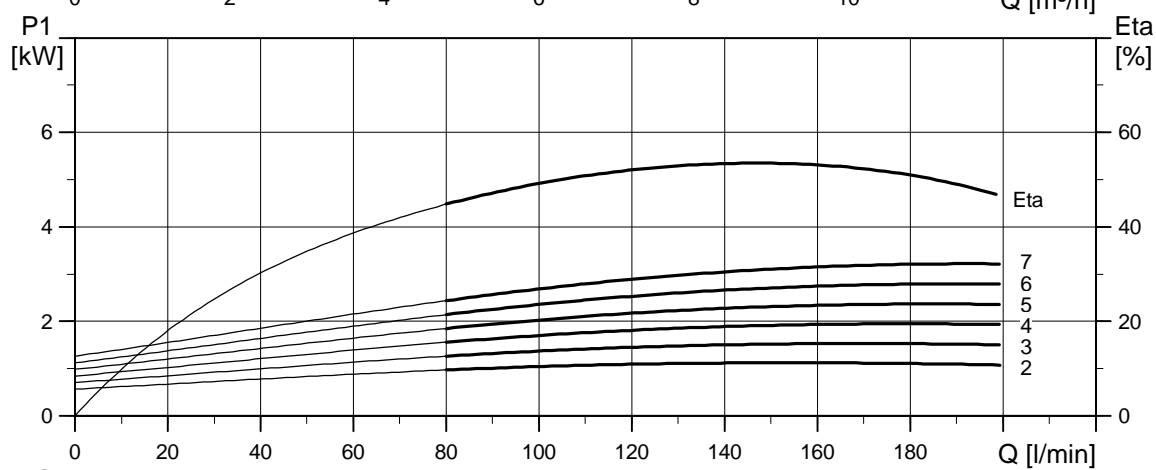
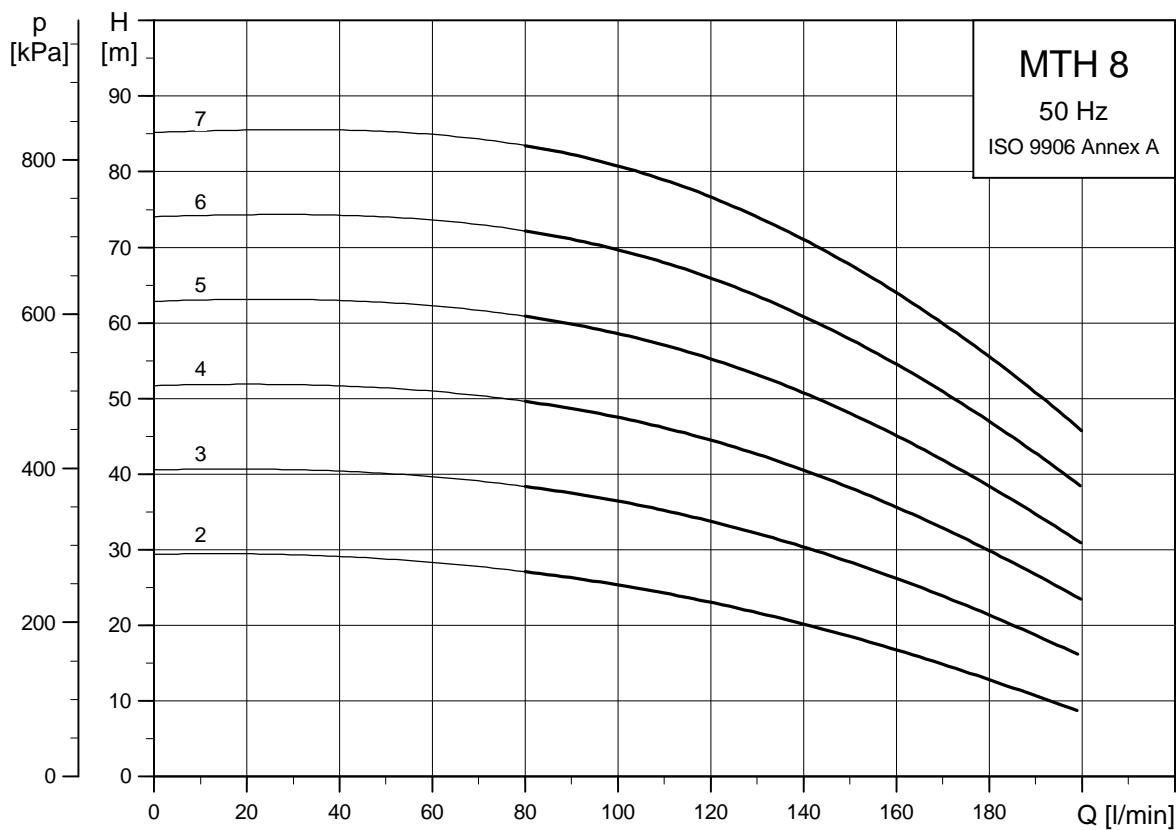

TM001 4296 3700

Dimensional sketches

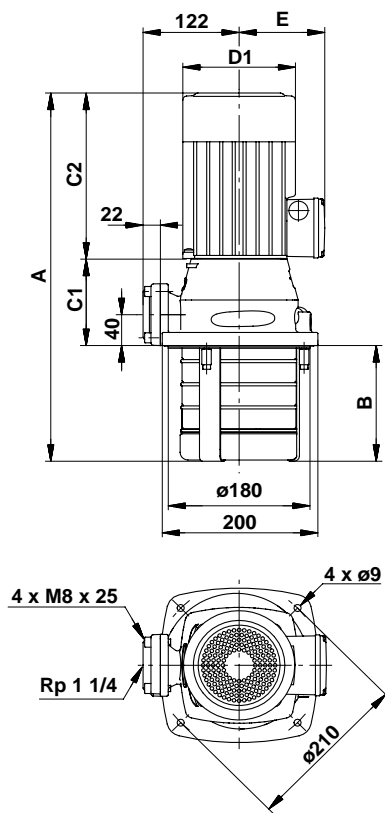

TM01 4199 1800

Dimensions and weights

Pump type	Dimensions [mm]						Weight [kg]
	A	B	C1	C2	D1	E	
MTH 8-20/2	391	60	141	218	142	109	20
MTH 8-30/3	486	90	141	255	178	110	22
MTH 8-40/4	516	120	141	255	178	110	29
MTH 8-50/5	546	150	141	255	178	110	33
MTH 8-60/6	576	180	141	255	178	110	34
MTH 8-70/7	645	210	141	294	178	110	36

Electrical data

3 x 220-240/380-415 V, 50 Hz

Pump type	Motor P_1 [W]	Full load current $I_{1/1}$ [A]	Power factor $\cos \pi_{1/1}$	Motor efficiency ξ [%]	$\frac{I_{start}}{I_{1/1}}$
MTH 8-20/2	1120	4.11/2.15	0.87-0.79	76	5.2-5.7
MTH 8-30/3	1530	5.30/3.06	0.85-0.79	82	6.3-6.9
MTH 8-40/4	1948	6.16/3.55	0.85-0.79	82	6.3-6.9
MTH 8-50/5	2369	7.10/4.10	0.87-0.82	84	7.0-7.6
MTH 8-60/6	2792	8.08/4.67	0.87-0.82	84	7.0-7.6
MTH 8-70/7	3219	9.53/5.50	0.88-0.82	86	7.8-8.5

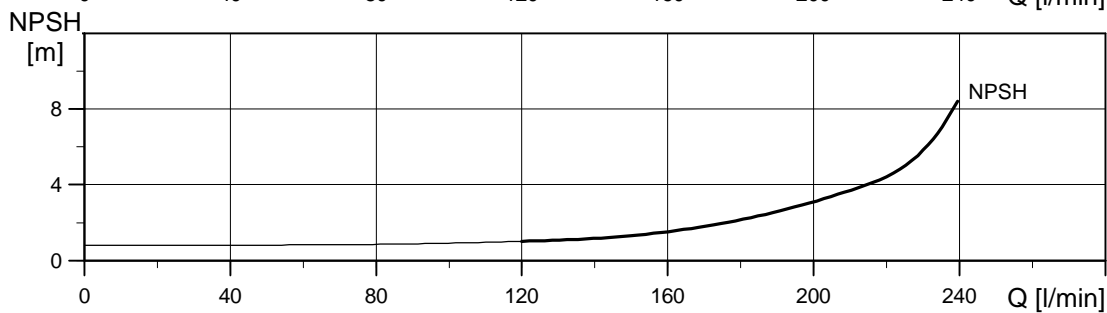
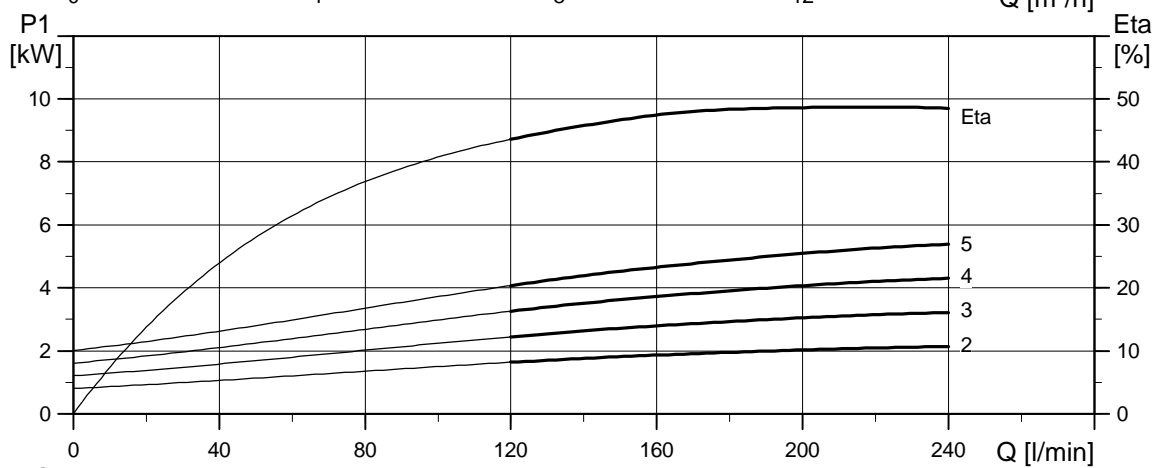
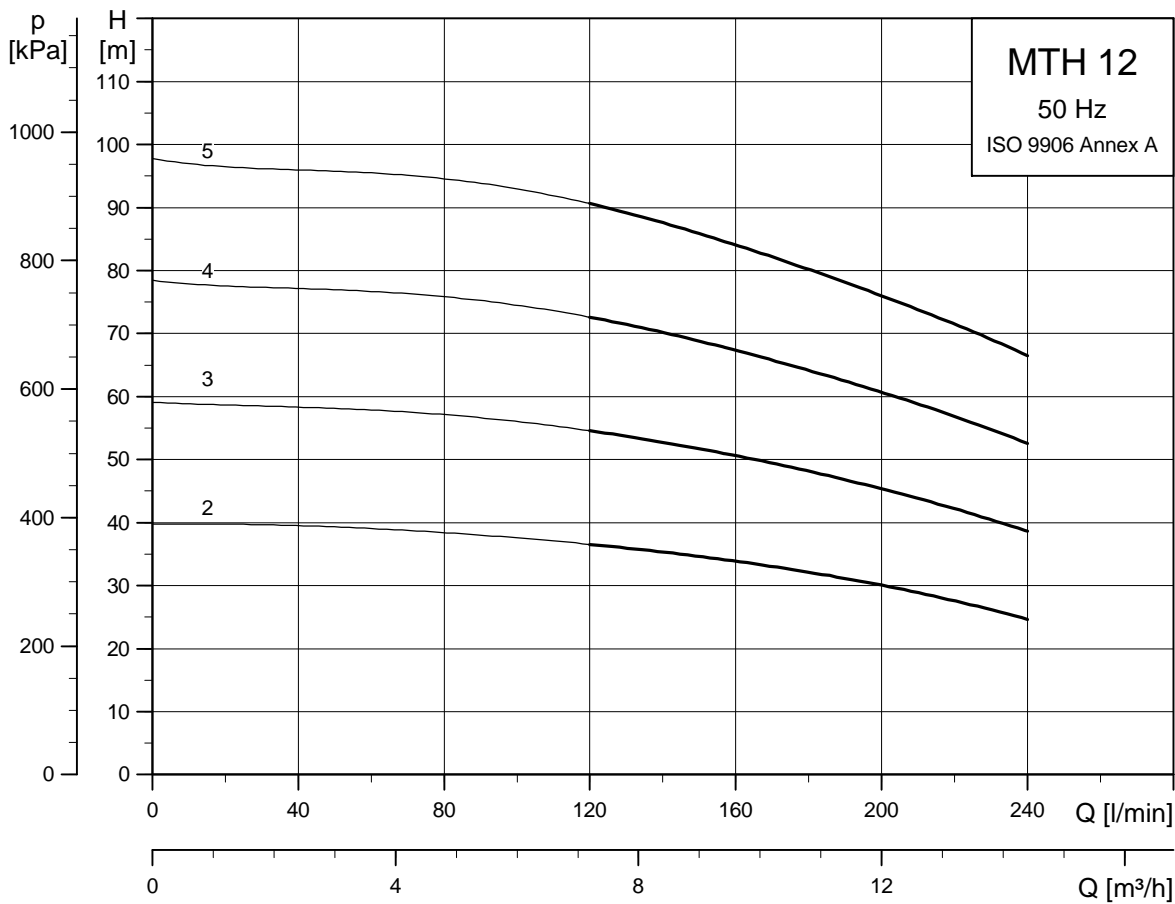

TM01.4297.3700

Dimensional sketches

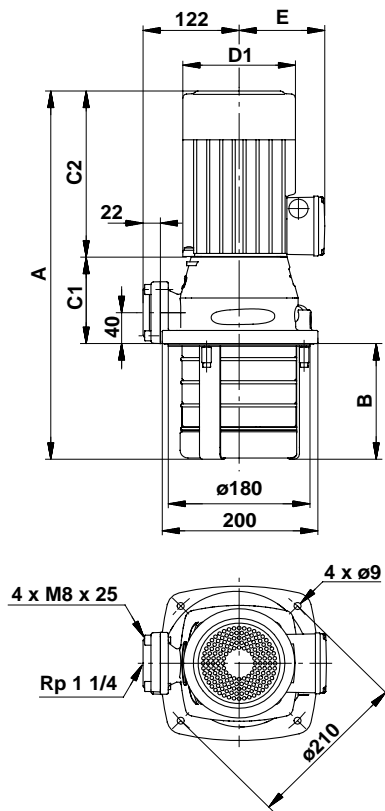

TM01 4199 1800

Dimensions and weights

Pump type	Dimensions [mm]						Weight [kg]
	A	B	C1	C2	D1	E	
MTH 12-20/2	456	60	141	255	178	110	27
MTH 12-30/3	525	90	141	294	178	110	30
MTH 12-40/4	595	120	141	334	220	134	35
MTH 12-50/5	635	150	141	334	220	134	48
MTH 12-60/5	655	180	141	334	220	134	49
MTH 12-70/5	685	210	141	334	220	134	50

Electrical data

3 x 220-240/380-415 V, 50 Hz

Pump type	Motor P_1 [W]	Full load current $I_{1/1}$ [A]	Power factor $\cos \pi_{1/1}$	Motor efficiency ξ [%]	$\frac{I_{start}}{I_{1/1}}$
MTH 12-20/2	2169	6.64/3.83	0.87-0.82	84	7.0-7.6
MTH 12-30/3	3264	9.63/5.56	0.88-0.82	86	7.8-8.5
MTH 12-40/4	4359	12.5/7.22	0.90-0.87	87	8.7-9.5
MTH 12-50/5	5454	15.2/8.77	0.90-0.87	87	8.7-9.5
MTH 12-60/5	5454	15.2/8.77	0.90-0.87	87	8.7-9.5
MTH 12-70/5	5454	15.2/8.77	0.90-0.87	87	8.7-9.5

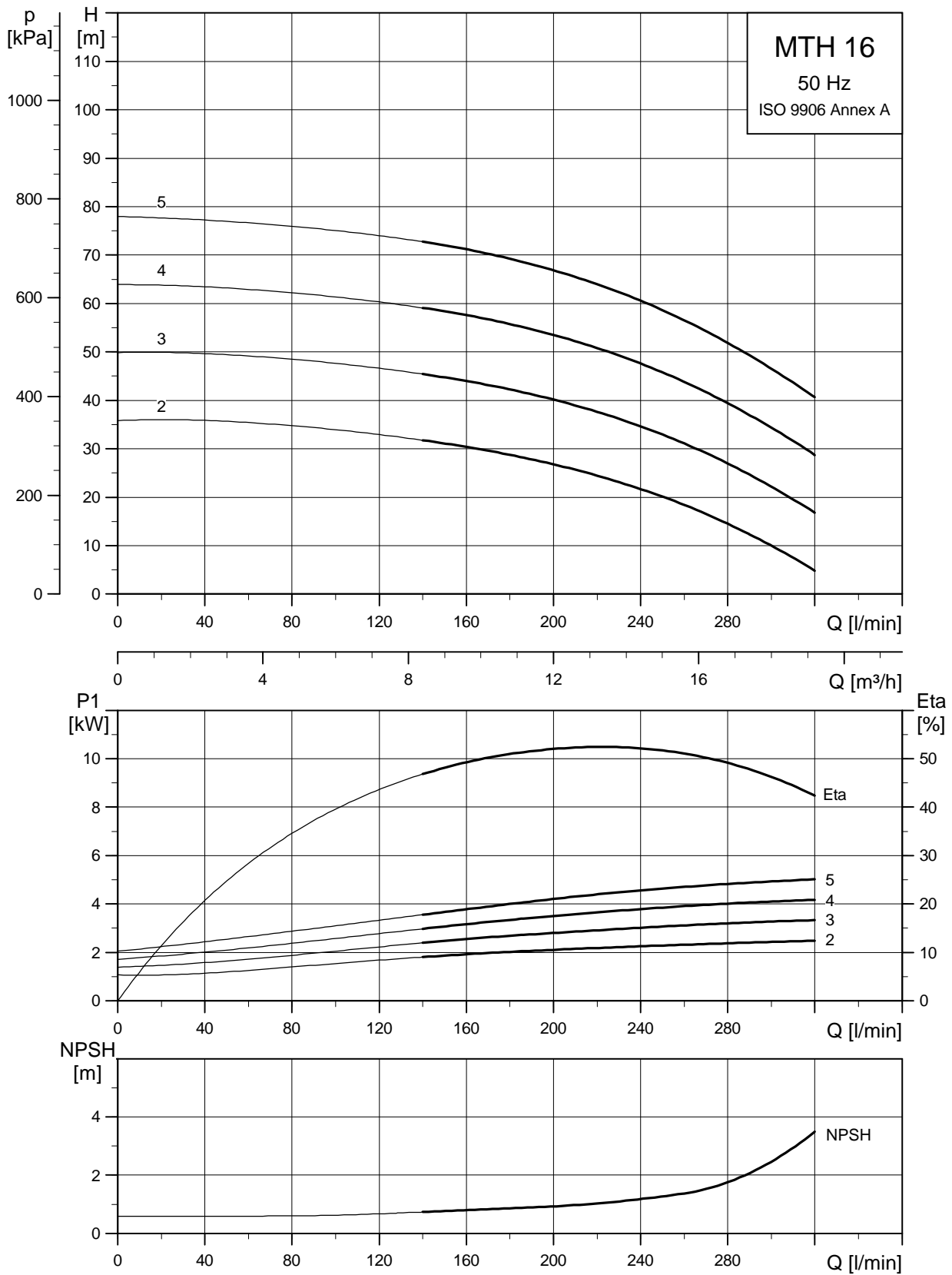

TM00 1930 3700

Dimensional sketches

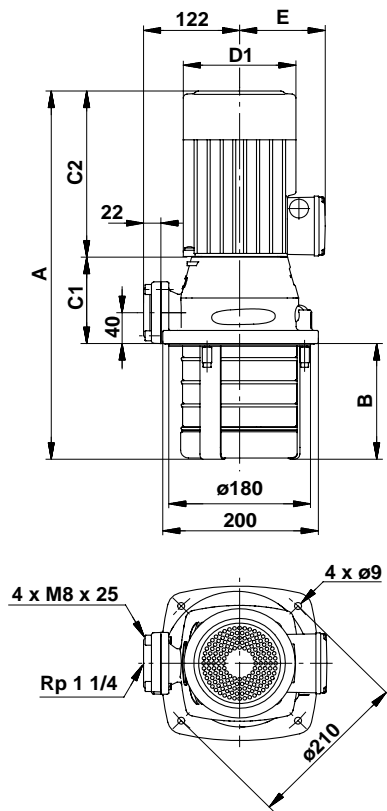

TM01.4199.1800

Dimensions and weights

Pump type	Dimensions [mm]						Weight [kg]
	A	B	C1	C2	D1	E	
MTH 16-20/2	471	75	141	255	178	110	34
MTH 16-30/3	555	120	141	294	178	110	38
MTH 16-40/4	640	165	141	334	220	134	40
MTH 16-50/5	685	210	141	334	220	134	63
MTH 16-60/5	730	255	141	334	220	134	64

Electrical data

3 x 220-240/380-415 V, 50 Hz

Pump type	Motor P_1 [W]	Full load current $I_{1/1}$ [A]	Power factor $\cos \pi_{1/1}$	Motor efficiency ξ [%]	$\frac{I_{start}}{I_{1/1}}$
MTH 16-20/2	2510	7.42/4.28	0.85-0.79	82	6.3-6.9
MTH 16-30/3	3374	9.89/5.71	0.88-0.82	86	7.8-8.5
MTH 16-40/4	4250	12.3/7.07	0.90-0.87	87	8.7-9.5
MTH 16-50/5	5163	14.5/8.35	0.90-0.87	87	8.7-9.5
MTH 16-60/5	5163	14.5/8.35	0.90-0.87	87	8.7-9.5

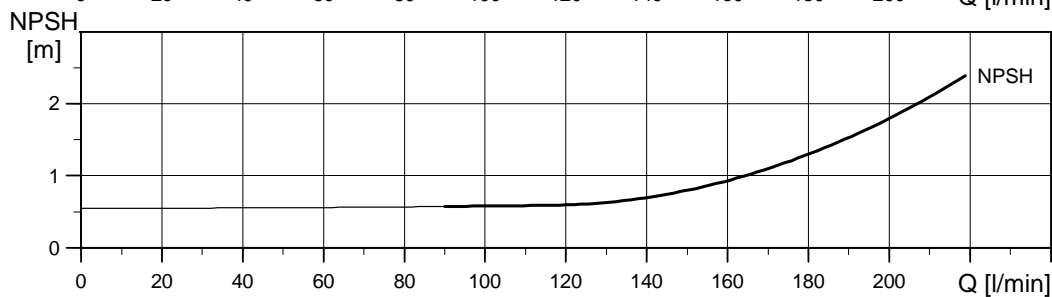
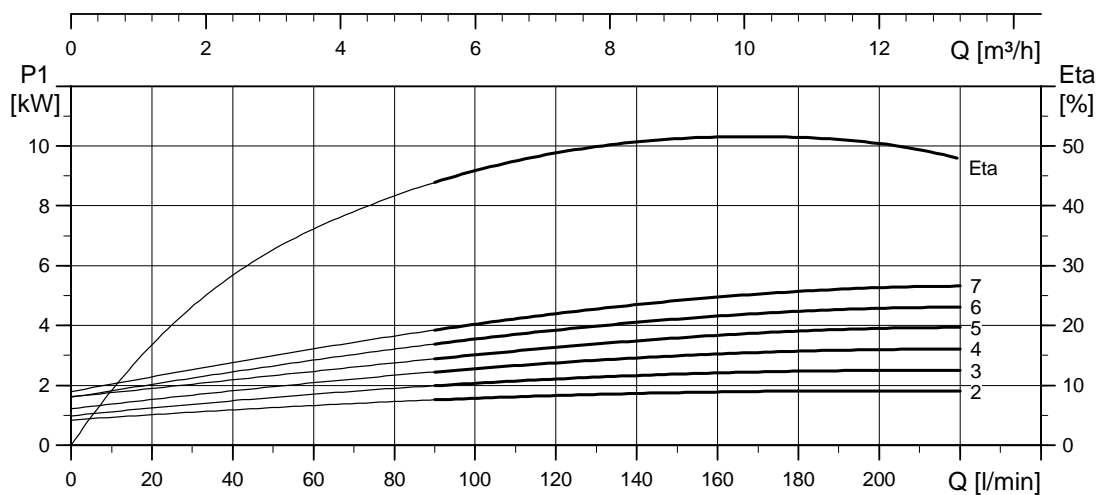
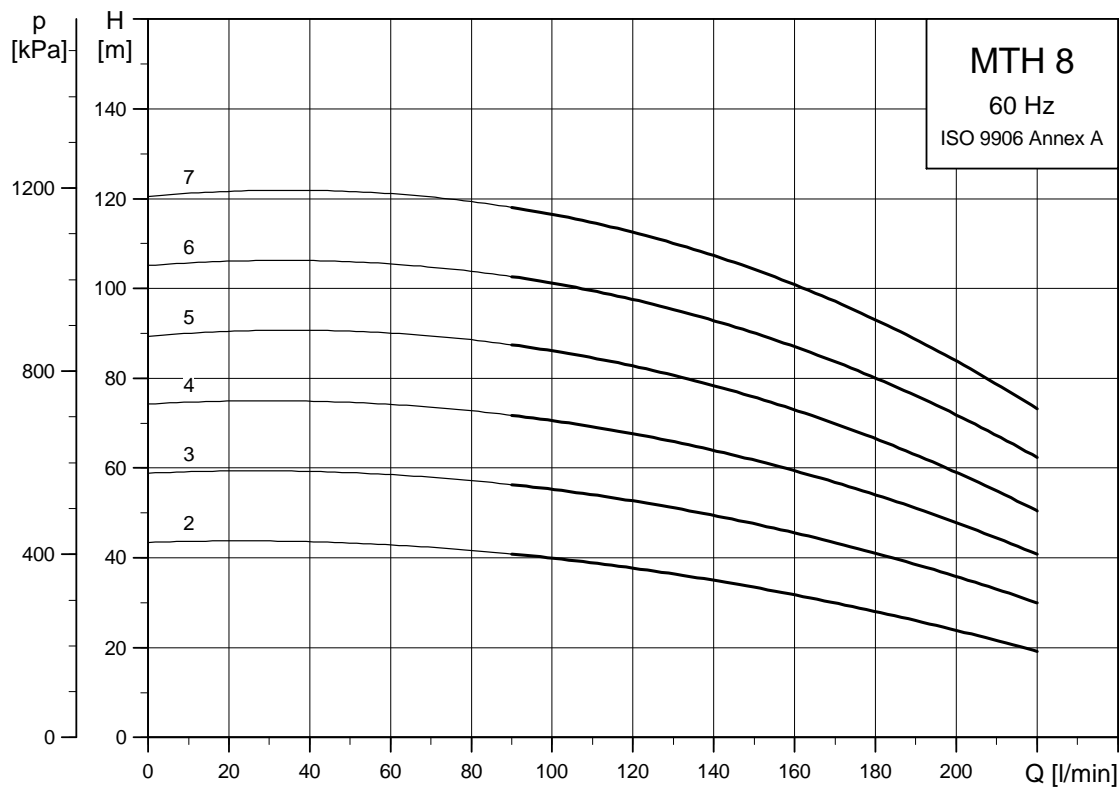

TM01.4299.4699

Dimensional sketches

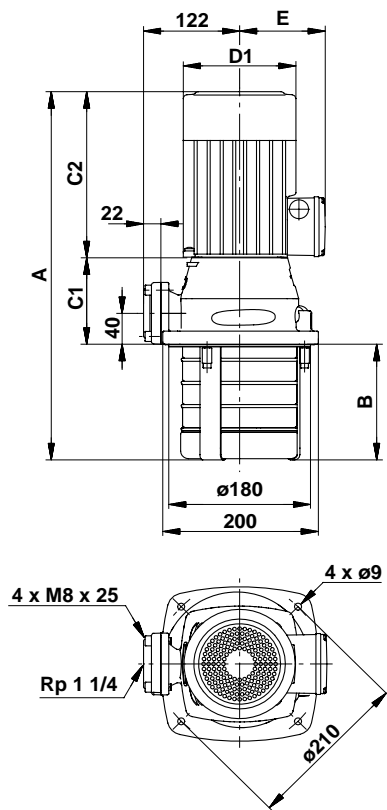

TM01 41991800

Dimensions and weights

Pump type	Dimensions [mm]						Weight [kg]
	A	B	C1	C2	D1	E	
MTH 8-20/2	486	90	141	255	178	109	29
MTH 8-30/3	486	90	141	255	178	100	32
MTH 8-40/4	555	120	141	294	178	110	36
MTH 8-50/5	585	150	141	294	178	100	39
MTH 8-60/6	655	180	141	334	220	134	40
MTH 8-70/7	685	210	141	334	220	134	45

Electrical data

3 x 208-230/460 V, 60 Hz

Pump type	Motor P ₁ [W]	Full load current I _{1/1} [A]	Power factor Cos π _{1/1}	Motor efficiency ξ [%]	I _{start} I _{1/1}
MTH 8-20/2	1815	6.13-5.78/2.90	0.89-0.82	80.5-82.0	5.9-7.4
MTH 8-30/3	2496	8.54-8.28/4.14	0.90-0.85	83.0-84.5	6.5-8.3
MTH 8-40/4	3187	11.0-10.28/5.14	0.90-0.86	86.0-87.0	7.4-9.5
MTH 8-50/5	3884	13.0-12.14/6.10	0.90-0.86	86.0-87.0	7.4-9.5
MTH 8-60/6	4583	15.31-14.31/7.20	0.92-0.88	87.0-88.0	8.0-10.4
MTH 8-70/7	5282	17.50-16.20/8.10	0.92-0.88	87.0-88.0	8.0-10.4

3 x 200-230/346-400 V, 60 Hz

MTH 8-20/2	1815	6.22/3.60	0.89-0.82	80.5-82.0	5.9-7.4
MTH 8-30/3	2496	7.90/4.54	0.90-0.85	83.0-84.5	6.5-8.3
MTH 8-40/4	3187	10.00/5.80	0.90-0.86	86.0-87.0	7.4-9.5
MTH 8-50/5	3884	12.14/7.01	0.90-0.86	86.0-87.0	7.4-9.5
MTH 8-60/6	4583	12.80/7.40	0.92-0.88	87.0-88.0	8.0-10.4
MTH 8-70/7	5282	15.31/8.84	0.92-0.88	87.0-88.0	8.0-10.4

3 x 220-277/380-480 V, 60 Hz

MTH 8-20/2	1815	5.70/3.30	0.89-0.78	80.5-82.0	5.90-8.40
MTH 8-30/3	2496	7.15/4.13	0.90-0.81	83.0-84.5	6.50-9.50
MTH 8-40/4	3187	9.10/5.23	0.90-0.83	86.0-87.0	7.40-11.0
MTH 8-50/5	3884	11.04/6.40	0.90-0.83	86.0-87.0	7.40-11.0
MTH 8-60/6	4583	11.62/6.71	0.92-0.85	87.0-88.0	8.00-12.0
MTH 8-70/7	5282	14.73/8.50	0.90-0.85	87.0-88.0	8.00-12.0

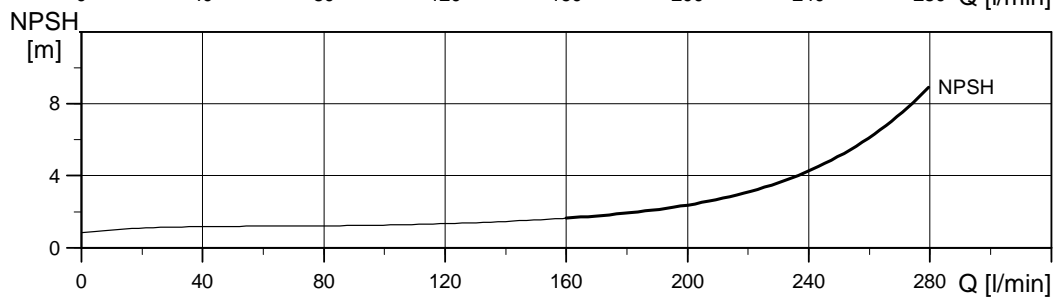
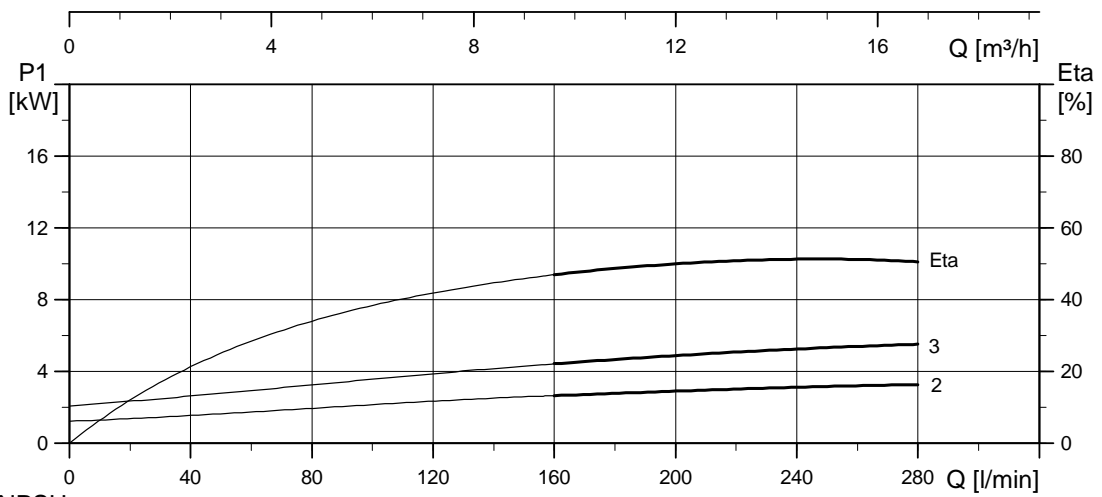
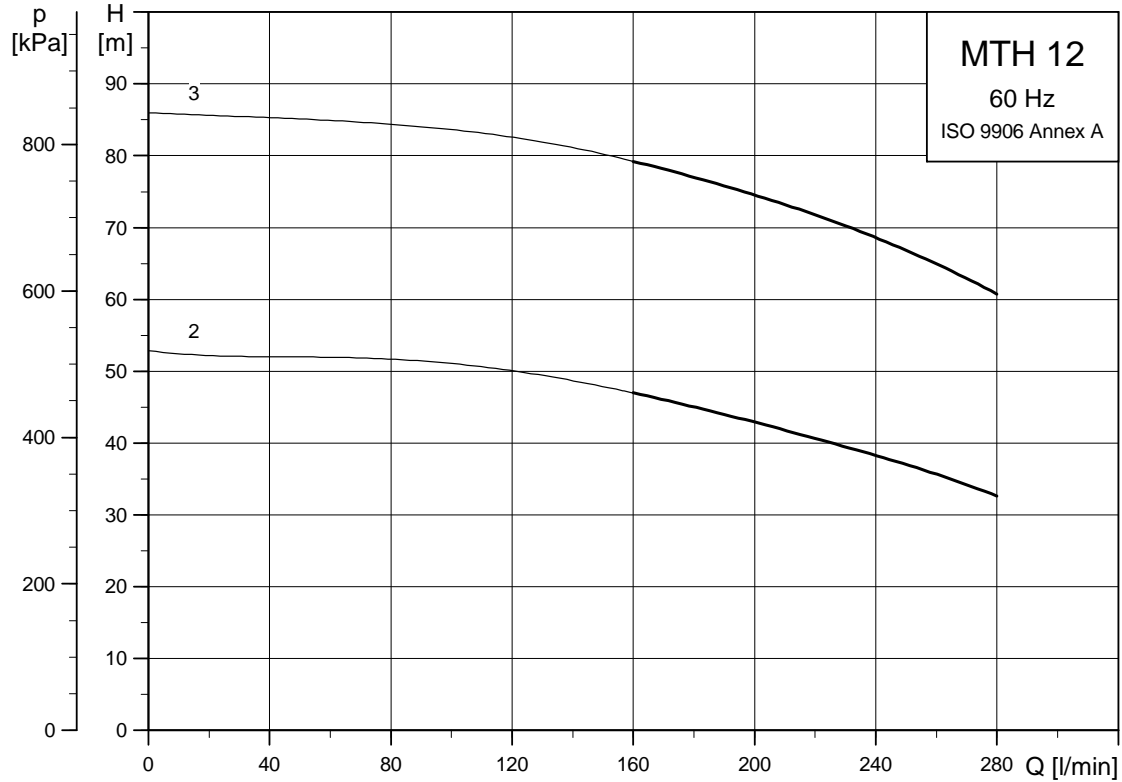

TM01 4300 3700

Dimensional sketches

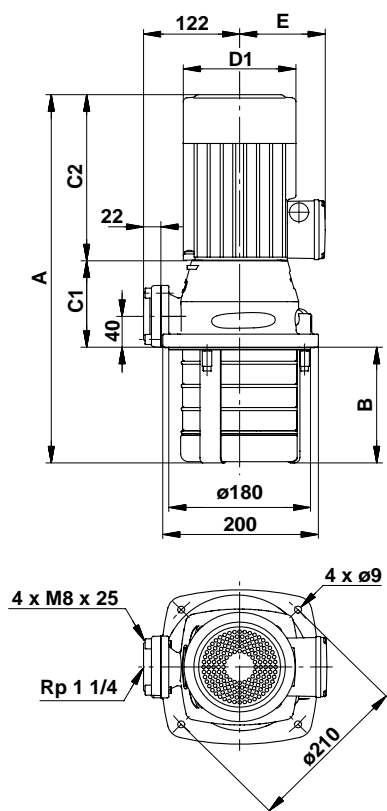

Dimensions and weights

Pump type	Dimensions [mm]						Weight [kg]
	A	B	C1	C2	D1	E	
MTH 12-20/2	495	60	141	294	178	110	37
MTH 12-30/3	572	90	141	341	220	134	47
MTH 12-40/3	602	120	141	341	220	134	48
MTH 12-50/3	632	150	141	341	220	134	49
MTH 12-60/3	662	180	141	341	220	134	50
MTH 12-70/3	692	210	141	341	220	134	51

Electrical data

3 x 208-230/460 V, 60 Hz

Pump type	Motor P ₁ [W]	Full load current I _{1/1} [A]	Power factor Cos π _{1/1}	Motor efficiency ξ [%]	I _{start} / I _{1/1}
MTH 12-20/2	3266	11.10-10.50/5.25	0.90-0.86	86.0-87.0	7.40-9.5
MTH 12-30/3	5678	19.22-18.40/9.20	0.92-0.88	87.5-89.5	8.2-10.7
MTH 12-40/3	5678	19.22-18.40/9.20	0.92-0.88	87.5-89.5	8.2-10.7
MTH 12-50/3	5678	19.22-18.40/9.20	0.92-0.88	87.5-89.5	8.2-10.7
MTH 12-60/3	5678	19.22-18.40/9.20	0.92-0.88	87.5-89.5	8.2-10.7
MTH 12-70/3	5678	19.22-18.40/9.20	0.92-0.88	87.5-89.5	8.2-10.7

3 x 200-230/346-400 V, 60 Hz

Pump type	Motor P ₁ [W]	Full load current I _{1/1} [A]	Power factor Cos π _{1/1}	Motor efficiency ξ [%]	I _{start} / I _{1/1}
MTH 12-20/2	3266	10.20/5.90	0.90-0.86	86.0-87.0	7.4-9.5
MTH 12-30/3	5678	17.42/10.10	0.92-0.88	87.5-89.5	8.2-10.7

3 x 220-277/380-480 V, 60 Hz

Pump type	Motor P ₁ [W]	Full load current I _{1/1} [A]	Power factor Cos π _{1/1}	Motor efficiency ξ [%]	I _{start} / I _{1/1}
MTH 12-20/2	3266	9.24/5.34	0.90-0.83	86.0-87.0	7.40-11.0
MTH 12-30/3	5678	15.84/9.14	0.93-0.86	81.0-83.0	5.90-7.50

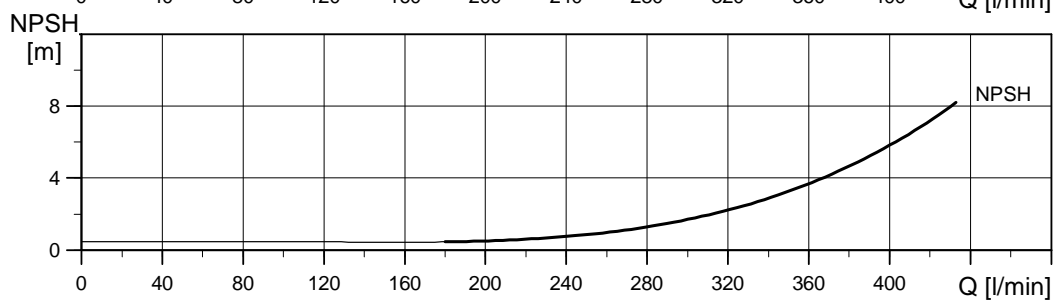
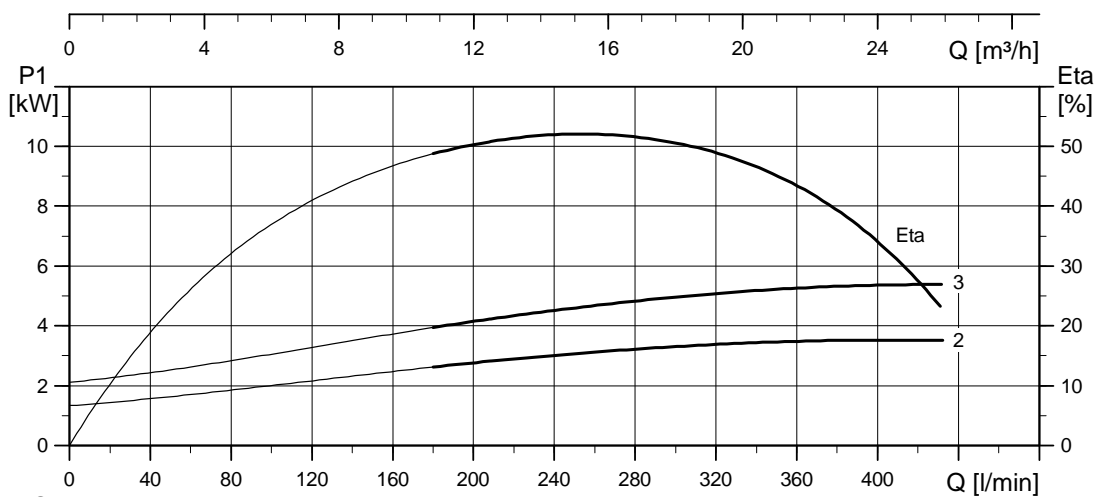
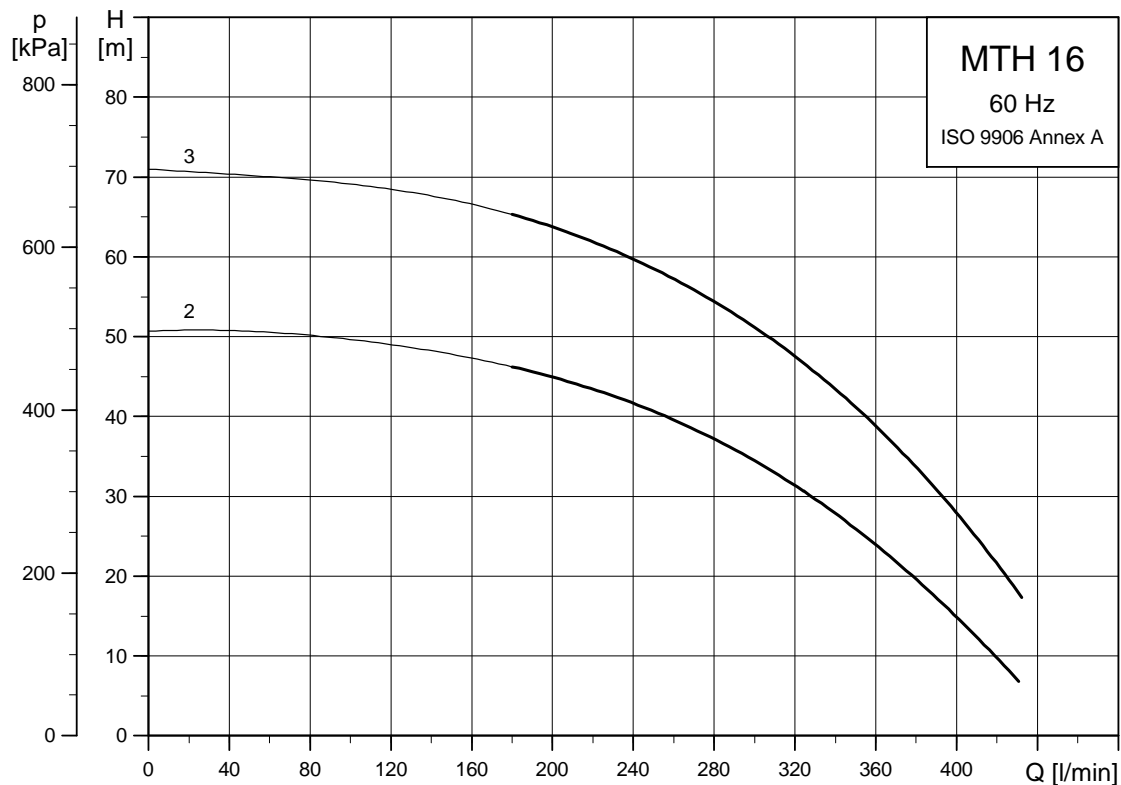

TM01.4501.3700

Dimensional sketches

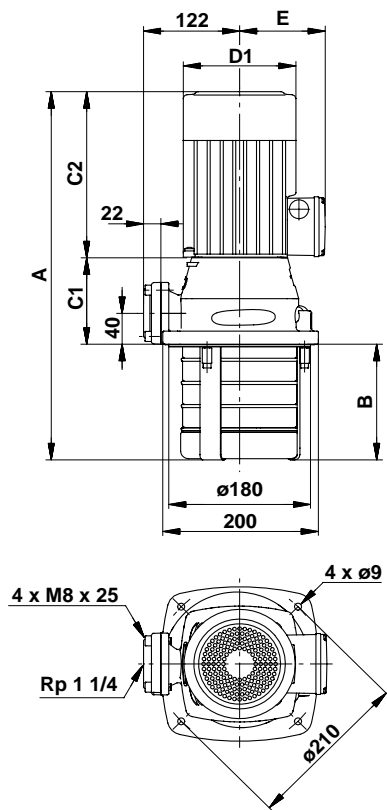

TM01 41991800

Dimensions and weights

Pump type	Dimensions [mm]						Weight [kg]
	A	B	C1	C2	D1	E	
MTH 16-20/2	510	75	141	294	178	110	45
MTH 16-30/3	602	120	141	341	220	134	62
MTH 16-40/3	647	165	141	341	220	134	63
MTH 16-50/3	692	210	141	341	220	134	64
MTH 16-60/3	737	255	141	341	220	134	65

Electrical data

3 x 208-230/460 V, 60 Hz

Pump type	Motor P_1 [W]	Full load current $I_{1/1}$ [A]	Power factor $\cos \pi_{1/1}$	Motor efficiency ξ [%]	$\frac{I_{start}}{I_{1/1}}$
MTH 16-20/2	3524	11.85-11.18/6.00	0.90-0.86	86.0-87.0	7.4-9.5
MTH 16-30/3	5377	18.34-17.63/9.00	0.92-0.88	87.5-89.5	8.2-10.7
MTH 16-40/3	5377	18.34-17.63/9.00	0.92-0.88	87.5-89.5	8.2-10.7
MTH 16-50/3	5377	18.34-17.63/9.00	0.92-0.88	87.5-89.5	8.2-10.7
MTH 16-60/3	5377	18.34-17.63/9.00	0.92-0.88	87.5-89.5	8.2-10.7

3 x 200-230/346-400 V, 60 Hz

Pump type	Motor P_1 [W]	Full load current $I_{1/1}$ [A]	Power factor $\cos \pi_{1/1}$	Motor efficiency ξ [%]	$\frac{I_{start}}{I_{1/1}}$
MTH 16-20/2	3524	10.81/6.24	0.90-0.86	86.0-87.0	7.4-9.5
MTH 16-30/3	5377	16.70/9.63	0.92-0.88	87.5-89.5	8.2-10.7

3 x 220-277/380-480 V, 60 Hz

Pump type	Motor P_1 [W]	Full load current $I_{1/1}$ [A]	Power factor $\cos \pi_{1/1}$	Motor efficiency ξ [%]	$\frac{I_{start}}{I_{1/1}}$
MTH 16-20/2	3524	9.83/5.70	0.90-0.83	86.0-87.0	7.4-11.0
MTH 16-30/3	5377	15.20/8.80	0.93-0.86	81.0-83.0	5.90-7.50

CRK, 50 Hz

Performance range

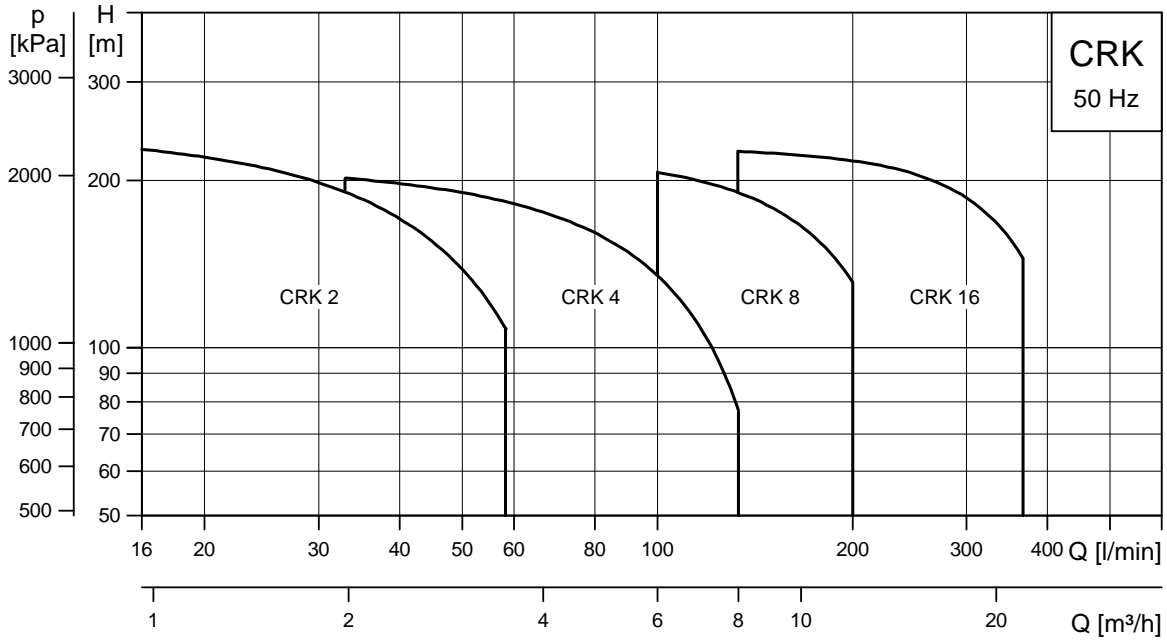

TM01.4463.0398

Product range

CRK 2

Example: CRK 2-60/6	Number of impellers												B [mm]		
	2	3	4	5	6	7	9	11	13	15	18	22		26	
20	-	-	-	-	-	-	-	-	-	-	-	-	-	-	160
30	-	-	-	-	-	-	-	-	-	-	-	-	-	-	178
40	-	-	-	-	-	-	-	-	-	-	-	-	-	-	196
50	-	-	-	-	-	-	-	-	-	-	-	-	-	-	214
60	-	-	-	-	-	-	-	-	-	-	-	-	-	-	232
70	-	-	-	-	-	-	-	-	-	-	-	-	-	-	250
90	-	-	-	-	-	-	-	-	-	-	-	-	-	-	286
110	-	-	-	-	-	-	-	-	-	-	-	-	-	-	322
130	-	-	-	-	-	-	-	-	-	-	-	-	-	-	358
150	-	-	-	-	-	-	-	-	-	-	-	-	-	-	394
180	-	-	-	-	-	-	-	-	-	-	-	-	-	-	448
220	-	-	-	-	-	-	-	-	-	-	-	-	-	-	520
260	-	-	-	-	-	-	-	-	-	-	-	-	-	-	592
500 ^a	-	-	-	-	-	-	-	-	-	-	-	-	-	-	1005
Motor [kW]	0.37	0.37	0.55	0.55	0.75	0.75	1.1	1.1	1.5	1.5	2.2	2.2	3.0		

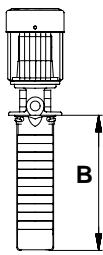

Number of chambers x 10

- available on request.#

^a with extension pipe.

CRK 4

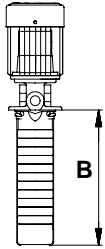
Example: CRK 4-60/6		Number of impellers												B		
		2	3	4	5	6	7	8	10	12	14	16	19	22	[mm]	
	Number of chambers x 10	20	·												169	
		30	·	·												196
		40	·	·	·											223
		50	·	·	·	·										250
		60	·	·	·	·	·									277
		70	·	·	·	·	·	·								304
		80	·	·	·	·	·	·	·							331
		100	·	·	·	·	·	·	·	·						385
		120	·	·	·	·	·	·	·	·	·					439
		140	·	·	·	·	·	·	·	·	·	·				493
		160	·	·	·	·	·	·	·	·	·	·	·			547
		190	·	·	·	·	·	·	·	·	·	·	·	·		628
		220	·	·	·	·	·	·	·	·	·	·	·	·	·	709
330 ^a	·	·	·	·	·	·	·	·	·	·	·	·	·	1005		
Motor [kW]		0.37	0.55	0.75	1.1	1.1	1.5	1.5	2.2	2.2	3.0	3.0	4.0	4.0		

[~] available on request. #

^a with extension pipe.

CRK 8

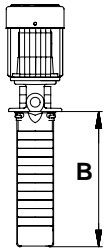
Example: CRK 8-60/6		Number of impellers												B		
		1	2	3	4	5	6	8	10	12	14	16	18	20	[mm]	
	Number of chambers x 10	20	·	·											148	
		30	·	·	·											178
		40	·	·	·	·										208
		50	·	·	·	·	·									238
		60	·	·	·	·	·	·								268
		80	·	·	·	·	·	·	·							328
		100	·	·	·	·	·	·	·	·						388
		120	·	·	·	·	·	·	·	·	·					448
		140	·	·	·	·	·	·	·	·	·	·				508
		160	·	·	·	·	·	·	·	·	·	·	·			568
		180	·	·	·	·	·	·	·	·	·	·	·	·		628
200	·	·	·	·	·	·	·	·	·	·	·	·	·	688		
Motor [kW]		0.75	0.75	1.1	1.5	2.2	2.2	3.0	4.0	4.0	5.5	5.5	7.5	7.5		

CRK 16

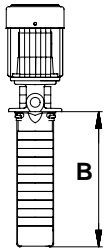
Example: CRK 16-60/6		Number of impellers										B			
		1	2	3	4	5	6	7	8	10	12	14	16	[mm]	
	Number of chambers x 10	20	·	·										178	
		30	·	·	·										223
		40	·	·	·	·									268
		50	·	·	·	·	·								313
		60	·	·	·	·	·	·							358
		70	·	·	·	·	·	·	·						403
		80	·	·	·	·	·	·	·	·					448
		100	·	·	·	·	·	·	·	·	·				538
		120	·	·	·	·	·	·	·	·	·	·			628
140	·	·	·	·	·	·	·	·	·	·	·		718		
160	·	·	·	·	·	·	·	·	·	·	·	·	808		
Motor [kW]		1.1	2.2	3.0	4.0	5.5	5.5	7.5	7.5	11	11	15	15		

CRK, 60 Hz

Performance range

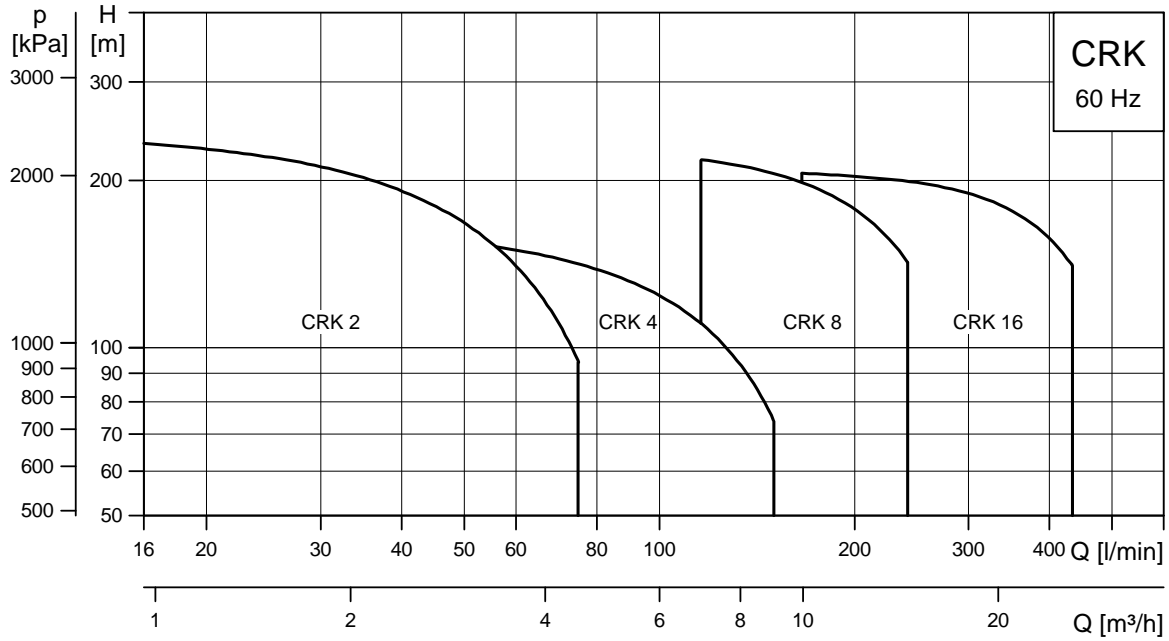

TM01 4464 0398

Product range

CRK 2

Example: CRK 2-60/6	Number of impellers											B [mm]
	2	3	4	5	6	7	9	11	13	15	18	
20	160
30	178
40	196
50	214
60	232
70	250
90	286
110	322
130	358
150	394
180	448
220	520
260	592
500 ^a	1005
Motor [kW]	0.37	0.55	0.75	1.1	1.1	1.5	2.2	2.2	3.0	3.0	4.0	

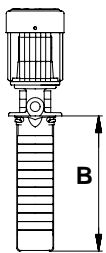

Number of chambers x 10

- available on request.#

^a with extension pipe.

CRK 4

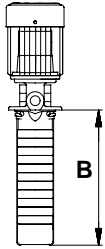
Example: CRK 4-60/6		Number of impellers										B
		2	3	4	5	6	7	8	10	12	[mm]	
	Number of chambers x 10	20	-	-	-	-	-	-	-	-	169	
		30	-	-	-	-	-	-	-	-	-	196
		40	-	-	-	-	-	-	-	-	-	223
		50	-	-	-	-	-	-	-	-	-	250
		60	-	-	-	-	-	-	-	-	-	277
		70	-	-	-	-	-	-	-	-	-	304
		80	-	-	-	-	-	-	-	-	-	331
		100	-	-	-	-	-	-	-	-	-	385
		120	-	-	-	-	-	-	-	-	-	439
		140	-	-	-	-	-	-	-	-	-	493
		160	-	-	-	-	-	-	-	-	-	547
		190	-	-	-	-	-	-	-	-	-	628
		220	-	-	-	-	-	-	-	-	-	709
		330 ^a	-	-	-	-	-	-	-	-	-	1005
Motor [kW]		0.75	1.1	1.5	2.2	2.2	3.0	3.0	4.0	4.0		

- available on request.#

^a with extension pipe.

CRK 8

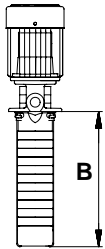
Example: CRK 8-60/6		Number of impellers										B
		2	3	4	5	6	8	10	12	14	[mm]	
	Number of chambers x 10	20	-	-	-	-	-	-	-	-	148	
		30	-	-	-	-	-	-	-	-	-	178
		40	-	-	-	-	-	-	-	-	-	208
		50	-	-	-	-	-	-	-	-	-	238
		60	-	-	-	-	-	-	-	-	-	268
		80	-	-	-	-	-	-	-	-	-	328
		100	-	-	-	-	-	-	-	-	-	388
		120	-	-	-	-	-	-	-	-	-	448
		140	-	-	-	-	-	-	-	-	-	508
		160	-	-	-	-	-	-	-	-	-	568
		180	-	-	-	-	-	-	-	-	-	628
200	-	-	-	-	-	-	-	-	-	688		
Motor [kW]		1.5	2.2	3.0	3.0	4.0	5.5	7.5	7.5	11		

CRK 16

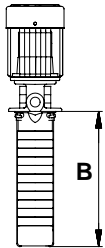
Example: CRK 16-60/6		Number of impellers										B
		1	2	3	4	5	6	7	8	10	[mm]	
	Number of chambers x 10	20	-	-	-	-	-	-	-	-	178	
		30	-	-	-	-	-	-	-	-	-	223
		40	-	-	-	-	-	-	-	-	-	268
		50	-	-	-	-	-	-	-	-	-	313
		60	-	-	-	-	-	-	-	-	-	358
		70	-	-	-	-	-	-	-	-	-	403
		80	-	-	-	-	-	-	-	-	-	448
		100	-	-	-	-	-	-	-	-	-	538
		120	-	-	-	-	-	-	-	-	-	628
		140	-	-	-	-	-	-	-	-	-	718
160	-	-	-	-	-	-	-	-	-	808		
Motor [kW]		1.5	3.0	5.5	7.5	7.5	11	11	15	15		

Product description

CRK is designed for pumping cooling lubricants for machine tools, condensate transfer and other purposes.

The pumps can be used for applications involving spark machine tools, grinding machines, machining centres, cooling units, industrial washing machines, filtering systems etc.

Pumped liquids

Thin, clean, non-explosive liquids without abrasive particles or fibres. Both water and water-soluble coolants and cutting lubricants can be pumped.

Pump

The pump is a multistage, centrifugal pump with mechanical shaft seal according to DIN 24960. Mounting flange sizes according to DIN 5440. To meet specific depths of tanks or containers, the installation length of the pump can be varied using empty chambers.

Example: A CRK 4 pump with 7 impellers is available with installation lengths from CRK 4-70 to CRK 4-220 (dimension B).

Note: Empty chambers may cause pressure loss.

I-version

As standard the CRK pumps are available as I-version called CRKI. All parts of CRKI pumps in contact with the pumped liquid are made of stainless steel (DIN W.-Nr 1.4401 or 1.4408, AISI 316 or 316LN).

Motor

The pump is fitted with a totally enclosed, fan-cooled standard motor with principal dimensions according to IEC, DIN and British standards.

Enclosure class :	IP 54#
Insulation class :	F#
Standard voltages, 50 Hz :	3 x 200 - 220/346-380 V# 3 x 200/346 V# 3 x 220 - 240/380 - 415 V# 3 x 380 - 415 V.
Standard voltages, 60 Hz :	3 x 200 - 230/346 - 400 V# 3 x 220 - 255/380 - 440 V# 3 x 220 - 277/380 - 480 V# 3 x 380 - 480 V.

Other voltages available on request.

CRK is also available with variable speed motors, type MGE:

MGE single phase:	0.25 - 1.1 kW#
MGE three phase:	0.75 - 7.5 kW.

Max. ambient temperature

Due to the low density and consequently low cooling effect of the air, operation at an ambient temperature above 40°C or at an altitude exceeding 1000 m above sea level requires a reduction of P2.

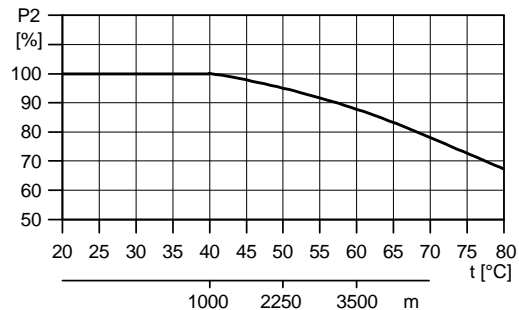

TM00 2189 4298

Example:#

From the above figure appears that P2 must be reduced to 88% when the pump is installed 3500 m above sea level. At an ambient temperature of 70°C, P2 must be reduced to 80% of rated output.

Sound pressure level

Motor [kW]	\bar{L}_{pA} [dB(A)]	
	50 Hz	60 Hz
0.37	<70	<70
0.55	<70	<70
0.75	<70	<70
1.1	<70	<70
1.5	<70	71
2.2	<70	71
3.0	<70	71
4.0	73	71
5.5	73	78
7.5	73	78
11	80	84
15	72	77

Shaft seal

Max. operating pressure and liquid temperature for the shaft seal

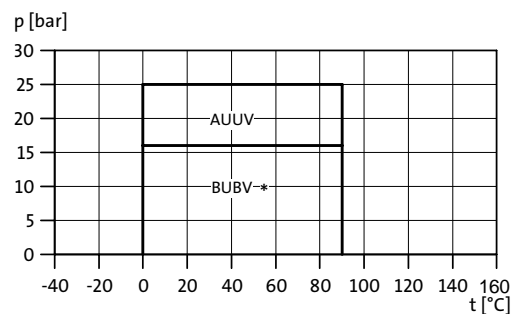

TM03 0024 3804

^a BUBV available on request.

Type key

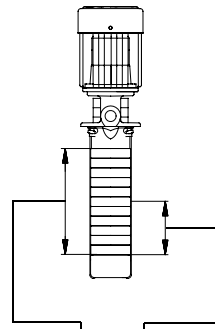

Example	CRK	4 - 140	/	8	A - W - A	AUUV
Pump type						
Nominal flow [m ³ /h]						
Number of chambers x 10						
Number of impellers# (ref. to performance curve and motor size)						
Pump version# A : Basic L : With extension pipe						
Connection code						
Materials# A : Basic I : I-version (stainless steel)						
Shaft seal						

Extension chambers

CRK 2 and CRK 4 pumps can be extended by means of empty chambers enabling installation lengths up to 1005 mm.

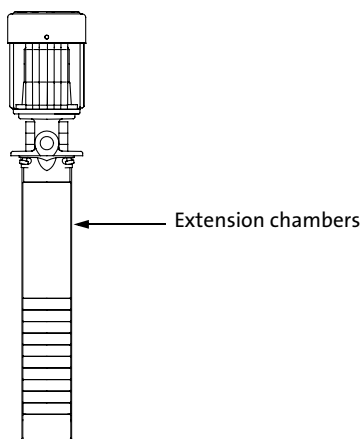

TM01 4214 1299

Installation

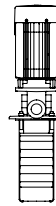

TM00 1924 3297

CRK 2 and 4

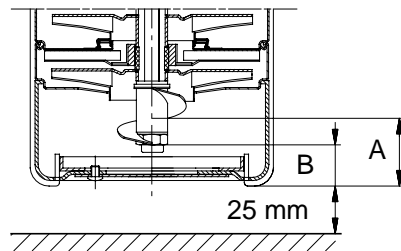

TM01 7810 3801

CRK 8 and 16

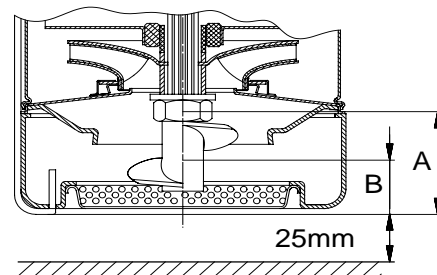

TM01 7811 4899

The pumps are designed to provide full performance down to a level of A mm above the bottom of the strainer.

At a liquid level between A and B mm above the bottom of the strainer, the built-in priming screw will protect the pump against dry running.

Pump type	A [mm]	B [mm]
CRK 2 and 4	41	28
CRK 8 and 16	50	25

Materials

Pos.	Description	Materials	DIN W.-Nr.	AISI/ASTM
1	Flange ^a	Cast iron # EN-GJL-200	0.6020	ASTM 25B
2	Motor stool	Cast iron # EN-GJL-200	0.6020	ASTM 25B
		Stainless steel# (I-version)	1.4408	AISI 316LN
2k	Adapter flange	Cast iron # EN-GJL-200	0.6020	ASTM 25B
3	Top Intermediate chamber # (not CRK 2)	Stainless steel	1.4301	AISI 304
4	Intermediate chamber	Stainless steel	1.4301	AISI 304
4a	Intermediate chamber with bearing	Stainless steel	1.4301	AISI 304
5a	Bottom intermediate chamber	Stainless steel	1.4301	AISI 304
7	Coupling guard	Stainless steel	1.4301	AISI 304
8	Coupling	Cast iron EN-GJS-400-15	0.7040	ASTM 60-40-18
9	Allen screw	Stainless steel		
10	Shaft pin	Stainless steel	1.4301	AISI 304
10a	Coupling half	Cast iron # EN-GJS-400-15	0.7040	ASTM 60-40-18
26	Strap	Stainless steel	1.4301	AISI 304
28	Set screw	Stainless steel		
28a	Set screw	Stainless steel		
36	Nut	Stainless steel		
36a	Nut	Stainless steel		
37	Gasket	Paper		
37a	Gasket	Paper		
44	Suction chamber	Stainless steel	1.4301	AISI 304
45	Neck ring	PTFE		
47a	Bearing ring	Tungsten# carbide		
49	Impeller	Stainless steel	1.4301	AISI 304
49d	Impeller	Stainless steel	1.4301	AISI 304
51	Spline shaft	Stainless steel	1.4057	AISI 431
61	Spacing pipe	Stainless steel	1.4401	AISI 316
62	Stop ring	Stainless steel	1.4436	AISI 316
64	Spacing pipe	Stainless steel	1.4301	AISI 304
64a	Spacing pipe	Stainless steel	1.4301	AISI 304
64b	Spacing pipe	Stainless steel	1.4301	AISI 304
64c	Spacing pipe	Stainless steel	1.4301	AISI 304
65	Retainer for neck ring	Stainless steel	1.4301	AISI 304
66	Washer	Stainless steel		
66a	Washer	Stainless steel		
67	Lock nut	Stainless steel		
69	Spacing pipe	Stainless steel	1.4301	AISI 304
69a	Spacing pipe	Stainless steel	1.4301	AISI 304
84	Strainer:# CRK 2, # ø2 mm holes CRK 4, 8 and 16, # ø4 mm holes	Stainless steel	1.4301	AISI 304
84a	Retainer for strainer	Stainless steel	1.4301	AISI 304
84b	Screw steel			
102	O-ring	FKM		
103	Upper seal ring			
104	Lower seal ring			
105	Shaft seal			

Pos.	Description	Materials	DIN W.-Nr.	AISI/ASTM
107	O-ring	FKM		
108	Spring			
111	Upper drive			
112	Lower drive			
121	Pull ring			
122	Priming screw	Stainless steel		

^a Rectangular flange available on request.

Sectional drawing CRK 2, CRK 4

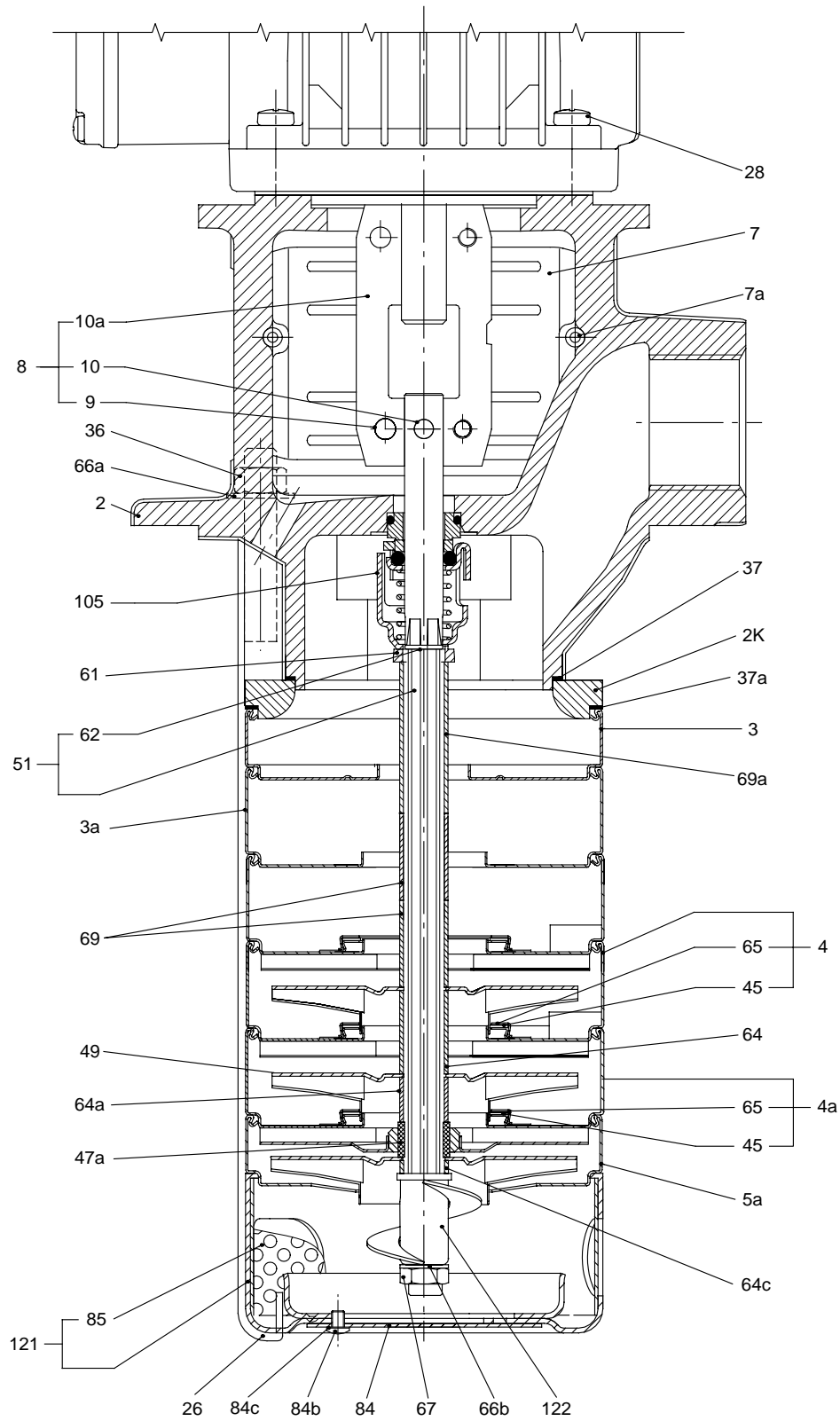

TM01 9399 1901

Sectional drawing CRK 8, CRK 16

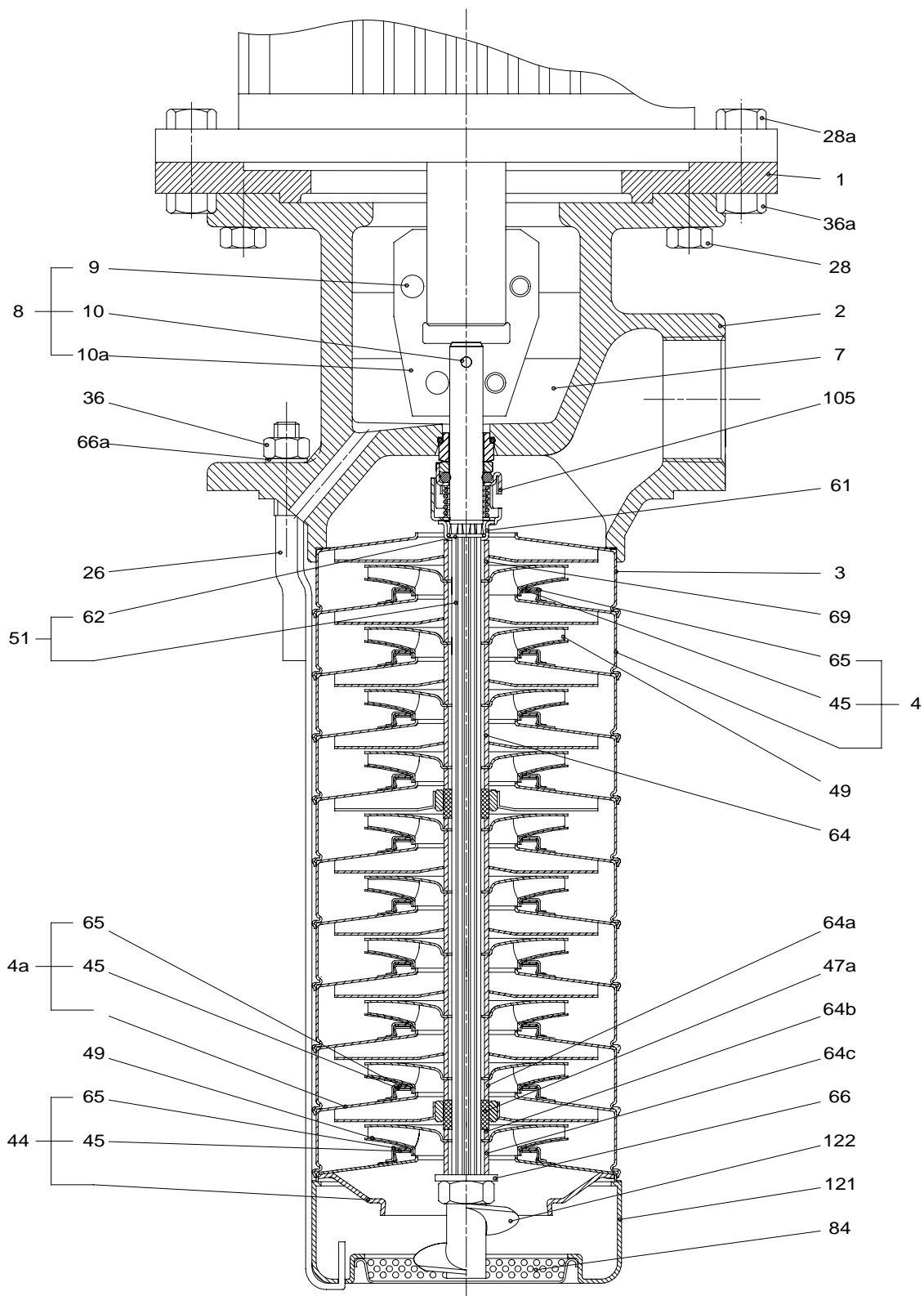

TM00 4255 0499

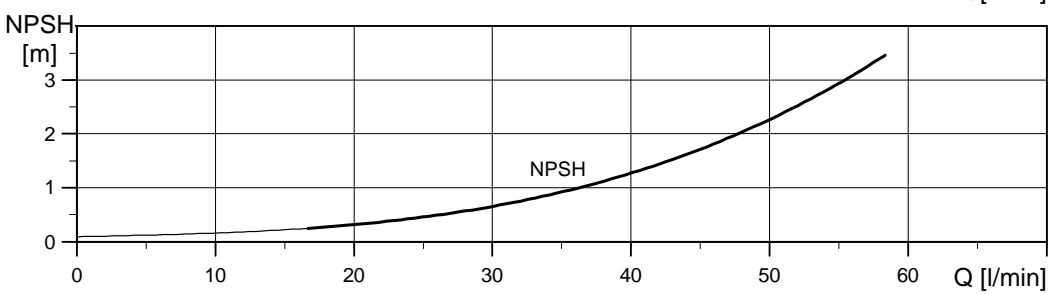
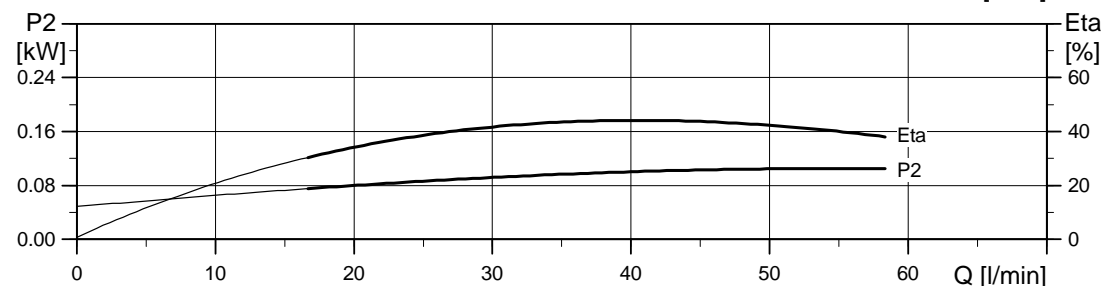
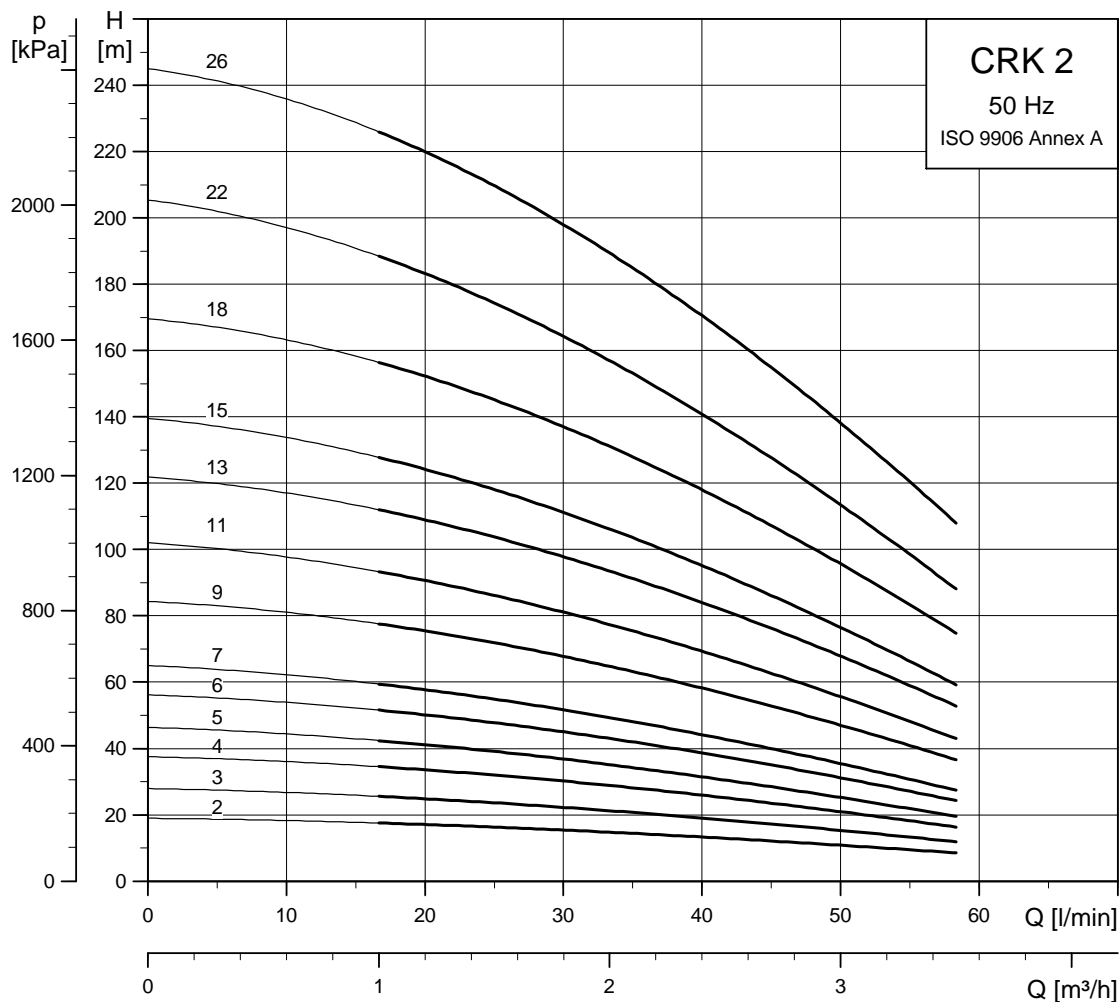

TM00 1942 3700

Dimensional sketches

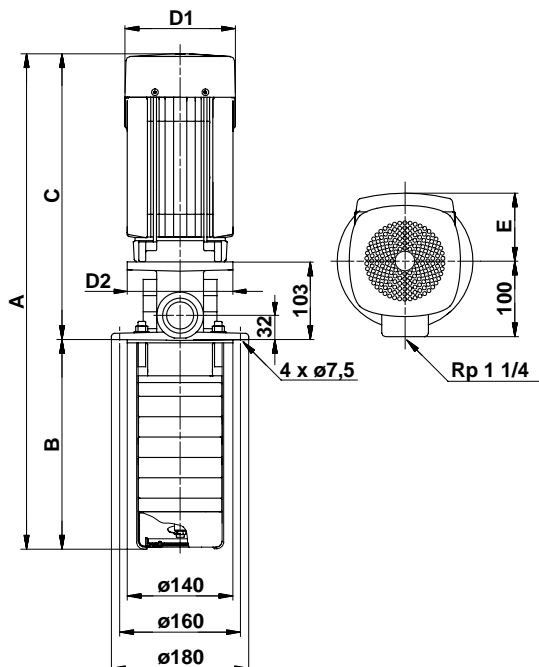

Dimensions and weights

Pump type	Dimensions [mm]						Weight [kg] ^a
	A	B	C	D1	D2	E	
CRK 2-20/2	454	160	294	142	140	109	12.2
CRK 2-30/3	472	178	294	142	140	109	12.5
CRK 2-40/4	490	196	294	142	140	109	13.3
CRK 2-50/5	508	214	294	142	140	109	13.6
CRK 2-60/6	566	232	334	142	140	109	14.7
CRK 2-70/7	584	250	334	142	140	109	15.0
CRK 2-90/9	620	286	334	142	140	109	17.0
CRK 2-110/11	656	322	334	142	140	109	17.6
CRK 2-130/13	742	358	384	178	140	110	25.9
CRK 2-150/15	778	394	384	178	140	110	26.5
CRK 2-180/18	832	448	384	178	140	110	29.4
CRK 2-220/22	904	520	384	178	140	110	30.6
CRK 2-260/26	1030	592	438	178	160	110	37.0
CRK 2-500/26	1443	1005	438	178	160	110	43.3

^a The stated weights apply to CRK only. For CRKI, add 1 kg.

Electrical data

3 x 220-240/380-415 V, 50 Hz

Pump type	Motor		Full load current $I_{1/1}$ [A]	Power factor $\cos \pi_{1/1}$	Motor efficiency ξ [%]	$\frac{I_{start}}{I_{1/1}}$
	Type	P_2 [kW]				
CRK 2-20/2	MG 71A	0.37	1.66/0.96	0.84-0.76	72	4.8-5.2
CRK 2-30/3	MG 71A	0.37	1.66/0.96	0.84-0.76	72	4.8-5.2
CRK 2-40/4	MG 71B	0.55	2.50/1.44	0.84-0.76	72	4.8-5.2
CRK 2-50/5	MG 71B	0.55	2.50/1.44	0.84-0.76	72	4.8-5.2
CRK 2-60/6	MG 80A	0.75	3.20/1.86	0.86-0.78	74	5.0-5.5
CRK 2-70/7	MG 80A	0.75	3.20/1.86	0.86-0.78	74	5.0-5.5
CRK 2-90/9	MG 80B	1.10	4.60/2.65	0.87-0.79	76	5.2-5.7
CRK 2-110/11	MG 80B	1.10	4.60/2.65	0.87-0.79	76	5.2-5.7
CRK 2-130/13	MG 90SA	1.50	5.90/3.40	0.85-0.79	82	6.3-6.9
CRK 2-150/15	MG 90SA	1.50	5.90/3.40	0.85-0.79	82	6.3-6.9
CRK 2-180/18	MG 90LA	2.20	8.25/4.75	0.87-0.82	84	7.0-7.6
CRK 2-220/22	MG 90LA	2.20	8.25/4.75	0.87-0.82	84	7.0-7.6
CRK 2-260/26	MG 100LB	3.00	10.8/6.25	0.88-0.82	86	7.8-8.5
CRK 2-500/26	MG 100LB	3.00	10.8/6.25	0.88-0.82	86	7.8-8.5

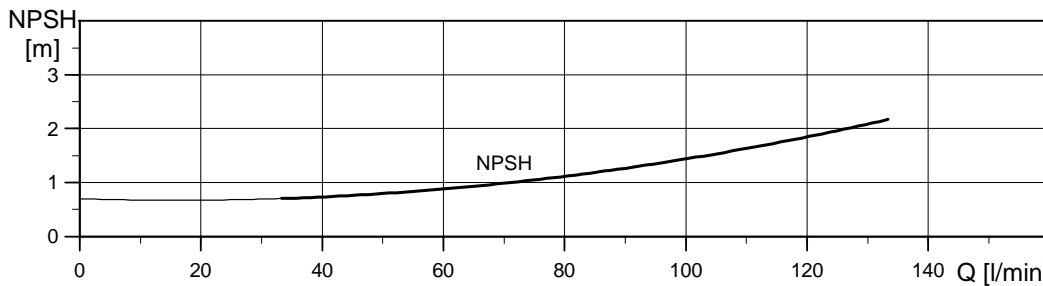
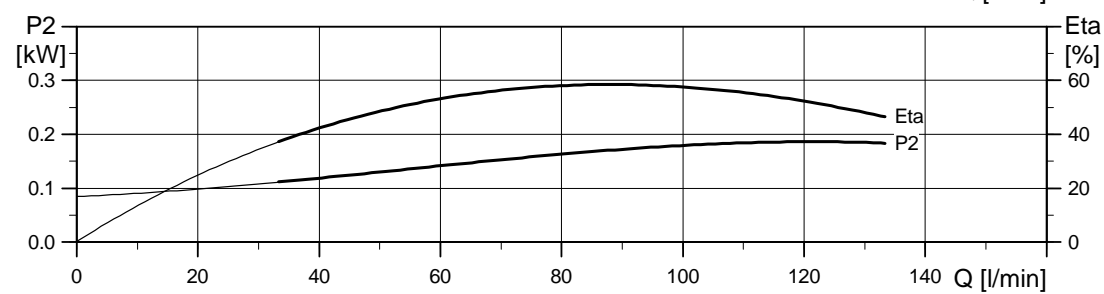
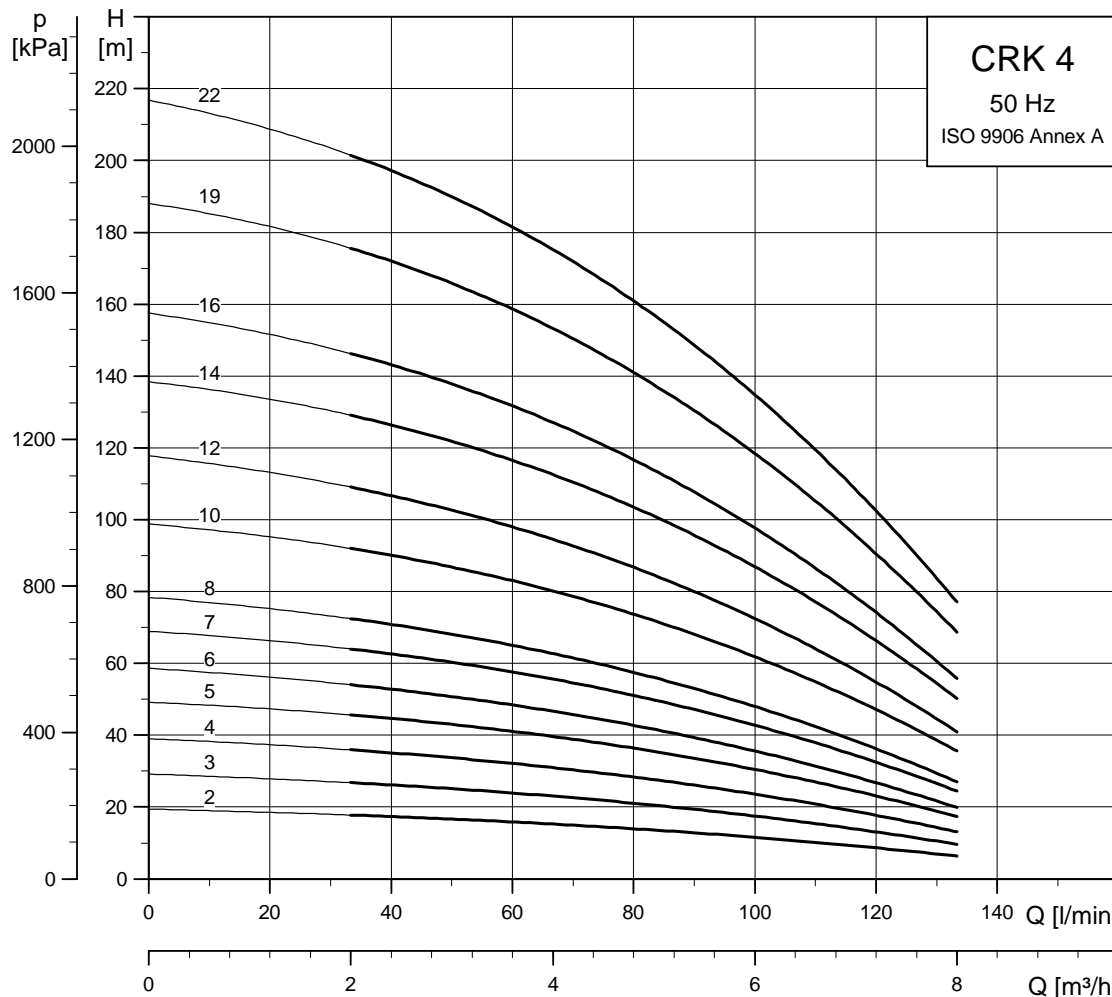

TM00 1944 3700

Dimensional sketches

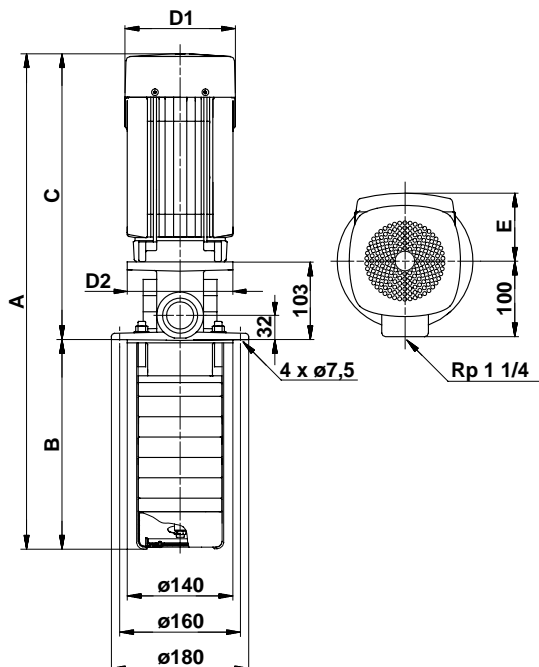

Dimensions and weights

Pump type	Dimensions [mm]						Weight [kg] ^a
	A	B	C	D1	D2	E	
CRK 4-20/2	463	169	294	142	140	109	12.1
CRK 4-30/3	490	196	294	142	140	109	13.0
CRK 4-40/4	557	223	334	142	140	109	14.3
CRK 4-50/5	584	250	334	142	140	109	16.1
CRK 4-60/6	611	277	334	142	140	109	16.5
CRK 4-70/7	688	304	384	178	140	110	25.8
CRK 4-80/8	715	331	384	178	140	110	26.2
CRK 4-100/10	769	385	384	178	140	110	29.5
CRK 4-120/12	823	439	384	178	140	110	30.3
CRK 4-140/14	931	493	438	178	160	110	34.9
CRK 4-160/16	985	547	438	178	160	110	35.7
CRK 4-190/19	1103	628	475	220	160	134	39.1
CRK 4-220/22	1184	709	475	220	160	134	40.4
CRK 4-330/22	1487	1005	475	220	160	134	43.8

^a The stated weights apply to CRK only. For CRKI, add 1.3 kg.

Electrical data

3 x 220-240/380-415 V, 50 Hz

Pump type	Motor		Full load current I _{1/1} [A]	Power factor Cos $\pi_{1/1}$	Motor efficiency ξ [%]	I _{start} / I _{1/1}
	Type	P ₂ [kW]				
CRK 4-20/2	MG 71A	0.37	1.66/0.96	0.84-0.76	72	4.8-5.2
CRK 4-30/3	MG 71B	0.55	2.50/1.44	0.84-0.76	72	4.8-5.2
CRK 4-40/4	MG 80A	0.75	3.20/1.86	0.86-0.78	74	5.0-5.5
CRK 4-50/5	MG 80B	1.10	4.60/2.65	0.87-0.79	76	5.2-5.7
CRK 4-60/6	MG 80B	1.10	4.60/2.65	0.87-0.79	76	5.2-5.7
CRK 4-70/7	MG 90SA	1.50	5.90/3.40	0.85-0.79	82	6.3-6.9
CRK 4-80/8	MG 90SA	1.50	5.90/3.40	0.85-0.79	82	6.3-6.9
CRK 4-100/10	MG 90LA	2.20	8.25/4.75	0.87-0.82	84	7.0-7.6
CRK 4-120/12	MG 90LA	2.20	8.25/4.75	0.87-0.82	84	7.0-7.6
CRK 4-140/14	MG 100LB	3.00	10.8/6.25	0.88-0.82	86	7.8-8.5
CRK 4-160/16	MG 100LB	3.00	10.8/6.25	0.88-0.82	86	7.8-8.5
CRK 4-190/19	MG 112MB	4.00	13.8/8.00	0.90-0.87	87	8.7-9.5
CRK 4-220/22	MG 112MB	4.00	13.8/8.00	0.90-0.87	87	8.7-9.5
CRK 4-330/22	MG 112MB	4.00	13.8/8.00	0.90-0.87	87	8.7-9.5

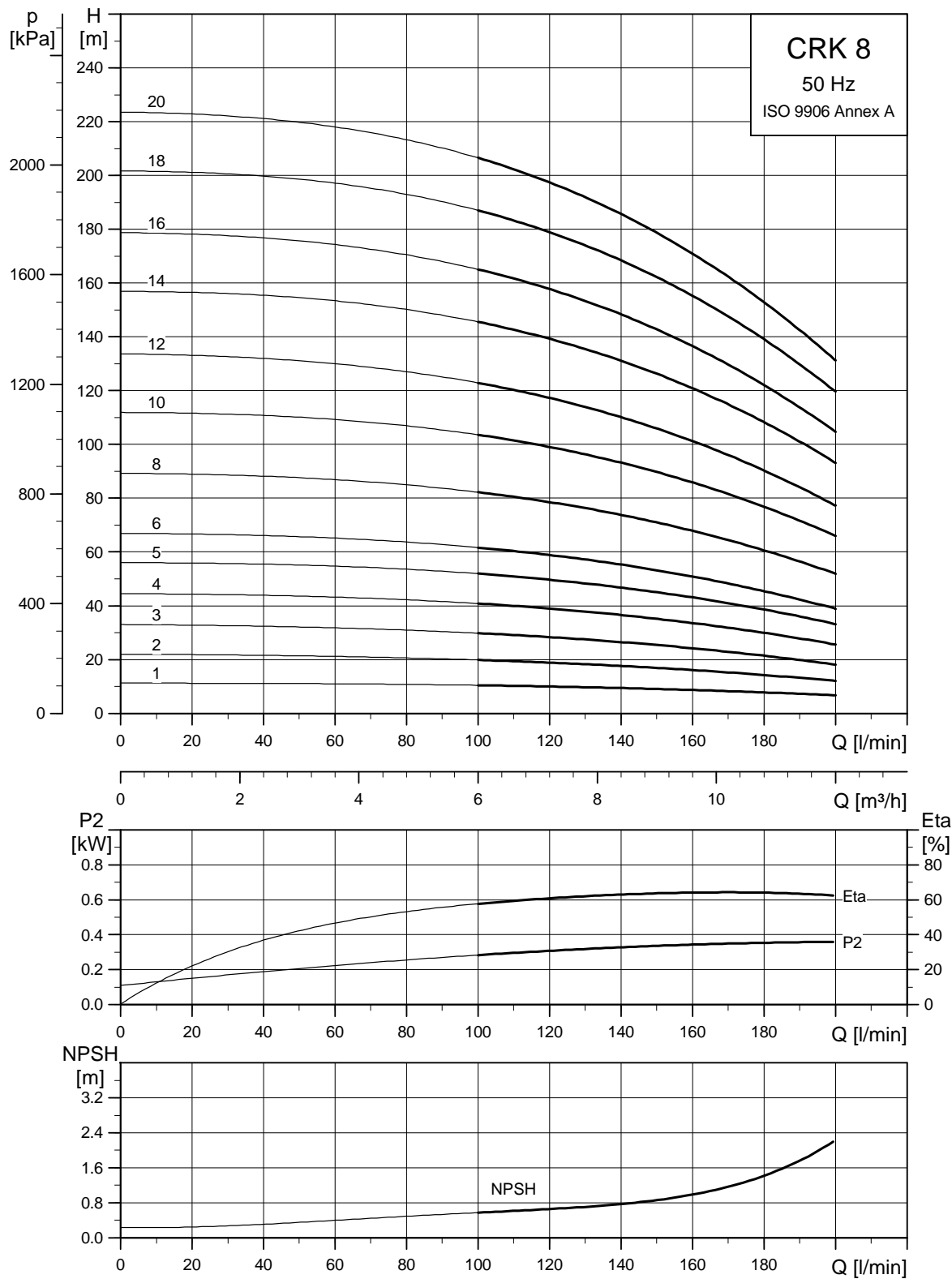

TM00 1946 3700

Dimensional sketches

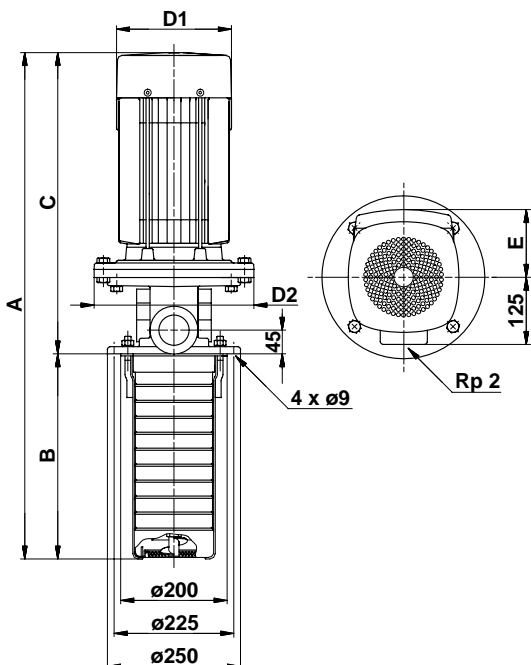

TM00 1921 3297

Dimensions and weights

Pump type	Dimensions [mm]						Weight [kg] ^a
	A	B	C	D1	D2	E	
CRK 8-20/1	523	148	375	142	140	109	22
CRK 8-20/2	523	148	375	142	140	109	22
CRK 8-30/3	553	178	375	142	140	109	24
CRK 8-40/4	628	208	420	178	140	110	31
CRK 8-50/5	658	238	420	178	140	110	35
CRK 8-60/6	688	268	420	178	140	110	36
CRK 8-80/8	803	328	475	178	160	110	40
CRK 8-100/10	900	388	512	220	160	134	43
CRK 8-120/12	960	448	512	220	160	134	44
CRK 8-140/14	1043	508	535	220	300	134	68
CRK 8-160/16	1103	568	535	220	300	134	69
CRK 8-180/18	1163	628	535	220	300	134	75
CRK 8-200/20	1223	688	535	220	300	134	76

^a The stated weights apply to CRK only. For CRKI, add 1.3 kg.

Electrical data

3 x 220-240/380-415 V, 50 Hz

Pump type	Motor		Full load current I _{1/1} [A]	Power factor Cos $\pi_{1/1}$	Motor efficiency ξ [%]	I _{start} / I _{1/1}
	Type	P ₂ [kW]				
CRK 8-20/1	MG 80A	0.75	3.20/1.86	0.86-0.78	74	5.0-5.5
CRK 8-20/2	MG 80A	0.75	3.20/1.86	0.86-0.78	74	5.0-5.5
CRK 8-30/3	MG 80B	1.10	4.60/2.65	0.87-0.79	76	5.2-5.7
CRK 8-40/4	MG 90SA	1.50	5.90/3.40	0.85-0.79	82	6.3-6.9
CRK 8-50/5	MG 90LA	2.20	8.25/4.75	0.87-0.82	84	7.0-7.6
CRK 8-60/6	MG 90LA	2.20	8.25/4.75	0.87-0.82	84	7.0-7.6
CRK 8-80/8	MG 100LB	3.00	10.8/6.25	0.88-0.82	86	7.8-8.5
CRK 8-100/10	MG 112MB	4.00	13.8/8.00	0.90-0.87	87	8.7-9.5
CRK 8-120/12	MG 112MB	4.00	13.8/8.00	0.90-0.87	87	8.7-9.5
CRK 8-140/14	MG 132SB	5.50	19.0/11.0	0.89-0.86	88.5	8.9-9.7
CRK 8-160/16	MG 132SB	5.50	19.0/11.0	0.89-0.86	88.5	8.9-9.7
CRK 8-180/18	MG 132SC	7.50	26.5/15.2	0.87-0.81	89	9.1-9.9
CRK 8-200/20	MG 132SC	7.50	26.5/15.2	0.87-0.81	89	9.1-9.9

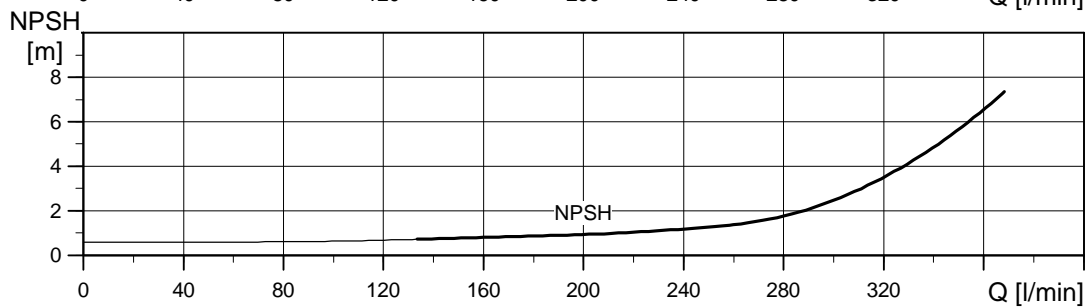
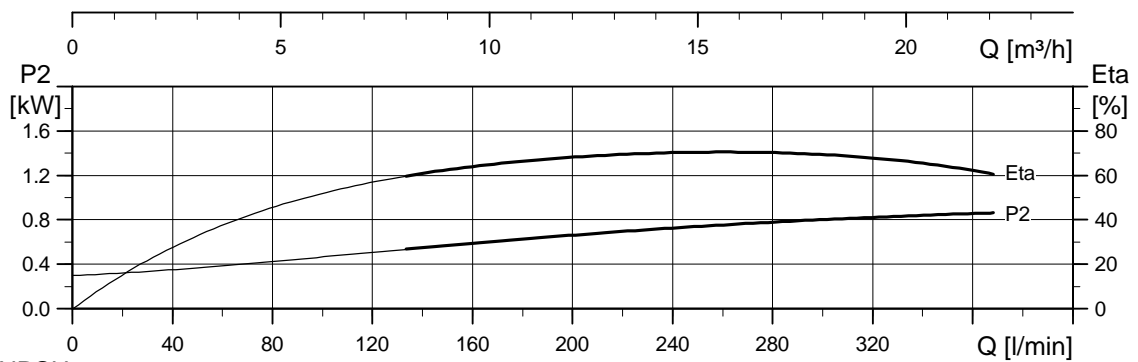
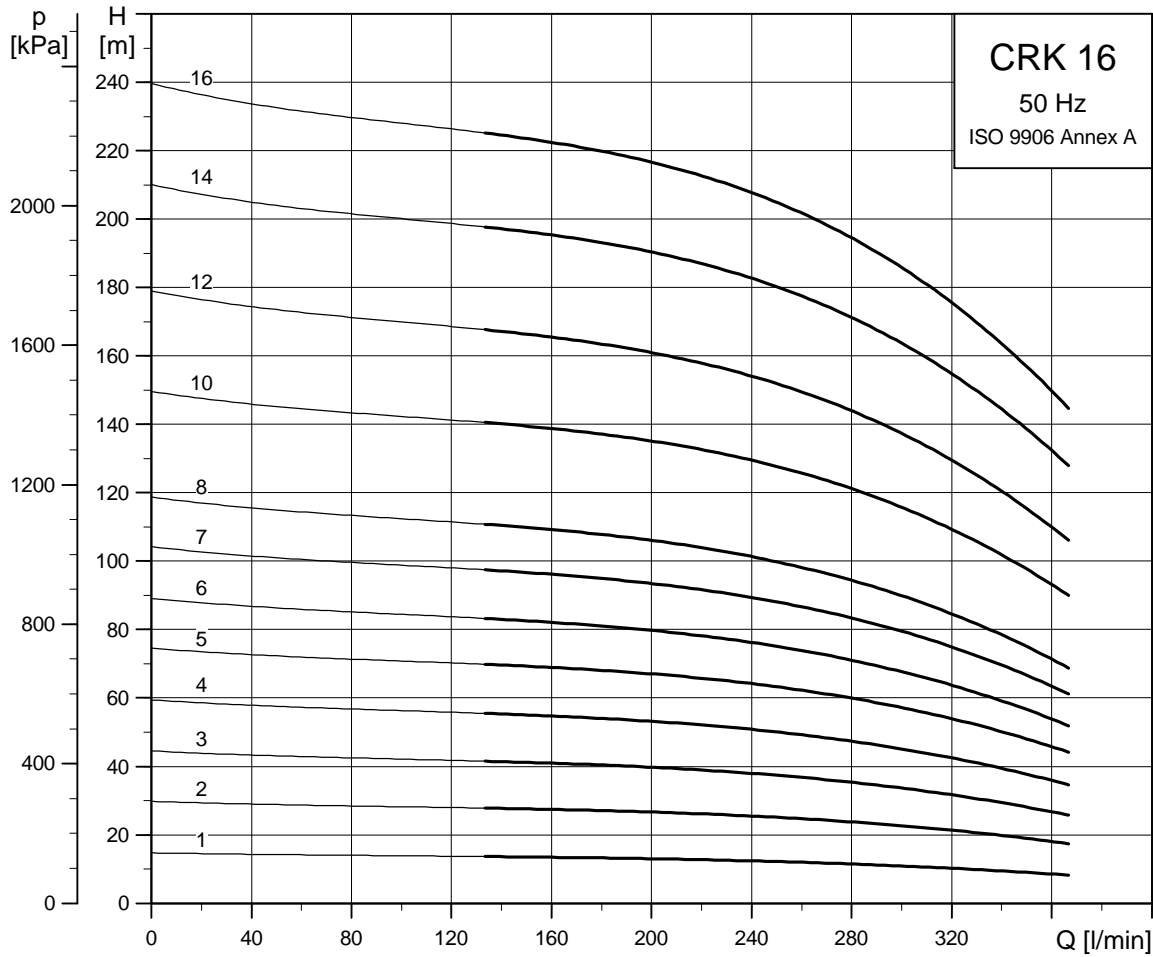

TM00 19-48 3700

Dimensional sketches

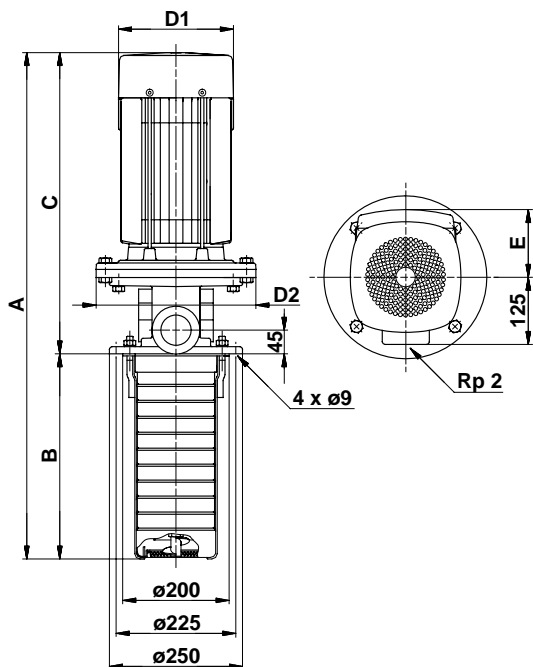

TM00 1921 3297

Dimensions and weights

Pump type	Dimensions [mm]						Weight [kg] ^a
	A	B	C	D1	D2	E	
CRK 16-20/1	533	178	375	142	142	109	31
CRK 16-20/2	698	178	420	178	140	110	34
CRK 16-30/3	689	223	475	178	160	110	38
CRK 16-40/4	780	268	515	220	160	134	40
CRK 16-50/5	848	313	535	220	300	134	63
CRK 16-60/6	893	358	535	220	300	134	64
CRK 16-70/7	938	403	535	220	300	134	70
CRK 16-80/8	983	448	535	220	300	134	71
CRK 16-100/10	1198	538	660	260	350	172	101
CRK 16-120/12	1288	628	660	260	350	172	103
CRK 16-140/14	1423	718	705	306	350	197	149
CRK 16-160/16	1513	808	705	306	350	197	155

^a The stated weights apply to CRK only. For CRKI, add 1.3 kg.

Electrical data

3 x 220-240/380-415 V, 50 Hz

Pump type	Motor		Full load current $I_{1/1}$ [A]	Power factor $\cos \pi_{1/1}$	Motor efficiency ξ [%]	$\frac{I_{start}}{I_{1/1}}$
	Type	P_2 [kW]				
CRK 16-20/1	MG 80B	1.10	4.60/2.65	0.87-0.79	76	5.2-5.7
CRK 16-20/2	MG 90LA	2.20	8.25/4.75	0.87-0.82	84	7.0-7.6
CRK 16-30/3	MG 100LB	3.00	10.8/6.25	0.88-0.82	86	7.8-8.5
CRK 16-40/4	MG 112MB	4.00	13.8/8.00	0.90-0.87	87	8.7-9.5
CRK 16-50/5	MG 132SB	5.50	19.0/11.0	0.89-0.86	88.5	8.9-9.7
CRK 16-60/6	MG 132SB	5.50	19.0/11.0	0.89-0.86	88.5	8.9-9.7
CRK 16-70/7	MG 132SC	7.50	26.5/15.2	0.87-0.81	89	9.1-9.9
CRK 16-80/8	MG 132SC	7.50	26.5/15.2	0.87-0.81	89	9.1-9.9
CRK 16-100/10	MG 160MB	11.0	37.0/21.4	0.89-0.87	90	7.3-8.1
CRK 16-120/12	MG 160MB	11.0	37.0/21.4	0.89-0.87	90	7.3-8.1
CRK 16-140/14	160M	15.0	49.7/28.7	0.87	86	6.0
CRK 16-160/16	160M	15.0	49.7/28.7	0.87	86	6.0

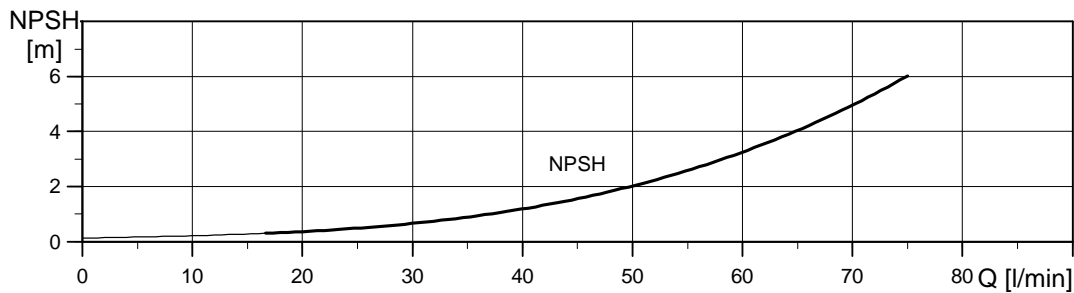
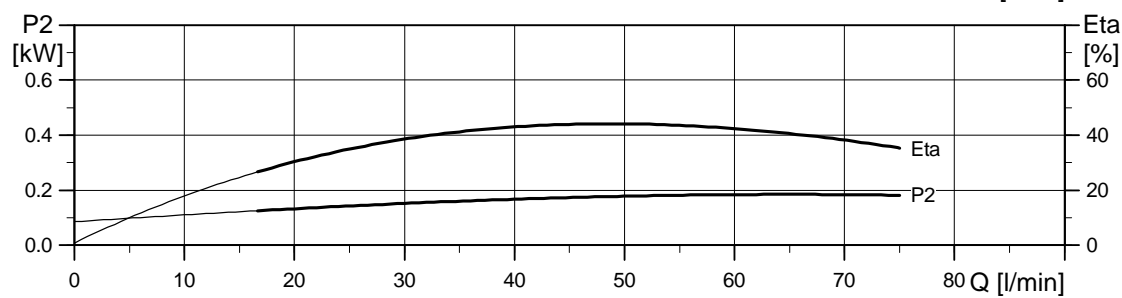
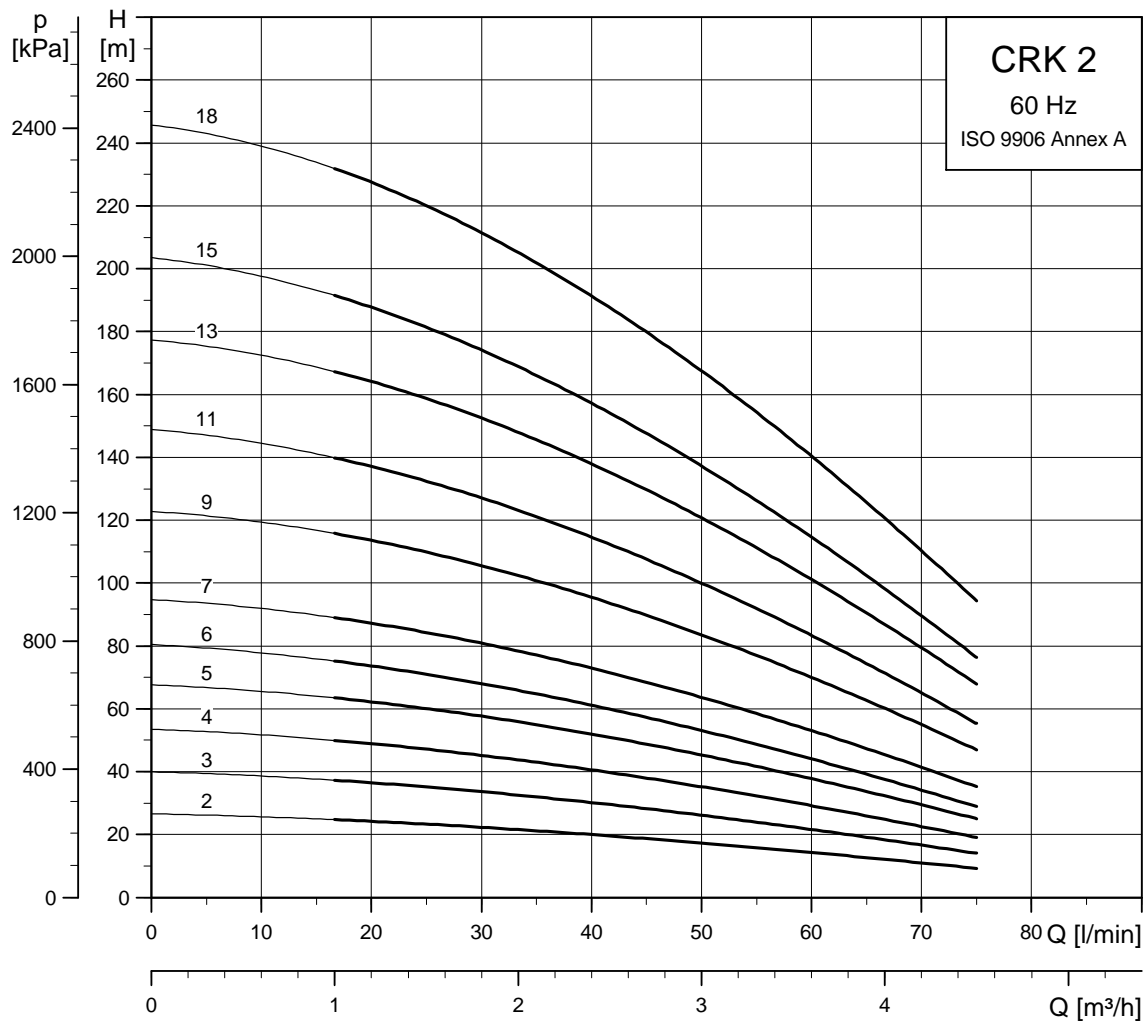

TM00 1943 3700

Dimensional sketches

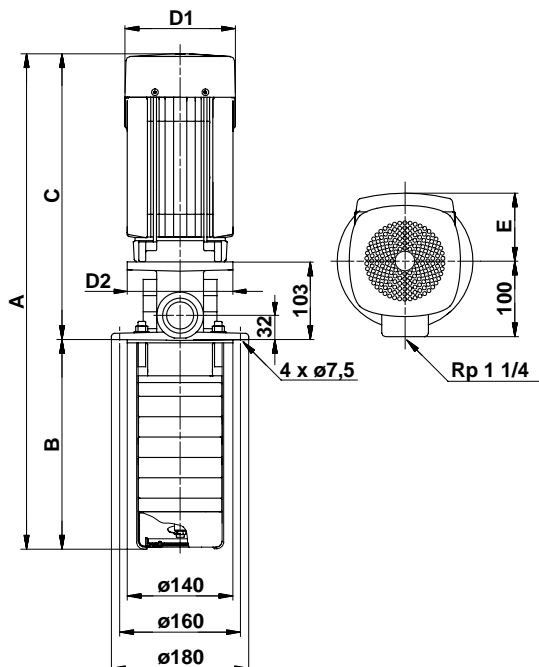

Dimensions and weights

Pump type	Dimensions [mm]						Weight [kg] ^a
	A	B	C	D1	D2	E	
CRK 2-20/2	454	160	294	142	140	109	12.3
CRK 2-30/3	472	178	294	142	140	109	13.0
CRK 2-40/4	530	196	334	142	140	109	14.1
CRK 2-50/5	548	214	334	142	140	109	15.8
CRK 2-60/6	566	232	334	142	140	109	16.1
CRK 2-70/7	634	250	384	178	140	110	24.1
CRK 2-90/9	670	286	384	178	140	110	28.4
CRK 2-110/11	706	322	384	178	140	110	29.0
CRK 2-130/13	796	358	438	178	160	110	33.4
CRK 2-150/15	832	394	438	178	160	110	34.0
CRK 2-180/18	923	448	475	220	160	134	36.1
CRK 2-220/18	995	520	475	220	160	134	36.5
CRK 2-260/18	1067	592	475	220	160	134	36.9
CRK 2-500/18	1480	1005	475	220	160	134	43.2

^a The stated weights apply to CRK only. For CRK1, add 1 kg.

Electrical data

3 x 220-255/380-440 V, 60 Hz

Pump type	Motor		Full load current I _{1/1} [A]	Power factor Cos π _{1/1}	Motor efficiency ξ [%]	I _{start} / I _{1/1}
	Type	P ₂ [kW]				
CRK 2-20/2	MG 71A	0.37	1.58-1.46/0.91-0.84	0.88-0.82	72.0-73.0	4.80-6.00
CRK 2-30/3	MG 71B	0.55	2.40-2.18/1.38-1.26	0.88-0.82	71.0-72.0	4.80-6.00
CRK 2-40/4	MG 80A	0.75	3.15-2.85/1.82-1.64	0.89-0.84	73.0-74.0	5.10-6.50
CRK 2-50/5	MG 80B	1.10	4.50-4.00/2.60-2.32	0.89-0.84	76.0-77.0	5.10-6.50
CRK 2-60/6	MG 80B	1.10	4.50-4.00/2.60-2.32	0.89-0.84	76.0-77.0	5.10-6.50

Electrical data

3 x 220-277/380-480 V, 60 Hz

CRK 2-70/7	MG 90SA	1.50	5.70-5.00/3.30-2.90	0.89-0.78	80.5-82.0	5.90-8.40
CRK 2-90/9	MG 90LA	2.20	8.05-6.95/4.65-4.00	0.90-0.81	83.0-84.5	6.50-9.50
CRK 2-110/11	MG 90LA	2.20	8.05-6.95/4.65-4.00	0.90-0.81	83.0-84.5	6.50-9.50
CRK 2-130/13	MG 100LB	3.00	10.6-9.00/6.10-5.20	0.90-0.83	86.0-87.0	7.40-11.0
CRK 2-150/15	MG 100LB	3.00	10.6-9.00/6.10-5.20	0.90-0.83	86.0-87.0	7.40-11.0
CRK 2-180/18	MG 112MB	4.00	13.6-11.4/7.85-6.60	0.92-0.85	87.0-88.0	8.00-12.0
CRK 2-220/18	MG 112MB	4.00	13.6-11.4/7.85-6.60	0.92-0.85	87.0-88.0	8.00-12.0
CRK 2-260/18	MG 112MB	4.00	13.6-11.4/7.85-6.60	0.92-0.85	87.0-88.0	8.00-12.0
CRK 2-500/18	MG 112MB	4.00	13.6-11.4/7.85-6.60	0.92-0.85	87.0-88.0	8.00-12.0

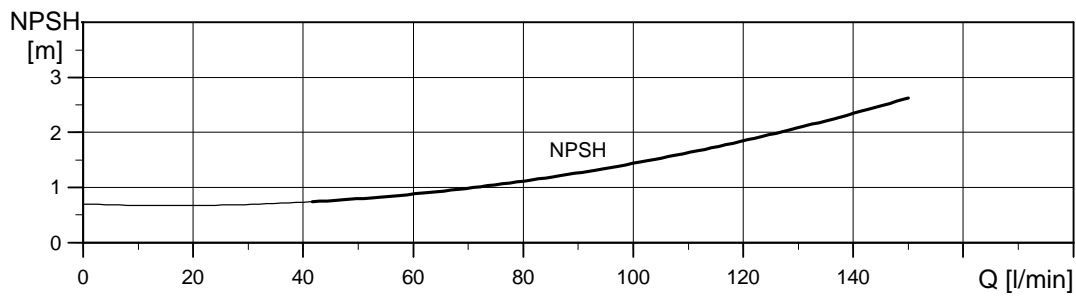
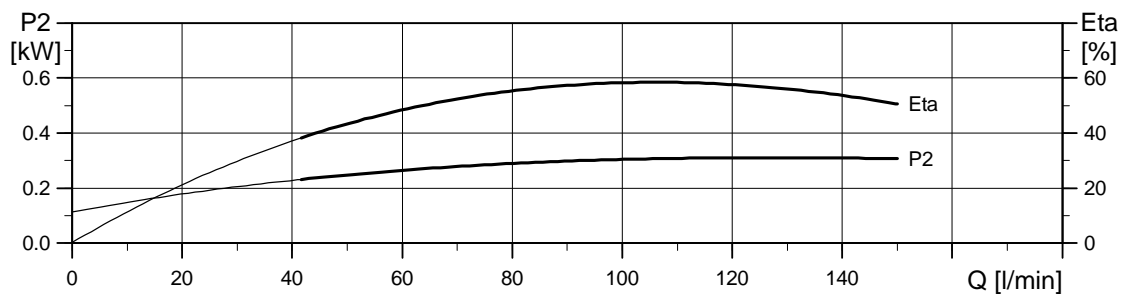
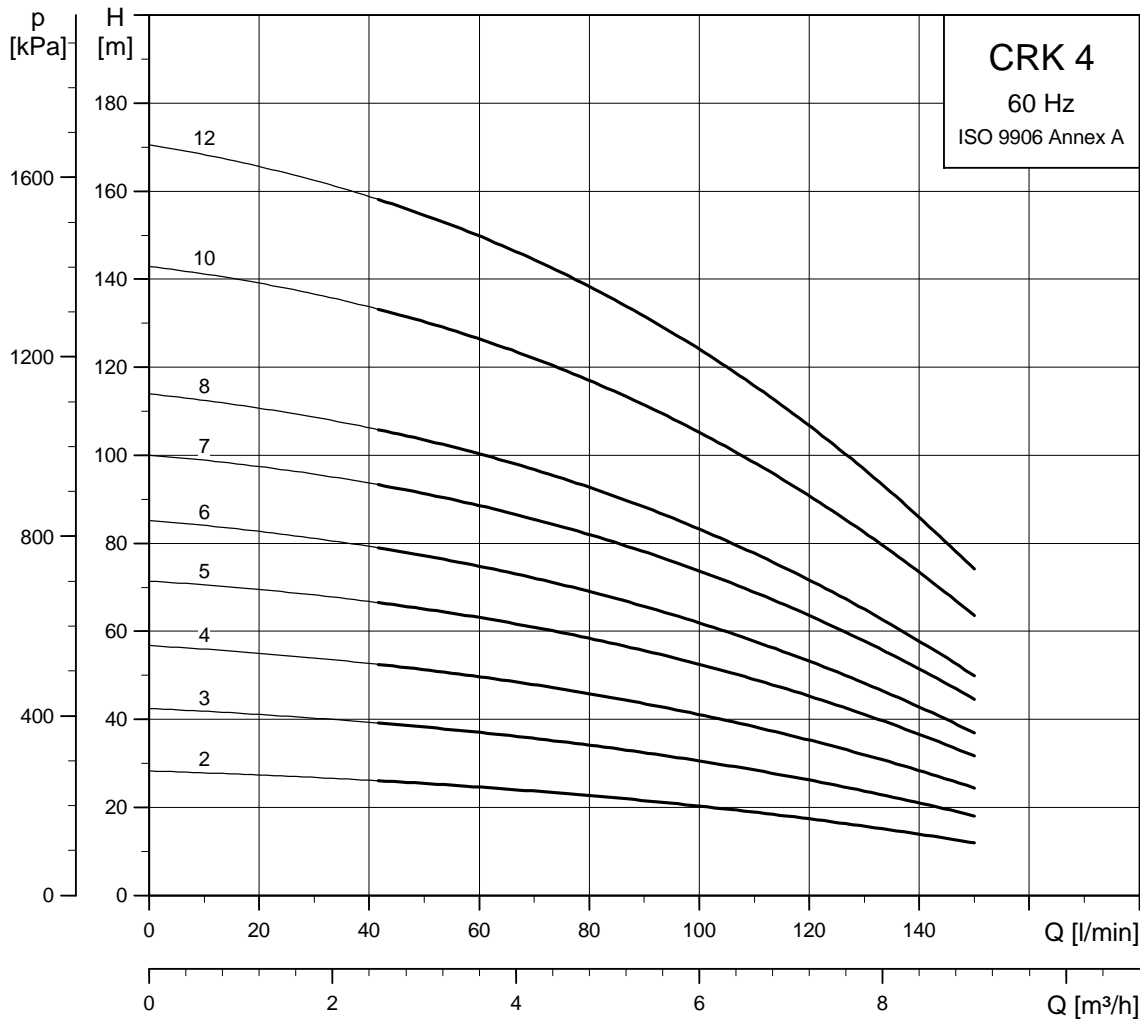

TM00 1945 3700

Dimensional sketches

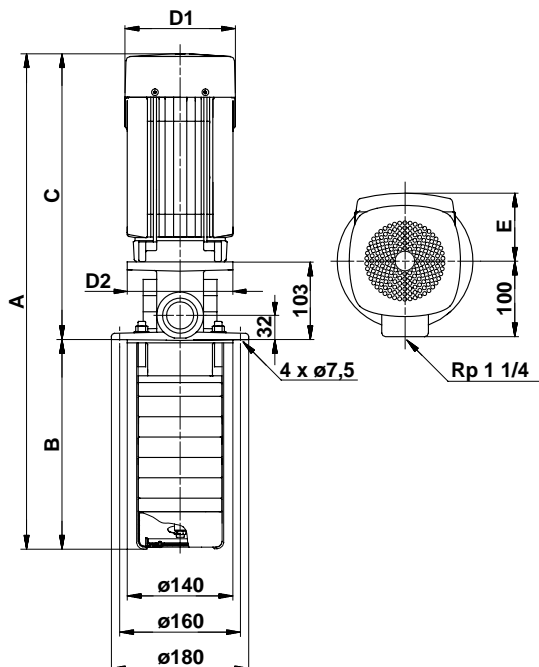

Dimensions and weights

Pump type	Dimensions [mm]						Weight [kg]*
	A	B	C	D1	D2	E	
CRK 4-20/2	503	169	334	142	140	109	13.5
CRK 4-30/3	530	196	334	142	140	109	15.3
CRK 4-40/4	607	223	384	178	140	110	24.6
CRK 4-50/5	634	250	384	178	140	110	27.5
CRK 4-60/6	661	277	384	178	140	110	27.9
CRK 4-70/7	742	304	438	178	160	110	32.1
CRK 4-80/8	769	331	438	178	160	110	32.5
CRK 4-100/10	860	385	475	220	160	134	36.8
CRK 4-120/12	914	439	475	220	160	134	37.6
CRK 4-140/12	968	493	475	220	160	134	37.8
CRK 4-160/12	1022	547	475	220	160	134	38.1
CRK 4-190/12	1103	628	475	220	160	134	38.4
CRK 4-220/12	1184	709	475	220	160	134	38.8
CRK 4-330/12	1487	1005	475	220	160	134	42.2

* The stated weights apply to CRK only. For CRK1, add 1.3 kg.

Electrical data

3 x 220-255/380-440 V, 60 Hz

Pump type	Motor		Full load current $I_{1/1}$ [A]	Power factor $\cos \pi_{1/1}$	Motor efficiency ξ [%]	$\frac{I_{start}}{I_{1/1}}$
	Type	P_2 [kW]				
CRK 4-20/2	MG 80A	0.75	3.15-2.85/1.82-1.64	0.89-0.84	73.0-74.0	5.10-6.50
CRK 4-30/3	MG 80B	1.10	4.50-4.00/2.60-2.32	0.89-0.84	76.0-77.0	5.10-6.50

Electrical data

3 x 220-277/380-480 V, 60 Hz

CRK 4-40/4	MG 90SA	1.50	5.70-5.00/3.30-2.90	0.89-0.78	80.5-82.0	5.90-8.40
CRK 4-50/5	MG 90LA	2.20	8.05-6.95/4.65-4.00	0.90-0.81	83.0-84.5	6.50-9.50
CRK 4-60/6	MG 90LA	2.20	8.05-6.95/4.65-4.00	0.90-0.81	83.0-84.5	6.50-9.50
CRK 4-70/7	MG 100LB	3.00	10.6-9.00/6.10-5.20	0.90-0.83	86.0-87.0	7.40-11.0
CRK 4-80/8	MG 100LB	3.00	10.6-9.00/6.10-5.20	0.90-0.83	86.0-87.0	7.40-11.0
CRK 4-100/10	MG 112MB	4.00	13.6-11.4/7.85-6.60	0.92-0.85	87.0-88.0	8.00-12.0
CRK 4-120/12	MG 112MB	4.00	13.6-11.4/7.85-6.60	0.92-0.85	87.0-88.0	8.00-12.0
CRK 4-140/12	MG 112MB	4.00	13.6-11.4/7.85-6.60	0.92-0.85	87.0-88.0	8.00-12.0
CRK 4-160/12	MG 112MB	4.00	13.6-11.4/7.85-6.60	0.92-0.85	87.0-88.0	8.00-12.0
CRK 4-190/12	MG 112MB	4.00	13.6-11.4/7.85-6.60	0.92-0.85	87.0-88.0	8.00-12.0
CRK 4-220/12	MG 112MB	4.00	13.6-11.4/7.85-6.60	0.92-0.85	87.0-88.0	8.00-12.0
CRK 4-330/12	MG 112MB	4.00	13.6-11.4/7.85-6.60	0.92-0.85	87.0-88.0	8.00-12.0

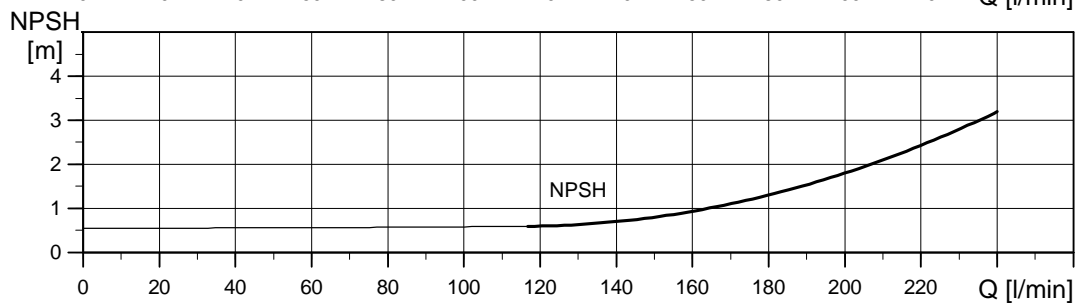
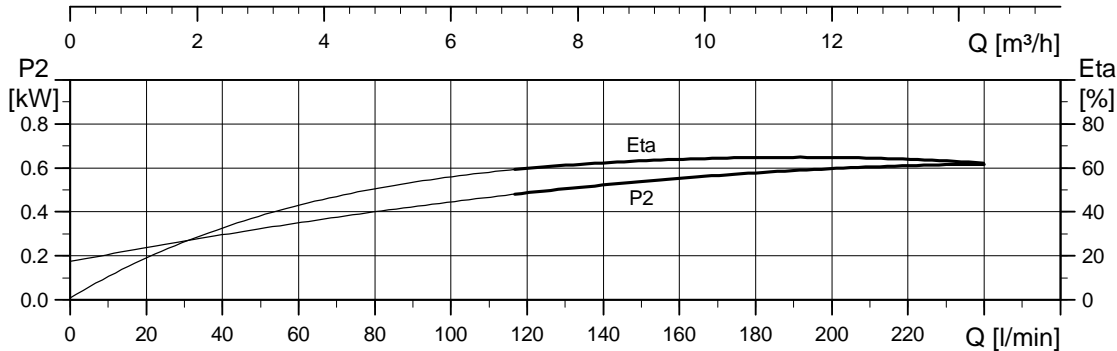
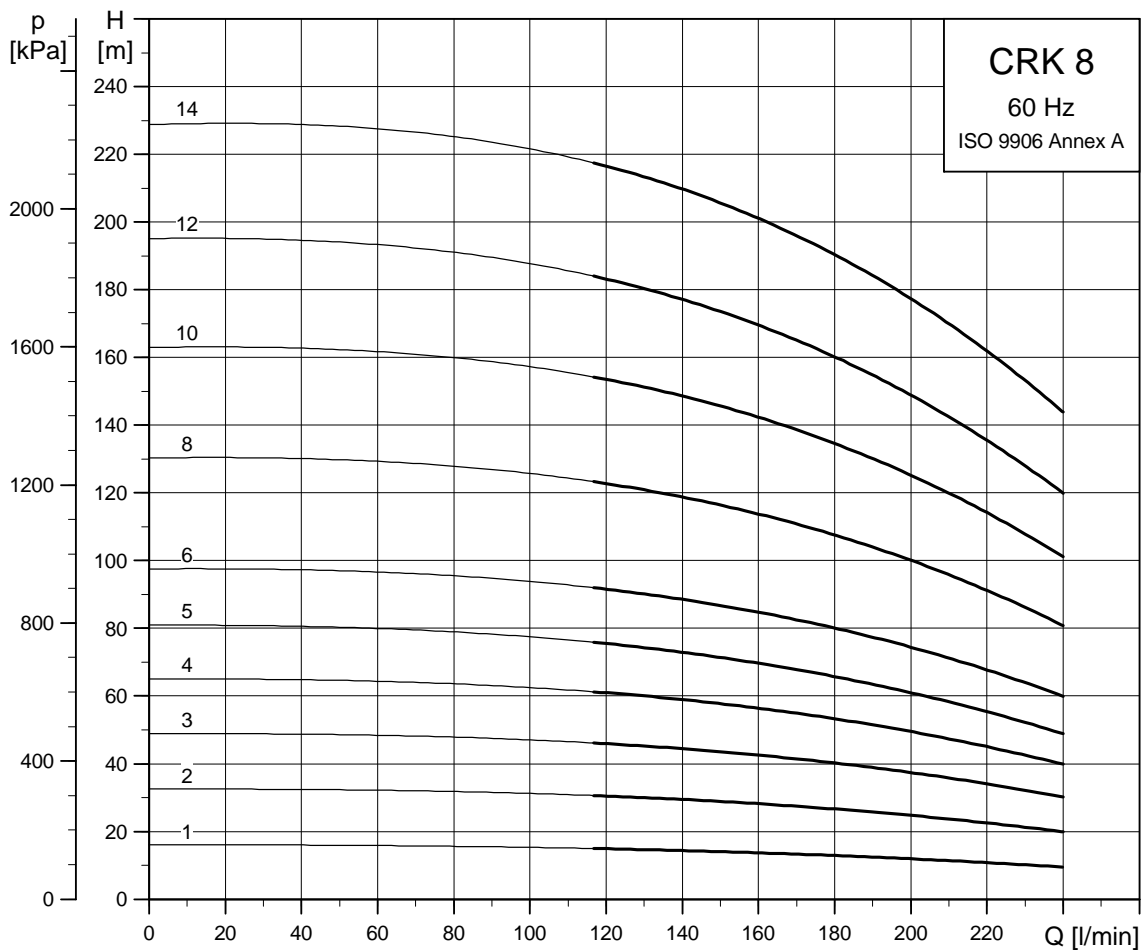

TM001947 3700

Dimensional sketches

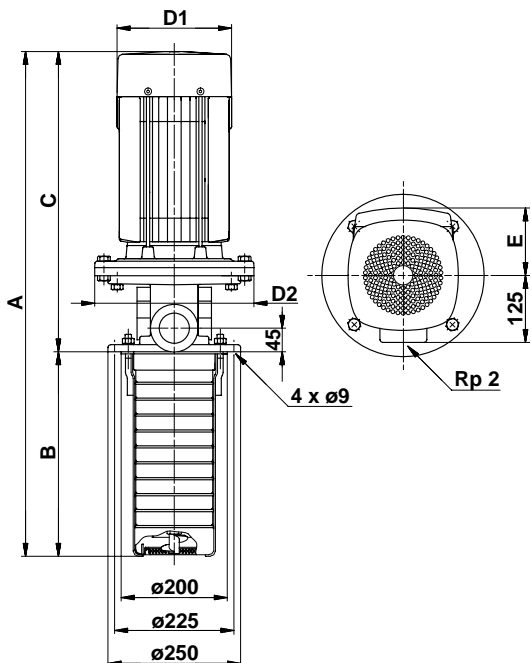

TM00 1921 3297

Dimensions and weights

Pump type	Dimensions [mm]						Weight [kg] ^a
	A	B	C	D1	D2	E	
CRK 8-20/1	523	148	375	142	140	109	28
CRK 8-20/2	568	148	420	178	140	110	31
CRK 8-30/3	598	178	420	178	140	110	34
CRK 8-40/4	683	208	475	178	160	110	38
CRK 8-50/5	713	238	475	178	160	110	39
CRK 8-60/6	780	268	512	220	160	134	40
CRK 8-80/8	863	328	535	220	300	134	64
CRK 8-100/10	923	388	535	220	300	134	70
CRK 8-120/12	983	448	535	220	300	134	71
CRK 8-140/14	1168	508	660	260	350	172	101
CRK 8-160/14	1228	568	660	260	350	172	102
CRK 8-180/14	1288	628	660	260	350	172	103
CRK 8-200/14	1348	688	660	260	350	172	104

^a The stated weights apply to CRK only. For CRK1, add 1.3 kg.

Electrical data

3 x 220-277/380-480 V, 60 Hz

Pump type	Motor		Full load current I _{1/1} [A]	Power factor Cos π _{1/1}	Motor efficiency ξ [%]	I _{start} I _{1/1}
	Type	P ₂ [kW]				
CRK 8-20/1	MG 80A	0.75	3.15-2.85/1.82-1.64	0.89-0.84	73.0-74.0	5.10-6.50

Electrical data

3 x 220-255/380-440 V, 60 Hz

CRK 8-20/2	MG 90SA	1.50	5.70-5.00/3.30-2.90	0.89-0.78	80.5-82.0	5.90-8.40
CRK 8-30/3	MG 90LA	2.20	8.05-6.95/4.65-4.00	0.90-0.81	83.0-84.5	6.50-9.50
CRK 8-40/4	MG 100LB	3.00	10.6-9.00/6.10-5.20	0.90-0.83	86.0-87.0	7.40-11.0
CRK 8-50/5	MG 100LB	3.00	10.6-9.00/6.10-5.20	0.90-0.83	86.0-87.0	7.40-11.0
CRK 8-60/6	MG 112MB	4.00	13.6-11.4/7.85-6.60	0.92-0.85	87.0-88.0	8.00-12.0
CRK 8-80/8	MG 132SB	5.50	18.8-15.6/10.8-9.00	0.92-0.85	87.5-89.5	8.20-12.4
CRK 8-100/10	MG 132SC	7.50	25.5-22.6/14.6-13.0	0.92-0.80	88.5-90.0	9.50-11.6
CRK 8-120/12	MG 132SC	7.50	25.5-22.6/14.6-13.0	0.92-0.80	88.5-90.0	9.50-11.6
CRK 8-140/14	MG 160MB	11.0	37.0-30.2/21.4-17.4	0.90-0.86	89.0-91.0	6.6-9.6
CRK 8-160/14	MG 160MB	11.0	37.0-30.2/21.4-17.4	0.90-0.86	89.0-91.0	6.6-9.6
CRK 8-180/14	MG 160MB	11.0	37.0-30.2/21.4-17.4	0.90-0.86	89.0-91.0	6.6-9.6
CRK 8-200/14	MG 160MB	11.0	37.0-30.2/21.4-17.4	0.90-0.86	89.0-91.0	6.6-9.6

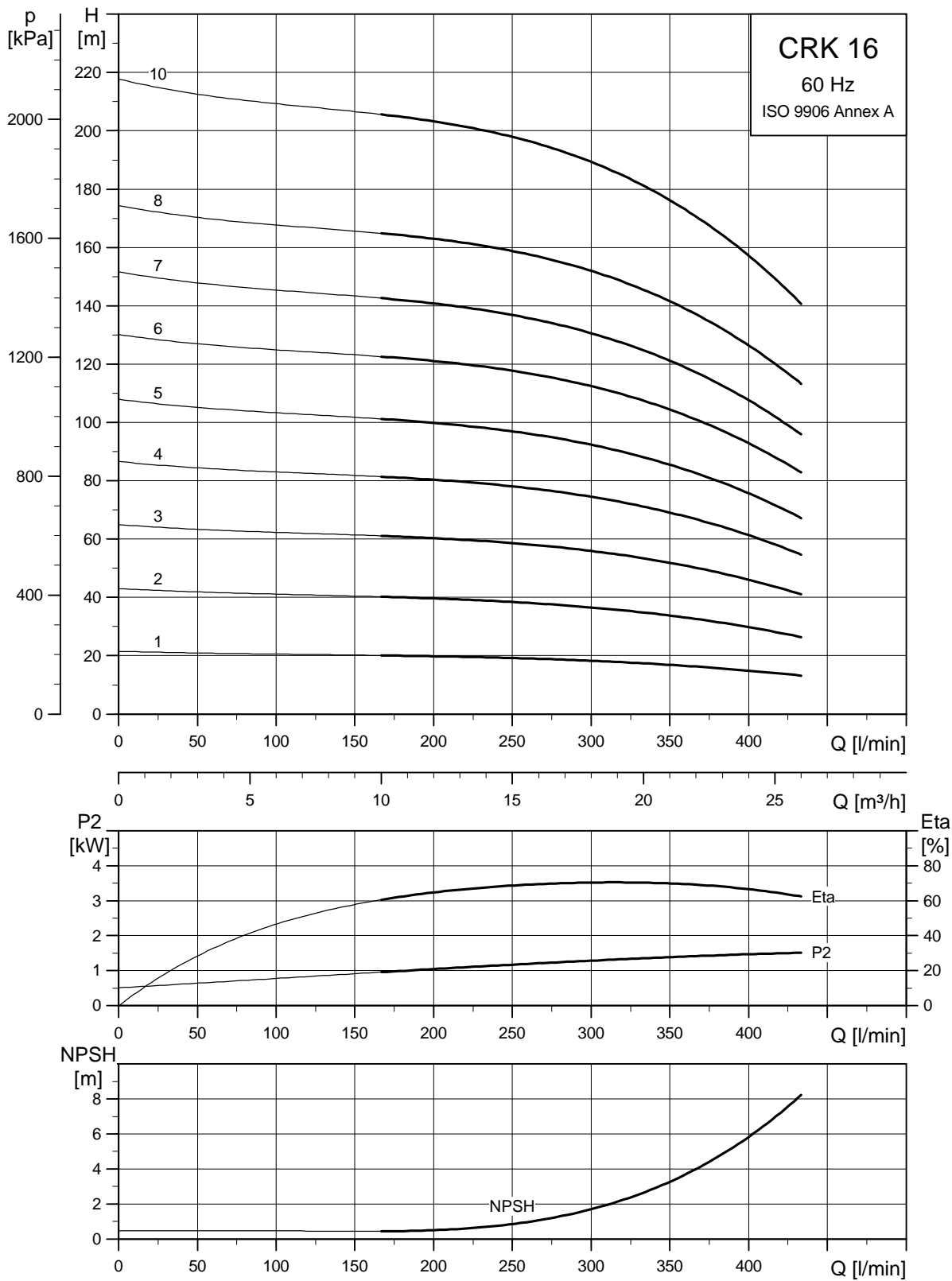

TM001949 3700

Dimensional sketches

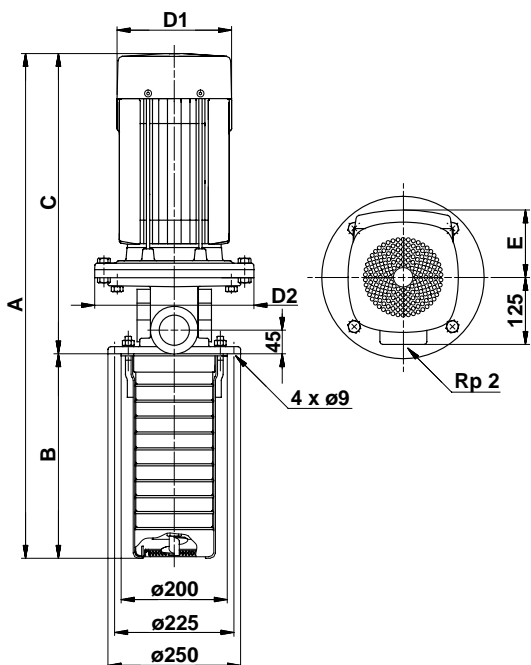

TM00 1921 3297

Dimensions and weights

Pump type	Dimensions [mm]						Weight [kg] ^a
	A	B	C	D1	D2	E	
CRK 16-20/1	598	178	420	178	140	110	41
CRK 16-20/2	653	178	475	178	160	110	45
CRK 16-30/3	758	223	535	220	300	134	62
CRK 16-40/4	803	268	535	220	300	134	67
CRK 16-50/5	848	313	535	220	300	134	68
CRK 16-60/6	1018	358	660	260	350	172	98
CRK 16-70/7	1063	403	660	260	350	172	99
CRK 16-80/8	1153	448	705	306	350	197	143
CRK 16-100/10	1243	538	705	306	350	197	145
CRK 16-120/10	1333	628	705	306	350	197	146
CRK 16-140/10	1423	718	705	306	350	197	147
CRK 16-160/10	1513	808	705	306	350	197	148

^a The stated weights apply to CRK only. For CRKI, add 1.3 kg.

Electrical data

3 x 220-277/380-480 V, 60 Hz

Pump type	Motor		Full load current $I_{1/1}$ [A]	Power factor $\cos \pi_{1/1}$	Motor efficiency ξ [%]	$\frac{I_{start}}{I_{1/1}}$
	Type	P_2 [kW]				
CRK 16-20/1	MG 90SA	1.5	5.70-5.00/3.30-2.90	0.89-0.78	80.5-82.0	5.90-8.40
CRK 16-20/2	MG 100LB	3.0	10.6-9.00/6.10-5.20	0.90-0.83	86.0-87.0	7.40-11.0
CRK 16-30/3	MG 132SB	5.5	18.8-15.6/10.8-9.00	0.92-0.85	87.5-89.5	8.20-12.4
CRK 16-40/4	MG 132SC	7.5	25.5-22.6/14.6-13.0	0.92-0.80	88.5-90.0	9.50-11.6
CRK 16-50/5	MG 132SC	7.5	25.5-22.6/14.6-13.0	0.92-0.80	88.5-90.0	9.50-11.6
CRK 16-60/6	MG 160MB	11.0	37.0-30.2/21.4-17.4	0.90-0.86	89.0-91.0	6.6-9.6
CRK 16-70/7	MG 160MB	11.0	37.0-30.2/21.4-17.4	0.90-0.86	89.0-91.0	6.6-9.6
CRK 16-80/8	160M	15.0	50.3-45.9/29.1-26.5	0.87	88.0	5.0-6.9
CRK 16-100/10	160M	15.0	50.3-45.9/29.1-26.5	0.87	88.0	5.0-6.9
CRK 16-120/10	160M	15.0	50.3-45.9/29.1-26.5	0.87	88.0	5.0-6.9
CRK 16-140/10	160M	15.0	50.3-45.9/29.1-26.5	0.87	88.0	5.0-6.9
CRK 16-160/10	160M	15.0	50.3-45.9/29.1-26.5	0.87	88.0	5.0-6.9

Industrial washing machine

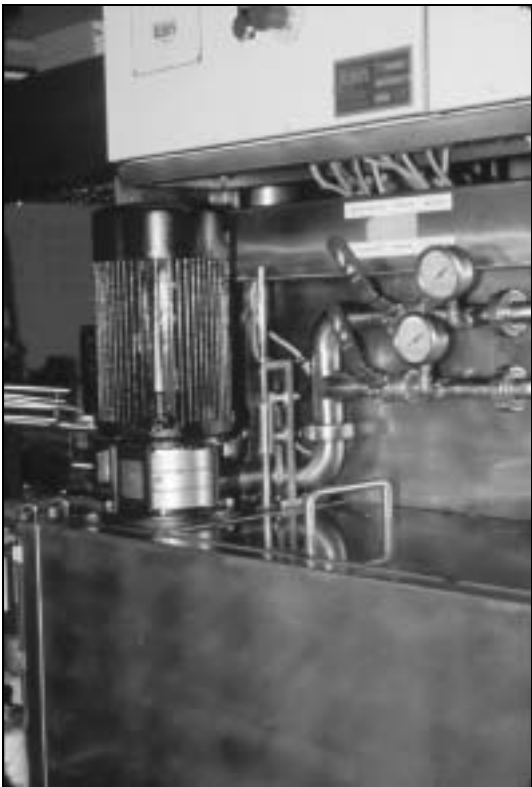

TM01 6013 1599



TM01 6017 1599

Pumping of coolant lubricants

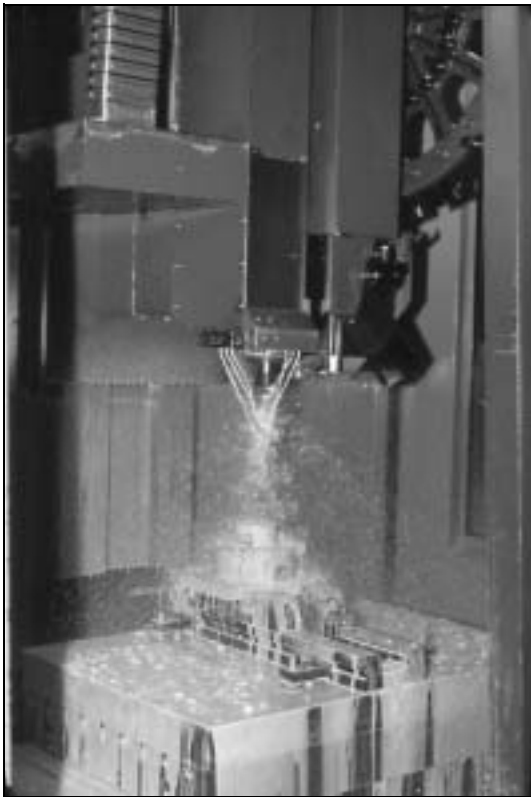

TM01 6014 1599

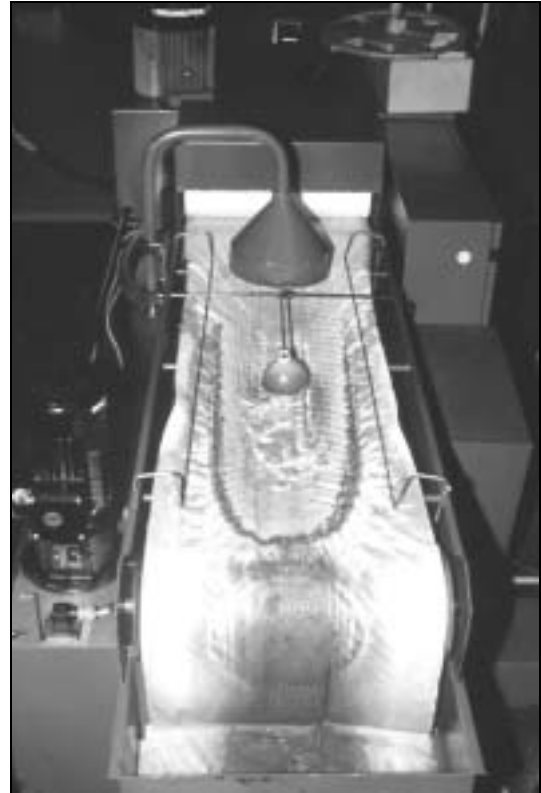

TM01 6015 1599



TM01 6016 1599

motralec

4 rue Lavoisier . ZA Lavoisier . 95223 HERBLAY CEDEX

Tel. : 01.39.97.65.10 / Fax. : 01.39.97.68.48

Demande de prix / e-mail : service-commercial@motralec.com

www.motralec.com

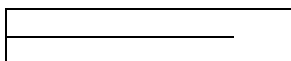

Subject to alterations.