

# Grundfos Home Booster

UPA 15-90, UPA 15-120, UPA 120  
50/60 Hz



be  
think  
innovate

**GRUNDFOS** 

<b>1. Product description</b>	<b>3</b>
Applications .....	3
Type key .....	3
Performance range .....	3
<b>2. Operating conditions</b>	<b>4</b>
Start-up .....	4
Pumped liquids .....	4
Temperature .....	4
Pressure .....	4
<b>3. Construction</b>	<b>5</b>
Sectional drawings UPA 15-90, UPA 15-120 .....	5
Sectional drawing UPA 120 .....	6
Motor UPA 15-90 (N) .....	7
Motor UPA 120 and UPA 15-120 .....	7
Rotor can .....	7
Shaft with rotor .....	7
Thrust bearing .....	7
Bearing plate .....	7
Impeller .....	7
Pump housing .....	7
Flow switch .....	8
<b>4. Installation</b>	<b>9</b>
<b>5. Performance curves</b>	<b>10</b>
Curve conditions .....	10
<b>6. Data sheets</b>	<b>11</b>
<b>7. Product numbers</b>	<b>25</b>
<b>8. Accessories</b>	<b>26</b>
External flow switch for UPA 120 .....	26
<b>9. Grundfos Product Center</b>	<b>27</b>

# 1. Product description

UPA 15-90, UPA 15-120 and UPA 120 circulator pumps are designed for pressure boosting of domestic water supplied from an external source in residential homes. UPA 15-90, UPA 15-120 and UPA 120 circulator pumps increase the pressure in order to make the required pressure available at showers, taps and other tapping points of domestic water.

UPA 15-90, UPA 15-120 and UPA 120 circulator pumps are used in open systems and can also be connected directly to the water main.

A flow switch starts or stops the pump when a tapping point is turned on or off. UPA 15-90 pumps have an integrated flow switch. UPA 15-120 pumps for China and Europe have an integrated flow switch. All other UPA 15-120 pumps and all UPA 120 pumps are supplied with an external flow switch, which has to be placed after the outlet of the pump.

All UPA circulator pumps are supplied with a cable and plug as required, and with fittings.

UPA 15-90, UPA 15-120 and UPA 120 circulator pumps offer a host of advantages:

- **Flexibility:** Suitable for installation in existing systems.
- **Comfort:** Low-noise operation.
- **User friendliness:** Plug and play.
- **Reliability:** Well known Grundfos quality.

## Applications

UPA 15-90, UPA 15-120 and UPA 120 circulator pumps are designed for pressure boosting of domestic water supplied from an external source in residential homes.

UPA 15-90, UPA 15-120 and UPA 120 circulator pumps supply the required pressure for showers, taps and other tapping points for domestic water.

UPA pumps are used in open systems and can also be connected directly to the water main.

## Type key

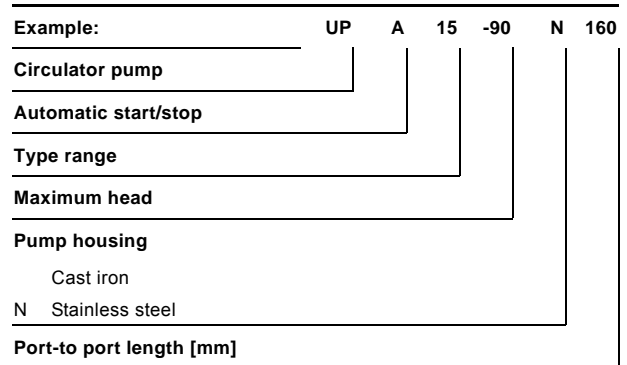

## Performance range

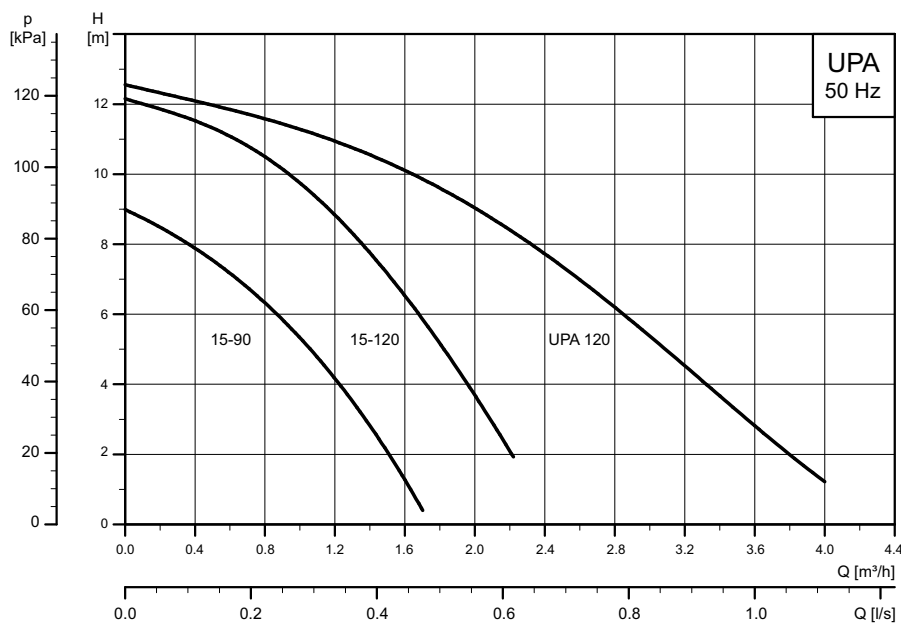

Fig. 1 Performance range UPA 15-90, UPA 15-120, UPA 120 (230 V, 50 Hz)

TM06 2280 3914

## 2. Operating conditions

### Start-up

The pump must not be started until the system has been filled with liquid and vented. Furthermore, the required minimum inlet pressure must be available at the pump inlet. The system cannot be vented through the pump.

The pump is self-venting and does not require venting before start-up.

### Pumped liquids

UPA 15-90, UPA 15-120 and UPA 120 circulator pumps are suitable for the these liquids:

- Fresh water
- Potable water without chemical additives
- Chlorinated potable water.

UPA 15-90, UPA 15-120 and UPA 120 circulator pumps are not suitable for the transfer of flammable liquids such as diesel oil and petrol.

### Temperature

Standard pumps	Max. [°C]	Min. [°C]
Liquid temperature	60/95/110	2
Ambient temperature	40	2

For liquid temperatures, please see also the [Data sheets](#) on page 10 and following.

### Pressure

#### Operating pressure

Pump version	Maximum operating pressure	
	[MPa]	[bar]
UPA 15-90	0.6	6
UPA 15-90 Netherlands UPA 15-90 Global	1.0	10
UPA 15-120	1.0	10
UPA 120	0.6	6
UPA 120 Mexico	1.0	10

For operating pressures, please see also the [Data sheets](#) on page 10 and following.

#### Inlet pressure

To avoid cavitation noise and risk of damage to the pump bearings, a minimum pressure of 2.0 m head/0.2 bar is required at the pump suction port during operation.

### 3. Construction

UPA 15-90, UPA 15-120 and UPA 120 circulator pumps for pressure boosting are of the canned-rotor type, i.e. pump and motor form an integral unit without shaft seal. Only two gaskets are required for sealing. The bearings are lubricated by the pumped liquid.

UPA 15-90, UPA 15-120 and UPA 120 circulator pumps are supplied with cable and plug.

Characteristic materials:

- Shaft: aluminium oxide or ceramic
- Radial bearing: ceramic
- Thrust bearing: carbon
- Rotor can and bearing plate: stainless steel
- Impeller: corrosion-resistant material
- Pump housing: cast iron or stainless steel.

#### Sectional drawings UPA 15-90, UPA 15-120

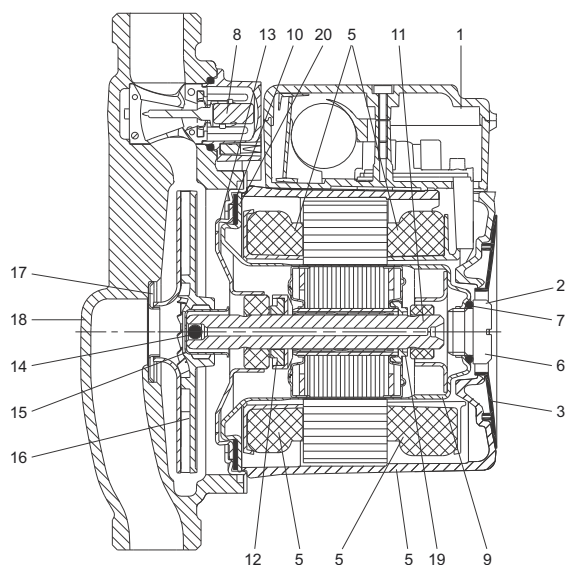

TM06 2996 0315

Fig. 2 Sectional drawing of UPA 15-90

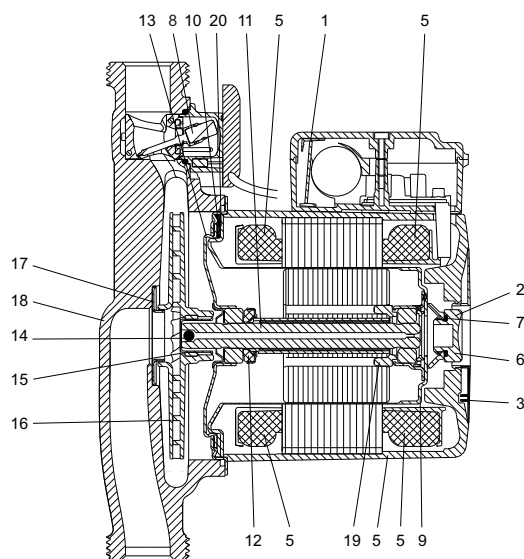

TM06 3444 0315

Fig. 3 Sectional drawing of UPA 15-120

#### Material specification UPA 15-90, UPA 15-120

Pos.	Description	Material	Material number EN	AISI
1	Terminal box	Composite PPE/PS		
	Terminal box cover	Composite PPE/PS		
	Electric unit	Composite PET		
2	Radial bearing	Ceramic		
3	Nameplate	Composite PA66		
5	Stator housing	AlSi10Cu2		
	Stator winding cap	Composite PET		
	Stator windings	Copper		
6	Air vent screw	Brass, nickelled, Ms58	2.0401.30	
7, 10	Gaskets	EPDM rubber		
8	Flow switch	Magnet / EPDM rubber / PP		
9	Rotor can	Stainless steel	1.4301	304
11	Shaft	UPA 15-90: aluminium oxide UPA 15-120: ceramic		
12	Thrust bearing	Carbon		
	Thrust bearing retainer	EPDM rubber		
13	Bearing plate	Stainless steel	1.4301	304
14	Ball (non-return valve)	EPDM rubber		
15	Split cone	Stainless steel	1.4301	304
16	Impeller	UPA 15-90: composite PP 30 % GF UPA 15-120: composite PSP/PP 30 % GF		
17	Neck ring	Stainless steel	1.4301	304
18	Pump housing	UPA 15-90 and UPA 15-120: cast iron	EN 1561 EN-GJL-150	ASTM 30 B
		UPA 15-90: stainless steel	1.4308	304 C15
19	Stop ring	Composite PES		
20	Intermediate ring	Stainless steel		

## Sectional drawing UPA 120

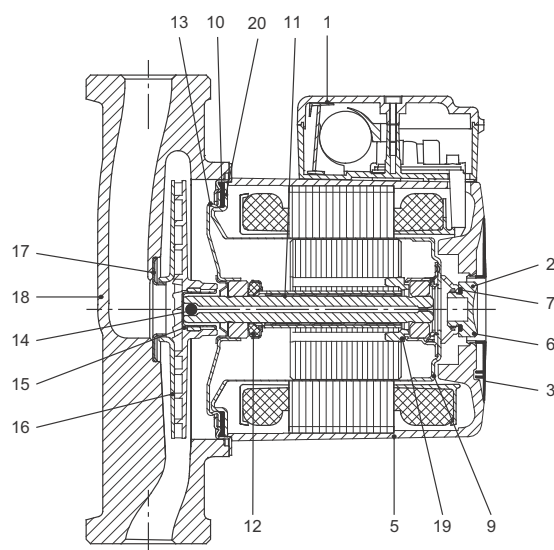

Fig. 4 Sectional drawing UPA 120

TM03 1652 2505

### Material specification UPA 120

Pos.	Component	Material	Material number EN	AISI
1	Terminal box	Composite PPE/PS		
	Terminal box cover	Composite PPE/PS		
	Electric unit (single-phase only)	Composite PET		
2	Radial bearing	Ceramic		
3	Nameplate	Composite PA66		
5	Stator housing	AISI10Cu2		
	Stator winding cap	Composite PET		
	Stator windings	Copper		
6	Air vent screw	Brass, nickelled, Ms58	2.0401.30	
7, 10	Gaskets	EPDM rubber		
9	Rotor can	Stainless steel	1.4301/1.4521	304
11	Shaft, complete	Ceramic		
12	Thrust bearing	Carbon		
	Thrust bearing retainer	EPDM rubber		
13	Bearing plate	Stainless steel	1.4301	304
14	Ball (non-return valve)	EPDM rubber		
15	Split cone	Stainless steel	1.4301	304
16	Impeller	Composite PSP/PP 30 % GF		
17	Neck ring	Stainless steel	1.4301	304
18	Pump housing	Cast iron	EN 1561 EN-GJL-150	
19	Stop ring	Composite PES		
20	Intermediate ring	Stainless steel	1.4301	304

## Motor UPA 15-90 (N)

The motor is a 2-pole, asynchronous, squirrel-cage motor. The motor has a built-in impedance protection and is short-circuit-proof. No external motor protection is required. The terminal box is easily accessible and has functional cable-connecting terminals. The cable entry is tight and incorporates cable relief.

## Motor UPA 120 and UPA 15-120

The motor is a 2-pole, asynchronous, squirrel-cage motor. The motor incorporates thermal overload protection. Therefore, no external motor protection is required. The terminal box is easily accessible and has functional cable-connecting terminals. The cable entry is tight and incorporates cable relief including the plug.

## Rotor can

The rotor can is closed with an air vent screw fitted directly at the top.

The upper radial bearing is incorporated in the top of the rotor can, and ground and honed with great precision.

## Shaft with rotor

The rotor is secured to the shaft with a pipe and an elastic sleeve. The rotor is totally encapsulated in a stainless-steel cladding. To avoid precipitation of calcium in the radial bearings, the shaft has been plunge-ground at the bearing entries.

The shaft has a through-going hole to ensure perfect lubrication and cooling of the upper bearing. See sectional drawings.

To prevent system water under pressure from running out when the air vent screw is removed, a non-return valve (rubber ball) is incorporated at the impeller end of the shaft.

The air in the rotor chamber escapes out into the system through the hole in the shaft.

## Thrust bearing

The thrust bearing is secured to the shaft by a spherically flexible suspension.

## Bearing plate

The lower radial bearing is pressed into the bearing plate, and ground and honed with great precision.

Due to the relatively large surface of the bearing plate, the motor heat is carried away from the rotor can by the pumped liquid.

## Impeller

The impeller is a radial impeller with curved composite blades. It is secured to the shaft by a split cone.

## Pump housing

### Standard (UPA 15-90, UPA 15-120)

The pump housing has a bore for a flow switch, and hydraulics have been adapted to the larger impeller. A stainless-steel ring equalises the dimensional difference between stator housing and pump housing.

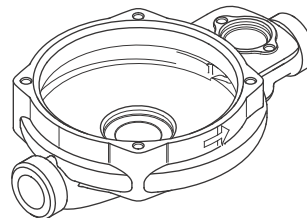

TM06 1411 2314

Fig. 5 Pump housing UPA 15-90 and UPA 15-120

The standard pump housing is made of cataphoresis-coated cast iron. The pump housing has a pressed-in neck ring to guide the liquid directly to the impeller.

The pump housing and the stator housing are assembled with four cheese-head screws.

### Stainless steel (UPA 15-90 N)

The cast stainless-steel pump housing has a pressed-in neck ring to guide the liquid directly to the impeller.

The pump housing and the stator housing are assembled with four cheese-head screws.

### Standard (UPA 120)

The hydraulics have been adapted to the larger impeller. A stainless-steel ring equalises the dimensional difference between stator housing and pump housing.

The standard pump housing is made of electro-coated cast iron. The pump housing has a pressed-in neck ring to guide the liquid directly to the impeller.

The pump housing and the stator housing are assembled with four cheese-head screws.

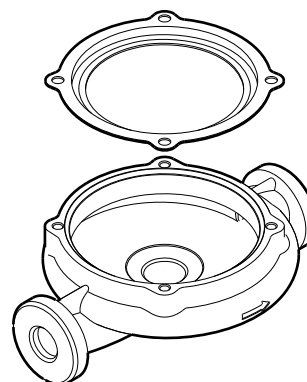

TM02 1327 0901

Fig. 6 Pump housing UPA 120

## Flow switch

### UPA 15-90

The flow switch consists of an arm with a magnet (1), that moves in a chamber (2). The chamber is separated from the pumped liquid and the terminal box. The magnetic field activates a magnetic contact (3).

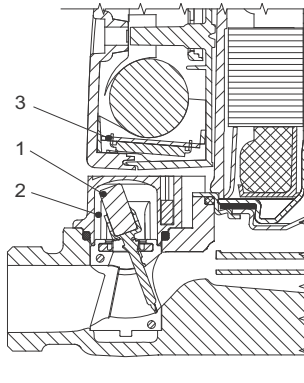

TM01 7 251 4199

**Fig. 7** UPA 15-90 flow switch in "OFF" position

The pump selector can be set to the positions "OFF", "AUTO" and "MANUAL".

Selector in positions		Description
I	OFF	The pump is switched off.
II	AUTO	The pump starts and stops automatically (when the flow exceeds or falls below 90-120 l/h).
III	MANUAL*	The pump runs continuously (even if tapping points are turned off).

\* When the selector is in position "MANUAL", at least one tap must be open. Otherwise the pumped liquid may become too hot.

### UPA 15-120

The flow switch consists of an arm with a magnet (1), that moves in a chamber (2). The chamber is separated from the pumped liquid and the terminal box. The magnetic field activates a magnetic contact (3).

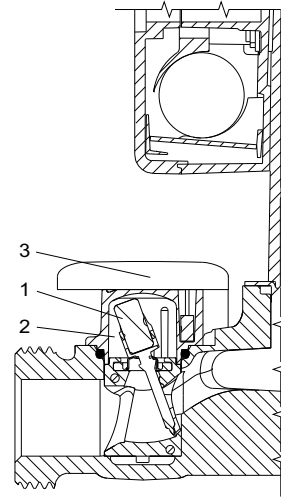

TM06 5104 3315

**Fig. 8** UPA 15-120 flow switch

The UPA 15-120 doesn't contain an On/Off switch.



## 4. Installation

The pump must always be installed with horizontal motor shaft. At start-up, the rotor can must be vented by removing the plug from the top of the motor.

Within a short time, the rotor forces the remaining air out into the system via the shaft.

UPA 120 and UPA 15-120 pumps can be installed vertically or horizontally. The mounting position is limited by the length of the cable between the external flow switch and the terminal box.

The terminal box of the UPA 15-90 has to be on the outlet of the pump, because of the built-in flow switch.

**Note:** As the pumps have drain holes, the terminal box must not face downwards.

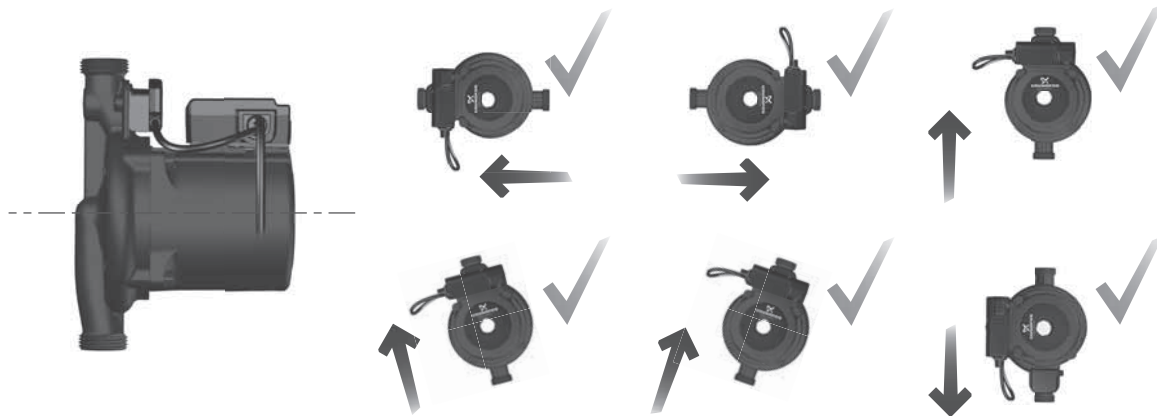

Fig. 9 Installation directions

TM06 2251 3814

## 5. Performance curves

### Curve conditions

The guidelines below apply to the performance curves on the following pages:

- Test liquid: airless water.
- The measurements for the UPA have been made at a water temperature of 20 °C.
- All curves show average values and should not be used as guarantee curves. If a specific minimum performance is required, individual measurements must be made.
- The curves apply to a kinematic viscosity of  $\nu = 1 \text{ mm}^2/\text{s}$  (1 cSt).
- The conversion between head  $H$  [m] and pressure  $p$  [kPa] has been made for water with a density of  $\rho = 1000 \text{ kg/m}^3$ . For liquids with other densities, for example hot water, the discharge pressure is proportional to the density.

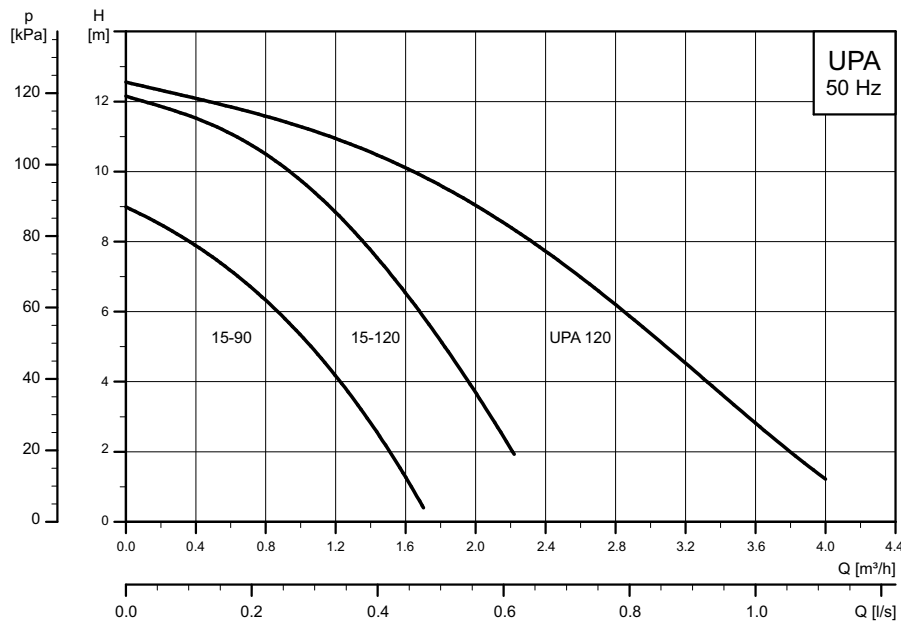

Fig. 10 Comparison of curves: UPA 15-90, UPA 15-120, UPA 120 (230 V, 50 Hz)

TM06 2280 3914

## 6. Data sheets

### UPA 15-90, 1 x 230 V, 50 Hz

China, Argentina, Czech Republic, Turkey, Romania, Indonesia

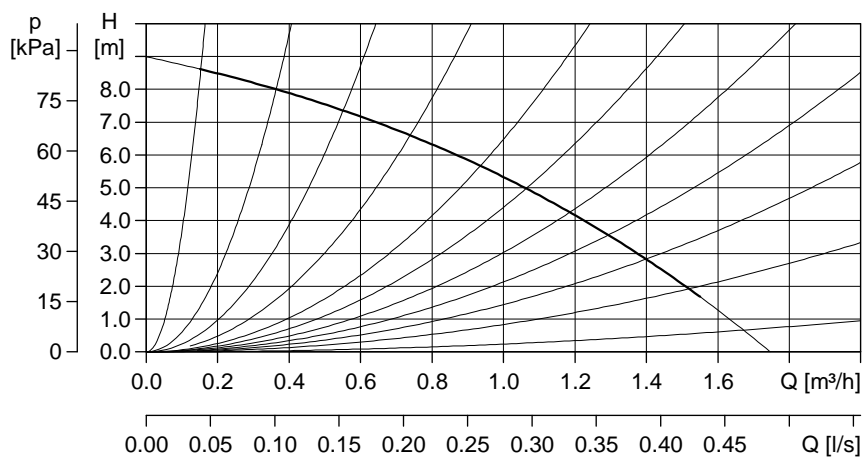

TM01 6893 3699

$P1_{max}$ [W]	$I_{1/1}$ [A]
120	0.48

Enclosure class: IPX2D  
 Connections: Rp 3/4 - Rp 1/2 unions  
 Operating pressure: Max. 6 bar  
 Liquid temperature: +2 °C to +95 °C (TF 95)

#### Dimensions

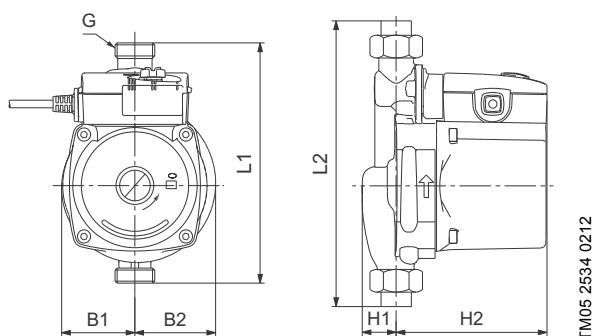

Pump type	Dimensions [mm]							Weights [kg]		Shipping volume [m³]
	L1	L2	H1	H2	B1	B2	G	Net	Gross	
UPA 15-90	160	214	23	103	50	54	3/4"	2.5	2.7	0.0042

# UPA 15-90, 1 x 110 V, 60 Hz

Brazil, Taiwan

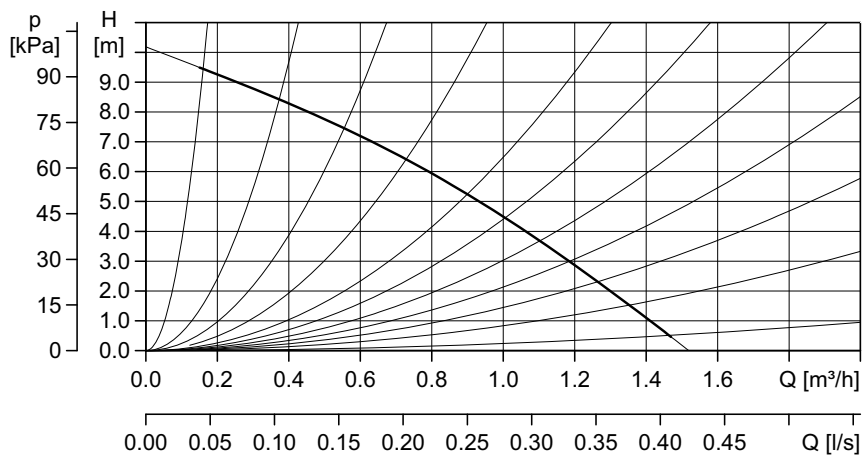

TM01 9635 2300

<b>P<sub>1max</sub> [W]</b>	<b>I<sub>1/1</sub> [A]</b>
120	1.0

Enclosure class: IPX2D  
 Connections: Rp 3/4 - Rp 1/2 unions  
 Operating pressure: Max. 6 bar  
 Liquid temperature: +2 °C to +95 °C (TF 95)

## Dimensions

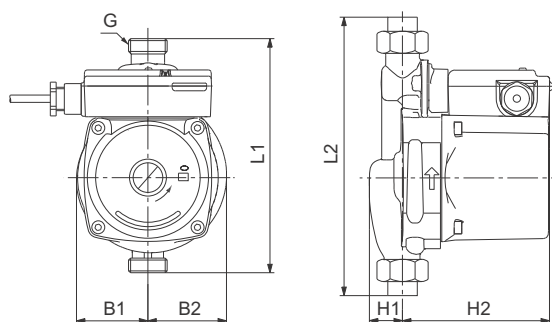

TM01 9639 2300

Pump type	Dimensions [mm]							Weights [kg]		Shipping volume [m³]
	L1	L2	H1	H2	B1	B2	G	Net	Gross	
UPA 15-90	160	214	23	103	50	54	3/4"	2.5	2.7	0.0042

# UPA 15-90 N, 1 x 240 V, 50 Hz

Singapore, Australia, New Zealand

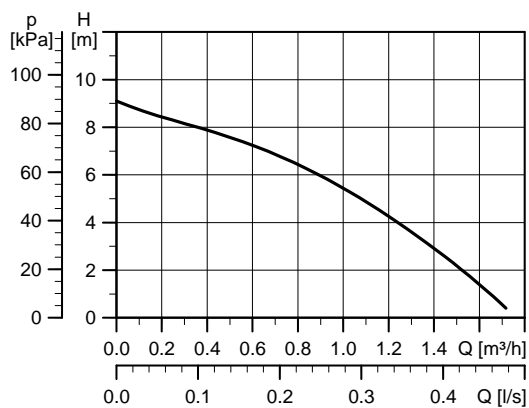

TM05 7460 1013

$P1_{max}$ [W]	$I_{1/1}$ [A]
120	0.48

Enclosure class: IPX2D  
 Connections: Rp 3/4 - Rp 1/2 unions  
 Operating pressure: Max. 6 bar  
 Liquid temperature: +2 °C to +95 °C (TF 95)

## Dimensions

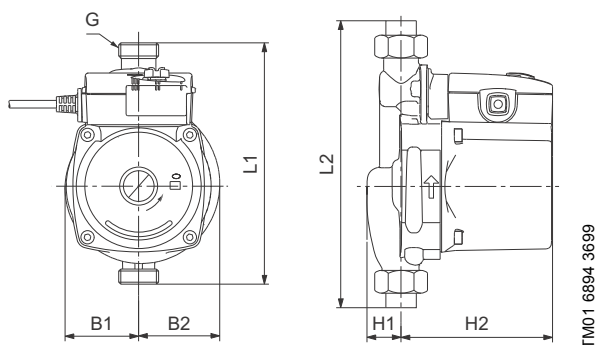

Pump type	Dimensions [mm]							Weights [kg]		Shipping volume [m³]
	L1	L2	H1	H2	B1	B2	G	Net	Gross	
UPA 15-90	160	214	23	103	50	54	3/4"	2.5	2.7	0.0042

## UPA 15-90, 1 x 220 V, 60 Hz

Brazil, Korea, Taiwan

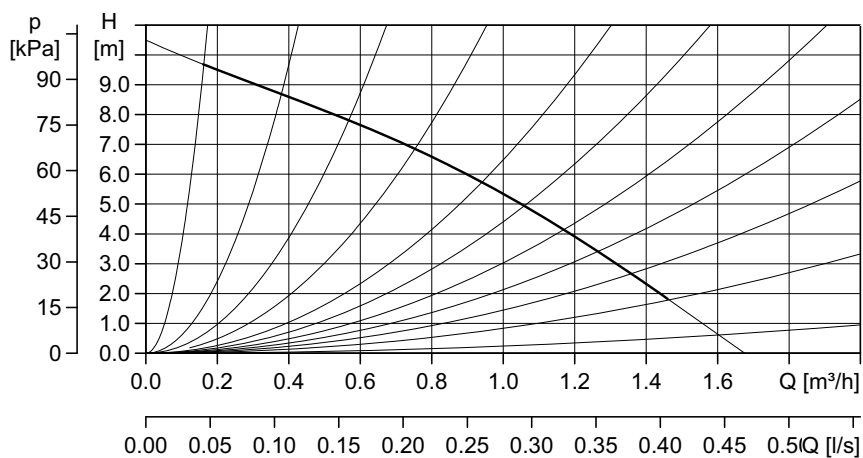

TM01 9636 2300

$P1_{max}$ [W]	$I_{1/1}$ [A]
120	0.48

Enclosure class: IPX2D  
 Connections: Rp 3/4 - Rp 1/2 unions  
 Operating pressure: Max. 6 bar  
 Liquid temperature: +2 °C to +95 °C (TF 95)

### Dimensions

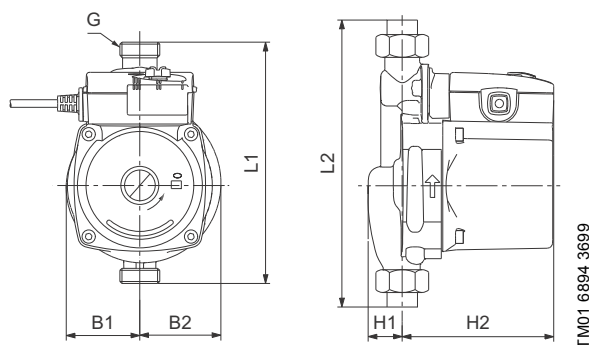

Pump type	Dimensions [mm]						Weights [kg]		Shipping volume [m³]	
	L1	L2	H1	H2	B1	B2	G	Net		Gross
UPA 15-90	160	214	23	103	50	54	3/4"	2.5	2.7	0.0042

# UPA 15-90 N, 1 x 100 V, 60 Hz

Japan

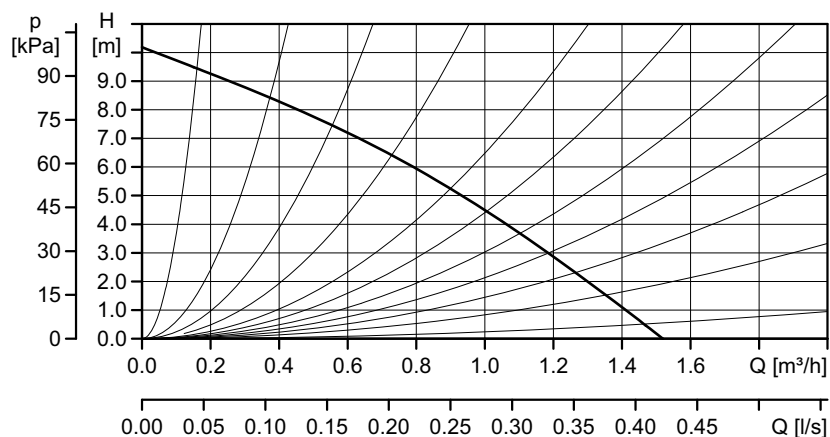

TM06 1927 3414

$P_{1\max}$ [W]	$I_{1/1}$ [A]
115	1.15

Enclosure class: IPX2D  
 Connections: Rp 3/4 - Rp 1/2 unions  
 Operating pressure: Max. 6 bar  
 Liquid temperature: +2 °C to +60 °C (TF 60)

## Dimensions

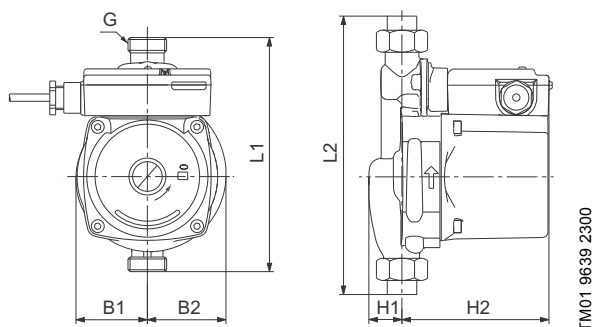

Pump type	Dimensions [mm]							Weights [kg]		Shipping volume [m <sup>3</sup> ]
	L1	L2	H1	H2	B1	B2	G	Net	Gross	
UPA 15-90 N	160	214	23	103	50	54	3/4"	2.5	2.7	0.0042

## UPA 15-90, 1 x 230 V, 50 Hz

UK, India, Russia, Global

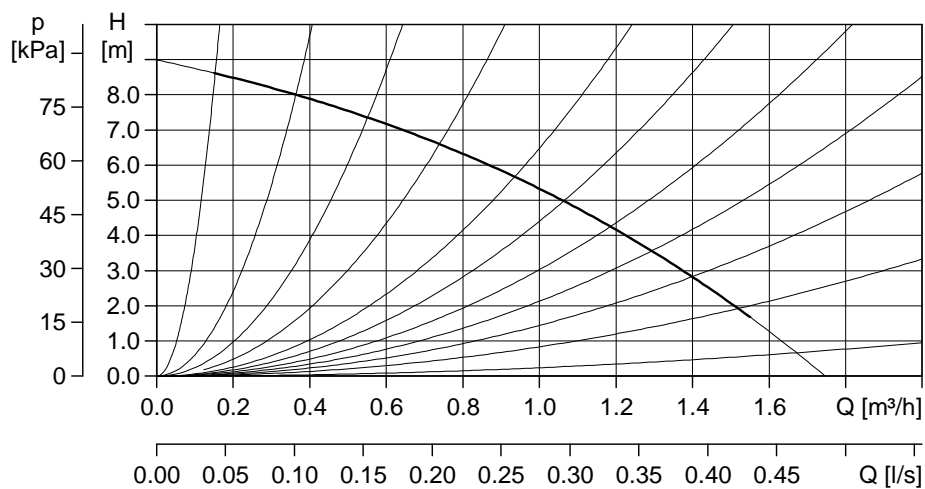

TM01 6893 3699

$P1_{max}$ [W]	$I_{1/1}$ [A]
120	0.48

Enclosure class: IPX2D  
 Connections: Rp 3/4 - Rp 1/2 unions  
 Operating pressure: Max. 6 bar / Max. 10 bar (Global only)  
 Liquid temperature: +2 °C to +95 °C (TF 95)

### Dimensions

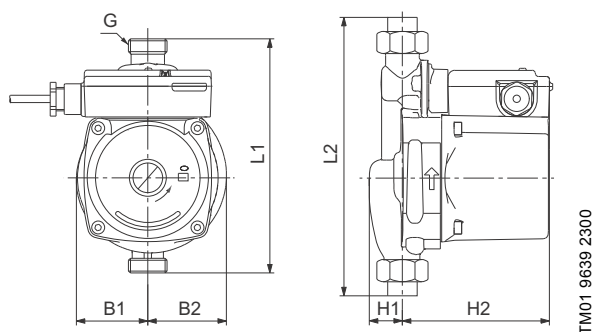

TM01 9639 2300

Pump type	Dimensions [mm]							Weights [kg]		Shipping volume [m <sup>3</sup> ]
	L1	L2	H1	H2	B1	B2	G	Net	Gross	
UPA 15-90	160	214	23	103	50	54	3/4"	2.5	2.7	0.0042



# UPA 15-90 N, 1 x 230 V, 50 Hz

Netherlands, UK

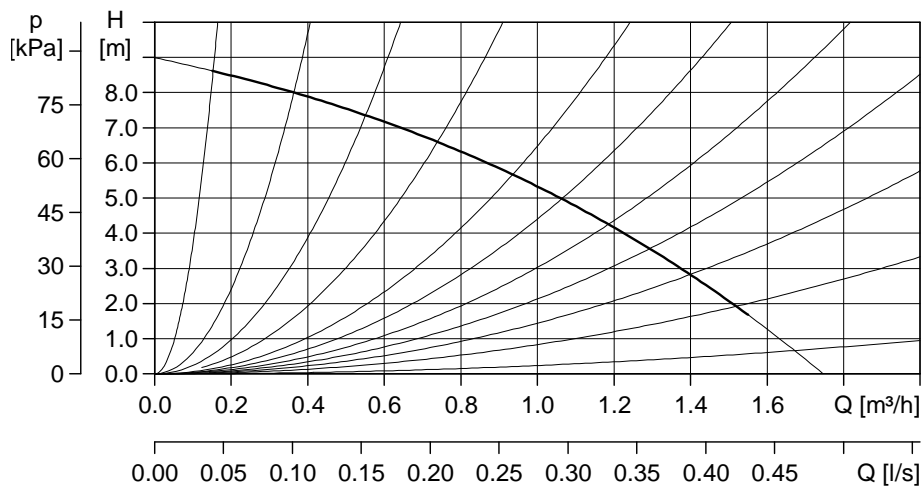

TM01 6893 3699

$P1_{max}$ [W]	$I_{1/1}$ [A]
120	0.48

Enclosure class: IPX2D  
 Connections: Rp 3/4 - Rp 1/2 unions  
 Operating pressure: Max. 6 bar / Max. 10 bar (Netherlands only)  
 Liquid temperature: +2 °C to +95 °C (TF 95)

## Dimensions

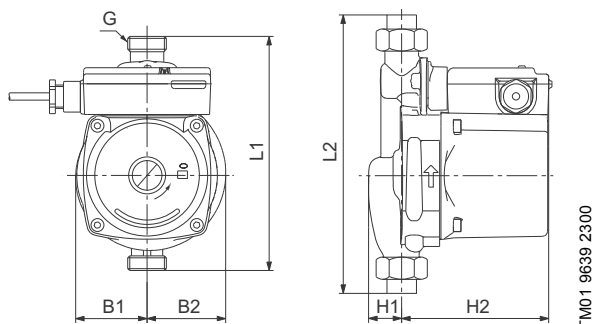

TM01 9639 2300

Pump type	Dimensions [mm]						Weights [kg]		Shipping volume [m³]	
	L1	L2	H1	H2	B1	B2	G	Net		Gross
UPA 15-90	160	214	23	103	50	54	3/4"	2.5	2.7	0.0042

# UPA 15-90, 1 x 127 V, 60 Hz

Mexico

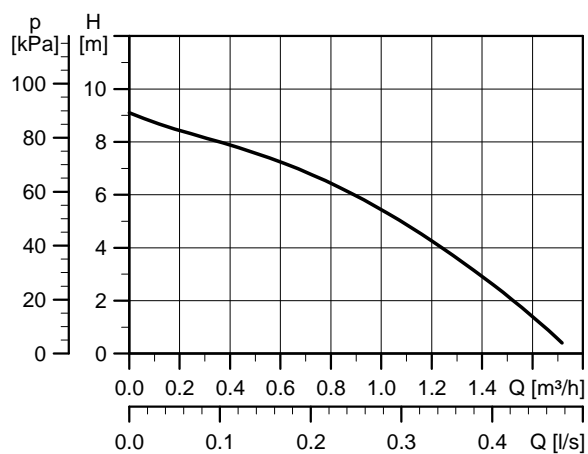

TM05 7460 1013

<b>P<sub>1max</sub> [W]</b>	<b>I<sub>1/1</sub> [A]</b>
120	1

Enclosure class: IPX2D  
 Connections: Rp 3/4 - Rp 1/2 unions  
 Operating pressure: Max. 6 bar  
 Liquid temperature: +2 °C to +60 °C (TF 60)

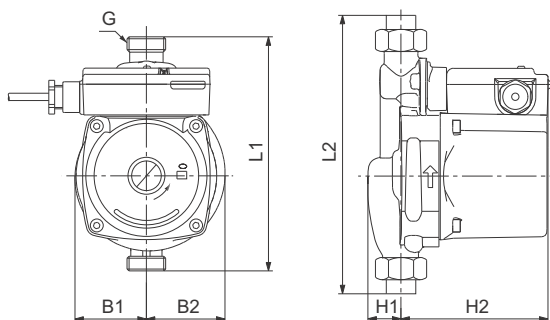

TM01 9639 2300

Pump type	Dimensions [mm]						Weights [kg]		Shipping volume [m³]	
	L1	L2	H1	H2	B1	B2	G	Net [kg]		Gross [kg]
UPA 15-90	160	214	23	103	50	54	3/4"	2.5	2.7	0.0042

# UPA 15-120, 1 x 230 V, 50 Hz

Europe

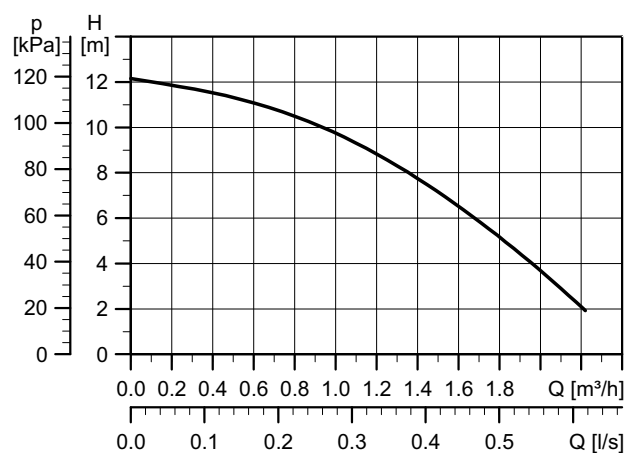

TM06 2052 3814

<b>P1<sub>max</sub> [W]</b>	<b>I<sub>1/1</sub> [A]</b>
200	0.89

Enclosure class: IPX2D  
 Connections: Rp 1 - Rp 1/2 unions  
 Operating pressure: Max. 10 bar  
 Liquid temperature: +2 °C to +95 °C (TF 95)

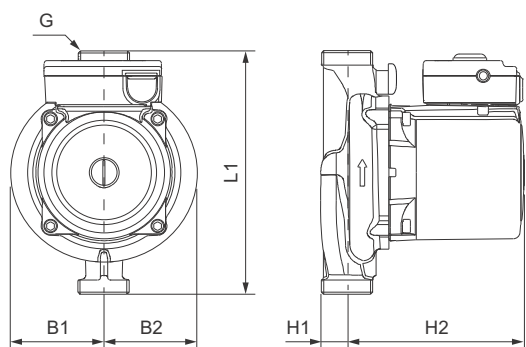

TM06 5103 3315

Pump type	Dimensions [mm]						Weights [kg]		Shipping volume [m³]
	L1	H1	H2	B1	B2	G	Net [kg]	Gross [kg]	
UPA 120	200	20	130	63	69	1"	4.7	5.1	0.0058

# UPA 15-120, 1 x 230 V, 50 Hz

China

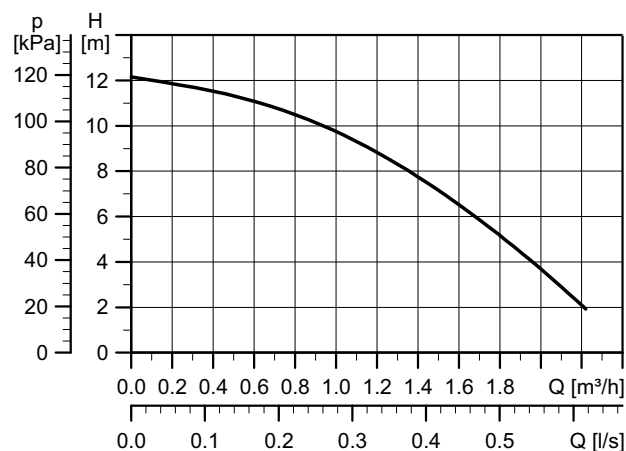

TM06 2052 3814

<b>P<sub>1max</sub> [W]</b>	<b>I<sub>1/1</sub> [A]</b>
200	0.89

Enclosure class: IPX2D  
 Connections: Rp 1- Rp 1/2 unions  
 Operating pressure: Max. 10 bar  
 Liquid temperature: +2 °C to +95 °C (TF 95)

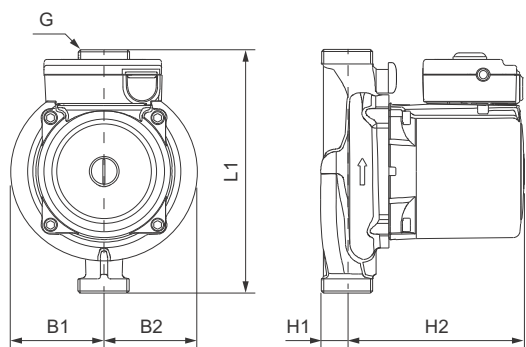

TM06 5103 3315

Pump type	Dimensions [mm]						Weights [kg]		Shipping volume [m³]
	L1	H1	H2	B1	B2	G	Net	Gross	
UPA 15-120	200	20	130	63	69	1"	4.7	5	0.0058

# UPA 120, 1 x 110 V, 60 Hz

Taiwan, Brazil

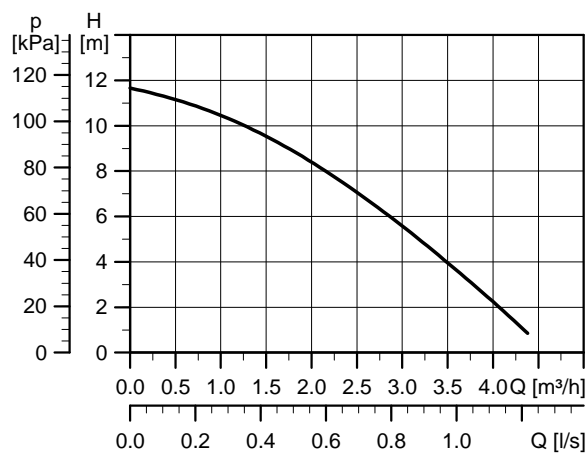

TM05 7458 1013

$P1_{max}$ [W]	$I_{1/1}$ [A]
215	2.1

Enclosure class: IPX2D  
 Connections: Rp 1 - Rp 1/2 unions  
 Operating pressure: Max. 6 bar  
 Liquid temperature: +2 °C to +110 °C (TF 110)

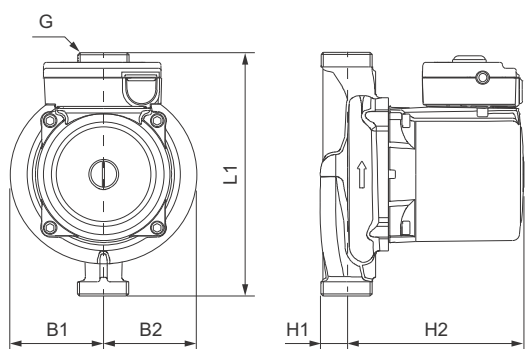

TM06 5265 4215

Pump type	Dimensions [mm]						Weights [kg]		Shipping volume [m³]
	L1	H1	H2	B1	B2	G	Net [kg]	Gross [kg]	
UPA 120	180	20	130	63	69	1"	4.7	5	0.0058

# UPA 120, 1 x 220 V, 60 Hz

Taiwan, Brazil, Korea

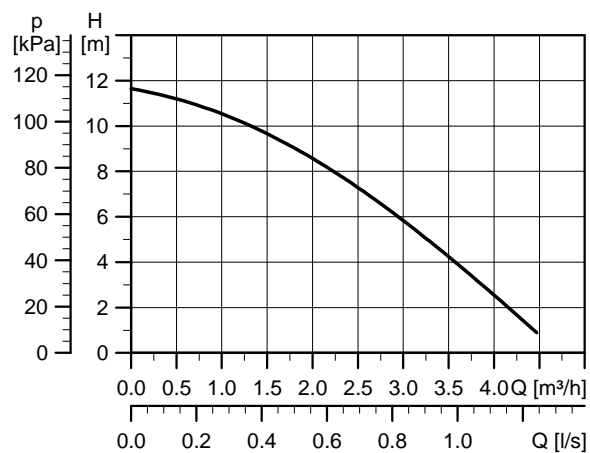

TM05 7462 1013

<b>P<sub>1max</sub> [W]</b>	<b>I<sub>1/1</sub> [A]</b>
220	1.05

Enclosure class: IPX2D  
 Connections: Rp 1 - Rp 1/2 unions  
 Operating pressure: Max. 6 bar  
 Liquid temperature: +2 °C to +110 °C (TF 110)

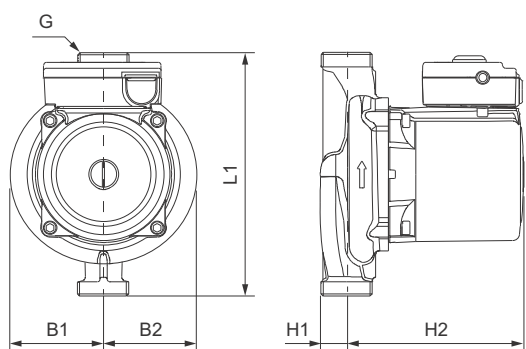

TM06 5265 4215

Pump type	Dimensions [mm]						Weights [kg]		Shipping volume [m³]
	L1	H1	H2	B1	B2	G	Net [kg]	Gross [kg]	
UPA 120	180	20	130	63	69	1"	4.7	5	0.0058

## UPA 120, 1 x 230 V, 50 Hz

Singapore, India, Argentina

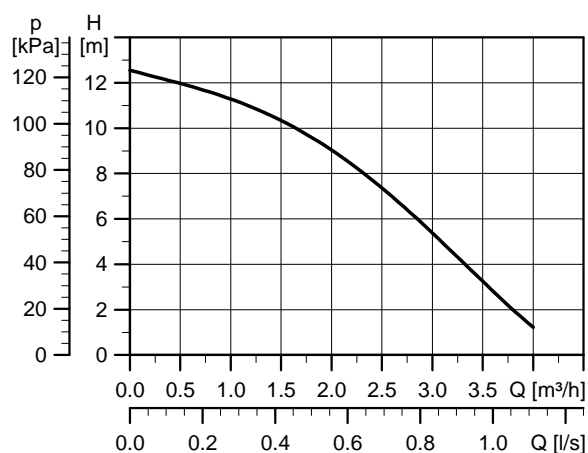

TM05 7459 1013

<b>P<sub>1max</sub> [W]</b>	<b>I<sub>1/1</sub> [A]</b>
250	1.14

Enclosure class: IPX2D  
 Connections: Rp 1 - Rp 1/2 unions  
 Operating pressure: Max. 6 bar  
 Liquid temperature: +2 °C to +95 °C (TF 95)

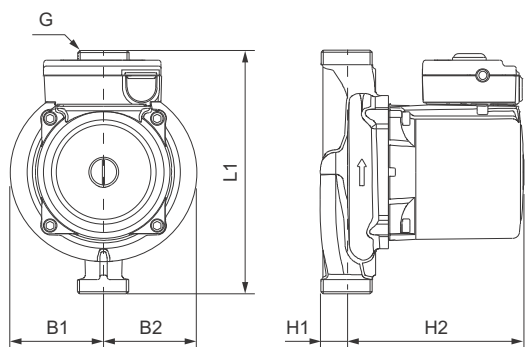

TM06 5265 4215

Pump type	Dimensions [mm]						Weights [kg]		Shipping volume [m³]
	L1	H1	H2	B1	B2	G	Net [kg]	Gross [kg]	
UPA 120	180	20	130	63	69	1"	4.7	5	0.0058

# UPA 120, 1 x 120 V, 60 Hz

Mexico

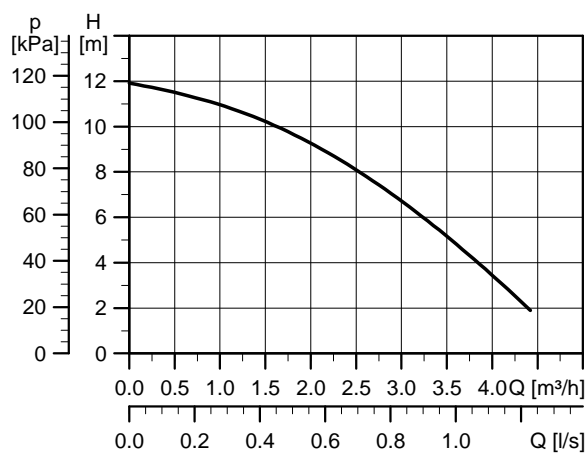

TM05 7463 1013

<b>P<sub>1max</sub> [W]</b>	<b>I<sub>1/1</sub> [A]</b>
225	2

Enclosure class: IPX2D  
 Connections: Rp 1 - Rp 1/2 unions  
 Operating pressure: Max. 6 bar  
 Liquid temperature: +2 °C to +110 °C (TF 110)

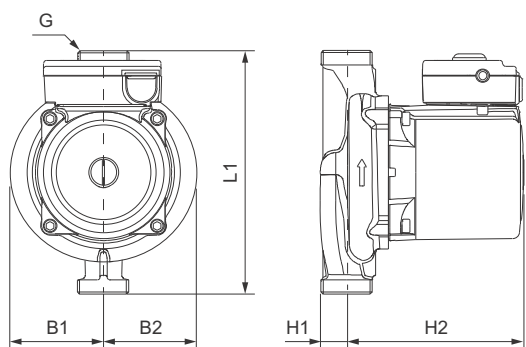

TM06 6265 4215

Pump type	Dimensions [mm]					Weights [kg]		Shipping volume [m³]	
	L1	H1	H2	B1	B2	G	Net [kg]		Gross [kg]
UPA 120	180	20	130	63	69	1"	4.7	5.1	0.0058



## 7. Product numbers

Market	Pump type	Port-to-port length [mm]	Terminal box position	Connection	Voltage [V]	Frequency [Hz]	Product number	Data sheet page
Argentina	UPA 15-90	160	12 H	G 3/4	230	50	59539502	<a href="#">11</a>
	UPA 120	180	12 H	G 1	230	50	52588423	<a href="#">23</a>
Australia and New Zealand	UPA 15-90 N	160	12 H	G 3/4	240	50	59539508	<a href="#">13</a>
Brazil	UPA 15-90	160	12 H	G 3/4	110	60	59539518	<a href="#">12</a>
	UPA 15-90	160	12 H	G 3/4	220	60	59539517	<a href="#">14</a>
	UPA 120	180	12 H	G 1	110	60	52588421	<a href="#">21</a>
	UPA 120	180	12 H	G 1	220	60	52588420	<a href="#">22</a>
Brazil (white colour)	UPA 15-90	160	12 H	G 3/4	110	60	98559024	<a href="#">12</a>
	UPA 15-90	160	12 H	G 3/4	220	60	98559114	<a href="#">14</a>
	UPA 120	180	12 H	G 1	110	60	98559136	<a href="#">21</a>
	UPA 120	180	12 H	G 1	220	60	98559140	<a href="#">22</a>
China	UPA 15-90	160	12 H	G 3/4	230	50	59539500	<a href="#">11</a>
	UPA 15-120	200	12 H	G 1	230	50	98699697	<a href="#">20</a>
Czech Republic	UPA 15-90	160	12 H	G 3/4	230	50	59539514	<a href="#">11</a>
Europe	UPA 15-120	200	12 H	G 1	230	50	98699677	<a href="#">19</a>
Global	UPA 15-90	160	12 H	G 3/4	230	50	59539521	<a href="#">16</a>
Netherlands	UPA 15-90 N	160	12 H	G 3/4	230	50	96621403	<a href="#">17</a>
India	UPA 15-90	160	12 H	G 3/4	230	50	59539511	<a href="#">16</a>
	UPA 120	180	12 H	G 1	230	50	52588416	<a href="#">23</a>
Indonesia	UPA 15-90	160	12 H	G 3/4	230	50	59539519	<a href="#">11</a>
Japan	UPA 15-90 N	160	12 H	G 3/4	100	60	59539505	<a href="#">15</a>
Korea	UPA 15-90	160	12 H	G 3/4	220	60	59539513	<a href="#">14</a>
	UPA 120	180	12 H	G 1	220	60	52588418	<a href="#">22</a>
Mexico	UPA 15-90	160	12 H	G 3/4	127	60	59539520	<a href="#">18</a>
	UPA 120	180	12 H	G 1	120	60	52588422	<a href="#">24</a>
Romania	UPA 15-90	160	12 H	G 3/4	230	50	59539516	<a href="#">11</a>
Russia	UPA 15-90	160	12 H	G 3/4	230	50	59539512	<a href="#">16</a>
Singapore	UPA 15-90 N	160	12 H	G 3/4	240	50	59539509	<a href="#">13</a>
	UPA 120	180	12 H	G 1	230	50	52588415	<a href="#">23</a>
Taiwan	UPA 15-90	160	12 H	G 3/4	110	60	59539506	<a href="#">12</a>
	UPA 15-90	160	12 H	G 3/4	220	60	59539507	<a href="#">14</a>
	UPA 120	180	12 H	G 1	110	60	52588413	<a href="#">21</a>
	UPA 120	180	12 H	G 1	220	60	52588414	<a href="#">22</a>
Turkey	UPA 15-90	160	12 H	G 3/4	230	50	59539515	<a href="#">11</a>
UK	UPA 15-90 N	160	12 H	G 3/4	230	50	97620721	<a href="#">17</a>
	UPA 15-90	160	12 H	G 3/4	230	50	59539510	<a href="#">16</a>

## 8. Accessories

### External flow switch for UPA 120



TM06 5193 4115

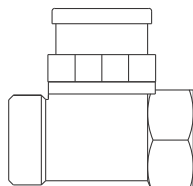

TM06 5162 3915

**Fig. 11** External flow switch for UPA 120

Description	Product number
External flow switch for UPA 120	91760166

## 9. Grundfos Product Center

Online search and sizing tool to help you make the right choice.

<http://product-selection.grundfos.com>



**SIZING** enables you to size a pump based on entered data and selection choices.

**REPLACEMENT** enables you to find a replacement product. Search results will include information on

- the lowest purchase price
- the lowest energy consumption
- the lowest total life cycle cost.

The screenshot shows the Grundfos Product Center website. At the top, there is a navigation bar with the Grundfos logo and 'PRODUCT CENTER'. Below this is a menu with options: HOME, FIND PRODUCT, COMPARE, YOUR PROJECTS, SAVED ITEMS, and HELP. A search bar is prominently displayed with the text 'Input product number or a whole or partial product name'. Below the search bar are four main navigation buttons: 'SIZING' (with a subtext 'Enter pump sizing'), 'CATALOGUE' (with a subtext 'Products and services'), 'REPLACEMENT' (with a subtext 'Replace an old pump with a new'), and 'LIQUIDS' (with a subtext 'Find pump by liquid'). The 'QUICK SIZING' section is visible, featuring input fields for 'Flow (Q)\*' (m³/h) and 'Head (H)\*' (m), and radio buttons for 'Select what to size by': 'Size by application', 'Size by pump design', and 'Size by pump family'. A 'START SIZING' button is located to the right of these options. At the bottom of the quick sizing section, there are links for 'ADVANCED SIZING' with sub-options for 'Advanced sizing by application' and 'Guided selection'.

**CATALOGUE** gives you access to the Grundfos product catalogue.

**LIQUIDS** enables you to find pumps designed for aggressive, flammable or other special liquids.

### All the information you need in one place

Performance curves, technical specifications, pictures, dimensional drawings, motor curves, wiring diagrams, spare parts, service kits, 3D drawings, documents, system parts. The Product Center displays any recent and saved items - including complete projects - right on the main page.

### Downloads

On the product pages, you can download installation and operating instructions, data booklets, service instructions, etc. in PDF format.

Subject to alterations.