

► Our technology. Your success.

Pumps • Valves • Service



CHTR – Centrifugal, High-pressure, Barrel Pump to API 610 Type BB5



Applications



Water injection



Refineries



Petrochemical industries



Steam generators



Seawater

Reliable delivery at high pressure.

Day in and day out, KSB pumps prove their worth again and again, delivering a consistently high level of quality and reliability. Are your pumps exposed to extreme temperatures and need to handle critical fluids? Do you require solutions to ensure a reliable performance under tough conditions? KSB can handle the pressure. Our team works hand in hand with engineers of the oil and gas industries to provide the most appropriate and efficient solution for your processes.

Optimum efficiency in all processes.

CHTR multistage barrel pumps are available in 5 sizes – with up to 16 stages and more than 30 hydraulic configurations. The modular design according to API 610 in its current condition guarantees the optimum and most efficient solution at all times. CHTR pumps can therefore be matched to the specific needs and requirements of a wide range of applications:

- Small capacities at high pressure
(Low Flow High Head application)
- Large capacities at medium and high pressure
- Operation around the clock
- Periodic operation at short intervals

Smooth operator in extreme situations.

Reliable KSB quality guarantees that processes in the oil and gas industries keep working at their best. The all-rounder CHTR offers several features to ensure everything runs smoothly – even under the most severe conditions. For example:

- Extremely durable rigid pump shafts
- Long interstage bushes and wear rings
- KSB expertise in selecting robust materials

Total Pump Management from KSB: individual concepts for highly efficient systems

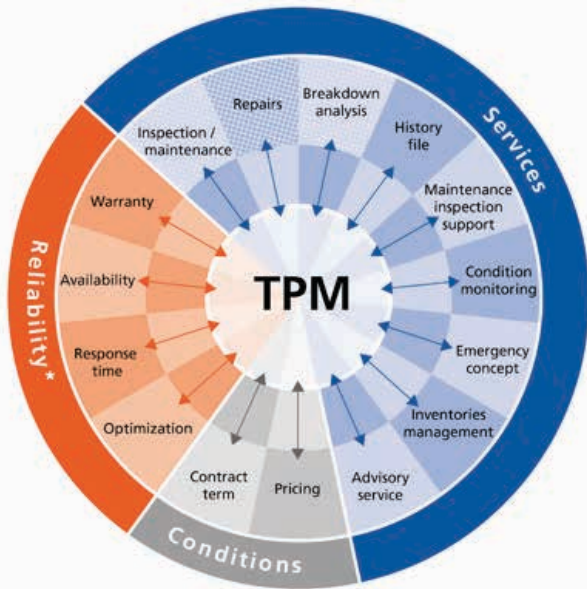

* only in combination with the inspection / maintenance, repairs and breakdown analysis services

This comprehensive service concept from KSB offers customers the chance to put together a service and spare parts package tailored to their specific requirements. Spare parts stocks, for example, can be structured far more efficiently thanks to our inventory management under a KSB service contract, significantly reducing costs.

- Ongoing support from pre-sales to after-sales
- Configuration of processes for maximum efficiency and minimum maintenance
- Reduction of stages to keep investment costs low
- NPSH values on lowest level through choice of single or double-entry suction stage impellers



CHTR – safe, service-friendly, system-compatible.

High reliability

- Strong antifriction or segmental thrust bearings hold the pump rotor in axial position and absorb residual axial thrust
- Optimised balance drum minimises axial thrust load on bearing and enables a longer service life
- Seal cavity dimensions to API 610
- Impellers secured individually and locked in direction of normal axial thrust, design to API 610
- Discharge pressure rating criteria for suction regions to API 610 on request

Long service life

- Plain bearing design reduces vibrations and wear
- Bearing check or replacement without dismantling the drive
- Pressure enclosure components designed to guidelines of ASME Sec. VIII Div. 1
- Flange ratings selected to match discharge pressure

High flexibility and adaptability

- Flange design meets loading requirements to API 610 – higher values on request

Reduced operating costs

- Top efficiency thanks to over 30 possible hydraulic configurations, by combining two special impeller with six diffuser configurations
- Improved efficiency through CFD optimized hydraulically contour on impellers and diffusers

Ease of maintenance

- Mechanical seals (cartridge design) can be easily dismantled and replaced without opening the pump
- Bearings can be monitored without opening the pump

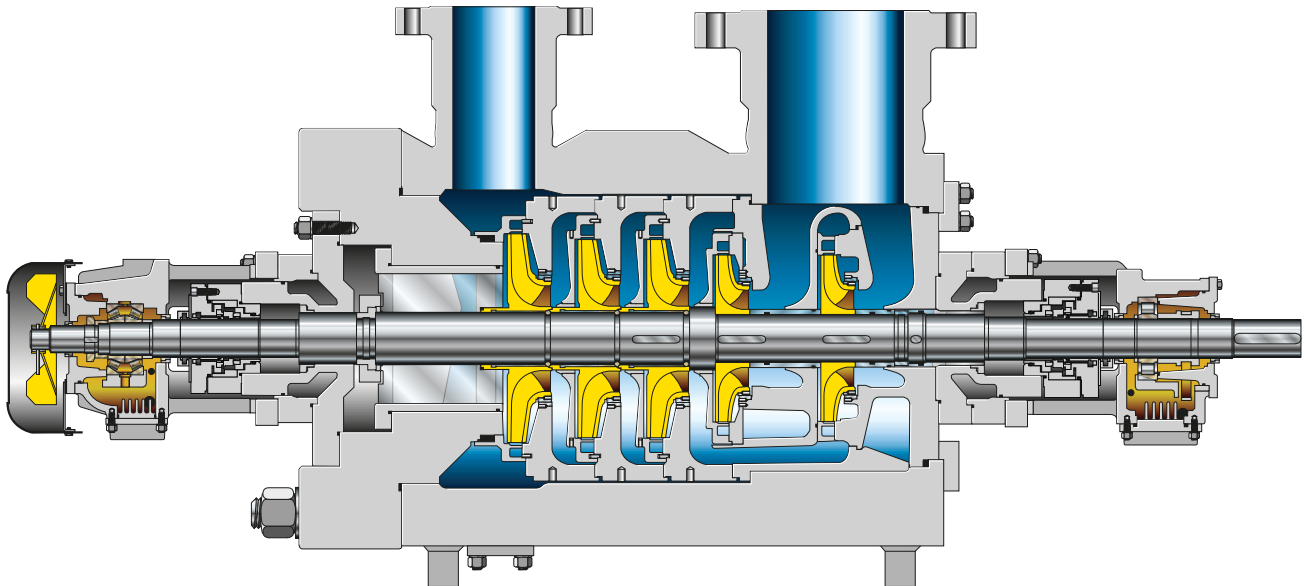



Bearing configurations

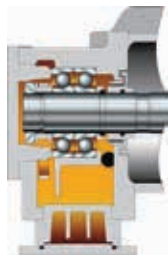

Antifriction bearings

- Oil ring lubrication
- Water-cooled bearing housing
- Provision for purge mist lubrication on request

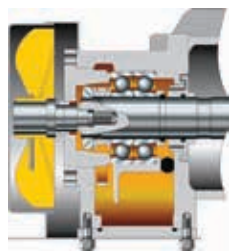

Bearing cooling (on request)

- fan cooling
- water cooled bearing

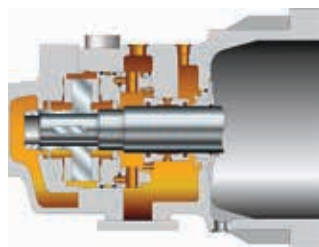

Heavy-duty thrust bearing design

- With forced-feed lubrication for higher loads/speed
- Special design to provide self-alignment feature for axial thrust bearing

Technical data and tables

Characteristic curves

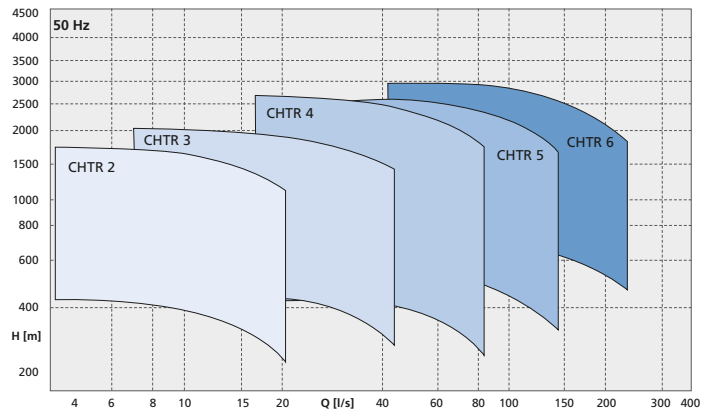
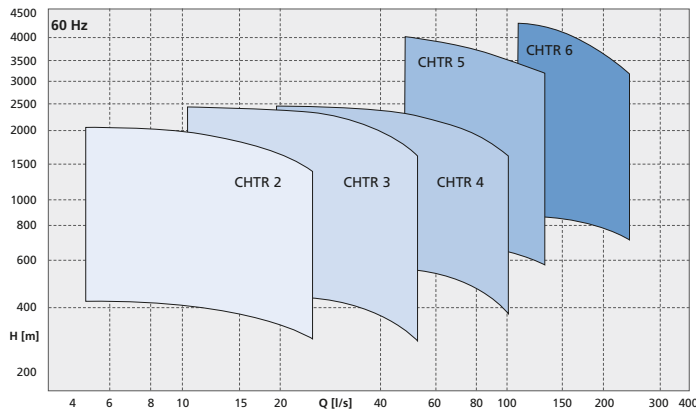

Technical data

Flow rate Q	up to 1,450 m ³ /h (400 l/s)
Head H*	up to 4,000 m
Temperature T	-60 °C to 450 °C
Pump discharge pressure p _d	up to 400 bar
Speed	up to 7,000 rpm
Size	DN 50 to DN 250

*Q = 0 and ρ = 1 kg/dm³

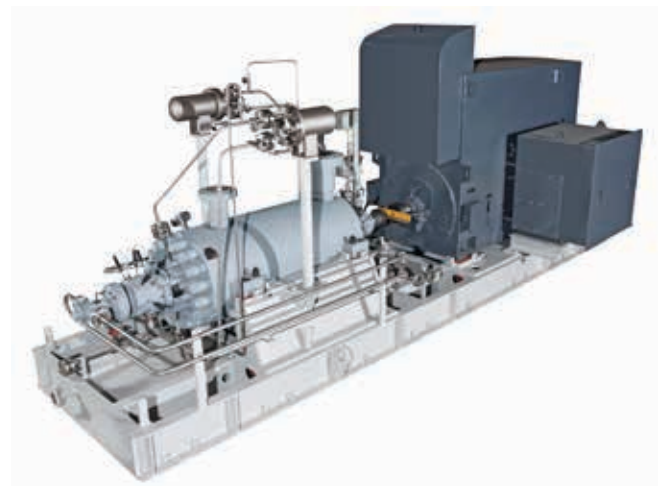

Materials

API 610 Major components**	S-5	S-6	C-6	A-8#	D-1#	D-2#
Barrel / Stage casing	C Steel	C Steel	Cr Ni Steel	AUS SS	Duplex	Super Duplex
Impellers / Diffusers	C Steel	Cr Steel		AUS SS	Duplex	Super Duplex
Impeller and stage casing wear rings / bushes	Cr Steel	Cr Steel		AUS SS*	Duplex*	Super Duplex*
Shaft	Cr Steel / CrNi Steel	Cr Steel / CrNi Steel	Cr Steel / CrNi Steel	AUS SS	Duplex	Super Duplex
Shaft sleeves (mech. seal)	AUS SS*	AUS SS*	AUS SS*	AUS SS	Duplex	Super Duplex
Cover / Casing Insert	C Steel	C Steel	CrNi Steel	AUS SS	Duplex	Super Duplex
Shaft Seal Housing	C Steel	C Steel	CrNi Steel	AUS SS	Duplex	Super Duplex

On special request

* Hard-faced

** further materials on customer request

C steel	Carbon steel
Cr steel	Chromium steel
CrNi steel	Chromium Nickel steel
AUS SS	Austenitic stainless steel
Duplex	Duplex stainless steel

Spectrum

Design	horizontal, radially split, multistage barrel -type pump, "quick pull-out" cartridge design										
Drive	Electric motor, steam turbine, combustion engine, gas turbine										
Rotation	clockwise viewed from drive end (suction site drive)										
Nozzels	Flange to ASME, radial, pointing vertically upwards, to DIN/BS on request										
Mounting	Shaft centerline										
Casing sealing	Confined spiral-wound stainless steel gaskets, O-ring for special applications										
Impellers	Radial flow, single entry, integrally cast										
Pump size		2		3		4		5		6**	
Pump discharge pressure p_d		100	250	100	250	100	250	100	250	100	250
Suction-Stage impeller	single entry	■	■	■	■	■	■	■	■	■	■
	double entry	X	X	X	X	■	■	■	■	■	■
Axial Thrust balancing	Hydraulically by single balance drum	■	X	■	X	■	X	■	X	■	X
	stepped balance drum	X	■	X	■	X	■	X	■	X	■
Bearing, lubrication											
Radial bearings	Antifriction bearings, splash-lubricated	■	X	■	X	■	X	■	X	■	X
	Plain bearings, forced-feed oil-lubricated	X	■	X	■	X	■	■	■	X	■
Thrust bearings	Antifriction bearings, splash-lubricated	■	X	■	X	■	X	■	X	■	X
	Segmental thrust bearing, forced-feed oil lubricated	X	■	X	■	X	■	■	■	■	■
Shaft seal	Mechanical seal to API 682										
Mechanical seal		■	■	■	■	■	■	■	■	■	■

X Not applicable ■ Applicable * on special request ** higher discharge pressure on special request

Easy to service

Quick pull-out of the complete cartridge unit is possible, only one bolted joint must be undone. The complete cartridge can be removed easily by means of a special device. The CHTR pump casing remains in the piping system. Therefore, suction and discharge flanges do not need to be disconnected. Wear condition of interior of the pump can be determined easily.

The cartridge design of CHTR barrel pumps allows dismantling and replacement of the inner assembly within only a few hours.

