

► Our technology. Your success.

Pumps • Valves • Service



Water where it is needed: with
axially split **volute casing pumps**



Get your business flowing – with KSB **volute casing pumps**

For more than 140 years, we have been offering our customers all-in solutions which comprise a broad spectrum of pumps, valves, drive and automation solutions as well as tailored services. A good example of the extraordinary results are our axially split volute casing pumps: Omega, RDLO and RDLP operate reliably and durably in the most diverse of applications. Our extensive hydraulic selection chart offers an optimum pump for every operating range:

- KSB's standardised high performers Omega and RDLO, single-stage volute casing pumps with double-entry impellers and a large range of options, cover all possible requirements.
- If even larger flow rates or heads are needed, our engineered RDLO and RDLP pump sets (with one, two or three stages, and double-entry impellers) are tailored precisely to the customer requirements and conditions at the site.

Wherever water is economically put into motion our axially split volute casing pumps and our expertise are sought after: we begin by consulting with our customers in the pre-project phase, we supply complete or partial solutions based on the particular specifications, and we continue to support the project right through to the end of processing and commissioning.



Versatility adds to their strength. This is why KSB's axially split volute casing pumps are optimum solutions, particularly in water applications. Our series of high-performance pumps move water where it is needed, from raw to clean to service water.

Volute casing pumps are the perfect match for many applications, for example:

- Water extraction in water utilities and desalination plants
- Pressure boosting and water transport
- Service and cooling water supply to power stations and industry
- Long-distance water supply
- Irrigation and drainage in pumping stations
- District cooling and heating systems
- Fire protection applications
- Marine and offshore engineering



The champions line up: Omega, RDLO and RDLP

Omega DN 80-350

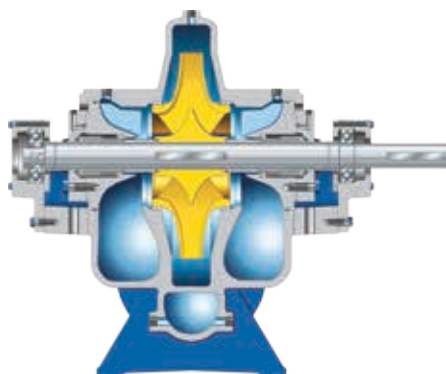

Description:

Single-stage axially split volute casing pump for horizontal or vertical installation with double-entry radial impeller, mating flanges to DIN, ISO, BS or ANSI.

Applications:

Pumping raw, clean and service water as well as seawater in water treatment plants, irrigation and drainage pumping stations, power stations, fire-fighting systems and shipbuilding.

Technical data:

DN	80 – 350 (3 – 14 in)
Q [m ³ /h]	2,880 max. (12680 gpm)
H [m]	210 (689 ft) max.
p [bar]	25 (363 psi) max.
T [°C]	140 (284 °F) max.
f [Hz]	50 (2-pole max.) 60 (2-pole max.)

RDLO DN 350-700

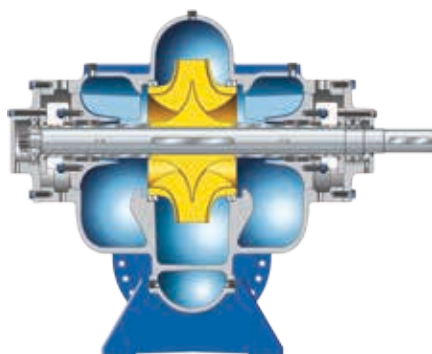

Description:

Single-stage, axially split volute casing pump for horizontal or vertical installation with double-entry radial impeller, mating flanges to DIN, ISO, BS or ANSI.

Applications:

Pumping raw, clean and service water as well as seawater in water treatment plants, irrigation and drainage pumping stations, power stations, fire-fighting systems and shipbuilding.

Higher flow rates and heads on request.

Technical data:

DN	350 – 700 (14 – 28 in)
Q [m ³ /h]	10,000 max. (44,030 gpm)
H [m]	290 (951 ft) max.
p [bar]	30 (435 psi) max.
T [°C]	140 (284 °F) max.
f [Hz]	50 (4-pole max.) 60 (4-pole max.)

RDLP DN 350-1200

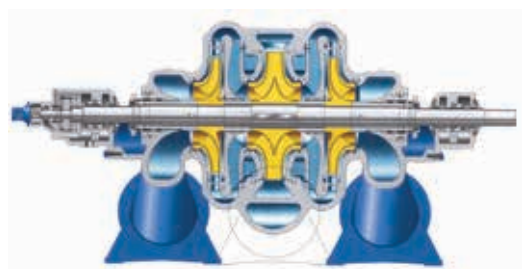

Description:

Axially split volute casing pump for horizontal installation, with one, two or three stages and double-entry radial impeller, mating flanges to DIN, ISO, BS or ANSI. Materials to DIN or ASTM in all required material combinations.

Applications:

Pumping raw, clean and service water as well as seawater.

Higher flow rates and heads on request.

Technical data:

DN	350 – 1,200 (14 – 48 in)
Q [m ³ /h]	18,000 max. (79,260 gpm)
H [m]	550 (1804 ft) max.
p [bar]	70 (1015 psi) max.
T [°C]	80 (176 °F) max.
f [Hz]	50 (4-pole max.) 60 (4-pole max.)

With KSB, everywhere is pole position

Our comprehensive and diverse product range is tailored to our customers' particular requirements. This is why we offer the most diverse of installation types, ensuring maximum flexibility and providing the right product for each application:

Horizontal installation types

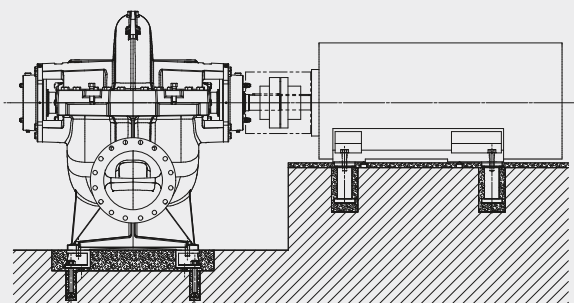

Pump and motor on foundation rails

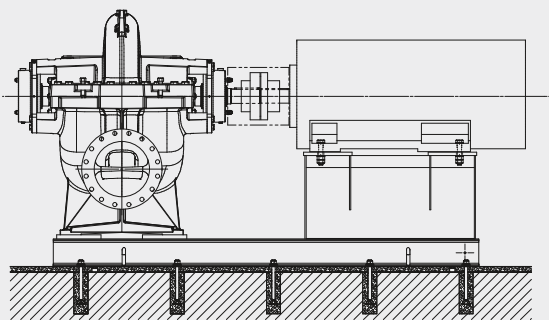

Pump and motor on a common baseplate

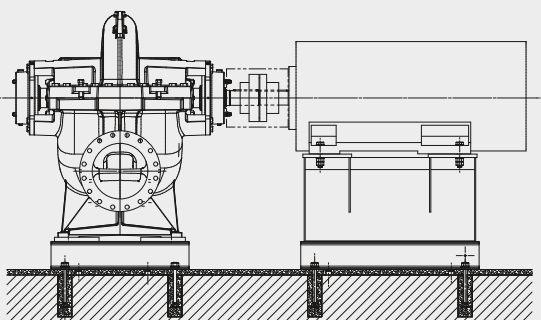

Pump and motor on separate baseplates

Vertical installation types

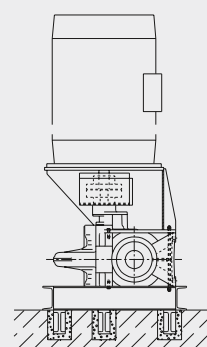

Pump with motor stool mounted on top

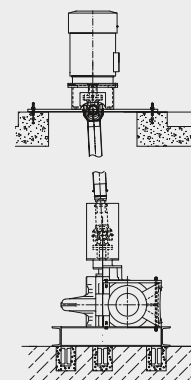

Pump and motor on separate levels

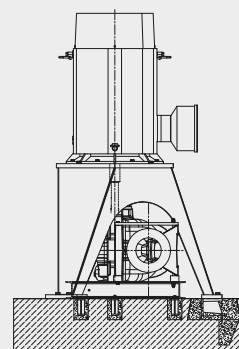

Pump with motor stool mounted separately



KSB. It's like a breath of fresh air

A "clean" alternative: KSB offers innovative products which contribute to reducing green house gas and carbon dioxide emissions in district heating and cooling applications.

KSB pumps – you'll really warm to them

District heating makes use of the heat gained by generating electricity in fossil-fuelled power stations for heating and other production processes. The waste heat is used to heat water that is then fed to the district heating network to be directly transferred to the buildings' central heating system via small transfer stations. District heating helps significantly reduce the fuel consumption for heat generation, and consequently the emission of pollutants. Omega and RDLO can be used for handling fluids of temperatures up to 140°C and are thus optimally suited for transporting the heated water. Their high reliability and efficiency makes them ideal for use in district heat supply systems.

KSB choice – that's what we call cool

In many regions, district cooling has already replaced conventional air-conditioning systems. More and more households abandon the idea of having their own small air-conditioning units in favour of benefiting from district cooling. The centralised supply allows to consume exactly the quantities actually required in each building, and offers efficiencies 5 to 10 times that of decentralised supply. This, in turn, lowers electricity consumption and CO₂ emissions. In district cooling, chilled water from chillers is distributed via a network of piping to the buildings to be cooled. Depending on the size of the district cooling networks, suitable pumps for the powerful and efficient transport of the chilled water include Omega and RDLO.

Systems expertise that sets standards

As a high-performance single-source supplier we focus on our products being safe, profitable and reliable. At KSB we are systems experts. We are here to help plant engineers, operators and consultants. Our volute casing pumps of the Omega, RDLO and RDLP series are a good example.

- High operating reliability and excellent efficiencies keep operating costs down
- Service-friendly design to the world's highest standards on quality, safety, reliability and durability
- Low maintenance costs and high availability
- Sustainable pump design with low life cycle costs

Whatever you need, it's here: the KSB hydraulic selection chart

At KSB customers have much to choose from: the large and varied range of hydraulic system designs covers the most diverse of requirements and customer specifications. We have got a proverbial eye for detail. And we have used it to develop a comprehensive hydraulic selection chart, offering our customers a wide range of choice in both operating data and material variants. Providing you with an economical solution is our focus.

The many options of KSB's hydraulic selection chart:

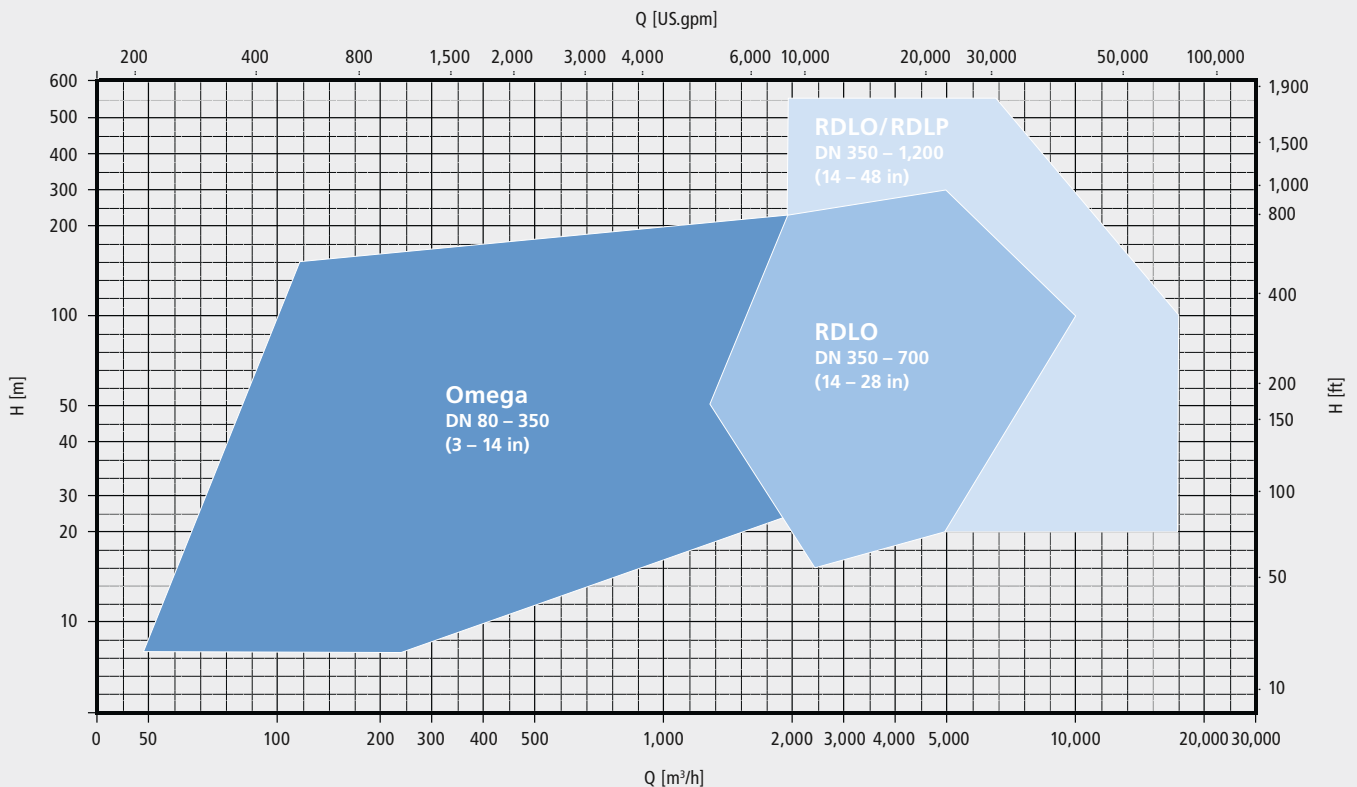

Actions speak louder than words: ask Omega, RDLO and RDLP

From pressure boosting, cooling and district heating to drinking water supply: rely on our axially split volute casing pumps and KSB's unique expertise for the most diverse water applications. Go to www.ksb.com/split-case for detailed information on a selection of reference objects.



1 Burj Khalifa Development Area, United Arab Emirates

Standing 860 metres tall, the 162-storey Burj Khalifa is the world's tallest building. The tower's air-conditioning is taken care of by a total of 31 KSB water transport pumps of the Omega type series. They are installed on pump levels which are located every 30 floors. Reliable and dependable KSB pumps transport up to 10,000 m³ of cooling water per hour.



2 Nepean Dam Deep Water Recovery Project, Australia

KSB helps supply Sydney with drinking water: three efficient KSB pumps of the RDLO series extract raw water at the lowest point of the Nepean Dam (WPS77 pumping station), and transport it to the filtration plant. Using pumps of the highest attainable efficiencies. This keeps energy costs down and considerably reduces the pumping station's life cycle costs. The design and modular structure of RDLO pumps allow them to be optimally matched to the customer's individual requirements.



3 Mékhé, Senegal

KSB lead-managed the installation of a state-of-the-art pressure booster system near the village of Mékhé. The pumping station is directly integrated into two continuous pipelines. KSB supported the engineering, the complete supply and the installation of the ready-to-use pumping station. In addition, KSB provided bespoke automation software for fully automatic operation of the system. In its initial extension phase the pumping station operates at a capacity of 190,000 m³ per day, provided by 3 + 1 variable speed RDLO 400-880A pumps.



4 Ravenswood, Australia

Drinking water for Perth: the Ravenswood pumping station is part of the Southern Seawater Desalination Plant (SSDP). Up to 265 million litres of drinking water can be transported to Perth drawing on the Tamworth reservoir and the North Dandalup Dam. For both facilities, KSB supplied RDLO and RDLP pumps. They not only kept down the life cycle costs and the amount of construction work needed on site, but also outran the warranted performance data during intensive testing.



5 Airport Road and Beckett Sproule, Canada

Built in 2005, the Airport Road station with storage basin and pumping station supplies clean drinking water to three major growth regions in Ontario. In 2010, KSB won an order for equipping the second pumping station, Beckett Sproule, and supplied 6 RDLO pumps. Following this, another 6 pumps of this type series were needed at the Airport Road pumping station in 2011. RDLO pumps are versatile and allow maximum energy savings – during the hydraulic acceptance test the pumps' efficiency even topped the ratings warranted in the quotation.



6 Mambu Branco System, Brazil

The Mambu Branco facility is part of the integrated water supply system located on the south coast of the São Paulo state. The extension of the system included building a dam, pumping stations as well as a treatment plant for which KSB Brazil not only supplied horizontal, radially split RDLO and RDL as well as submersible Amacan and Hydrobloc-Drainer pumps, but also horizontal overhung Meganorm and Megaflow pumps. Dependability, reliable operation and maintenance-friendly design were decisive arguments to place the order with KSB.

Built to stay with you: technology made by KSB

Today's market is increasingly calling for high-performance, high-quality pumps. We use state-of-the-art technologies to design our axially split volute casing pumps and manufacture them using a continuously optimised production process. On our in-house test beds – suitable for electric motors with a rating of up to 10 MW – we test our pump sets under real, extreme operating conditions. This is how we make sure our products meet the highest of requirements on safety, reliability and efficiency.

All pump components are 3D CAD-designed and saved as 3D data which can later be used for flow simulation as well as for strength and vibration analyses. 3D data are also made use of for casting pattern and mechanical production.

- FEM strength analysis – optimises the design and dimensions of components
- FEM vibration analysis – serves to calculate the natural frequency to prevent any damage from vibration resonance
- CFD flow simulation – helps to select and optimise hydraulic components
- CAM NC programming and production simulation

We meet high quality and performance standards – by thinking all the way, and acting accordingly. So high performance from A to Z also characterises the entire production process. All production steps are perfectly tuned to each other and cover anything the customer may need: from welding technology and mechanical production to the assembly of complete pump sets, test runs and shipment.



CFD flow simulation

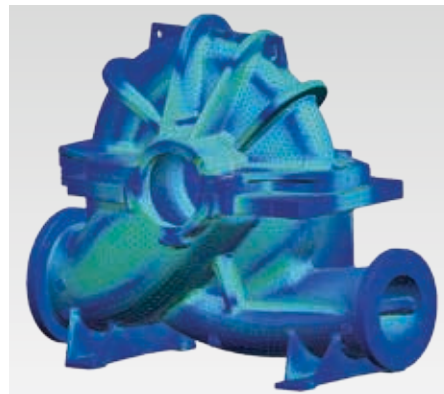

FEM model

Tested the hard way, all the way

At KSB we thoroughly test all our products on the test bed under real operating conditions. Our test beds are at the front of technology, worldwide:

- The complete RDLO series can be tested at full speed
- Suitable for pumps or pump sets with a rating of up to 10 MW
- The closed test loop ensures optimum adjustment to the suction pressure
- State-of-the-art control technology ensures efficient operation
- A frequency inverter of the latest generation enables test runs with customer-supplied motors
- Comprehensive sound insulation enables 24-hour, 3-shift test bed operation

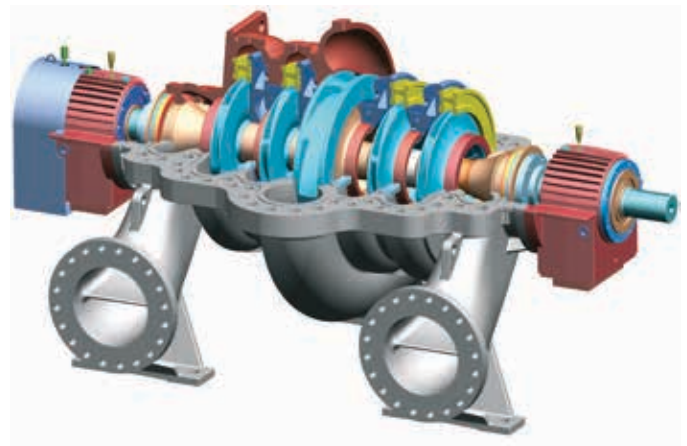

CAD model of RDLP

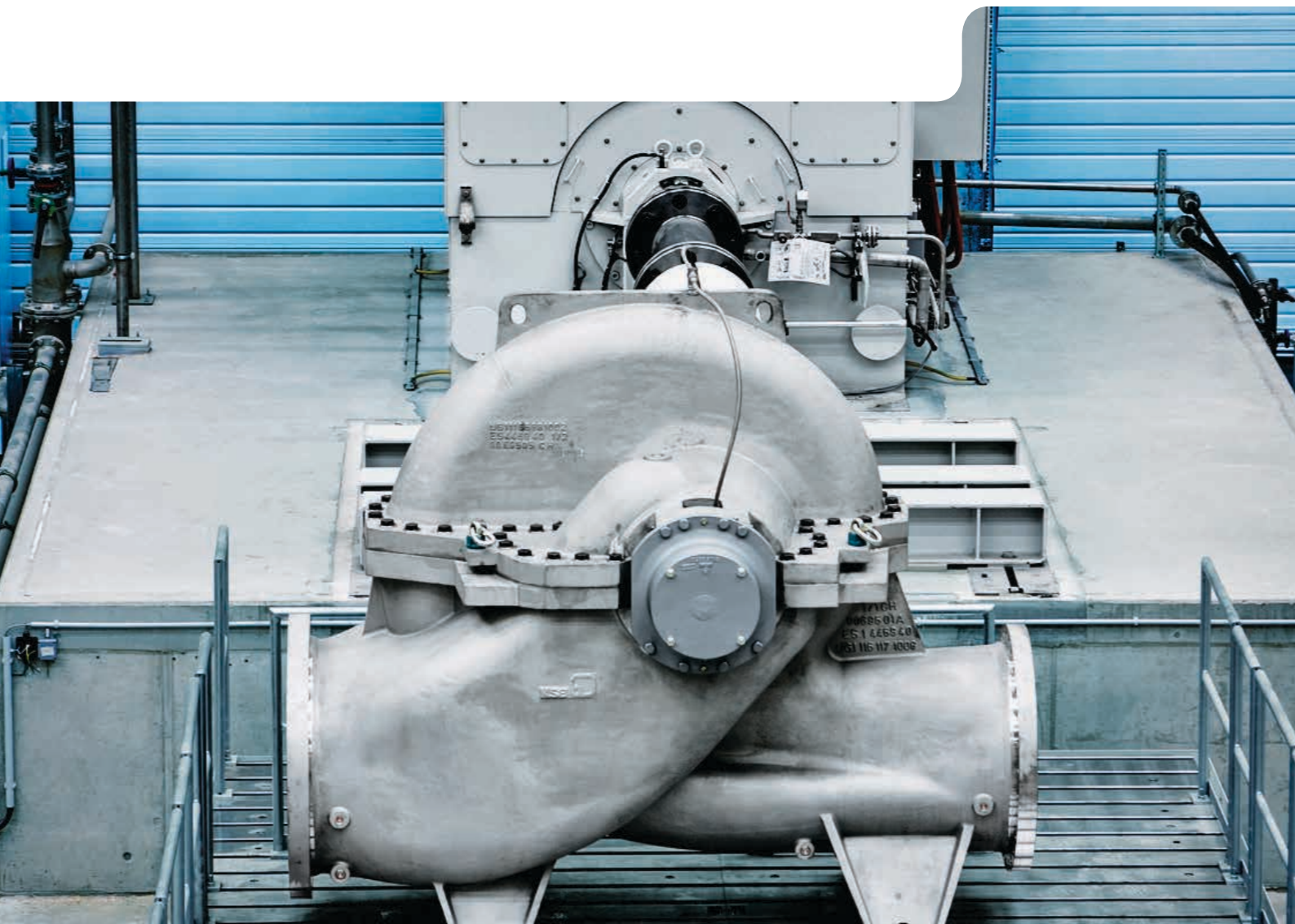



Technology that **makes its mark**

The KSB newsletter –
don't miss out, sign up now:
www.ksb.com/newsletter



Your local KSB representative:



KSB SE & Co. KGaA
Johann-Klein-Straße 9
67227 Frankenthal (Germany)
www.ksb.com

You can also visit us at
www.ksb.com/socialmedia