

## Boiler Feed Booster Pump

# YNK

## Type Series Booklet



## **Legal information/Copyright**

Type Series Booklet YNK

All rights reserved. The contents provided herein must neither be distributed, copied, reproduced, edited or processed for any other purpose, nor otherwise transmitted, published or made available to a third party without the manufacturer's express written consent.

Subject to technical modification without prior notice.



## Contents

<b>Energy</b> .....	<b>4</b>
Boiler Feed Booster Pump .....	4
YNK .....	4
Main applications.....	4
Fluids handled .....	4
Operating data.....	4
Designation .....	4
Design details .....	5
Materials.....	7
Dimensions .....	8
General assembly drawings with list of components .....	11

## Energy

### Boiler Feed Booster Pump

## YNK



### Main applications

- Feed water transport in power stations
- Condensate transport in power stations
- Boiler feed booster pump in systems with low suction head

### Fluids handled

- Feed water
- Condensate
- High-temperature hot water

### Operating data

Operating properties

Characteristic		Value
Flow rate	Q [m <sup>3</sup> /h]	≤ 4500 <sup>1)</sup>
	Q [l/s]	≤ 1250 <sup>1)</sup>
Head <sup>2)</sup>	H [m]	≤ 370 <sup>1)</sup>
Fluid temperature	T [°C]	≤ 210
Inlet pressure	p <sub>s</sub> [bar]	≤ 20
Discharge pressure <sup>2)</sup>	p <sub>d</sub> [bar]	≤ 40
Speed	n [rpm]	≤ 1800

### Designation

Example: YNK 500/800

Designation key

Code	Description
YNK	Type series group
500	Nominal discharge nozzle diameter [mm]
800	Maximum outside diameter of the impeller (nominal) [mm]

1) At maximum permissible speed

2) Q = 0, ρ = 1 kg/dm<sup>3</sup>



## Design details

### Design

- Radially split volute casing pump with radial impeller
- Volute casing (single or double volute)

Overview of single and double volute casings

Size	Volute casing design	
	Single volute	Double volute
200/430	X	-
300/520	X	-
300/600	-	X
300/670	-	X
300/680	-	X
350/500	-	X
350/620	-	X
400/710	-	X
400/770	-	X
500/800	-	X

- Connected by means of studs with covers inserted and flange-mounted on either side
- Horizontal installation
- Double-entry
- Single-stage

### Drive

- Electric motor
- Turbine via gear

### Direction of rotation

- Depends on casing position and nozzle orientation
- Clockwise or anti-clockwise, viewed from the drive

### Suction nozzle

Connection type 1:

- Suction nozzle with flange connection to DIN EN 1092-1, raised face type B
- Suction nozzle with flange connection to ASME Class 300, raised face type RF

Connection type 2:

- Weld end

### Discharge nozzle

Connection type 1:

- Discharge nozzle with flange connection to DIN EN 1092-1, raised face type B
- Discharge nozzle with flange connection to ASME Class 300, raised face type RF

Connection type 2:

- Weld end

### Nozzle position

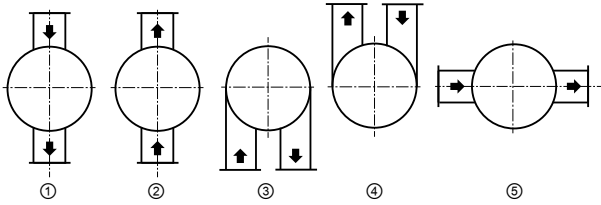

Fig. 1: Possible nozzle positions

- ①: Suction nozzle DN1 on top, discharge nozzle DN2 at bottom
- ②: Suction nozzle DN1 at bottom, discharge nozzle DN2 on top
- ③: Suction nozzle DN1 at bottom, discharge nozzle DN2 at bottom
- ④: Suction nozzle DN1 on top, discharge nozzle DN2 on top
- ⑤: Suction nozzle DN1 horizontal, discharge nozzle DN2 horizontal

### Pump feet arrangement

- Horizontal
- Centreline

### Impeller type

- Closed double-entry radial impeller with multiply curved vanes

### Axial thrust balancing

- Hydraulically by double-entry impeller
- Absorption of residual axial thrust by pivoted segmental thrust bearing

### Bearings

- Forced oil lubricated radial plain bearings and pivoted segmental thrust bearings

### Shaft seal

- Single mechanical seal
  - Uncooled
  - With jacket cooling
  - With mating ring cooling
  - With circulation cooling
- Replaceable shaft sleeve



**Materials**

Part No.	Description	Material
17-6.01/02	Diffuser plate	Chrome steel
102	Volute casing	Cast chrome steel
160	Cover	Carbon steel (plated)
162	Suction cover	Cast chrome steel
210	Shaft	Chrome steel
234	Double-entry impeller	Cast chrome steel
350.01	Bearing housing	Grey cast iron
441	Shaft seal housing	Chrome steel
502.01/02	Casing wear ring	Chrome steel
523	Shaft sleeve	Chrome steel
902.01/02	Stud	Steel which is creep-resistant at elevated temperatures

## Dimensions

Suction nozzle DN1: on top, discharge nozzle DN2: on top or suction nozzle DN1: at bottom, discharge nozzle DN2: at bottom<sup>3)</sup>

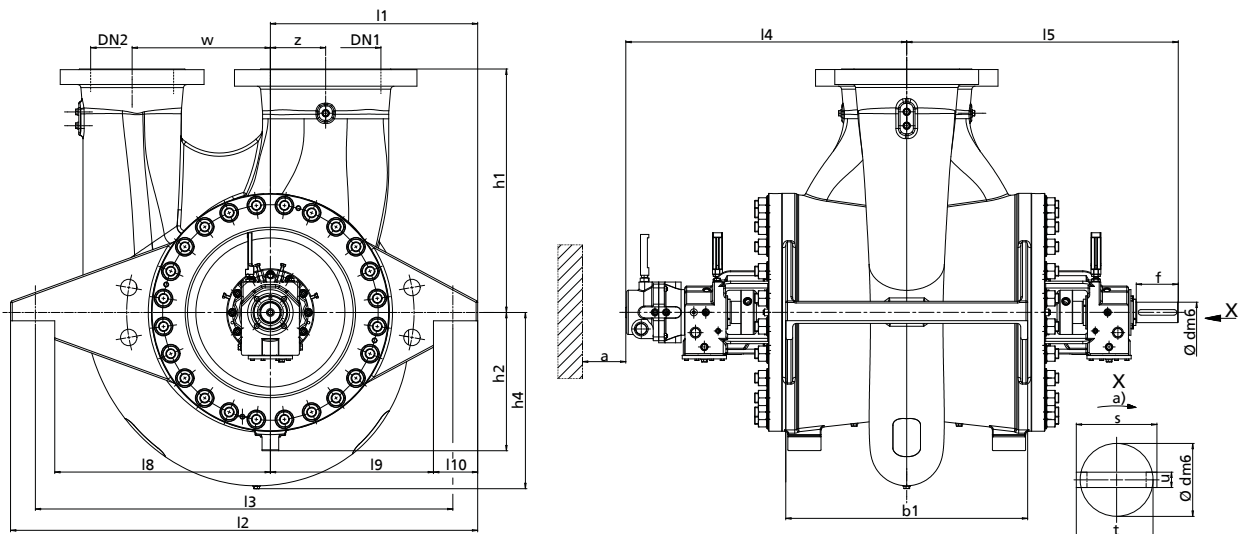

a) Direction of rotation

### Dimensions [mm]

Size	DN1	DN2	l1	l2	l3	l4	l5	l8	l9	l10	h1	h2	h4	w	z
200/430	300	200	575	1150	1050	765	709	475	475	100	475	315	360	275	250
300/520	400	300	770	1540	1420	889	835	640	640	130	700	420	435	366	300
300/600	400	300	630	1430	1290	983	938	660	490	140	816	485	576	425	225
300/670	400	300	920	1840	1630	881	850	735	735	185	800	530	610	360	290
300/680	400	300	750	1690	1510	1016	982	780	590	160	800	500	640	500	200
350/620	640 <sup>4)</sup>	482 <sup>4)</sup>	1020	1940	1760	1016	982	740	840	180	1800	500	610	460	440
400/710	500	400	1055	2110	1910	1037	990	870	870	185	800	570	715	410	360
500/800	640 <sup>4)</sup>	476 <sup>4)</sup>	840	1930	1760	1060	1065	920	670	170	1296	600	900	550	430

### Dimensions [mm]

Size	DN1	DN2	a <sup>5)</sup>	b1	f	d	t	s	u	6)
200/430	300	200	955	434	125	48	51,5	-	14	1
300/520	400	300	1145	560	125	68	72,5	77	20	2
300/600	400	300	1360	780	113,5	74	78,5	83	20	2
300/670	400	300	1170	580	153	74	78,5	83	20	2
300/680	400	300	1445	875	150	74	78,5	83	20	2
350/620	640 <sup>4)</sup>	482 <sup>4)</sup>	1445	920	150	74	78,5	83	20	2
400/710	500	400	1410	780	170	84	89	94	22	2
500/800	640 <sup>4)</sup>	476 <sup>4)</sup>	1600	1020	175	108	114	120	28	2

- 3) Only if the pump foot geometry is symmetric  
 4) Weld end on request  
 5) Clearance required for removal of rotor (from the shaft end)  
 6) Number of keys



Suction nozzle DN1: on top, discharge nozzle DN2: at bottom or suction nozzle DN1: at bottom, discharge nozzle DN2: on top<sup>7)</sup>

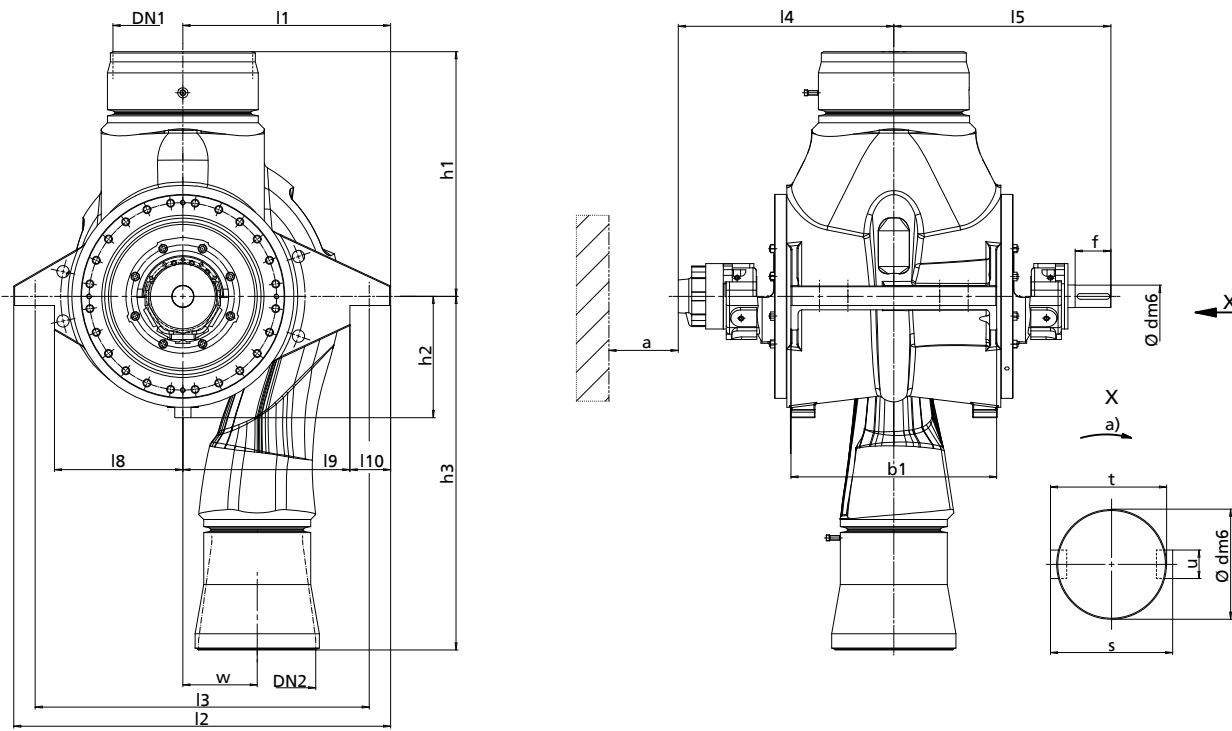

a) Direction of rotation

Dimensions [mm]

Size	DN1	DN2	l1	l2	l3	l4	l5	l8	l9	l10	h1	h2	h3	w	z
300/670	350	350	920	1840	1630	881	850	735	735	185	850	962	960	-	-
300/670	441 <sup>8)</sup>	382 <sup>8)</sup>	920	1840	1630	881	850	735	735	185	1180	-	1370	-	-
300/670	350	300	850	1580	1440	881	850	540	660	190	850	-	800	-	-
300/670	392 <sup>8)</sup>	392 <sup>8)</sup>	920	1840	1630	870	850	735	735	185	1180	870	1470	-	-
300/670	441 <sup>8)</sup>	381 <sup>8)</sup>	920	1840	1630	870	850	735	735	185	1180	870	1370	-	-
400/710	450	450	1000	2000	1790	1037	990	815	815	185	1150	1150	1150	-	-
400/710	486 <sup>8)</sup>	479 <sup>8)</sup>	1000	2000	1790	1037	990	815	815	185	1350	1020	1520	-	-
500/800	686 <sup>8)</sup>	575 <sup>8)</sup>	1020	1850	1640	1055	1065	630	820	200	1200	595	1735	365	-

Dimensions [mm]

Size	DN1	DN2	a <sup>9)</sup>	b1	f	d	t	s	u	<sup>10)</sup>
300/670	350	350	1170	580	153	74	78,5	83	20	2
300/670	441 <sup>8)</sup>	382 <sup>8)</sup>	1170	580	153	74	78,5	83	20	2
300/670	350	300	1170	580	153	74	78,5	83	20	2
300/670	392 <sup>8)</sup>	392 <sup>8)</sup>	1170	745	154	95	100	105	25	2
300/670	441 <sup>8)</sup>	381 <sup>8)</sup>	1170	745	154	95	100	105	25	2
400/710	450	450	1410	780	170	84	89	94	22	2
400/710	486 <sup>8)</sup>	479 <sup>8)</sup>	1410	780	170	84	89	94	22	2
500/800	686 <sup>8)</sup>	575 <sup>8)</sup>	1600	1010	175	108	114	120	28	2

1138.5/02-EN

7) Only if the pump foot geometry is symmetric  
 8) Weld end on request  
 9) Clearance required for removal of rotor (from the shaft end)  
 10) Number of keys

Suction nozzle DN1: horizontal, discharge nozzle DN2: horizontal

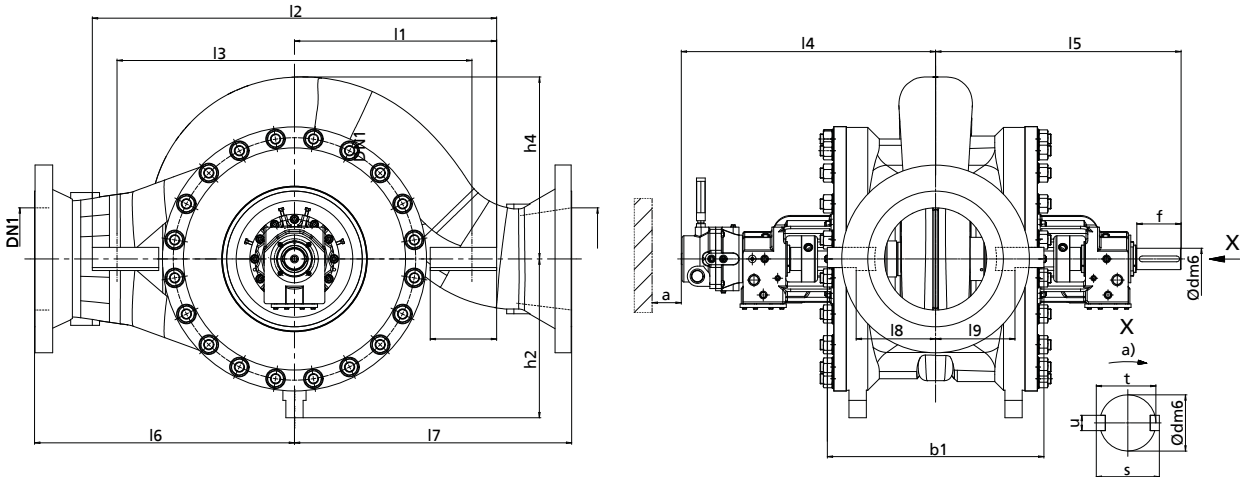

a) Direction of rotation

Dimensions [mm]

Size	DN1	DN2	l1	l2	l3	l4	l5	l6	l7	l8	l9	l10	h1	h2	h3	h4	w	z
300/600	400	302	700	1400	1200	983	937.5	975	960	385	385	275	-	485	-	585	-	-
300/670	400	300	700	1400	1229	881	850	900	960	275	275	220	-	550	-	650	-	-
400/770	480 <sup>11)</sup>	388 <sup>11)</sup>	1000	1900	1780	1123	1065	1200	1300	370	370	170	-	600	-	-840	-	-

Dimensions [mm]

Size	DN1	DN2	a <sup>12)</sup>	b1	f	d	t	s	u	<sup>13)</sup>
300/600	400	302	1360	1000	113,5	74	78,5	83	20	2
300/670	400	300	1170	750	153	74	78,5	83	20	2
400/770	480 <sup>11)</sup>	388 <sup>11)</sup>	1645	1104	152	84	89	94	22	2

Suction nozzle DN1: vertical, discharge nozzle DN2: horizontal<sup>14)</sup>

Dimensions [mm]

Size	DN1	DN2	l1	l2	l3	l4	l5	l6	l7	h1	h2	h3	w	z	a <sup>15)</sup>	b1	f	d	t	s	u	<sup>16)</sup>
200/430	300	200	480	1055	965	765	709	-	680	475	315	-	-	-	955	434	125	48	51,5	-	14	1
350/500	500	350	580	1240	1090	984	936	-	790	720	440	-	-	-	1380	835	130	74	78,5	83	20	2
350/500	398 <sup>17)</sup>	351 <sup>17)</sup>	590	1180	1040	1006	957	-	850	-	480	1050	-	-	1470	1002	130	74	78,5	83	20	2

11) Weld end on request  
 12) Clearance required for removal of rotor (from the shaft end)  
 13) Number of keys  
 14) With this combination please observe the interdependency of direction of rotation and nozzle orientation.  
 15) Clearance required for removal of rotor (from the shaft end)  
 16) Number of keys  
 17) Weld end on request

General assembly drawings with list of components

YNK 300/670, YNK 400/710

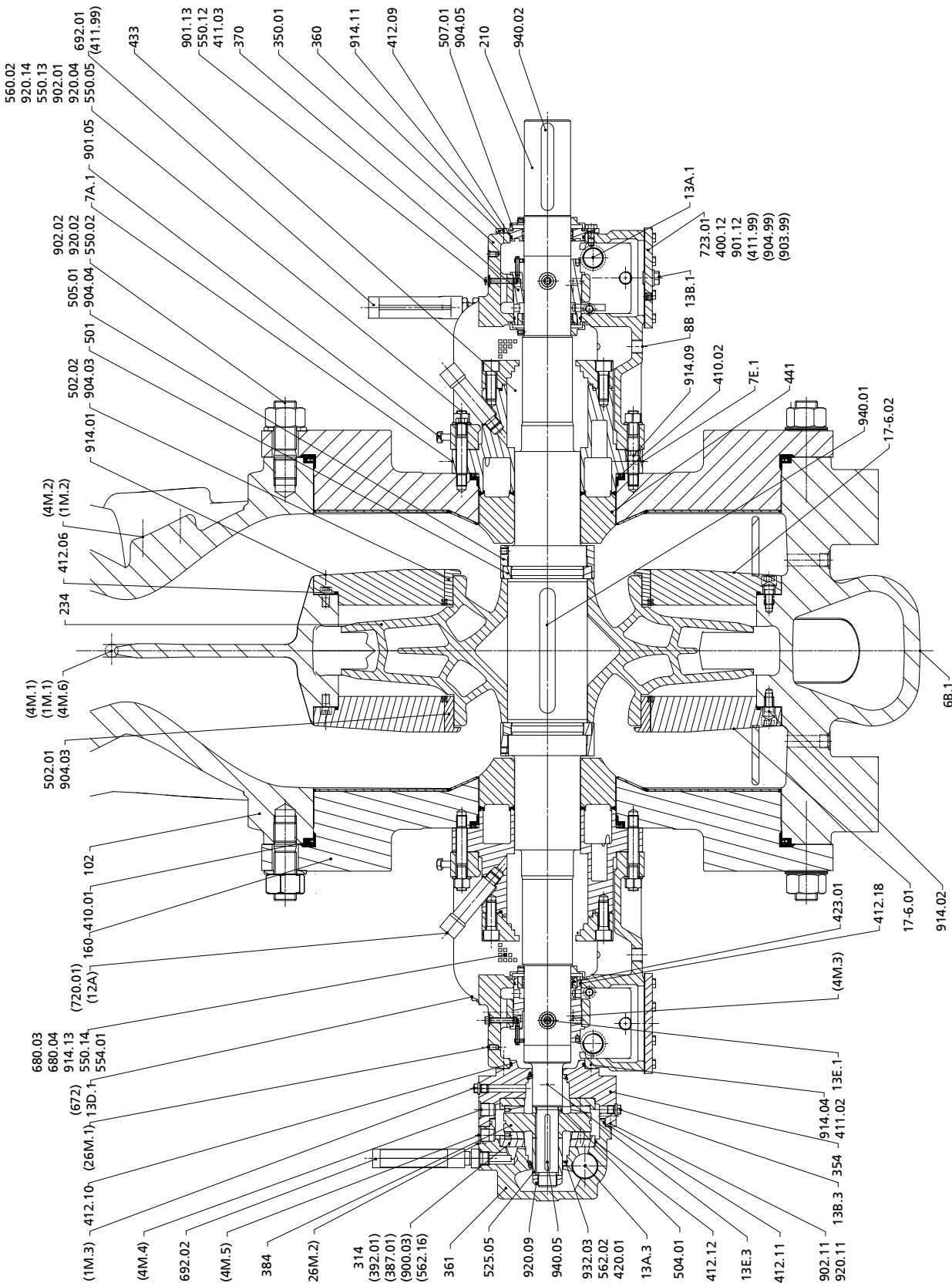

1138.5/02-EN

Fig. 2: General drawing of YNK 300/670, YNK 400/710

List of components

Part No.	Description	Part No.	Description
17-6.01/02	Diffuser plate	502.01/02	Casing wear ring
102	Volute casing	504.01	Spacer ring
160	Cover	505.01	Loose collar
210	Shaft	507.01	Thrower
234	Double-entry impeller	525.05	Spacer sleeve
314	Thrust bearing	550.02/.05/.12/.13/.14	Disc
350.01	Bearing housing	554.01	Washer
354	Thrust bearing housing	560.02	Pin
360	Bearing cover	562.02/.16	Parallel pin
361	Non-drive end bearing cover	672	Vent
370	Bearing shell	680.03/.04	Guard
384	Thrust bearing plate	692.01/02	Temperature measuring instrument
387.01	Thrust bearing segment	720.01	Special pipe part
392.01	Bearing segment carrier	723.01	Flange
400.12	Gasket	900.03	Screw
410.01/02	Profile seal	901.05/.12/.13	Hexagon head bolt
411.02/.03/.99	Joint ring	902.01/.02/.11	Stud
412.06/.09/.10/.11/.12/.18	O-ring	903.99	Screw plug
420.01	Shaft seal ring	904.03/.04/.05/.99	Grub screw
423.01	Labyrinth ring	914.01/.02/.04/.09/.11/.13	Hexagon socket head cap screw
433	Mechanical seal	920.02/.04/.09/.11/.14	Nut
441	Shaft seal housing	932.03	Circlip
501	Segmental ring	940.01/02/05	Key

Connections

Connection	Description
1M.1/.2/.3	Pressure gauge
4M.1/.2/.3/.4/.5/.6	Connection for temperature measuring instruments
6B.1	Drain
7A.1	Cooling liquid outlet
7E.1	Cooling liquid inlet

Connection	Description
8B	Leakage drain
12A	Circulation liquid outlet
13A.1/3	Oil outlet
13B.1/3	Oil drain
13D.1	Oil filling and venting
13E.1/3	Oil inlet
26M.1/2	Vibration measurement

YNK 200/430, YNK 300/520, YNK 300/600, YNK 300/680, YNK 350/500, YNK 400/770, YNK 500/800

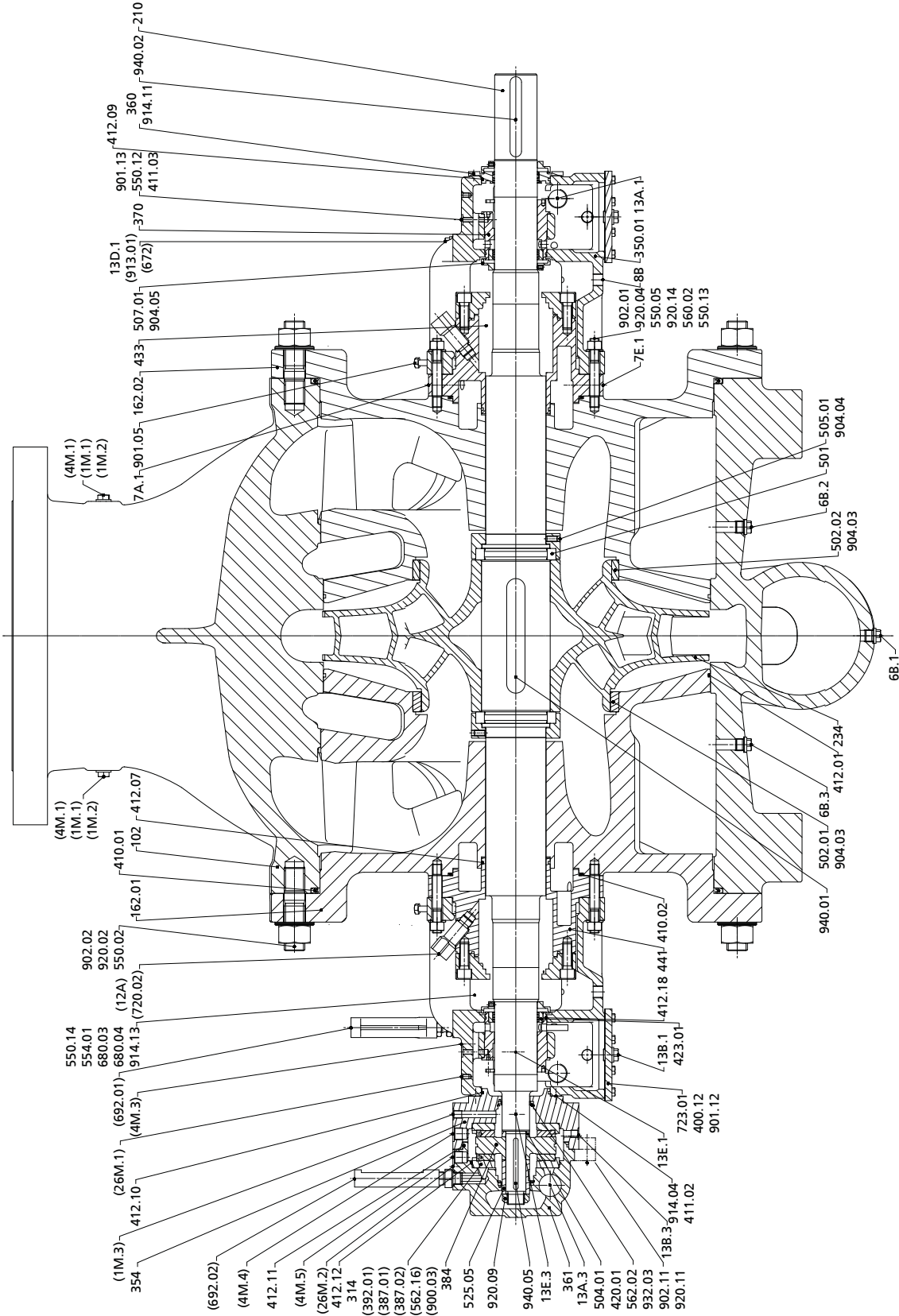

Fig. 3: General drawing of YNK 200/430, YNK 300/520, YNK 300/600, YNK 300/680, YNK 350/500, YNK 400/770, YNK 500/800

1138.5/02-EN

List of components

Part No.	Description	Part No.	Description
102	Volute casing	504.01	Spacer ring
162.01/.02	Suction cover	505.01	Loose collar
210	Shaft	507.01	Thrower
234	Double-entry impeller	525.05	Spacer sleeve
314	Thrust bearing	550.02/.05/.12/.13/.14	Disc
350.01	Bearing housing	554.01	Washer
354	Thrust bearing housing	560.02	Pin
360	Bearing cover	562.02/.16	Parallel pin
361	Non-drive end bearing cover	672	Vent
370	Bearing shell	680.03/.04	Guard
384	Thrust bearing plate	692.01/.02	Temperature measuring instrument
387.01/.02	Thrust bearing segment	720.02	Special pipe part
392.01	Bearing segment carrier	723.01	Flange
400.12	Gasket	900.03	Screw
410.01/.02	Profile seal	901.05/.12/.13	Hexagon head bolt
411.02/.03	Joint ring	902.01/.02/.11	Stud
412.01/.07/.09/.10/.11/.12/.18	O-ring	904.03/.04/.05	Grub screw
420.01	Shaft seal ring	913.01	Vent plug
423.01	Labyrinth ring	914.04/.11/.13	Hexagon socket head cap screw
433	Mechanical seal	920.02/.04/.09/.11/.14	Nut
441	Shaft seal housing	932.03	Circlip
501	Segmental ring	940.01/.02/.05	Key
502.01/.02	Casing wear ring		

Connections

Connection	Description
1M.1/.2/.3	Pressure gauge
4M.1/.3/.4/.5	Connection for temperature measuring instruments
6B.1/.2/.3	Drain
7A.1	Cooling liquid outlet
7E.1	Cooling liquid inlet
8B	Leakage drain
12A	Circulation liquid outlet
13A.1/.3	Oil outlet
13B.1/.3	Oil drain
13D.1	Oil filling and venting
13E.1/.3	Oil inlet
26M.1/.2	Vibration measurement





**KSB SE & Co. KGaA**  
Johann-Klein-Straße 9 • 67227 Frankenthal (Germany)  
Tel. +49 6233 86-0  
[www.ksb.com](http://www.ksb.com)