

Pompe normalisée



Etanorm



Etanorm-R

Automatisation possible avec :

- PumpDrive (MM)
- Hyamaster
- hyatronic

Domaines d'emploi

- Adduction d'eau
- Protection-incendie
- Arrosage
- Irrigation
- Assèchement
- Chauffage
- Climatisation
- Eau potable
- Eau industrielle
- Eau surchauffée
- Eau de refroidissement
- Eau de piscine
- Eau de mer
- Eau incendie
- Eau saumâtre
- Condensat
- Saumure
- Huiles
- Détergents

Liquide pompé

Liquides purs n'attaquant les matériaux de construction ni chimiquement ni mécaniquement.

Caractéristiques de service

Q jusqu'à 660 m³/h, 183 l/s
H jusqu'à 102 m
t -30 °C jusqu'à +140 °C
p₂ jusqu'à 16 bar ¹⁾

¹⁾ voir limites de pression/température, page 5

Construction

Pompe horizontale à volute, monoétagée, performances et dimensions principales suivant la norme EN 733, avec support de palier, en construction process.

Arbre équipé au niveau de la garniture d'étanchéité d'arbre d'une chemise d'arbre/chemise de protection d'arbre remplaçable.

Volute et roue avec bagues d'usure remplaçables. Volute avec pieds de pompe attenants.

Paliers

Roulement à billes à gorge profonde, lubrifié à la graisse.

Etanchéité d'arbre

par garniture mécanique selon DIN 24 960 ou garniture de presse-étoupe.

Certification

Gestion de la qualité certifiée suivant ISO 9001.

Désignation

EN-(R) 40 - 160 [43 (6238) G 10^{*)}

Gamme Etanorm _____
Type de pompe, p. ex. _____
Diamètre effectif de roue - 100 mm _____
p.ex. 143 mm = (roues rognées au tour de façon oblique) _____
p.ex. diam. effectif 162/138 mm = _____
Matériau du corps, p. ex. JL 1040 ²⁾ _____
Etanchéité d'arbre, p.ex. garniture mécanique Q₁ Q₁ X4GG _____

²⁾ selon EN 1561 = GJL-250

^{*)} uniquement valable pour Etanorm

Accessoires

Entraînement

Par moteur triphasé KSB à rotor en court-circuit, ventilé, conforme à C.I.E.

Bobinage: jusqu'à 2,2 kW 220-240 V/380-420 V
à partir de 3 kW 380-420 V/660-725 V

Construction: IMB 3

Protection: IP 55

Classe d'isolement: F avec sonde de température :
3 thermistances

Type de service: Service permanent S1

ou

par moteur triphasé à rotor en court-circuit, ventilé tel que décrit ci-dessus, mais de marque ouest-européenne selon notre choix.

Accouplement

Accouplement élastique avec/sans pièce d'espacement.

Protection contre les contacts fortuits

Protecteur d'accouplement selon EN 294.

Socle

en acier profilé/tôle d'acier chanfreiné
socle commun pour pompe et moteur
en exécution rigide sans risque de gauchissement

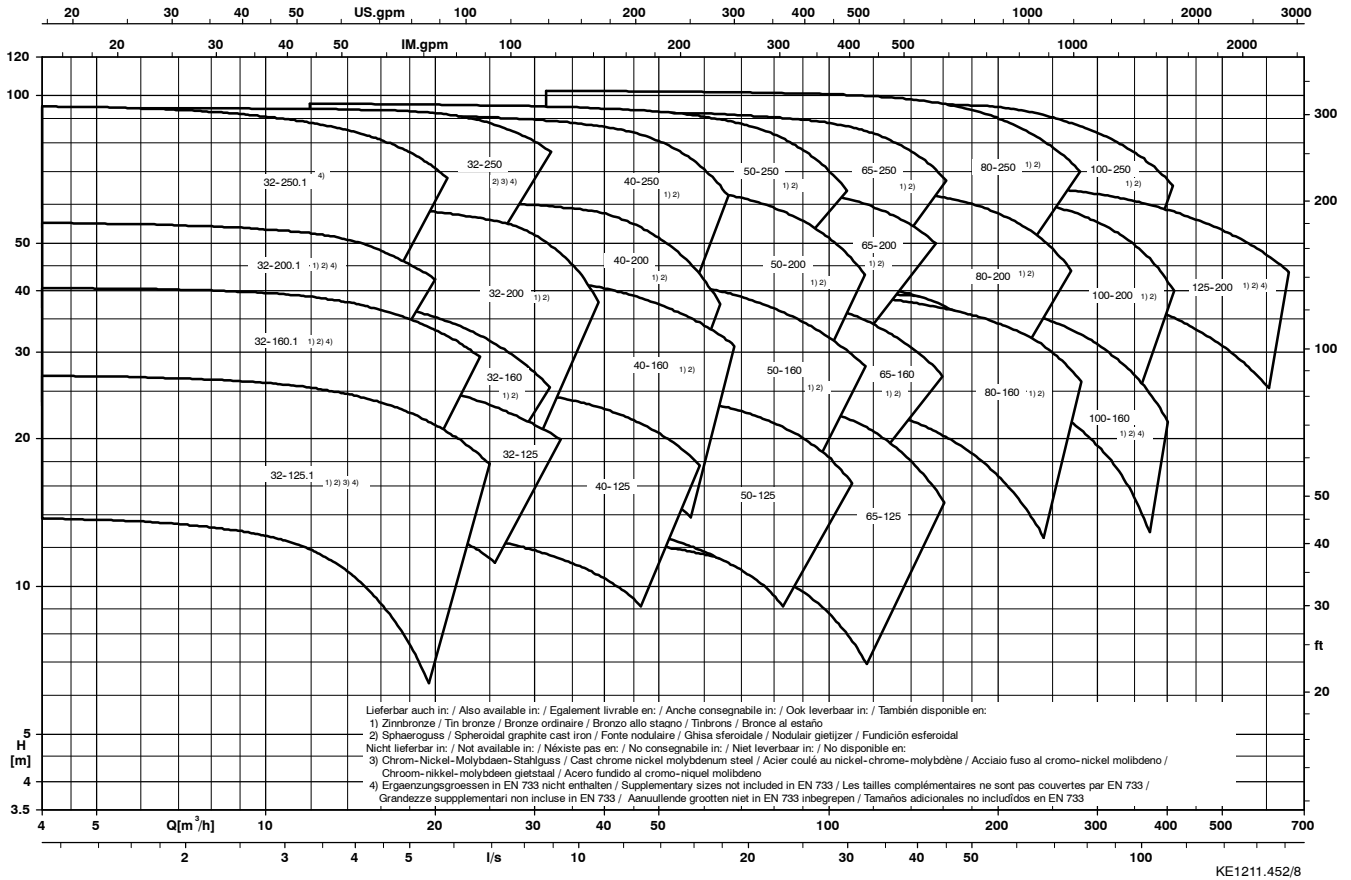
Information produit selon le règlement 547/2012 (pour pompes à eau ayant une puissance maximale à l'arbre de 150 kW) portant application de la directive 2009/125/CE « écoconception »

- Indice de rendement minimum : cf. fiche de spécifications.
- Le critère de référence correspondant aux pompes à eau les plus efficaces est $MEI \geq 0,70$.
- Année de construction : cf. fiche de spécifications.
- Nom du fabricant ou marque de fabrique, n° d'enregistrement officiel et lieu de fabrication : cf. fiche de spécifications ou la documentation fournie.
- Information sur le type et la taille du produit : cf. fiche de spécifications.
- Rendement hydraulique de la pompe (%) avec diamètre de roue corrigé : cf. fiche de spécifications.
- Courbiers de la pompe, y compris la courbe d'efficacité : cf. la courbe documentée.
- Le rendement d'une pompe dont la roue a été corrigée est généralement plus faible que celui d'une pompe dont le diamètre de roue est maximal. La correction de la roue permet d'adapter la pompe à un certain point de fonctionnement et, par là-même, de réduire la consommation d'énergie. L'indice de rendement minimum (MEI) est fondé sur le diamètre maximal de la roue.
- Le fonctionnement de cette pompe à eau à différents points de fonctionnement peut être plus efficace et plus rentable si elle est par exemple commandée par un régulateur de vitesse qui adapte le fonctionnement de la pompe au système.
- Informations relatives au démontage, au recyclage ou à l'élimination du produit en fin de vie : cf. la notice de service / de montage.
- Les informations relatives au rendement de référence ou au graphique du rendement de référence de la pompe pour un $MEI = 0,7$ (0,4) sur la base du modèle indiqué sur l'illustration sont disponibles à l'adresse suivante : [http:// www.europump.org/efficiencycharts](http://www.europump.org/efficiencycharts).

Réseau

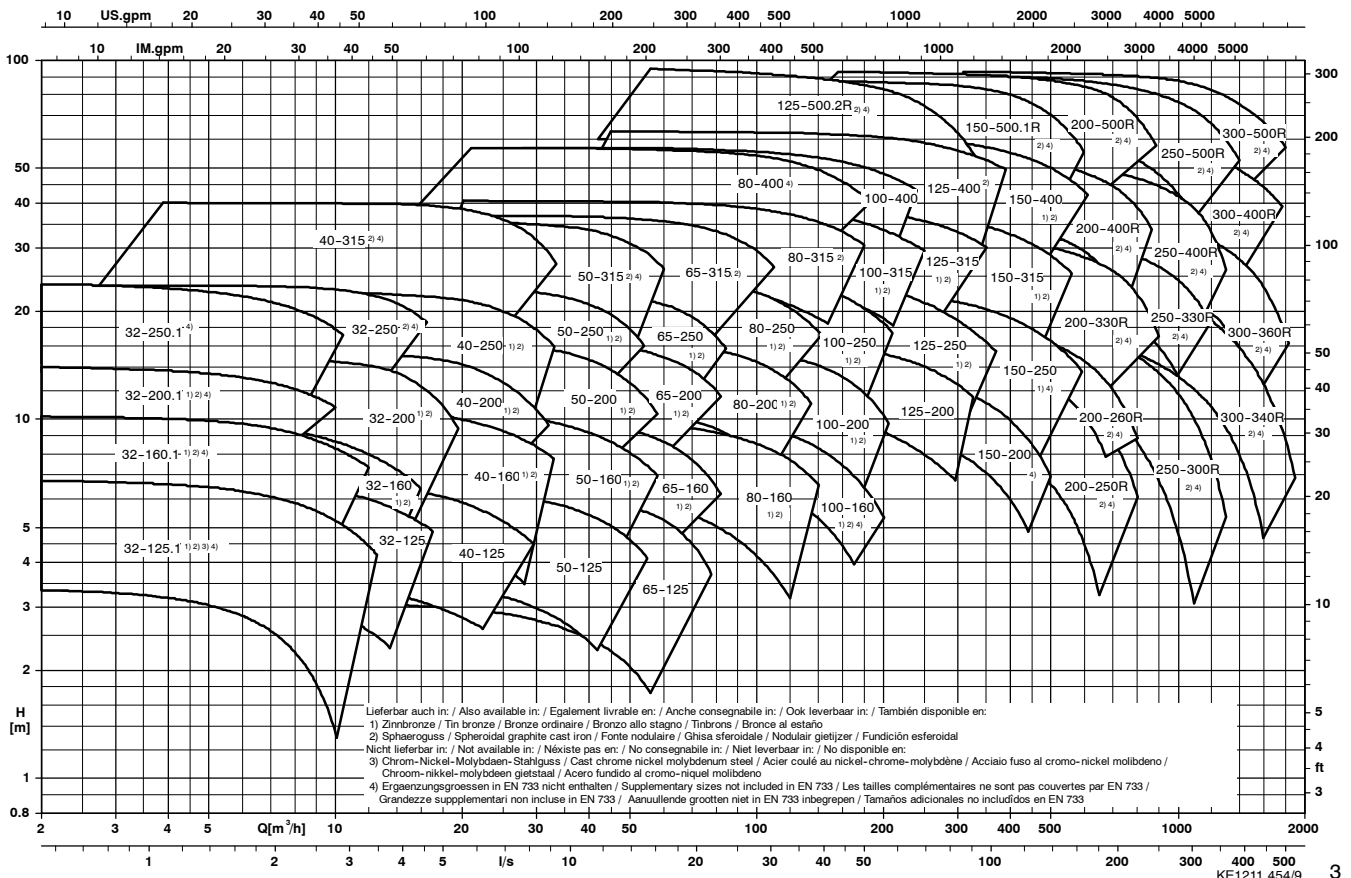
Etanorm

n = 2900 1/min



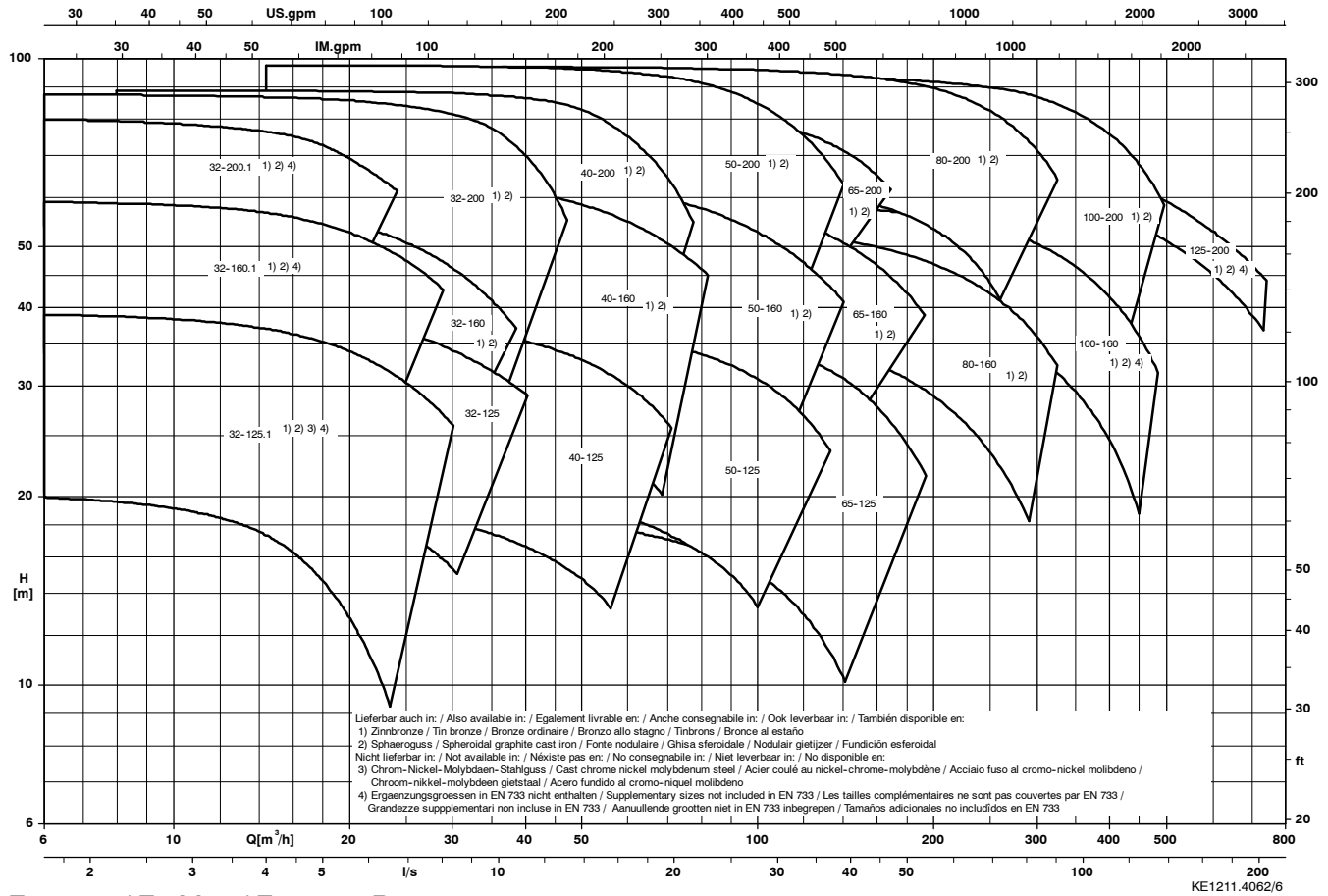
Etanorm / Etanorm-R

n = 1450 1/min



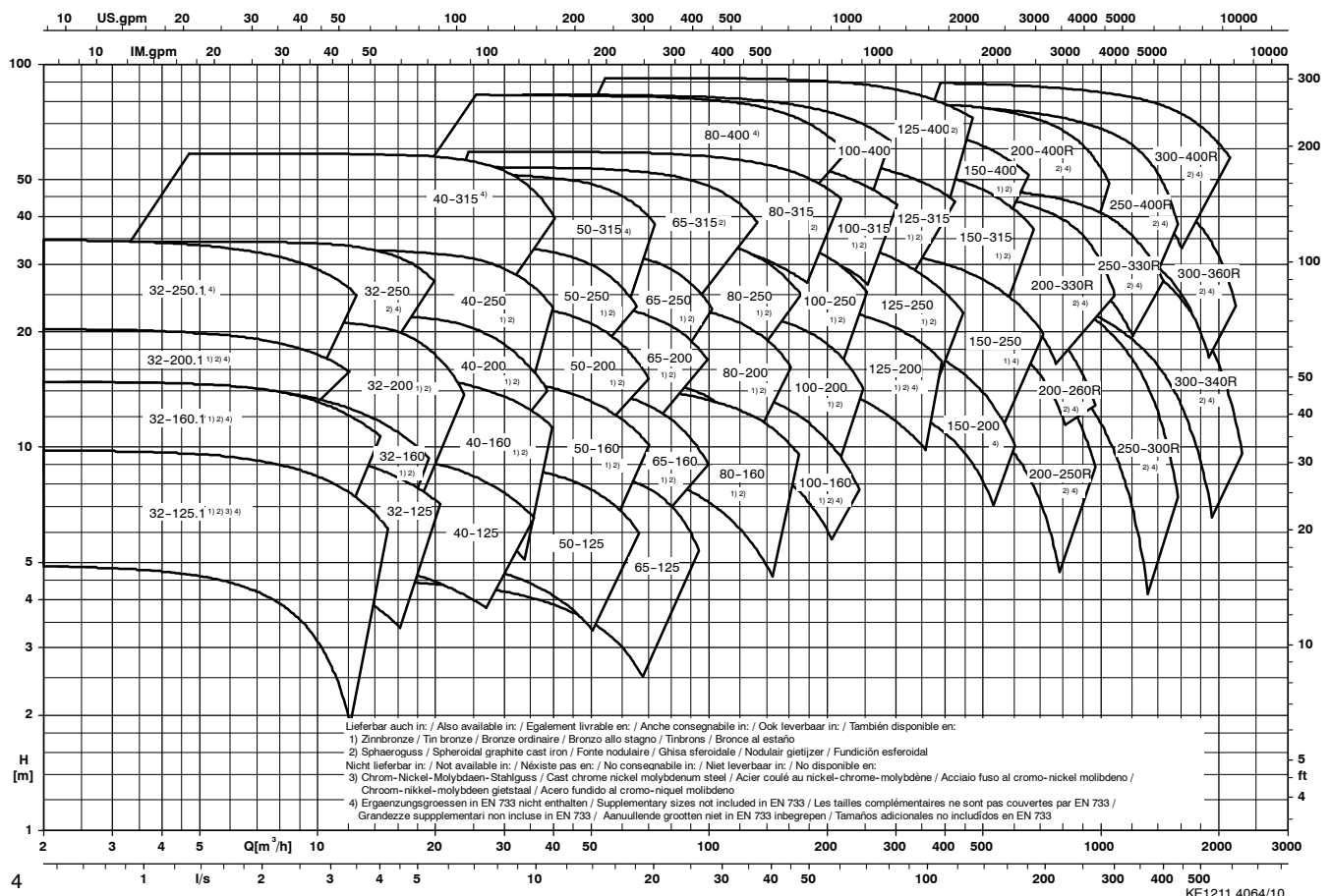
Etanorm

n = 3500 1/min



Etanorm / Etabloc / Etanorm-R

n = 1750 1/min



Matériaux

	Etanorm G / Etanorm-RG	Etanorm-R GC1	Etanorm M	Etanorm-RM	Etanorm B
Volute	Fonte grise JL 1040 ¹⁾		Fonte grise JL 1040 ¹⁾		Bronze ordinaire CC 480 K-GS ³⁾
Fond de refoulement	Fonte grise JL 1040 ¹⁾		Fonte grise JL 1040 ¹⁾		Bronze ordinaire CC 480 K-GS ³⁾
Roue	Fonte grise JL 1040 ¹⁾	1.4408	Bronze ordinaire CC 480 K-GS ³⁾		Bronze ordinaire CC 480 K-GS ³⁾
Bague d'usure	Fonte grise GG		Fonte grise/ Bronze au plomb GG/CG 495 K-GS ³⁾		Bronze au plomb CG 495 K-GS ³⁾
Arbre	Acier de traitement C45		Acier de traitement C45		Acier au chrome-nickel-molybdène 1.4462
Chemise d'arbre	Acier au chrome-nickel-molybdène 1.4571	1.4122	Acier au chrome-nickel-molybdène 1.4571	1.4122	Acier au chrome-nickel-molybdène 1.4571
Chemise de protection d'arbre	Acier au chrome-molybdène 1.4122		Acier au chrome-molybdène 1.4122		Chrom-Nickel-Molybdän-Stahl 1.4571
Support de palier	Fonte grise JL 1040 ¹⁾		Fonte grise JL 1040 ¹⁾		Fonte grise JL 1040 ¹⁾

	Etanorm S	Etanorm-RS	Etanorm C
Volute	Fonte nodulaire JS 1025 ²⁾		Acier coulé au chrome-nickel-molybdène 1.4408
Fond de refoulement	Fonte nodulaire JS 1025 ²⁾		Acier coulé au chrome-nickel-molybdène 1.4408
Roue	Fonte grise JL 1040 ¹⁾		Acier coulé au chrome-nickel-molybdène 1.4408
Bague d'usure	Fonte grise GG		Acier coulé au chrome-nickel-molybdène 1.4408
Arbre	Acier de traitement C45		Acier au chrome-nickel-molybdène 1.4462
Chemise d'arbre	Acier au chrome-nickel-molybdène 1.4571	1.4122	Acier au chrome-nickel-molybdène 1.4571
Chemise de protection d'arbre	Acier au chrome-molybdène 1.4122		Acier au chrome-nickel-molybdène 1.4571
Support de palier	Fonte grise JL 1040 ¹⁾		Fonte grise JL 1040 ¹⁾

- 1) selon EN 1561 = GJL-250
 2) selon EN 1563 = GJS-400-18-LT
 3) selon EN 1982

Les avantages d'un seul coup d'oeil

Grand choix de matériaux: fonte grise, bronze ordinaire, fonte à graphite sphéroïdal, acier coulé au chrome-nickel-molybdène

Fourreau de surpression conçu pour 16 bar et une haute fiabilité de service

Dimensions de raccordement et performances selon EN 733 (Etanorm)

Bague d'usure permettant un entretien facile

Géométrie d'entrée conçue pour une capacité d'aspiration optimale (NPSH) et le meilleur comportement en phase de cavitation

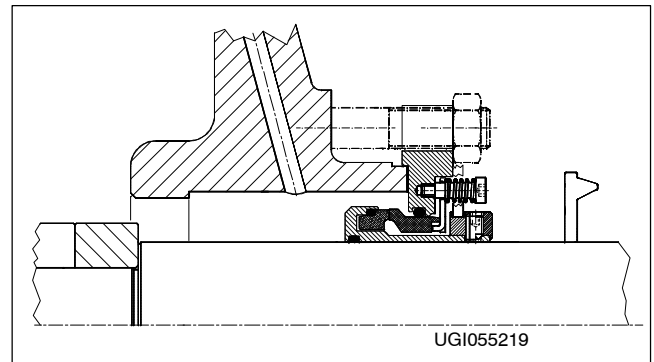
Roue à profil optimisé, rendements hydrauliques excellents et graduation fine de la grille des caractéristiques Q-H

Garniture mécanique ou garniture de presse-étoupe, non refroidie

Construction process, permettant le démontage de la pompe sans débrider le corps de pompe

Roulements à billes à gorge profonde, robustes, protégés par des bagues V (Etanorm) contre l'encrassement

Chemise d'arbre prévenant toute usure de l'arbre

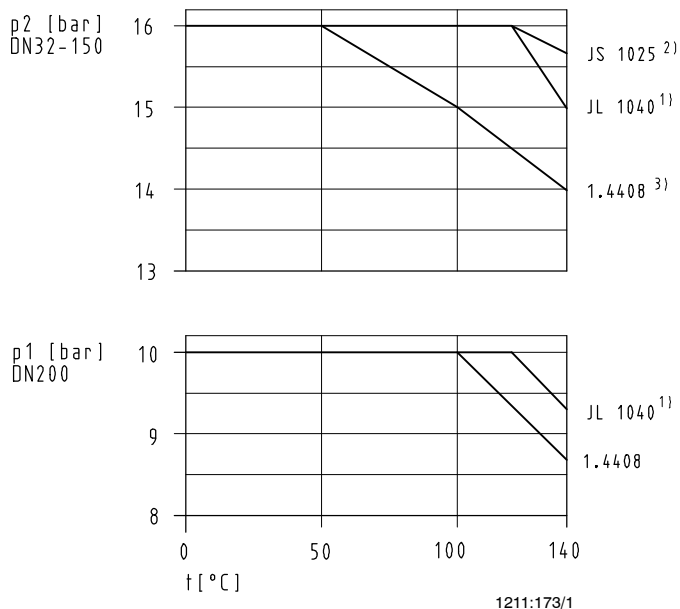
Variante: Etanorm-R


1211:132/4

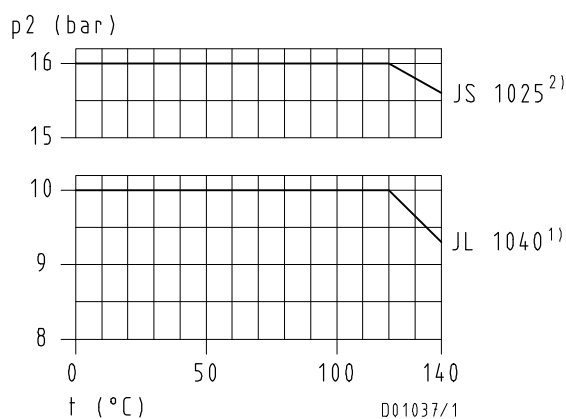
Limites de pression et de température

Etanorm/ Etanorm-R	Température du li- quide pompé 1)4)	Pression à la sortie p ₂ 2)	Pression d'épreuve	
			Etanorm	Etanorm-R
G	-30 °C jusqu'à +140 °C	5)	jusqu'à 21 bar	jusqu'à 15 bar
M	-30 °C jusqu'à +140 °C		jusqu'à 21 bar	jusqu'à 15 bar
S	-30 °C jusqu'à +140 °C		jusqu'à 25 bar	jusqu'à 24 bar
B	-30 °C jusqu'à +140 °C	10 bar	jusqu'à 13 bar	--
C	-30 °C jusqu'à +140 °C	5)	jusqu'à 21 bar	--

- 1) Pour le transport d'eau surchauffée (installations selon DIN 4752, paragraphe 4.5) observer les limites d'application
- 2) La somme de la pression d'entrée et de la hauteur manométrique au point de débit nul ne doit pas dépasser les valeurs figurant dans le diagramme ci-après
- 3) Les volutes sont soumises à un essai d'étanchéité à l'eau selon AN 1897/75-03 D00
- 4) Pour les liquides pompés > 140 °C prévoir une pompe Etanorm SYN
- 5) voir diagramme ci-après

Limites de pression / température pour brides selon ISO 7005-1 et EN 1092-2

Etanorm-R

toutes tailles



- 1) selon EN 1561 = GJL-250
- 2) selon EN 1563 = GJS-400-18-LT
- 3) seulement DN 65-150; DN 32-50 16 bar

Tailles de pompe en fonction des matériaux

Tailles	Etanorm				
	G	M	S	B	C
32-125.1	X	X	X	X	X
32-160.1	X	X	X	X	X
32-200.1	X	X	X	X	X
32-250.1	X	X	-	-	X
32-125	X	X	-	-	X
32-160	X	X	X	X	X
32-200	X	X	X	X	X
32-250	X	X	X	-	X
40-125	X	X	-	-	X
40-160	X	X	X	X	X
40-200	X	X	X	X	X
40-250	X	X	X	X	X
40-315	X	X	X	-	X
50-125	X	X	-	-	X
50-160	X	X	X	X	X
50-200	X	X	X	X	X
50-250	X	X	X	X	X
50-315	X	X	X	-	X
65-125	X	X	-	-	X
65-160	X	X	X	X	X
65-200	X	X	X	X	X
65-250	X	X	X	X	X
65-315	X	X	X	-	X
80-160	X	X	X	X	X
80-200	X	X	X	X	X
80-250	X	X	X	X	X
80-315	X	X	X	-	X
80-400	X	X	-	-	X
100-160	X	X	X	X	X
100-200	X	X	X	X	X
100-250	X	X	X	X	X
100-315	X	X	X	X	X
100-400	X	X	-	-	X
125-200	X	X	X	X	X
125-250	X	X	X	X	X
125-315	X	X	X	X	X
125-400	X	X	X	-	X
150-200	X	X	-	-	X
150-250	X	X	-	X	X
150-315	X	X	X	X	X
150-400	X	X	X	X	X

Tailles	Etanorm-R			
	G	GC1	M	S
125-500/2	X	X	X	X
150-500.1	X	X	X	X
200-250	X	X	X	X
200-260	X	X	X	X
200-330	X	X	X	X
200-400	X	X	X	X
200-500	X	X	X	X
250-300	X	X	X	X
250-330	X	X	X	X
250-400	X	X	X	X
250-500	X	X	X	X
300-340	X	X	X	X
300-360	X	X	X	X
300-400	X	X	X	X
300-500	X	X	X	X

Etanorm

Liquide pompé	Limites d'application	Matériaux ⁹⁾					Garniture d'étanchéité d'arbre						Code d'exécution	Observations		
		Corps/roue					Garniture de presse-étoupe	Garniture mécanique							Garniture de presse-étoupe Nb:p1 ≤ 0,5 bar Nb:p1 > 0,5 bar	Garniture mécanique
		fonte grise/ fonte grise	fonte grise/ bronze ordinaire	fonte GS	bronze ordinaire	bronze ordinaire / acier coulé CrNiMo / acier coulé CrNiMo		1	3	6	9	10				
G	M	S	B	C	RT-P	graphite pur	U3BEGG 4)	U3U3X4GG	Q1O1X4GG	BQ1EGG	Q1Q1MMGG					
Eau																
Eau de barrage ¹⁾	t ≤ 60 °C ⁷⁾ ; p ≤ 10 bar		X				X			X				M1	M10	En présence de matières solides nous consulter s.v.p.
Eau brute ¹⁾	t ≤ 60 °C ⁷⁾ ; p ≤ 10 bar	X					X			X				G1	G10	
Eau de chauffage ²⁾	t ≤ 120 °C; p ≤ 10 bar	X					X				X			G1	G11	Pour utilisation comme pompe de circulation suivant la norme DIN 4752; p maxi. ≤ 10 bar. Pour exigence matériau tenace: "S"
Eau de chauffage ²⁾	t ≤ 140 °C; p ≤ 16 bar	X					X	X						G3	G6	
Eau de chauffage ²⁾	t ≤ 110 °C; p ≤ 10 bar	X					X			X				G1	G10	
Eau de mer ³⁾	t ≤ 25 °C; p ≤ 10 bar				X		X			X				B1	B10	Possibilité d'acier coulé au CrNiMo
Eau de piscine (eau douce) ¹⁾	t ≤ 60 °C; p ≤ 10 bar	X					X			X				G1	G10	Egaleme nt pour exigence suivant DIN 19 643
Eau de piscine (eau de mer) ³⁾	t ≤ 40 °C; p ≤ 10 bar				X		X			X				B1	B10	Possibilité d'acier coulé au CrNiMo pour t ≤ +25 °C
Eau de refroidissement ¹⁾ (sans antigels)	t ≥ 60 °C ⁷⁾ ; p ≤ 10 bar	X					X			X				G1	G10	Circulation ouverte; prévoir M1/M10
Eau de refroidissement valeur pH ≥ 7,5 (avec antigels) ⁵⁾	t ≥ -30 °C; t ≤ 110 °C; p ≤ 10 bar	X					X			X				G1	G11	Circulation ouverte; prévoir M1/M11
Eau entièrement dessalée	t ≤ 120 °C; p ≤ 10 bar					X	X				X			C1	C11	Exigences de pureté ne peuvent pas être satisfaites
Eau entièrement dessalée en tant qu'eau de chaudière ²⁾	t ≤ 120 °C; p ≤ 10 bar	X					X				X			G1	G11	
Eau-incendie ¹⁾	t ≤ 60 °C ⁷⁾ ; p ≤ 10 bar		X				X			X				M1	M10	Pour livraison suivant prescription VdS nous consulter s.v.p.
Eau légèrement chargée ¹⁾	t ≤ 60 °C ⁷⁾ ; p ≤ 10 bar	X					X			X				G1	G10	
Eau partiellement dessalée ²⁾	t ≤ 120 °C; p ≤ 10 bar	X					X			X				G1	G11	
Eau potable ¹⁾	t ≤ 60 °C ⁸⁾ ; p ≤ 10 bar		X				X			X				M1	M11	
Eau pure ⁶⁾	t ≤ 60 °C ⁸⁾ ; p ≤ 10 bar	X					X			X				G1	G11	
Eau saumâtre ³⁾	t ≤ 25 °C; p ≤ 10 bar				X		X			X				B1	B10	Possibilité d'acier coulé au CrNiMo
Condensat ²⁾	t ≤ 120 °C; p ≤ 10 bar	X					X			X				G1	G11	
Condensat non conditionné ²⁾	t ≤ 120 °C; p ≤ 10 bar					X	X				X			C1	C11	
Détergents																
Lessives pour rince-bouteilles	t ≤ 90 °C; p ≤ 10 bar	X					X							G1	G7	Q, Q, EGG
Huiles, émulsions																
Carburant Diesel fuel EL	t ≤ 60 °C; p ≤ 10 bar		X							X				S10		Fonte grise possible, si aucune prescription ne doit être respectée
Emulsion de coupe/de rectification	t ≤ 60 °C; p ≤ 10 bar	X							X					G1	G9	
Emulsion huile-eau	t ≤ 60 °C; p ≤ 10 bar	X								X				G1	G9	
Huile de lubrification, huile à turbine ne s'applique pas aux huiles SF-D (peu inflammables)	t ≤ 80 °C; p ≤ 10 bar			X							X				S10	Pour exigence "sans" couche de fond intérieure, nous consulter s.v.p. Fonte grise possible, si aucune prescription ne doit être respectée
Réfrigérants, saumures de refroidissement																
Eau avec antigels Valeur pH ≥ 7,5 ^{1), 5)}	t ≥ -30 °C; t ≤ 110 °C; p ≤ 10 bar	X					X			X				G1	G11	
Saumure de refroidissement; inorganique Valeur pH > 7,5; inhibée	t ≥ -30 °C; t ≤ 25 °C; p ≤ 10 bar	X					X			X				G1	G11	
Brasserie																
Trempe de bière	t ≤ 100 °C; p ≤ 10 bar	X										X			G12	S'il y a risque de marche à sec dû à une vidange excessive du réservoir, utiliser une pompe Etanorm avec garniture double disposée en tandem.
Moût de bière	t ≤ 100 °C; p ≤ 10 bar	X										X			G12	

- Critères généraux d'évaluation dans le cas d'une analyse d'eau: valeur pH ≥ 7; teneur en chlorures (Cl) ≤ 250 mg/kg. Chlore (Cl₂) ≤ 0,6 mg/kg.
- Préparation svt. VdTUV 1466; et il faut que: O₂ ≤ 0,02 mg/l
- Pour les composants en bronze s'applique: ammoniac (NH₃) ≤ 5 mg/kg, exempt d'acides sulfhydriques (H₂S); mais dans ce cas, la restriction de la teneur en Cl peut être supprimée. En cas de non-observation des valeurs limites, nous consulter s.v.p.
- Uniquement pour unités d'arbre 25 et 35; unité d'arbre 55 = AQ1EGG Attribution des unités d'arbre voir page 15
- Antigels sur la base d'éthylène-glycol avec inhibiteurs. Teneur: > 20% jusqu'à 50% (p.ex. Antifrogen N)
- Pas d'eau extra-pure! Conductibilité à 25 °C: ≤ 800 µS/cm, non-corrosive et neutre.
- Garniture mécanique admissible si t ≤ 110 °C
- Garniture mécanique admissible si t ≤ 120 °C
- Pour le tableau des matériaux en fonction des tailles voir page 3

Exemple de sélection:

Données: Eau pure 15 °C; Q = 60 m³/h; H = 80 m

Solution: Etanorm G 50 - 250 G 1 (ou G 11)

Variante de matériau (suivant tableau ci-dessus) _____

Type de pompe (suivant courbe caractéristique 2900 1/min) _____

Code d'exécution (suivant tableau ci-dessus) _____

Puissance d'entraînement requise 22 kW

Etanorm-R

Liquide pompé	Limites d'application	Matériaux Corps roue			Garniture d'étanchéité d'arbre		Code d'exécution	
		G	M	S	Garniture de presse-étoupe 1	Garniture mécanique 4	Garniture de presse-étoupe Na: P ₁ ≤ 0,5 bar Nb: P ₁ > 0,5 bar	Garniture mécanique
Eau								
Condensat ²⁾	t ≤ 120 °C; p ≤ 10 bar	X			X		G1	nous consulter.
Eau brute (irrigation) ¹⁾	t ≤ 60 °C; p ≤ 10 bar	X				X	-	G4
Eau brute (applications industrielles) ¹⁾	t ≤ 60 °C; p ≤ 10 bar	X			X	X	G1	G4
Eau de barrage ¹⁾	t ≤ 60 °C; p ≤ 10 bar		X			X	-	M4
Eau de chauffage ²⁾	t ≤ 120 °C; p ≤ 10 bar	X			X	X	G1	G4
Eau de chauffage ²⁾	t ≤ 140 °C; p ≤ 16 bar			X	X	X	S1	S4
Eau de chauffage ²⁾	t ≤ 110 °C; p ≤ 10 bar	X			X	X	G1	G4
Eau de piscine (eau douce) ¹⁾	t ≤ 60 °C; p ≤ 10 bar	X			X	X	G1	G4
Eau de refroidissement ¹⁾ (sans antigels)	t ≤ 60 °C; p ≤ 10 bar	X			X	X	G1	G4
Eau de refroidissement valeur pH ≥ 7,5 (avec antigels) ⁵⁾	t ≥ -30 °C; p ≤ 10 bar t ≤ 110 °C	X			X	X	G1	G4
Eau de service	t ≤ 60 °C; p ≤ 10 bar	X				X	-	G4
Eau entièrement dessalée (VE-) eau en tant qu' eau de chaudière ²⁾	t ≤ 120 °C; p ≤ 10 bar	X			X	X	G1	G4
Eau légèrement chargée ¹⁾	t ≤ 60 °C; p ≤ 10 bar	X			X	X	G1	G4
Eau partiellement dessalée ²⁾	t ≤ 120 °C; p ≤ 10 bar	X			X		G1	nous consulter.
Eau potable ¹⁾	t ≤ 60 °C; p ≤ 10 bar		X		X	X	M1	M4
Eau pure ⁴⁾	t ≤ 25 °C; p ≤ 10 bar	X			X	X	G1	G4
Eau-incendie ¹⁾	t ≤ 60 °C; p ≤ 10 bar		X			X	-	M4
Réfrigérants, saumures de refroidissement								
Eau avec antigels Valeur pH ≥ 7,5 ^{1), 3)}	t ≥ -30 °C; p ≤ 10 bar t ≤ 110 °C	X			X	X	G1	G4
Saumure de refroidissement; anorganique Valeur pH > 7,5; inhibée	t ≥ -30 °C; p ≤ 10 bar t ≤ 25 °C	X			X	X	G1	G4
Huiles, émulsions								
Carburant, fuel EL	t ≤ 60 °C; p ≤ 10 bar			X		X		S4
Emulsion de coupe/de rectification	t ≤ 60 °C; p ≤ 10 bar	X				X		G4
Emulsion huile-eau	t ≤ 60 °C; p ≤ 10 bar	X			X	X	G1	G4
Huile de lubrification, huile à turbine ne s'applique pas aux huiles SF-D (peu inflammables)	t ≤ 80 °C; p ≤ 10 bar			X		X		S4
Détergents								
Lessives pour rince-bouteilles	t ≤ 90 °C; p ≤ 10 bar	X			X		G1	
Brasserie								
Moût de bière	t ≤ 100 °C; p ≤ 10 bar	X			X	X		G4
Trempe de bière	t ≤ 100 °C; p ≤ 10 bar	X				X		G4

1) Critères généraux d'évaluation dans le cas d'une analyse d'eau: valeur pH ≥ 7; teneur en chlorures (Cl) ≤ 250 mg/kg. Chlore (Cl₂) ≤ 0,6 mg/kg.

2) Préparation svt. VdTUV 1466; et il faut que: O₂ ≤ 0,02 mg/l

3) Antigels sur la base d'éthylène-glycol avec inhibiteurs. Teneur: > 20% jusqu'à 50 % (p.ex. Antifrogen N)

4) Pas d'eau extra-pure! Conductibilité à 25°C: ≤ 800 µS/cm, non-corrosive et neutre.

5) Antigels sur la base d'éthylène-glycol avec inhibiteurs. Teneur: > 20% jusqu'à 50 % (p.ex. Antifrogen N)

Etanorm 32-125.1 - 32-250.1

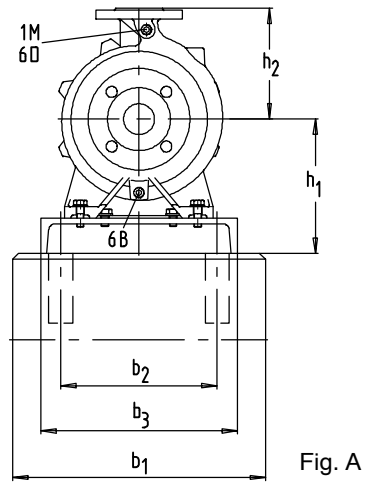
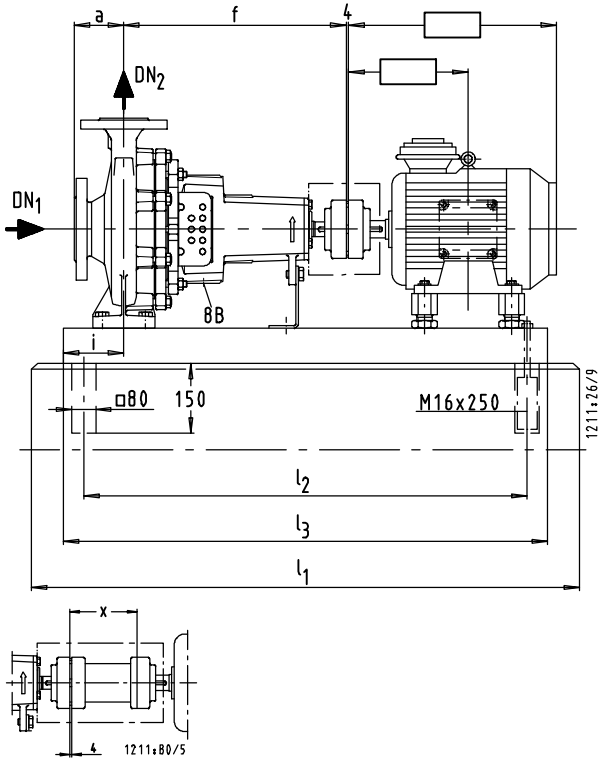
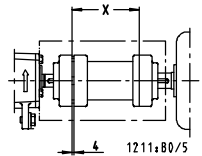
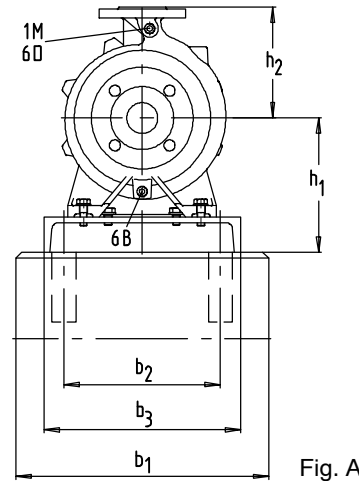
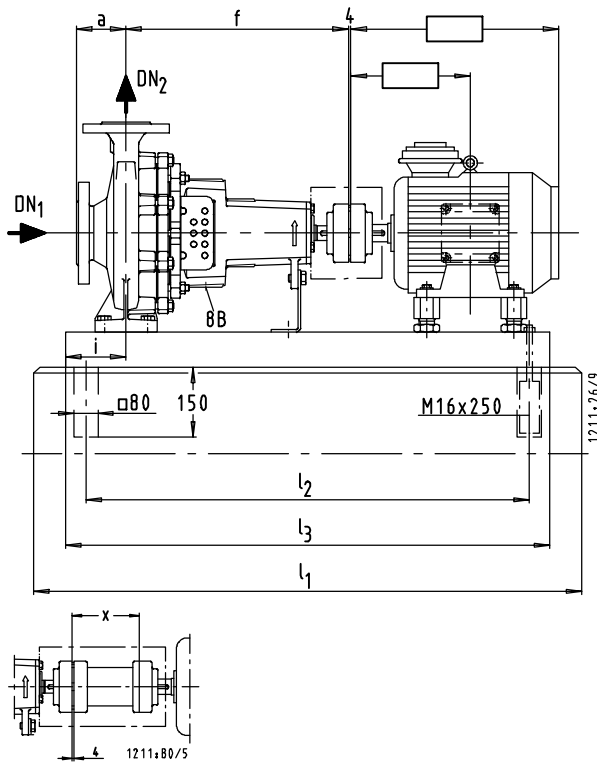


Fig. A

mm

Etanorm	Moteur				Taille	Fig.																	
	1450	1750	2900	3500			DN ₁	DN ₂	a	b ₁	b ₂	b ₃	f	h ₁	h ₂	i	l ₁	l ₂	l ₃	l ₁	l ₂	l ₃	x
32-125.1	0,55	0,55	-	-	80	A	50	32	80	450	240	300	360	212	140	100	860	650	710	950	740	800	100
	-	-	0,55	-	71	A	50	32	80	450	240	300	360	212	140	100	860	650	710	950	740	800	100
	-	-	0,75	-	80	A	50	32	80	450	240	300	360	212	140	100	860	650	710	950	740	800	100
	-	-	1,1	1,1	80	A	50	32	80	450	240	300	360	212	140	100	860	650	710	950	740	800	100
	-	-	1,5	1,5	90S	A	50	32	80	450	240	300	360	212	140	100	860	650	710	950	740	800	100
	-	-	2,2	2,2	90L	A	50	32	80	450	240	300	360	212	140	100	950	740	800	1050	840	900	100
	-	-	3,0	3,0	100L	A	50	32	80	450	240	300	360	212	140	100	1050	840	900	1150	940	1000	100
	-	-	4,0	4,0	112M	A	50	32	80	450	240	300	360	212	140	100	1050	840	900	1150	940	1000	100
	-	-	5,5	5,5	132S	A	50	32	80	450	240	300	360	232	140	100	1050	840	900	1150	940	1000	100
32-160.1	0,55	0,55	-	-	80	A	50	32	80	450	240	300	360	232	160	100	860	650	710	950	740	800	100
	-	0,75	-	-	80	A	50	32	80	450	240	300	360	232	160	100	860	650	710	950	740	800	100
	-	1,1	-	-	90S	A	50	32	80	450	240	300	360	232	160	100	860	650	710	950	740	800	100
	-	-	1,5	-	90S	A	50	32	80	450	240	300	360	232	160	100	860	650	710	950	740	800	100
	-	-	2,2	2,2	90L	A	50	32	80	450	240	300	360	232	160	100	950	740	800	1050	840	900	100
	-	-	3,0	3,0	100L	A	50	32	80	450	240	300	360	232	160	100	1050	840	900	1150	940	1000	100
	-	-	4,0	4,0	112M	A	50	32	80	450	240	300	360	232	160	100	1050	840	900	1150	940	1000	100
	-	-	5,5	5,5	132S	A	50	32	80	450	240	300	360	232	160	100	1050	840	900	1150	940	1000	100
	-	-	7,5	7,5	132S	A	50	32	80	450	240	300	360	232	160	100	1050	840	900	1150	940	1000	100
32-200.1	0,55	-	-	-	80	A	50	32	80	450	240	300	360	260	180	100	860	650	710	950	740	800	100
	0,75	0,75	-	-	80	A	50	32	80	450	240	300	360	260	180	100	860	650	710	950	740	800	100
	1,1	1,1	-	-	90S	A	50	32	80	450	240	300	360	260	180	100	860	650	710	950	740	800	100
	-	1,5	-	-	90L	A	50	32	80	450	240	300	360	260	180	100	950	740	800	1050	840	900	100
	-	2,2	-	-	100L	A	50	32	80	450	240	300	360	260	180	100	1050	840	900	1150	940	1000	100
	-	-	3,0	-	100L	A	50	32	80	450	240	300	360	260	180	100	1050	840	900	1150	940	1000	100
	-	-	4,0	-	112M	A	50	32	80	450	240	300	360	260	180	100	1050	840	900	1150	940	1000	100
	-	-	5,5	5,5	132S	A	50	32	80	450	240	300	360	260	180	100	1050	840	900	1150	940	1000	100
	-	-	7,5	7,5	132S	A	50	32	80	450	240	300	360	260	180	100	1050	840	900	1150	940	1000	100
	-	-	-	11,0	160M	A	50	32	80	500	280	350	360	260	180	100	1270	1060	1120	1270	1060	1120	100
32-250.1	0,75	-	-	-	80	A	50	32	100	500	280	350	360	280	225	112	1050	840	900	1050	840	900	100
	1,1	1,1	-	-	90S	A	50	32	100	500	280	350	360	280	225	112	1050	840	900	1050	840	900	100
	1,5	1,5	-	-	90L	A	50	32	100	500	280	350	360	280	225	112	1050	840	900	1050	840	900	100
	2,2	2,2	-	-	100L	A	50	32	100	500	280	350	360	280	225	112	1050	840	900	1050	840	900	100
	-	3,0	-	-	100L	A	50	32	100	500	280	350	360	280	225	112	1050	840	900	1050	840	900	100
	-	-	5,5	-	132S	A	50	32	100	500	280	350	360	280	225	112	1050	840	900	1150	940	1000	100
	-	-	7,5	-	132S	A	50	32	100	500	280	350	360	280	225	112	1050	840	900	1150	940	1000	100
	-	-	11,0	-	160M	A	50	32	100	500	280	350	360	280	225	112	1270	1060	1120	1270	1060	1120	100
	-	-	15,0	-	160M	A	50	32	100	500	280	350	360	280	225	112	1270	1060	1120	1270	1060	1120	100

Etanorm 32-125 - 32-250


Etanorm	Moteur				Taille	Fig.																	
	1 / min 1450 1750 2900 3500 kW																						
							DN ₁	DN ₂	a	b ₁	b ₂	b ₃	f	h ₁	h ₂	i							
							DN ₁	DN ₂	a	b ₁	b ₂	b ₃	f	h ₁	h ₂	i	l ₁	l ₂	l ₃	l ₁	l ₂	l ₃	x
32-125	0,55	0,55	-	-	80	A	50	32	80	450	240	300	360	212	140	100	860	650	710	950	740	800	100
	-	0,75	-	-	80	A	50	32	80	450	240	300	360	212	140	100	860	650	710	950	740	800	100
	-	-	1,1	-	80	A	50	32	80	450	240	300	360	212	140	100	860	650	710	950	740	800	100
	-	-	1,5	1,5	90S	A	50	32	80	450	240	300	360	212	140	100	860	650	710	950	740	800	100
	-	-	2,2	2,2	90L	A	50	32	80	450	240	300	360	212	140	100	950	740	800	1050	840	900	100
	-	-	3,0	3,0	100L	A	50	32	80	450	240	300	360	212	140	100	1050	840	900	1150	940	1000	100
	-	-	-	4,0	112M	A	50	32	80	450	240	300	360	212	140	100	1050	840	900	1150	940	1000	100
-	-	-	5,5	132S	A	50	32	80	450	240	300	360	232	140	100	1050	840	900	1150	940	1000	100	
32-160	0,55	0,55	-	-	80	A	50	32	80	450	240	300	360	232	160	100	860	650	710	950	740	800	100
	-	0,75	-	-	80	A	50	32	80	450	240	300	360	232	160	100	860	650	710	950	740	800	100
	-	1,1	-	-	90S	A	50	32	80	450	240	300	360	232	160	100	860	650	710	950	740	800	100
	-	-	2,2	-	90L	A	50	32	80	450	240	300	360	232	160	100	950	740	800	1050	840	900	100
	-	-	3,0	3,0	100L	A	50	32	80	450	240	300	360	232	160	100	1050	840	900	1150	940	1000	100
	-	-	4,0	4,0	112M	A	50	32	80	450	240	300	360	232	160	100	1050	840	900	1150	940	1000	100
	-	-	-	5,5	132S	A	50	32	80	450	240	300	360	232	160	100	1050	840	900	1150	940	1000	100
-	-	-	7,5	132S	A	50	32	80	450	240	300	360	232	160	100	1050	840	900	1150	940	1000	100	
32-200	0,55	-	-	-	80	A	50	32	80	450	240	300	360	260	180	100	860	650	710	950	740	800	100
	0,75	-	-	-	80	A	50	32	80	450	240	300	360	260	180	100	860	650	710	950	740	800	100
	1,1	1,1	-	-	90S	A	50	32	80	450	240	300	360	260	180	100	860	650	710	950	740	800	100
	-	1,5	-	-	90L	A	50	32	80	450	240	300	360	260	180	100	950	740	800	1050	840	900	100
	-	2,2	-	-	100L	A	50	32	80	450	240	300	360	260	180	100	1050	840	900	1150	940	1000	100
	-	-	4,0	-	112M	A	50	32	80	450	240	300	360	260	180	100	1050	840	900	1150	940	1000	100
	-	-	5,5	-	132S	A	50	32	80	450	240	300	360	260	180	100	1050	840	900	1150	940	1000	100
	-	-	7,5	7,5	132S	A	50	32	80	450	240	300	360	260	180	100	1050	840	900	1150	940	1000	100
	-	-	11,0	11,0	160M	A	50	32	80	500	280	350	360	260	180	100	1270	1060	1120	1270	1060	1120	100
	-	-	-	15,0	160M	A	50	32	80	500	280	350	360	260	180	100	1270	1060	1120	1270	1060	1120	100
32-250	1,1	-	-	-	90S	A	50	32	100	500	280	350	360	280	225	112	1050	840	900	1050	840	900	100
	1,5	1,5	-	-	90L	A	50	32	100	500	280	350	360	280	225	112	1050	840	900	1050	840	900	100
	2,2	2,2	-	-	100L	A	50	32	100	500	280	350	360	280	225	112	1050	840	900	1050	840	900	100
	-	3,0	-	-	100L	A	50	32	100	500	280	350	360	280	225	112	1050	840	900	1050	840	900	100
	-	4,0	-	-	112M	A	50	32	100	500	280	350	360	280	225	112	1050	840	900	1050	840	900	100
	-	5,5	-	-	132S	A	50	32	100	500	280	350	360	280	225	112	1050	840	900	1150	940	1000	100
	-	-	7,5	-	132S	A	50	32	100	500	280	350	360	280	225	112	1050	840	900	1150	940	1000	100
	-	-	11,0	-	160M	A	50	32	100	500	280	350	360	280	225	112	1270	1060	1120	1270	1060	1120	100
	-	-	15,0	-	160M	A	50	32	100	500	280	350	360	280	225	112	1270	1060	1120	1270	1060	1120	100

Etanorm 40-125 - 40-315

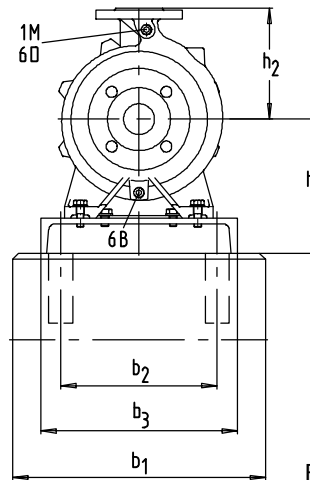
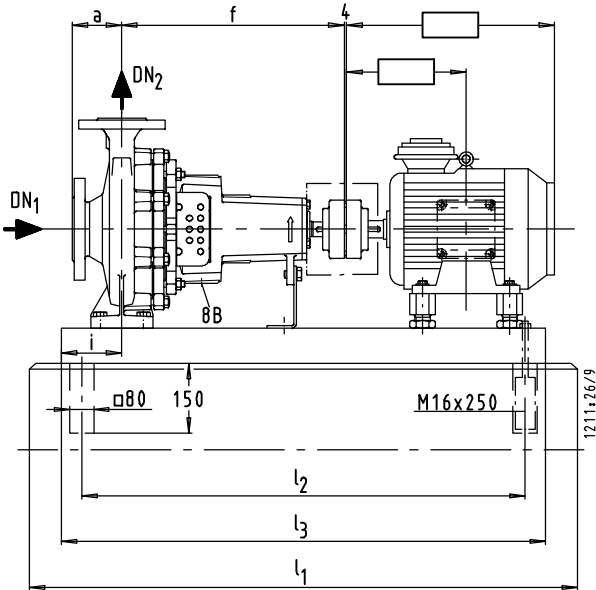
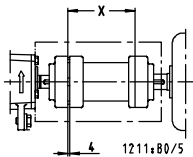


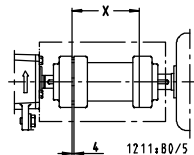
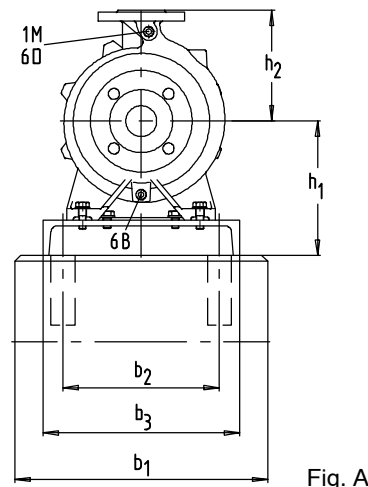
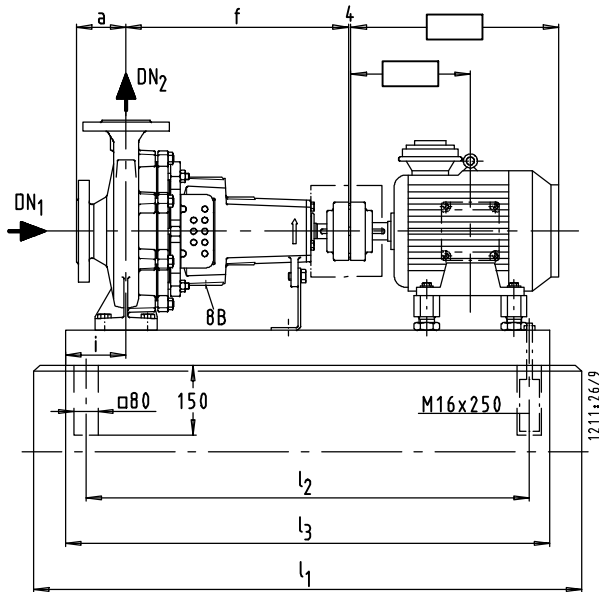
Fig. A



mm

Etanorm	Moteur 1 / min 1450 1750 2900 3500 kW				Taille	Fig.																		
	DN ₁	DN ₂	a	b ₁			b ₂	b ₃	f	h ₁	h ₂	i	l ₁	l ₂	l ₃	l ₁	l ₂	l ₃	x					
40-125	0,55	0,55	-	-	80	A	65	40	80	450	240	300	360	212	140	100	860	650	710	950	740	800	100	
	-	0,75	-	-	80	A	65	40	80	450	240	300	360	212	140	100	860	650	710	950	740	800	100	
	-	1,1	-	-	90S	A	65	40	80	450	240	300	360	212	140	100	860	650	710	950	740	800	100	
	-	-	1,5	-	90L	A	65	40	80	450	240	300	360	212	140	100	860	650	710	950	740	800	100	
	-	-	2,2	-	90L	A	65	40	80	450	240	300	360	212	140	100	950	740	800	1050	840	900	100	
	-	-	3,0	-	100L	A	65	40	80	450	240	300	360	212	140	100	1050	840	900	1150	940	1000	100	
	-	-	4,0	4,0	112M	A	65	40	80	450	240	300	360	212	140	100	1050	840	900	1150	940	1000	100	
	-	-	-	5,5	132S	A	65	40	80	450	240	300	360	232	140	100	1050	840	900	1150	940	1000	100	
	-	-	-	7,5	132S	A	65	40	80	450	240	300	360	232	140	100	1050	840	900	1150	940	1000	100	
	-	-	-	11,0	160M	A	65	40	80	500	280	350	360	260	140	100	1150	940	1000	1270	1060	1120	100	
40-160	0,55	-	-	-	80	A	65	40	80	450	240	300	360	232	160	100	860	650	710	950	740	800	100	
	0,75	0,75	-	-	80	A	65	40	80	450	240	300	360	232	160	100	860	650	710	950	740	800	100	
	1,1	1,1	-	-	90S	A	65	40	80	450	240	300	360	232	160	100	860	650	710	950	740	800	100	
	-	1,5	-	-	90L	A	65	40	80	450	240	300	360	232	160	100	950	740	800	1050	840	900	100	
	-	2,2	-	-	100L	A	65	40	80	450	240	300	360	232	160	100	1050	840	900	1150	940	1000	100	
	-	-	3,0	-	100L	A	65	40	80	450	240	300	360	232	160	100	1050	840	900	1150	940	1000	100	
	-	-	4,0	-	112M	A	65	40	80	450	240	300	360	232	160	100	1050	840	900	1150	940	1000	100	
	-	-	5,5	5,5	132S	A	65	40	80	450	240	300	360	232	160	100	1050	840	900	1150	940	1000	100	
	-	-	7,5	7,5	132S	A	65	40	80	450	240	300	360	232	160	100	1050	840	900	1150	940	1000	100	
	-	-	11,0	11,0	160M	A	65	40	80	500	280	350	360	260	160	100	1270	1060	1120	1270	1060	1120	100	
40-200	0,75	-	-	-	80	A	65	40	100	450	240	300	360	260	180	100	860	650	710	950	740	800	100	
	1,1	-	-	-	90S	A	65	40	100	450	240	300	360	260	180	100	860	650	710	950	740	800	100	
	1,5	1,5	-	-	90L	A	65	40	100	450	240	300	360	260	180	100	950	740	800	1050	840	900	100	
	-	2,2	-	-	100L	A	65	40	100	450	240	300	360	260	180	100	1050	840	900	1150	940	1000	100	
	-	3,0	-	-	100L	A	65	40	100	450	240	300	360	260	180	100	1050	840	900	1150	940	1000	100	
	-	-	5,5	-	132S	A	65	40	100	450	240	300	360	260	180	100	1050	840	900	1150	940	1000	100	
	-	-	7,5	-	132S	A	65	40	100	450	240	300	360	260	180	100	1050	840	900	1150	940	1000	100	
	-	-	11,0	11,0	160M	A	65	40	100	500	280	350	360	260	180	100	1270	1060	1120	1270	1060	1120	100	
	-	-	15,0	15,0	160M	A	65	40	100	500	280	350	360	260	180	100	1270	1060	1120	1270	1060	1120	100	
	-	-	18,5	18,5	160L	A	65	40	100	500	280	350	360	260	180	100	1270	1060	1120	1400	1190	1250	100	
-	-	22,0	22,0	180M	A	65	40	100	550	320	400	360	290	180	100	1400	1190	1250	1400	1190	1250	100		
40-250	1,1	-	-	-	90S	A	65	40	100	500	280	350	360	280	225	112	1050	840	900	1050	840	900	100	
	1,5	-	-	-	90L	A	65	40	100	500	280	350	360	280	225	112	1050	840	900	1050	840	900	100	
	2,2	2,2	-	-	100L	A	65	40	100	500	280	350	360	280	225	112	1050	840	900	1050	840	900	100	
	3,0	3,0	-	-	100L	A	65	40	100	500	280	350	360	280	225	112	1050	840	900	1050	840	900	100	
	-	4,0	-	-	112M	A	65	40	100	500	280	350	360	280	225	112	1050	840	900	1050	840	900	100	
	-	5,5	-	-	132S	A	65	40	100	500	280	350	360	280	225	112	1050	840	900	1150	940	1000	100	
	-	-	11,0	-	160M	A	65	40	100	500	280	350	360	280	225	112	1270	1060	1120	1270	1060	1120	100	
	-	-	15,0	-	160M	A	65	40	100	500	280	350	360	280	225	112	1270	1060	1120	1270	1060	1120	100	
	-	-	18,5	-	160L	A	65	40	100	500	280	350	360	280	225	112	1270	1060	1120	1400	1190	1250	100	
	-	-	22,0	22,0	180M	A	65	40	100	550	320	400	360	290	225	112	1400	1190	1250	1400	1190	1250	100	
40-315	2,2	-	-	-	200L	A	65	40	125	500	280	350	470	325	250	112	1050	840	900	1150	940	1000	100	
	3,0	-	-	-	100L	A	65	40	125	500	280	350	470	325	250	112	1050	840	900	1150	940	1000	100	
	4,0	-	-	-	112M	A	65	40	125	500	280	350	470	325	250	112	1150	940	1000	1270	1060	1120	100	
	5,5	5,5	-	-	132S	A	65	40	125	500	280	350	470	325	250	112	1150	940	1000	1270	1060	1120	100	
	-	7,5	-	-	132M	A	65	40	125	500	280	350	470	325	250	112	1270	1060	1120	1270	1060	1120	100	
	-	11,0	-	-	160M	A	65	40	125	550	320	400	470	335	250	112	1400	1190	1250	1400	1190	1250	100	

Etanorm 50-125 - 50-315



Etanorm	Moteur 1 / min 1450 1750 2900 3500 kW				Taille	Fig.																	
							DN ₁	DN ₂	a	b ₁	b ₂	b ₃	f	h ₁	h ₂	i	l ₁	l ₂	l ₃	l ₁	l ₂	l ₃	x
50-125	0,55	-	-	-	80	A	65	50	100	450	240	300	360	232	160	100	860	650	710	950	740	800	100
	0,75	0,75	-	-	80	A	65	50	100	450	240	300	360	232	160	100	860	650	710	950	740	800	100
	1,1	1,1	-	-	90S	A	65	50	100	450	240	300	360	232	160	100	860	650	710	950	740	800	100
	-	1,5	-	-	90L	A	65	50	100	450	240	300	360	232	160	100	950	740	800	1050	840	900	100
	-	-	3,0	-	100L	A	65	50	100	450	240	300	360	232	160	100	1050	840	900	1150	940	1000	100
	-	-	4,0	-	112M	A	65	50	100	450	240	300	360	232	160	100	1050	840	900	1150	940	1000	100
	-	-	5,5	5,5	132S	A	65	50	100	450	240	300	360	232	160	100	1050	840	900	1150	940	1000	100
	-	-	7,5	7,5	132S	A	65	50	100	450	240	300	360	232	160	100	1050	840	900	1150	940	1000	100
	-	-	11,0	11,0	160M	A	65	50	100	500	280	350	360	260	160	100	1270	1060	1120	1270	1060	1120	100
	-	-	15,0	15,0	160M	A	65	50	100	500	280	350	360	260	160	100	1270	1060	1120	1270	1060	1120	100
50-160	0,75	-	-	-	80	A	65	50	100	450	240	300	360	260	180	100	860	650	710	950	740	800	100
	1,1	1,1	-	-	90S	A	65	50	100	450	240	300	360	260	180	100	860	650	710	950	740	800	100
	1,5	1,5	-	-	90L	A	65	50	100	450	240	300	360	260	180	100	950	740	800	1050	840	900	100
	-	2,2	-	-	100L	A	65	50	100	450	240	300	360	260	180	100	1050	840	900	1150	940	1000	100
	-	3,0	-	-	100L	A	65	50	100	450	240	300	360	260	180	100	1050	840	900	1150	940	1000	100
	-	-	5,5	-	132S	A	65	50	100	450	240	300	360	260	180	100	1050	840	900	1150	940	1000	100
	-	-	7,5	5,5	132S	A	65	50	100	450	240	300	360	260	180	100	1050	840	900	1150	940	1000	100
	-	-	11,0	11,0	160M	A	65	50	100	500	280	350	360	260	180	100	1270	1060	1120	1270	1060	1120	100
	-	-	15,0	15,0	160M	A	65	50	100	500	280	350	360	260	180	100	1270	1060	1120	1270	1060	1120	100
	-	-	18,5	18,5	160L	A	65	50	100	500	280	350	360	260	180	100	1270	1060	1120	1400	1190	1250	100
-	-	22,0	22,0	180M	A	65	50	100	550	320	400	360	290	180	100	1400	1190	1250	1400	1190	1250	100	
50-200	1,5	-	-	-	90L	A	65	50	100	450	240	300	360	260	200	100	950	740	800	1050	840	900	100
	2,2	2,2	-	-	100L	A	65	50	100	450	240	300	360	260	200	100	1050	840	900	1150	940	1000	100
	3,0	3,0	-	-	100L	A	65	50	100	450	240	300	360	260	200	100	1050	840	900	1150	940	1000	100
	-	4,0	-	-	112M	A	65	50	100	450	240	300	360	260	200	100	1050	840	900	1150	940	1000	100
	-	5,5	-	-	132S	A	65	50	100	450	240	300	360	260	200	100	1050	840	900	1150	940	1000	100
	-	-	11,0	-	160M	A	65	50	100	500	280	350	360	260	200	100	1270	1060	1120	1270	1060	1120	100
	-	-	15,0	-	160M	A	65	50	100	500	280	350	360	260	200	100	1270	1060	1120	1270	1060	1120	100
	-	-	18,5	-	160L	A	65	50	100	500	280	350	360	260	200	100	1270	1060	1120	1400	1190	1250	100
	-	-	22,0	22,0	180M	A	65	50	100	550	320	400	360	290	200	100	1400	1190	1250	1400	1190	1250	100
	-	-	30,0	30,0	200L	A	65	50	100	550	320	400	360	310	200	100	1400	1190	1250	1400	1190	1250	100
50-250	2,2	-	-	-	100L	A	65	50	100	500	280	350	360	280	225	112	1050	840	900	1050	840	900	100
	3,0	-	-	-	100L	A	65	50	100	500	280	350	360	280	225	112	1050	840	900	1050	840	900	100
	4,0	4,0	-	-	112M	A	65	50	100	500	280	350	360	280	225	112	1050	840	900	1050	840	900	100
	-	5,5	-	-	132S	A	65	50	100	500	280	350	360	280	225	112	1050	840	900	1150	940	1000	100
	-	7,5	-	-	132M	A	65	50	100	500	280	350	360	280	225	112	1150	940	1000	1270	1060	1120	100
	-	11,0	-	-	160M	A	65	50	100	500	280	350	360	280	225	112	1270	1060	1120	1270	1060	1120	100
	-	-	15,0	-	160M	A	65	50	100	500	280	350	360	280	225	112	1270	1060	1120	1270	1060	1120	100
	-	-	18,5	-	160L	A	65	50	100	500	280	350	360	280	225	112	1270	1060	1120	1400	1190	1250	100
	-	-	22,0	22,0	180M	A	65	50	100	550	320	400	360	290	225	112	1400	1190	1250	1400	1190	1250	100
	-	-	30,0	30,0	200L	A	65	50	100	550	320	400	360	310	225	112	1400	1190	1250	1400	1190	1250	100
50-315	3,0	-	-	-	100L	A	65	50	125	500	280	350	470	325	280	112	1050	840	900	1150	940	1000	100
	4,0	-	-	-	112M	A	65	50	125	500	280	350	470	325	280	112	1150	940	1000	1270	1060	1120	100
	5,5	-	-	-	132S	A	65	50	125	500	280	350	470	325	280	112	1150	940	1000	1270	1060	1120	100
	7,5	7,5	-	-	132M	A	65	50	125	500	280	350	470	325	280	112	1270	1060	1120	1270	1060	1120	100
	-	11,0	-	-	160M	A	65	50	125	550	320	400	470	335	280	112	1400	1190	1250	1400	1190	1250	100
	-	15,0	-	-	160L	A	65	50	125	550	320	400	470	335	280	112	1400	1190	1250	1400	1190	1250	100

Etanorm 65-125 - 65-200

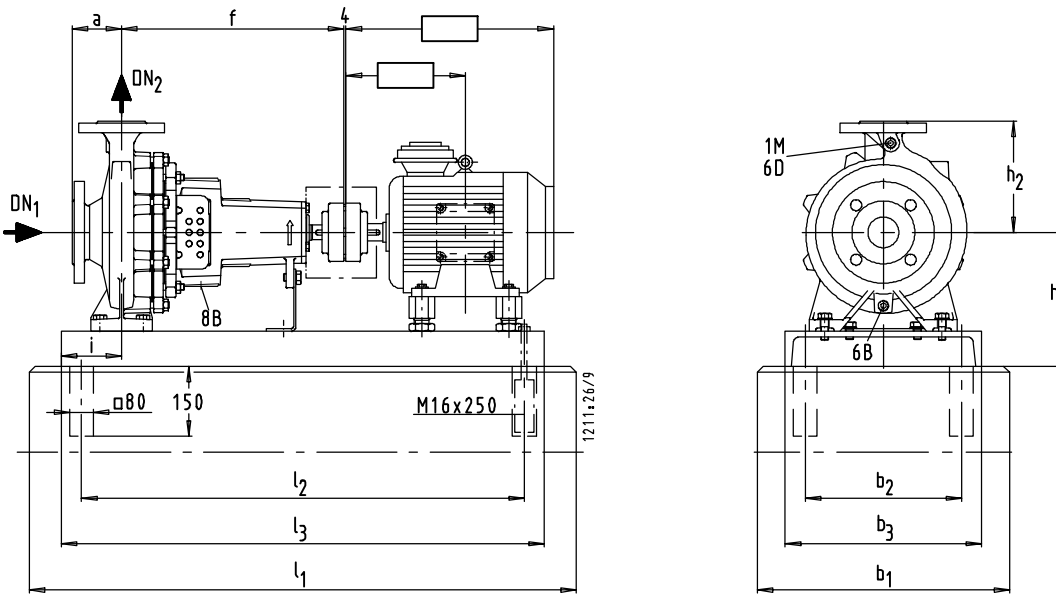
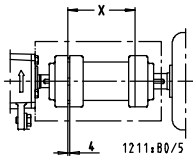


Fig. A



mm

Etanorm	Moteur				Taille	Fig.																		
	1450	1750	2900	3500			1 / min	DN ₁	DN ₂	a	b ₁	b ₂	b ₃	f	h ₁	h ₂	i	l ₁	l ₂	l ₃	l ₁	l ₂	l ₃	x
65-125	0,55	-	-	-	80	A	80	65	100	450	240	300	360	260	180	112	860	650	710	950	740	800	100	
	0,75	-	-	-	80	A	80	65	100	450	240	300	360	260	180	112	860	650	710	950	740	800	100	
	1,1	1,1	-	-	90S	A	80	65	100	450	240	300	360	260	180	112	860	650	710	950	740	800	100	
	-	1,5	-	-	90L	A	80	65	100	450	240	300	360	260	180	112	950	740	800	1050	840	900	100	
	-	2,2	-	-	100L	A	80	65	100	450	240	300	360	260	180	112	1050	840	900	1150	940	1000	100	
	-	-	4,0	-	112M	A	80	65	100	450	240	300	360	260	180	112	1050	840	900	1150	940	1000	100	
	-	-	5,5	-	132S	A	80	65	100	450	240	300	360	260	180	112	1050	840	900	1150	940	1000	100	
	-	-	7,5	7,5	132S	A	80	65	100	450	240	300	360	260	180	112	1050	840	900	1150	940	1000	100	
	-	-	11,0	11,0	160M	A	80	65	100	500	280	350	360	260	180	112	1270	1060	1120	1270	1060	1120	100	
	-	-	-	15,0	160M	A	80	65	100	500	280	350	360	260	180	112	1270	1060	1120	1270	1060	1120	100	
	65-160	1,1	-	-	-	90S	A	80	65	100	450	240	300	360	260	200	112	860	650	710	950	740	800	100
		1,5	1,5	-	-	90L	A	80	65	100	450	240	300	360	260	200	112	950	740	800	1050	840	900	100
2,2		2,2	-	-	100L	A	80	65	100	450	240	300	360	260	200	112	1050	840	900	1150	940	1000	100	
-		3,0	-	-	100L	A	80	65	100	450	240	300	360	260	200	112	1050	840	900	1150	940	1000	100	
-		4,0	-	-	112M	A	80	65	100	450	240	300	360	260	200	112	1050	840	900	1150	940	1000	100	
-		-	7,5	-	132S	A	80	65	100	450	240	300	360	260	200	112	1050	840	900	1150	940	1000	100	
-		-	11,0	-	160M	A	80	65	100	500	280	350	360	260	200	112	1270	1060	1120	1270	1060	1120	100	
-		-	15,0	15,0	160M	A	80	65	100	500	280	350	360	260	200	112	1270	1060	1120	1270	1060	1120	100	
-		-	-	18,5	160L	A	80	65	100	500	280	350	360	260	200	112	1270	1060	1120	1400	1190	1250	100	
-		-	-	22,0	180M	A	80	65	100	550	320	400	360	290	200	112	1400	1190	1250	1400	1190	1250	100	
-		-	-	30,0	200L	A	80	65	100	550	320	400	360	310	200	112	1400	1190	1250	1400	1190	1250	100	
65-200		2,2	-	-	-	100L	A	80	65	100	500	280	350	360	280	225	112	1050	840	900	1150	940	1000	140
	3,0	3,0	-	-	100L	A	80	65	100	500	280	350	360	280	225	112	1050	840	900	1150	940	1000	140	
	4,0	4,0	-	-	112M	A	80	65	100	500	280	350	360	280	225	112	1050	840	900	1150	940	1000	140	
	-	5,5	-	-	132S	A	80	65	100	500	280	350	360	280	225	112	1050	840	900	1150	940	1000	140	
	-	7,5	-	-	132M	A	80	65	100	500	280	350	360	280	225	112	1150	940	1000	1270	1060	1120	140	
	-	-	15,0	-	160M	A	80	65	100	500	280	350	360	280	225	112	1270	1060	1120	1400	1190	1250	140	
	-	-	18,5	-	160L	A	80	65	100	500	280	350	360	280	225	112	1270	1060	1120	1400	1190	1250	140	
	-	-	22,0	22,0	180M	A	80	65	100	550	320	400	360	290	225	112	1400	1190	1250	1400	1190	1250	140	
	-	-	30,0	30,0	200L	A	80	65	100	550	320	400	360	310	225	112	1400	1190	1250	1400	1190	1250	140	
	-	-	-	37,0	200L	A	80	65	100	550	320	400	360	310	225	112	1400	1190	1250	1400	1190	1250	140	

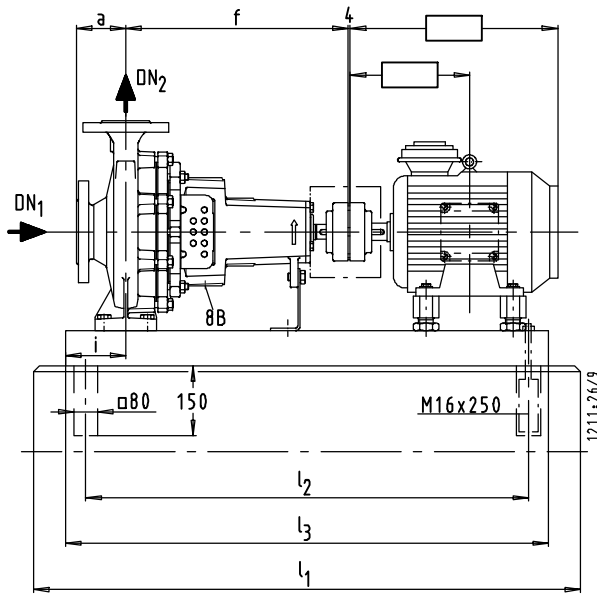
Etanorm 65-250 - 65-315


Fig. A

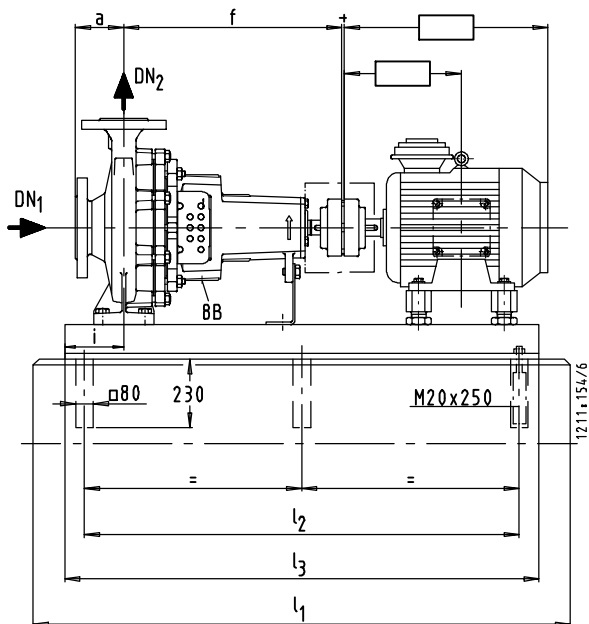
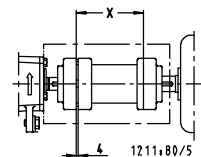


Fig. B



Etanorm	Moteur				Fig.														mm				
	1 / min 1450 1750 2900 3500 kW					Taille	DN ₁	DN ₂	a	b ₁	b ₂	b ₃	f	h ₁	h ₂	i	l ₁	l ₂	l ₃	l ₁	l ₂	l ₃	x
65-250	3,0	-	-	-	100L	A	80	65	100	550	320	400	470	310	250	130	1150	940	1000	1400	1190	1250	140
	4,0	-	-	-	112M	A	80	65	100	550	320	400	470	310	250	130	1150	940	1000	1400	1190	1250	140
	5,5	5,5	-	-	132S	A	80	65	100	550	320	400	470	310	250	130	1150	940	1000	1400	1190	1250	140
	-	7,5	-	-	132M	A	80	65	100	550	320	400	470	310	250	130	1150	940	1000	1400	1190	1250	140
	-	11,0	-	-	160M	A	80	65	100	550	320	400	470	310	250	130	1400	1190	1250	1570	1360	1420	140
	-	-	22,0	-	180M	A	80	65	100	550	320	400	470	310	250	130	1400	1190	1250	1570	1360	1420	140
	-	-	30,0	-	200L	A	80	65	100	550	320	400	470	310	250	130	1400	1190	1250	1570	1360	1420	140
	-	-	37,0	-	200L	A	80	65	100	550	320	400	470	310	250	130	1400	1190	1250	1570	1360	1420	140
	-	-	45,0	-	225M	B	80	65	100	750	550	590	470	365	250	130	1550	940	1400	1550	940	1400	140
	65-315	5,5	-	-	-	132S	A	80	65	125	550	320	400	470	335	280	130	1150	940	1000	1400	1190	1250
7,5		-	-	-	132M	A	80	65	125	550	320	400	470	335	280	130	1150	940	1000	1400	1190	1250	140
11,0		11,0	-	-	160M	A	80	65	125	550	320	400	470	335	280	130	1400	1190	1250	1570	1360	1420	140
-		15,0	-	-	160L	A	80	65	125	550	320	400	470	335	280	130	1400	1190	1250	1570	1360	1420	140
-		18,5	-	-	180M	A	80	65	125	550	320	400	470	335	280	130	1400	1190	1250	1570	1360	1420	140
-		22,0	-	-	180L	A	80	65	125	550	320	400	470	335	280	130	1400	1190	1250	1570	1360	1420	140

Etanorm 80-160 - 80-250

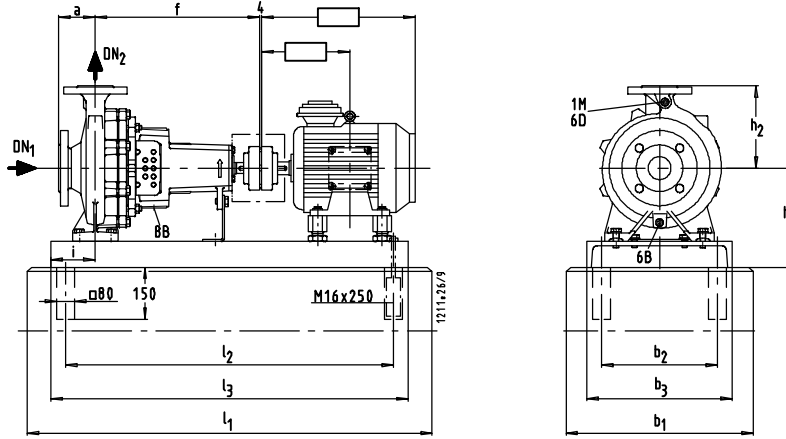


Fig. A

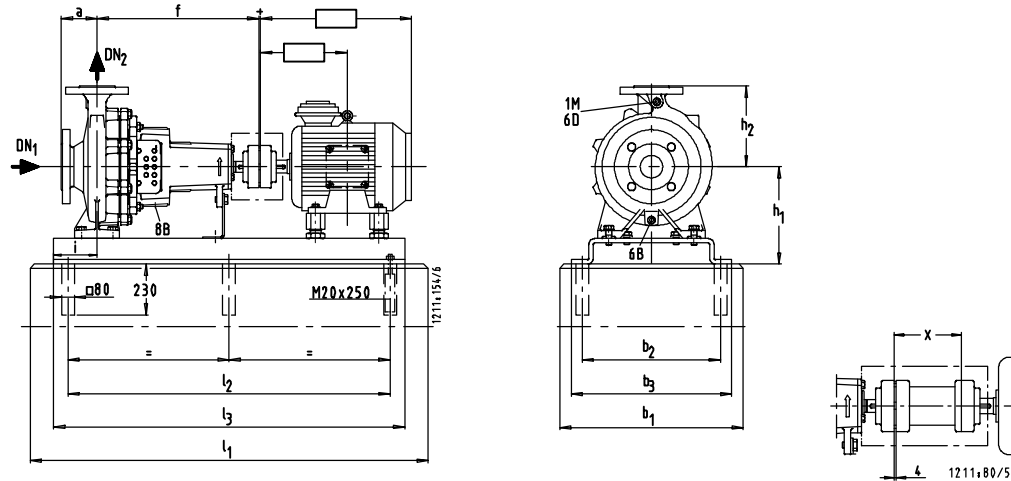


Fig. B

Etanorm	Moteur 1 / min 1450 1750 2900 3500 kW				Taille	Fig.																	
	DN ₁	DN ₂	a	b ₁			b ₂	b ₃	f	h ₁	h ₂	i	l ₁	l ₂	l ₃	l ₁	l ₂	l ₃	x				
80-160	1,5	-	-	-	90L	A	100	80	125	500	280	350	360	280	225	112	1050	840	900	1050	840	900	140
	2,2	-	-	-	100L	A	100	80	125	500	280	350	360	280	225	112	1050	840	900	1150	940	1000	140
	3,0	3,0	-	-	100L	A	100	80	125	500	280	350	360	280	225	112	1050	840	900	1150	940	1000	140
	-	4,0	-	-	112M	A	100	80	125	500	280	350	360	280	225	112	1050	840	900	1150	940	1000	140
	-	5,5	-	-	132S	A	100	80	125	500	280	350	360	280	225	112	1050	840	900	1150	940	1000	140
	-	-	15,0	-	160M	A	100	80	125	500	280	350	360	280	225	112	1270	1060	1120	1400	1190	1250	140
	-	-	18,5	-	160L	A	100	80	125	500	280	350	360	280	225	112	1270	1060	1120	1400	1190	1250	140
	-	-	22,0	22,0	180M	A	100	80	125	550	320	400	360	290	225	112	1400	1190	1250	1400	1190	1250	140
	-	-	30,0	30,0	200L	A	100	80	125	550	320	400	360	310	225	112	1400	1190	1250	1400	1190	1250	140
	-	-	37,0	37,0	200L	A	100	80	125	550	320	400	360	310	225	112	1400	1190	1250	1400	1190	1250	140
80-200	2,2	-	-	-	100L	A	100	80	125	500	280	350	470	280	250	112	1150	940	1000	1270	1060	1120	140
	3,0	-	-	-	100L	A	100	80	125	500	280	350	470	280	250	112	1150	940	1000	1270	1060	1120	140
	4,0	-	-	-	112M	A	100	80	125	500	280	350	470	280	250	112	1150	940	1000	1270	1060	1120	140
	5,5	5,5	-	-	132S	A	100	80	125	500	280	350	470	280	250	112	1150	940	1000	1270	1060	1120	140
	-	7,5	-	-	132M	A	100	80	125	500	280	350	470	280	250	112	1270	1060	1120	1400	1190	1250	140
	-	11,0	-	-	160M	A	100	80	125	500	280	350	470	280	250	112	1270	1060	1120	1400	1190	1250	140
	-	-	18,5	-	160L	A	100	80	125	550	320	400	470	290	250	112	1400	1190	1250	1570	1360	1420	140
	-	-	22,0	-	180M	A	100	80	125	550	320	400	470	290	250	112	1400	1190	1250	1570	1360	1420	140
	-	-	30,0	-	200L	A	100	80	125	550	320	400	470	310	250	112	1400	1190	1250	1570	1360	1420	140
	-	-	37,0	-	200L	A	100	80	125	550	320	400	470	310	250	112	1400	1190	1250	1570	1360	1420	140
80-250	4,0	-	-	-	112M	A	100	80	125	550	320	400	470	310	280	130	1150	940	1000	1400	1190	1250	140
	5,5	-	-	-	132S	A	100	80	125	550	320	400	470	310	280	130	1150	940	1000	1400	1190	1250	140
	7,5	7,5	-	-	132M	A	100	80	125	550	320	400	470	310	280	130	1150	940	1000	1400	1190	1250	140
	11,0	11,0	-	-	160M	A	100	80	125	550	320	400	470	310	280	130	1400	1190	1250	1570	1360	1420	140
	-	15,0	-	-	160L	A	100	80	125	550	320	400	470	310	280	130	1400	1190	1250	1570	1360	1420	140
	-	18,5	-	-	180M	A	100	80	125	550	320	400	470	310	280	130	1400	1190	1250	1570	1360	1420	140
	-	-	30,0	-	200L	A	100	80	125	550	320	400	470	310	280	130	1400	1190	1250	1570	1360	1420	140
	-	-	37,0	-	200L	A	100	80	125	550	320	400	470	310	280	130	1400	1190	1250	1570	1360	1420	140
	-	-	45,0	-	225M	B	100	80	125	750	550	590	470	365	280	130	1550	940	1400	1550	940	1400	140
	-	-	55,0	-	250M	B	100	80	125	810	600	650	470	390	280	130	1750	1060	1600	1750	1060	1600	140
-	-	75,0	-	280S	B	100	80	125	880	670	720	470	420	280	130	1750	1060	1600	1750	1060	1600	140	

Etanorm 80-315 - 80-400

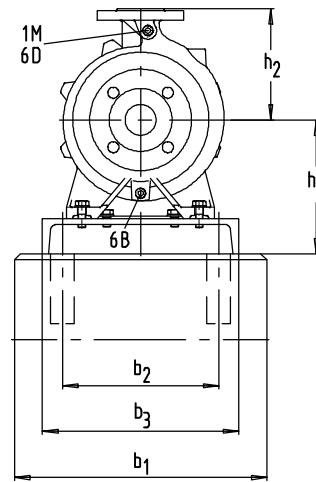
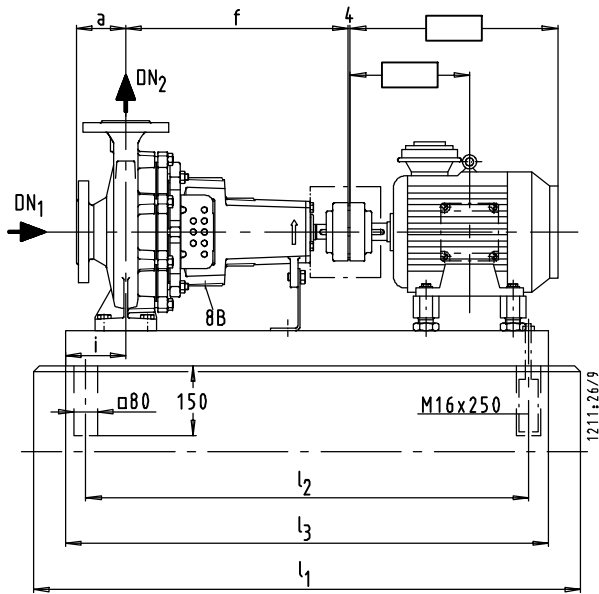


Fig. A

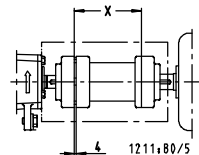
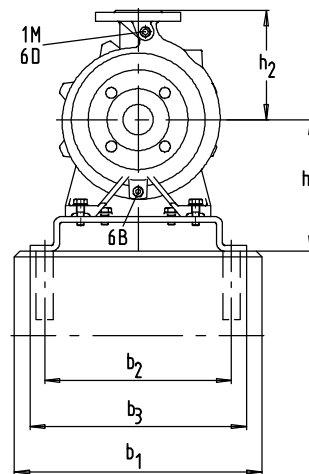
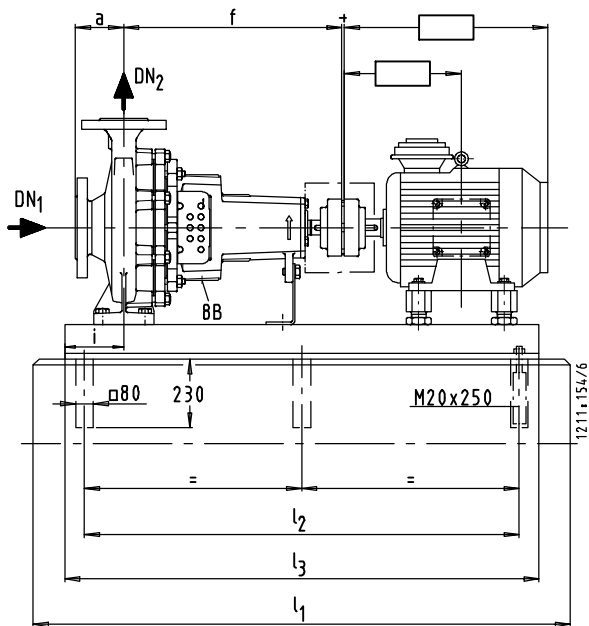


Fig. B

Etanorm	Moteur 1 / min 1450 1750 2900 3500 kW				Taille	Fig.																	
	DN ₁	DN ₂	a	b ₁			b ₂	b ₃	f	h ₁	h ₂	i	l ₁	l ₂	l ₃	l ₁	l ₂	l ₃	x				
80-315	7,5	-	-	-	132M	A	100	80	125	550	320	400	470	360	315	130	1150	940	1000	1400	1190	1250	140
	11,0	-	-	-	160M	A	100	80	125	550	320	400	470	360	315	130	1400	1190	1250	1570	1360	1420	140
	15,0	-	-	-	160L	A	100	80	125	550	320	400	470	360	315	130	1400	1190	1250	1570	1360	1420	140
	18,5	18,5	-	-	180M	A	100	80	125	550	320	400	470	360	315	130	1400	1190	1250	1570	1360	1420	140
	-	22,0	-	-	180L	A	100	80	125	550	320	400	470	360	315	130	1400	1190	1250	1570	1360	1420	140
	-	30,0	-	-	200L	B	100	80	125	750	550	590	470	390	315	130	1550	940	1400	1550	940	1400	140
80-400	-	37,0	-	-	225S	B	100	80	125	750	550	590	470	390	315	130	1550	940	1400	1550	940	1400	140
	11,0	-	-	-	160M	B	100	80	125	750	550	590	530	420	355	112	1550	940	1400	1550	940	1400	140
	15,0	-	-	-	160L	B	100	80	125	750	550	590	530	420	355	112	1550	940	1400	1550	940	1400	140
	18,5	-	-	-	180M	B	100	80	125	750	550	590	530	420	355	112	1550	940	1400	1550	940	1400	140
	22,0	-	-	-	180L	B	100	80	125	750	550	590	530	420	355	112	1550	940	1400	1550	940	1400	140
	30,0	30,0	-	-	200L	B	100	80	125	750	550	590	530	420	355	112	1550	940	1400	1550	940	1400	140
	-	37,0	-	-	225S	B	100	80	125	750	550	590	530	420	355	112	1550	940	1400	1550	940	1400	140
	-	45,0	-	-	225M	B	100	80	125	750	550	590	530	420	355	112	1550	940	1400	1550	940	1400	140
-	55,0	-	-	250M	B	100	80	125	810	600	650	530	420	355	112	1750	1060	1600	1750	1060	1600	140	

Etanorm 100-160 - 100-250

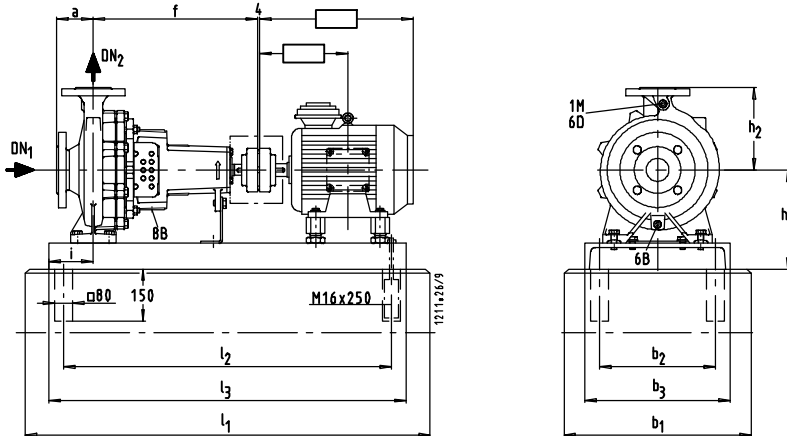


Fig. A

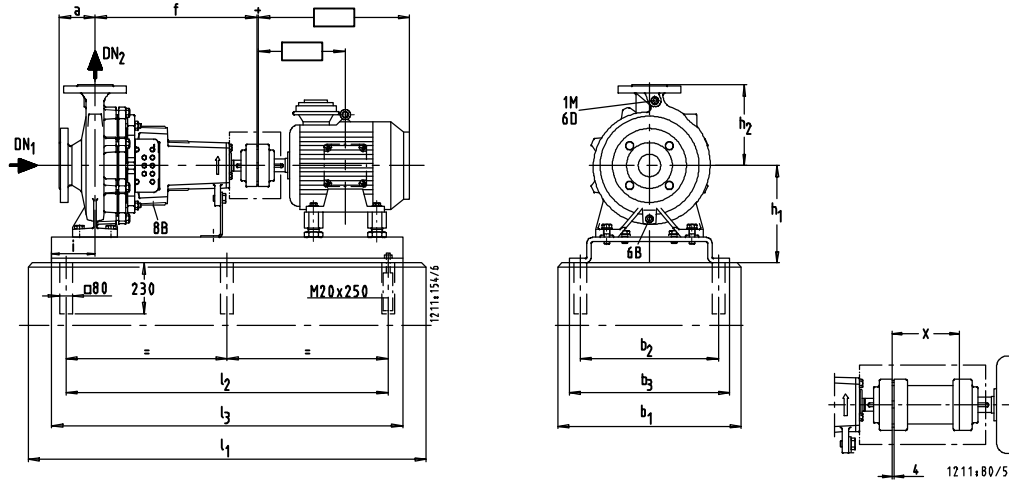


Fig. B

Etanorm	Moteur 1 / min 1450 1750 2900 3500 kW				Taille	Fig.																		mm
	DN ₁	DN ₂	a	b ₁			b ₂	b ₃	f	h ₁	h ₂	i	l ₁	l ₂	l ₃	l ₁	l ₂	l ₃	x					
100-160	3,0	-	-	-	100L	A	125	100	125	550	320	400	470	310	280	130	1150	940	1000	1400	1190	1250	140	
	4,0	-	-	-	112M	A	125	100	125	550	320	400	470	310	280	130	1150	940	1000	1400	1190	1250	140	
	-	5,5	-	-	132S	A	125	100	125	550	320	400	470	310	280	130	1150	940	1000	1400	1190	1250	140	
	-	7,5	-	-	132M	A	125	100	125	550	320	400	470	310	280	130	1150	940	1000	1400	1190	1250	140	
	-	-	22,0	-	180M	A	125	100	125	550	320	400	470	310	280	130	1400	1190	1250	1570	1360	1420	140	
	-	-	30,0	-	200L	A	125	100	125	550	320	400	470	310	280	130	1400	1190	1250	1570	1360	1420	140	
	-	-	37,0	37,0	200L	A	125	100	125	550	320	400	470	310	280	130	1400	1190	1250	1570	1360	1420	140	
	-	-	-	45,0	225M	B	125	100	125	750	550	590	470	365	280	130	1550	940	1400	1550	940	1400	140	
	-	-	-	55,0	250M	B	125	100	125	810	600	650	470	390	280	130	1750	1060	1600	1750	1060	1600	140	
	-	-	-	75,0	280S	B	125	100	125	880	670	720	470	420	280	130	1750	1060	1600	1750	1060	1600	140	
100-200	4,0	-	-	-	112M	A	125	100	125	550	320	400	470	310	280	130	1150	940	1000	1400	1190	1250	140	
	5,5	-	-	-	132S	A	125	100	125	550	320	400	470	310	280	130	1150	940	1000	1400	1190	1250	140	
	-	7,5	-	-	132M	A	125	100	125	550	320	400	470	310	280	130	1150	940	1000	1400	1190	1250	140	
	-	11,0	-	-	160M	A	125	100	125	550	320	400	470	310	280	130	1400	1190	1250	1570	1360	1420	140	
	-	15,0	-	-	160L	A	125	100	125	550	320	400	470	310	280	130	1400	1190	1250	1570	1360	1420	140	
	-	-	30	-	200L	A	125	100	125	550	320	400	470	310	280	130	1400	1190	1250	1570	1360	1420	140	
	-	-	37	-	200L	A	125	100	125	550	320	400	470	310	280	130	1400	1190	1250	1570	1360	1420	140	
	-	-	45	-	225M	B	125	100	125	750	550	590	470	365	280	130	1550	940	1400	1550	940	1400	140	
	-	-	55	-	250M	B	125	100	125	810	600	650	470	390	280	130	1750	1060	1600	1750	1060	1600	140	
	-	-	75	75	280S	B	125	100	125	880	670	720	470	420	280	130	1750	1060	1600	1750	1060	1600	140	
100-250	7,5	-	-	-	132M	A	125	100	140	550	320	400	470	335	280	130	1150	940	1000	1400	1190	1250	140	
	11,0	11,0	-	-	160M	A	125	100	140	550	320	400	470	335	280	130	1400	1190	1250	1570	1360	1420	140	
	15,0	15,0	-	-	160L	A	125	100	140	550	320	400	470	335	280	130	1400	1190	1250	1570	1360	1420	140	
	-	18,5	-	-	180M	A	125	100	140	550	320	400	470	335	280	130	1400	1190	1250	1570	1360	1420	140	
	-	22,0	-	-	180L	A	125	100	140	550	320	400	470	335	280	130	1400	1190	1250	1570	1360	1420	140	
	-	-	55	-	250M	B	125	100	140	810	600	650	470	390	280	130	1750	1060	1600	1750	1060	1600	140	
	-	-	75	-	280S	B	125	100	140	880	670	720	470	420	280	130	1750	1060	1600	1750	1060	1600	140	
	-	-	90	-	280M	B	125	100	140	880	670	720	470	420	280	130	1750	1060	1600	1750	1060	1600	140	
	-	-	110	-	315S	B	125	100	140	940	730	780	470	455	280	130	1800	1100	1650	1800	1100	1650	140	

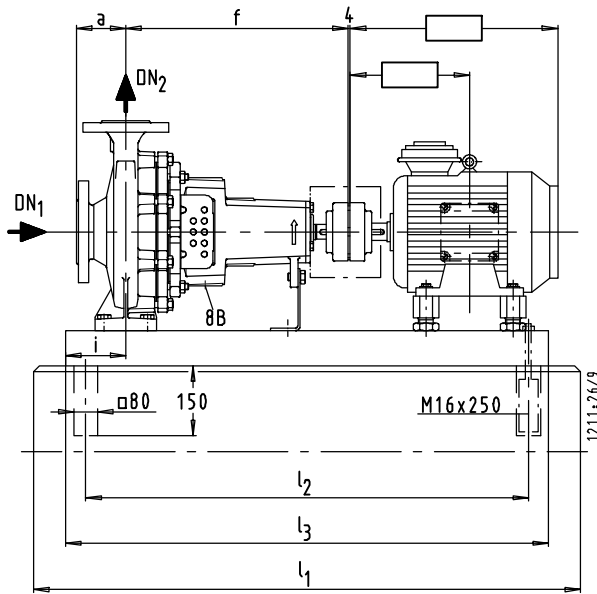
Etanorm 100-315 - 100-400


Fig. A

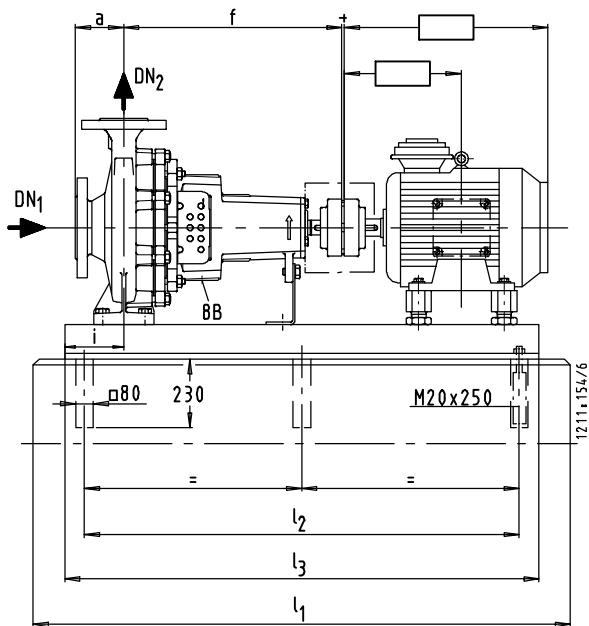


Fig. B

Etanorm	Moteur 1 / min 1450 1750 2900 3500 kW				Taille	Fig														mm			
	DN ₁	DN ₂	a	b ₁			b ₂	b ₃	f	h ₁	h ₂	i	l ₁	l ₂	l ₃	l ₁	l ₂	l ₃	x				
100-315	15,0	-	-	-	160L	A	125	100	140	550	320	400	470	360	315	130	1400	1190	1250	1570	1360	1420	140
	18,5	-	-	-	180M	A	125	100	140	550	320	400	470	360	315	130	1400	1190	1250	1570	1360	1420	140
	22,0	-	-	-	180L	A	125	100	140	550	320	400	470	360	315	130	1400	1190	1250	1570	1360	1420	140
	30,0	30,0	-	-	200L	B	125	100	140	750	550	590	470	390	315	130	1550	940	1400	1550	940	1400	140
	-	37,0	-	-	225S	B	125	100	140	750	550	590	470	390	315	130	1550	940	1400	1550	940	1400	140
	-	45,0	-	-	225M	B	125	100	140	750	550	590	470	390	315	130	1550	940	1400	1550	940	1400	140
100-400	22,0	-	-	-	180L	B	125	100	140	810	600	650	530	420	355	112	1750	1060	1600	1750	1060	1600	140
	30,0	-	-	-	200L	B	125	100	140	810	600	650	530	420	355	112	1750	1060	1600	1750	1060	1600	140
	37,0	37,0	-	-	225S	B	125	100	140	810	600	650	530	420	355	112	1750	1060	1600	1750	1060	1600	140
	-	45,0	-	-	225M	B	125	100	140	810	600	650	530	420	355	112	1750	1060	1600	1750	1060	1600	140
	-	55,0	-	-	250M	B	125	100	140	810	600	650	530	420	355	112	1750	1060	1600	1750	1060	1600	140
	-	75,0	-	-	280S	B	125	100	140	880	670	720	530	420	355	112	1750	1060	1600	1750	1060	1600	140

Etanorm 125-200 - 125-400

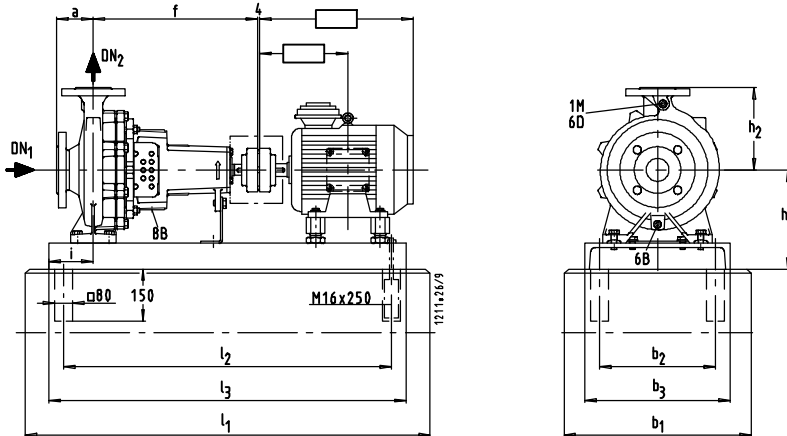


Fig. A

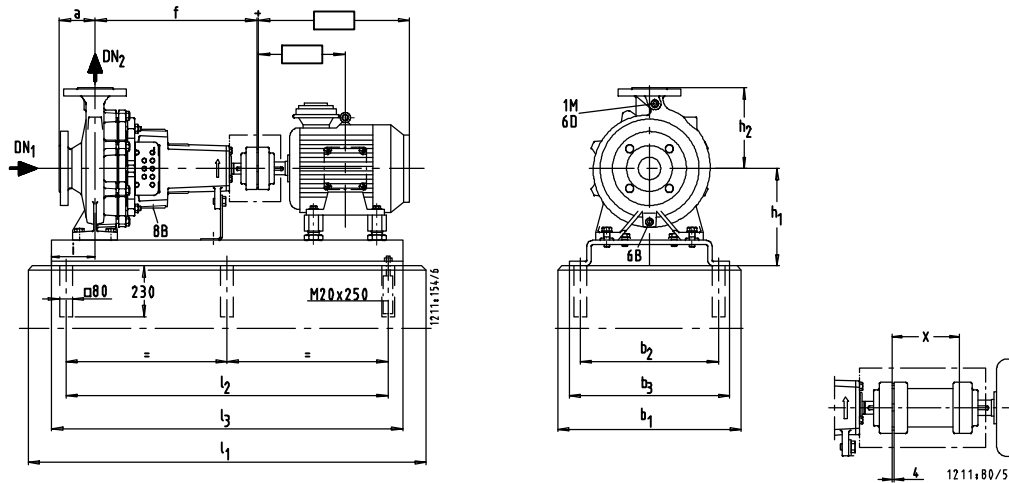


Fig. B

Etanorm	Moteur 1 / min 1450 1750 2900 3500 kW				Taille	Fig.																					
	DN ₁	DN ₂	a	b ₁			b ₂	b ₃	f	h ₁	h ₂	i	l ₁	l ₂	l ₃	l ₁	l ₂	l ₃	x								
125-200	7,5	-	-	-	132M	A	150	125	140	550	320	400	470	360	315	130	1150	940	1000	1400	1190	1250	1570	1360	1420	140	
	11,0	-	-	-	160M	A	150	125	140	550	320	400	470	360	315	130	1400	1190	1250	1570	1360	1420	140	140	140	140	
	15,0	15,0	-	-	160L	A	150	125	140	550	320	400	470	360	315	130	1400	1190	1250	1570	1360	1420	140	140	140	140	
	-	18,5	-	-	180M	A	150	125	140	550	320	400	470	360	315	130	1400	1190	1250	1570	1360	1420	140	140	140	140	
	-	22,0	-	-	180L	A	150	125	140	550	320	400	470	360	315	130	1400	1190	1250	1570	1360	1420	140	140	140	140	
	-	-	55	-	250M	B	150	125	140	810	600	650	470	390	315	130	1750	1060	1600	1750	1060	1600	140	140	140	140	
	-	-	75	-	280S	B	150	125	140	880	670	720	470	420	315	130	1750	1060	1600	1750	1060	1600	140	140	140	140	
	-	-	90	90	280M	B	150	125	140	880	670	720	470	420	315	130	1750	1060	1600	1750	1060	1600	140	140	140	140	
-	-	110	110	315S	B	150	125	140	940	730	780	470	455	315	130	1800	1100	1650	1800	1100	1650	140	140	140	140		
125-250	11,0	-	-	-	160M	A	150	125	140	550	320	400	470	360	355	130	1400	1190	1250	1570	1360	1420	140	140	140	140	
	15,0	-	-	-	160L	A	150	125	140	550	320	400	470	360	355	130	1400	1190	1250	1570	1360	1420	140	140	140	140	
	18,5	18,5	-	-	180M	A	150	125	140	550	320	400	470	360	355	130	1400	1190	1250	1570	1360	1420	140	140	140	140	
	-	22	-	-	180L	A	150	125	140	550	320	400	470	360	355	130	1400	1190	1250	1570	1360	1420	140	140	140	140	
	-	30	-	-	200L	B	150	125	140	750	550	590	470	390	355	130	1550	940	1400	1550	940	1400	140	140	140	140	
	-	37	-	-	225S	B	150	125	140	750	550	590	470	390	355	130	1550	940	1400	1550	940	1400	140	140	140	140	
125-315	18,5	-	-	-	180M	B	150	125	140	810	600	650	530	420	355	112	1750	1060	1600	1750	1060	1600	140	140	140	140	
	22	-	-	-	180L	B	150	125	140	810	600	650	530	420	355	112	1750	1060	1600	1750	1060	1600	140	140	140	140	
	30	-	-	-	200L	B	150	125	140	810	600	650	530	420	355	112	1750	1060	1600	1750	1060	1600	140	140	140	140	
	37	37	-	-	225S	B	150	125	140	810	600	650	530	420	355	112	1750	1060	1600	1750	1060	1600	140	140	140	140	
	-	45	-	-	225M	B	150	125	140	810	600	650	530	420	355	112	1750	1060	1600	1750	1060	1600	140	140	140	140	
	-	55	-	-	250M	B	150	125	140	810	600	650	530	420	355	112	1750	1060	1600	1750	1060	1600	140	140	140	140	
	-	75	-	-	280S	B	150	125	140	880	670	720	530	420	355	112	1750	1060	1600	1750	1060	1600	140	140	140	140	
	125-400	30	-	-	-	200L	B	150	125	140	810	600	650	530	455	400	112	1750	1060	1600	1750	1060	1600	140	140	140	140
37		-	-	-	225S	B	150	125	140	810	600	650	530	455	400	112	1750	1060	1600	1750	1060	1600	140	140	140	140	
45		-	-	-	225M	B	150	125	140	810	600	650	530	455	400	112	1750	1060	1600	1750	1060	1600	140	140	140	140	
55		55	-	-	250M	B	150	125	140	810	600	650	530	455	400	112	1750	1060	1600	1750	1060	1600	140	140	140	140	
75		75	-	-	280S	B	150	125	140	880	670	720	530	455	400	112	1750	1060	1600	1750	1060	1600	140	140	140	140	
-		90	-	-	280M	B	150	125	140	880	670	720	530	455	400	112	1750	1060	1600	1750	1060	1600	140	140	140	140	
-		110	-	-	315S	B	150	125	140	940	730	780	530	455	400	112	1800	1100	1650	1800	1100	1650	140	140	140	140	

Etanorm 150-200 - 150-400

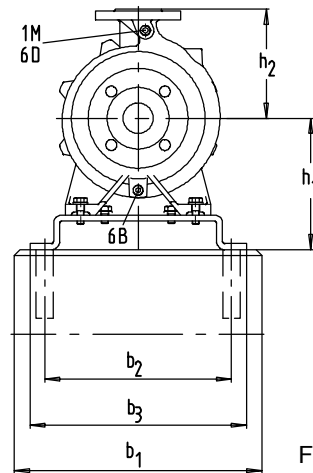
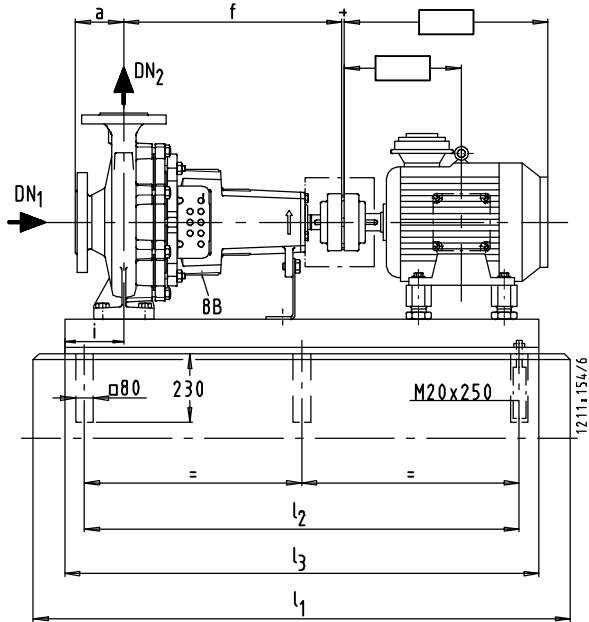
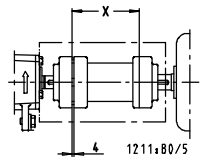


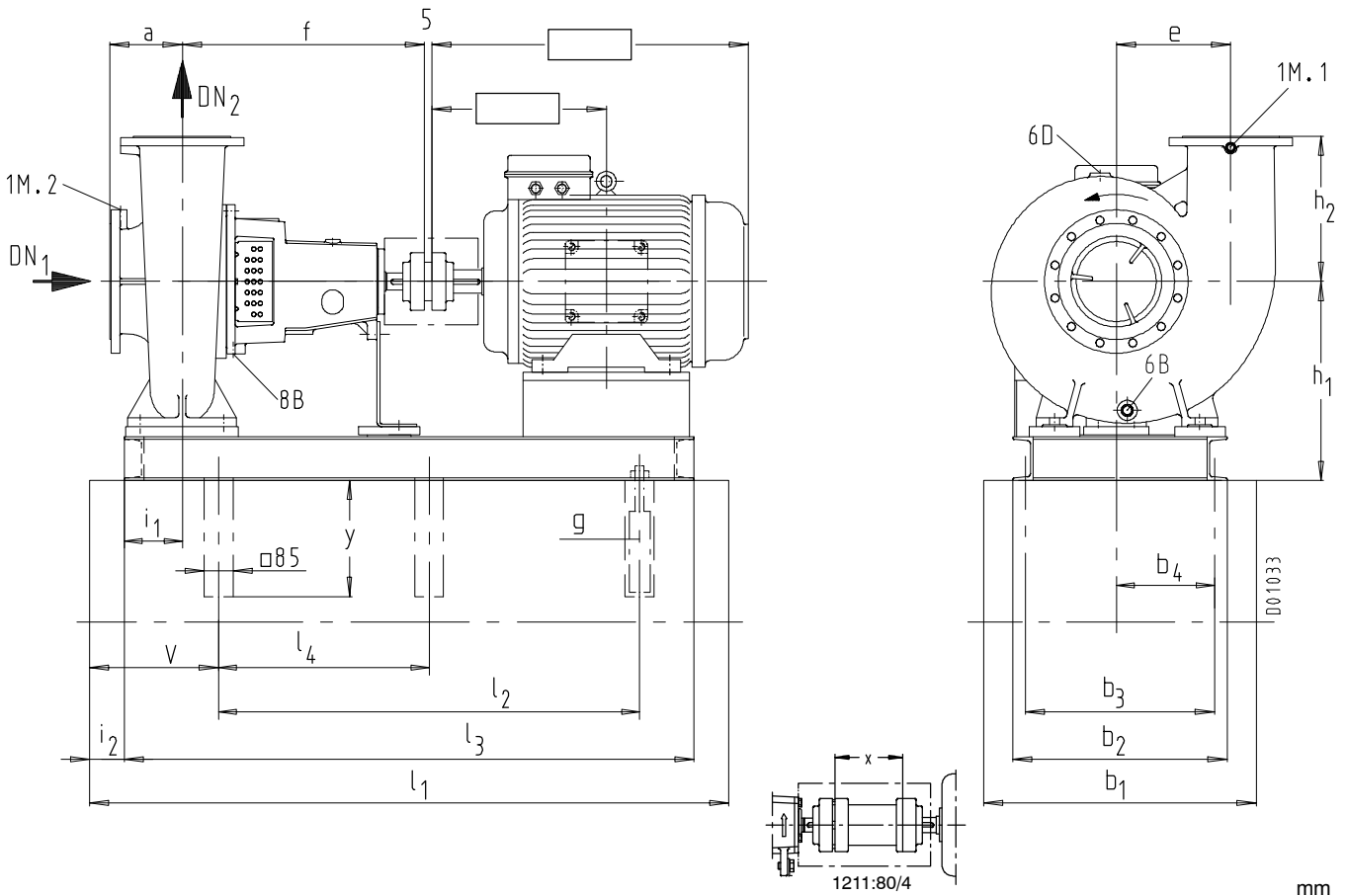
Fig. B



Etanorm	Moteur				Taille	Fig.																	
	1 / min						DN ₁	DN ₂	a	b ₁	b ₂	b ₃	f	h ₁	h ₂	i							
	1450	1750	2900	3500													kW	l ₁	l ₂	l ₃	l ₁	l ₂	l ₃
150-200	11,0	-	-	-	160M	B	200	150	160	880	670	720	470	420	400	112	1750	1060	1600	1750	1060	1600	140
	15,0	15,0	-	-	160L	B	200	150	160	880	670	720	470	420	400	112	1750	1060	1600	1750	1060	1600	140
	-	18,5	-	-	180M	B	200	150	160	880	670	720	470	420	400	112	1750	1060	1600	1750	1060	1600	140
	-	22,0	-	-	180L	B	200	150	160	880	670	720	470	420	400	112	1750	1060	1600	1750	1060	1600	140
150-250	15,0	-	-	-	160L	B	200	150	160	810	600	650	470	420	400	112	1750	1060	1600	1750	1060	1600	140
	18,5	-	-	-	180M	B	200	150	160	810	600	650	470	420	400	112	1750	1060	1600	1750	1060	1600	140
	22,0	-	-	-	180L	B	200	150	160	810	600	650	470	420	400	112	1750	1060	1600	1750	1060	1600	140
	30,0	30,0	-	-	200L	B	200	150	160	810	600	650	470	420	400	112	1750	1060	1600	1750	1060	1600	140
	-	37,0	-	-	225S	B	200	150	160	810	600	650	470	420	400	112	1750	1060	1600	1750	1060	1600	140
	-	45,0	-	-	225M	B	200	150	160	810	600	650	470	420	400	112	1750	1060	1600	1750	1060	1600	140
150-315	-	55,0	-	-	250M	B	200	150	160	810	600	650	470	420	400	112	1750	1060	1600	1750	1060	1600	140
	22	-	-	-	180L	B	200	150	160	880	670	720	530	420	400	112	1750	1060	1600	1750	1060	1600	140
	30	-	-	-	200L	B	200	150	160	880	670	720	530	420	400	112	1750	1060	1600	1750	1060	1600	140
	37	37	-	-	225S	B	200	150	160	880	670	720	530	420	400	112	1750	1060	1600	1750	1060	1600	140
	45	45	-	-	225M	B	200	150	160	880	670	720	530	420	400	112	1750	1060	1600	1750	1060	1600	140
	-	55	-	-	250M	B	200	150	160	880	670	720	530	420	400	112	1750	1060	1600	1750	1060	1600	140
150-400	-	75	-	-	280S	B	200	150	160	880	670	720	530	420	400	112	1750	1060	1600	1750	1060	1600	140
	-	90	-	-	280M	B	200	150	160	880	670	720	530	420	400	112	1750	1060	1600	1750	1060	1600	140
	37	-	-	-	225S	B	200	150	160	880	670	720	530	455	450	112	1750	1060	1600	1750	1060	1600	140
	45	-	-	-	225M	B	200	150	160	880	670	720	530	455	450	112	1750	1060	1600	1750	1060	1600	140
	55	-	-	-	250M	B	200	150	160	880	670	720	530	455	450	112	1750	1060	1600	1750	1060	1600	140
	75	75	-	-	280S	B	200	150	160	880	670	720	530	455	450	112	1750	1060	1600	1750	1060	1600	140
-	90	-	-	280M	B	200	150	160	880	670	720	530	455	450	112	1750	1060	1600	1750	1060	1600	140	
-	110	-	-	315S	B	200	150	160	940	730	780	530	455	450	112	1800	1100	1650	1800	1100	1650	140	

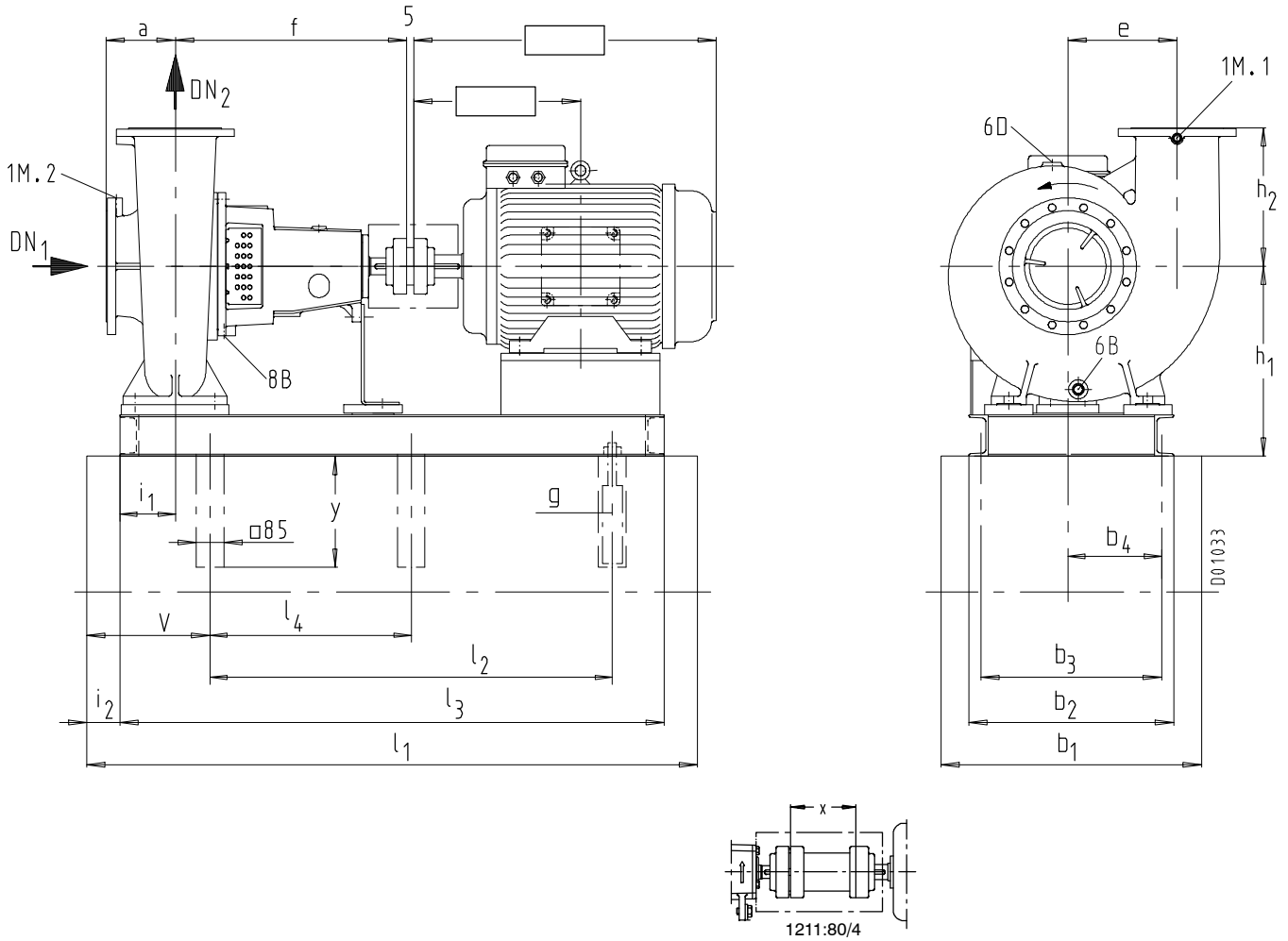
mm

Etanorm-R 200



Etanorm-R	M IP 55 960 1450 1160 1750 1/min kW	Taille																																
			1) DN1	1) DN2	a	e	f	g	h2	i1	y	b1	b2	b3	b4	h1	i2	l1	l2	l3	v	b1	b2	b3	b4	h1	i2	l1	l2	l3	l4	v	x	
200-250	4,0	--	132M	200	200	220	250	815	M20x400	345	170	450	820	570	525	293	505	115	1920	1150	1695	285	900	650	605	333	505	110	2000	1250	1780		280	200
200-250	5,5	--	132M	200	200	220	250	815	M20x400	345	170	450	820	570	525	293	505	115	1920	1150	1695	285	900	650	605	333	505	110	2000	1250	1780		280	200
200-250	7,5	--	160M	200	200	220	250	815	M20x400	345	170	450	820	570	525	293	505	115	1920	1150	1695	285	1010	760	710	385	525	110	2100	1300	1880		330	200
200-250	11,0	15,0	160L	200	200	220	250	815	M20x400	345	170	450	820	570	525	293	505	115	1920	1150	1695	285	1010	760	710	385	525	110	2100	1300	1880		330	200
200-250	--	18,5	180M	200	200	220	250	815	M20x400	345	170	450	820	570	525	293	505	115	1920	1150	1695	285	1010	760	710	385	525	110	2100	1300	1880		330	200
200-250	15,0	22,0	180L	200	200	220	250	815	M20x400	345	170	450	820	570	525	293	505	115	1920	1150	1695	285	1010	760	710	385	525	110	2100	1300	1880		330	200
200-250	--	30,0	200L	200	200	220	250	815	M20x400	345	170	450	900	650	605	333	505	110	2000	1250	1780	280	1110	860	810	435	545	110	2260	1450	2040		330	200
200-250	--	37,0	225S	200	200	220	250	815	M20x400	345	170	450	900	650	605	333	505	110	2000	1250	1780	280	1110	860	810	435	545	110	2260	1450	2040		330	200
200-250	--	45,0	225M	200	200	220	250	815	M20x400	345	170	450	900	650	605	333	505	110	2000	1250	1780	280	1110	860	810	435	545	110	2260	1450	2040		330	200
200-260	7,5	--	160M	200	200	200	300	715	M20x400	350	170	450	820	570	525	293	550	115	1920	1150	1695	285	900	650	605	333	550	110	2000	1250	1780		280	200
200-260	11,0	18,5	160L	200	200	200	300	715	M20x400	350	170	450	820	570	525	293	550	115	1920	1150	1695	285	900	650	605	333	550	110	2000	1250	1780		280	200
200-260	15,0	22,0	180L	200	200	200	300	715	M20x400	350	170	450	820	570	525	293	550	115	1920	1150	1695	285	900	650	605	333	550	110	2000	1250	1780		280	200
200-260	15,0	22,0	180L	200	200	200	300	715	M20x400	350	170	450	820	570	525	293	550	115	1920	1150	1695	285	900	650	605	333	550	110	2000	1250	1780		280	200
200-260	18,5	30,0	200L	200	200	200	300	715	M20x400	350	170	450	820	570	525	293	550	115	1920	1150	1695	285	1010	760	710	385	570	110	2100	1300	1880		330	200
200-260	--	37,0	225S	200	200	200	300	715	M20x400	350	170	450	820	570	525	293	550	115	1920	1150	1695	285	1010	760	710	385	570	110	2100	1300	1880		330	200
200-260	--	45,0	225M	200	200	200	300	715	M20x400	350	170	450	820	570	525	293	550	115	1920	1150	1695	285	1010	760	710	385	570	110	2100	1300	1880		330	200
200-260	--	55,0	250M	200	200	200	300	715	M20x400	350	170	450	900	650	605	333	550	110	2000	1250	1780	280	1110	860	810	435	590	110	2260	1450	2040		330	200
200-330	11,0	--	160L	250	200	200	315	715	M20x400	400	170	450	820	570	525	293	550	115	1920	1150	1695	285	900	650	605	333	550	110	2000	1250	1780		280	200
200-330	15,0	18,5	180M	250	200	200	315	715	M20x400	400	170	450	820	570	525	293	550	115	1920	1150	1695	285	900	650	605	333	550	110	2000	1250	1780		280	200
200-330	15,0	22,0	180L	250	200	200	315	715	M20x400	400	170	450	820	570	525	293	550	115	1920	1150	1695	285	900	650	605	333	550	110	2000	1250	1780		280	200
200-330	18,5	--	200L	250	200	200	315	715	M20x400	400	170	450	820	570	525	293	550	115	1920	1150	1695	285	1010	760	710	385	570	110	2100	1300	1880		330	200
200-330	22,0	30,0	200L	250	200	200	315	715	M20x400	400	170	450	820	570	525	293	550	115	1920	1150	1695	285	1010	760	710	385	570	110	2100	1300	1880		330	200
200-330	--	37,0	225S	250	200	200	315	715	M20x400	400	170	450	820	570	525	293	550	115	1920	1150	1695	285	1010	760	710	385	570	110	2100	1300	1880		330	200
200-330	30,0	45,0	225M	250	200	200	315	715	M20x400	400	170	450	820	570	525	293	550	115	1920	1150	1695	285	1010	760	710	385	570	110	2100	1300	1880		330	200
200-330	--	55,0	250M	250	200	200	315	715	M20x400	400	170	450	900	650	605	333	550	110	2000	1250	1780	280	1110	860	810	435	590	110	2260	1450	2040		330	200
200-330	--	75,0	280S	250	200	200	315	715	M20x400	400	170	450	900	650	605	333	550	110	2000	1250	1780	280	1110	860	810	435	590	110	2260	1450	2040		330	200
200-330	--	90,0	280M	250	200	200	315	715	M20x400	400	170	450	1010	760	710	385	570	110	2100	1300	1880	330	1110	860	810	435	590	110	2260	1450	2040		330	200
200-330	--	110,0	315S	250	200	200	315	715	M20x400	400	170	450	1010	760	710	385	570	110	2100	1300	1880	330	1110	860	810	435	590	110	2450	1650	2230	825	330	200
200-400	18,5	--	200L	250	200	180	290	715	M20x400	400	170	450	820	570	525	293	550	115	1920	1150	1695	285	1010	760	710	385	570	110	2100	1300	1880		330	200
200-400	22,0	--	200L	250	200	180	290	715	M20x400	400	170	450	820	570	525	293	550	115	1920	1150	1695	285	1010	760	710	385	570	110	2100	1300	1880		330	200
200-400	30,0	--	225M	250	200	180	290	715	M20x400	400	170	450	820	570	525	293	550	115	1920	1150	1695	285	1010	760	710	385	570	110	2100	1300	1880		330	200
200-400	37,0	--	250M	250	200	180	290	715	M20x400	400	170	450	900	650	605	333	550	110	2000	1250	1780	280	1110	860	810	435	590	110	2260	1450	2040		330	200
200-400	45,0	75,0	280S	250	200	180	290	715	M20x400	400	170	450	900	650	605	333	550	110	2000	1250	1780	280	1110	860	810	435	590	110	2260	1450	2040		330	200
200-400	55,0	90,0	280M	250	200	180	290	715	M20x400	400	170	450	1010	760	710	385	570	110	2100	1300	1880	330	1110	860	810	435	590	110	2260	1450	2040		330	200
200-400	75,0	110,0	315S	250	200	180	290	715	M20x400	400	170	450	1010	760	710	385	570	110	2100	1300	1880	330	1110	860	810	435	590	110	2450	1650	2230	825	330	200
200-400	--	132,0	315M	250	200	180	290	715	M20x400	400	170	450	1110	860	810	435	590	110	2260	1450	2040	330	1110	860	810	435	590	110	2450	1650	2230	825	330	200
200-500	30,0	--	225M	250	200	200	387	715	M20x400	450	195	450	1010	760	710	385	670	110	2000	1200	1780	330	1110	860	810	435	690	110	2100	1300	1880		330	200
200-500	37,0	--	250M	250	200	200	387	715	M20x400	450	195	450	1010	760	710	385	670	110	2000	1200	1780	330	1110	860	810	435	690	110	2260	1450	2040		330	200
200-500	45,0	--	280S	250	200	200	387	715	M20x400	450	195	450	1010	760	710	385	670	110	2100	1300	1880	330	1110	860	810	435	690	110	2260	1450	2040		330	200
200-500	55,0	--	280M	250	200	200	387	715	M20x400	450	195	450	1010	760	710	385																		

Etanorm-R 250

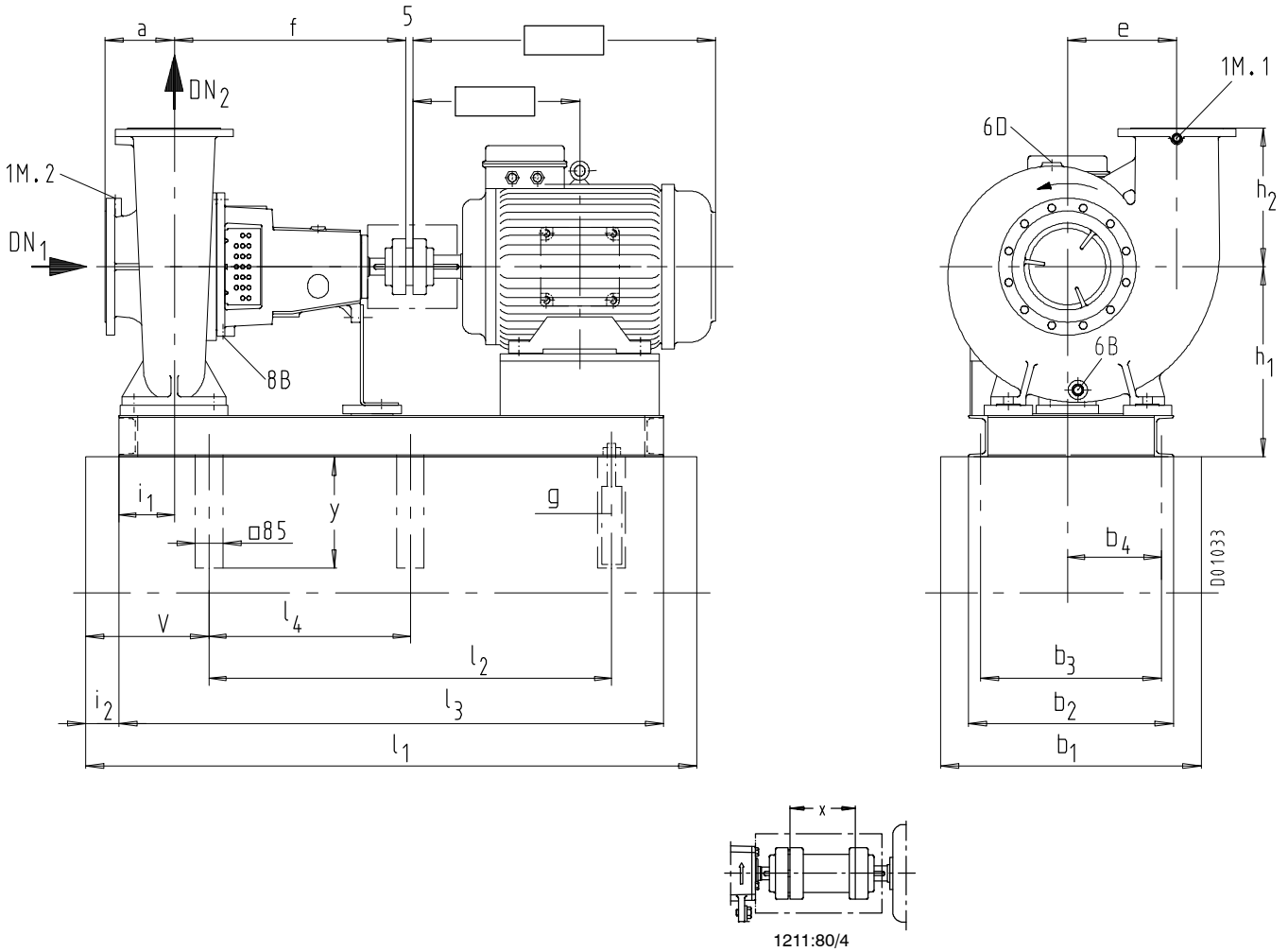


mm

Etanorm-R	M IP 55		Taille																															
	960 1160	1450 1750		1/min kW	DN ₁	DN ₂	a	e	f	g	h ₂	i ₁	y	b ₁	b ₂	b ₃	b ₄	h ₁	i ₂	l ₁	l ₂	l ₃	v	b ₁	b ₂	b ₃	b ₄	h ₁	i ₂	l ₁	l ₂	l ₃	l ₄	v
250-300	11,0	--	160L	250	250	225	300	830	M20x400	400	170	450	1010	760	710	385	570	115	1920	1150	1695	310	1010	760	710	385	570	110	2100	1300	1880		330	250
250-300	--	18,5	180M	250	250	225	300	830	M20x400	400	170	450	1010	760	710	385	570	115	1920	1150	1695	310	1010	760	710	385	570	110	2100	1300	1880		330	250
250-300	15,0	--	180L	250	250	225	300	830	M20x400	400	170	450	1010	760	710	385	570	115	1920	1150	1695	310	1110	860	810	445	590	110	2260	1450	2040		330	250
250-300	18,5	30,0	200L	250	250	225	300	830	M20x400	400	170	450	1010	760	710	385	570	110	2000	1200	1780	330	1110	860	810	445	590	110	2260	1450	2040		330	250
250-300	22,0	--	200L	250	250	225	300	830	M20x400	400	170	450	1010	760	710	385	570	110	2000	1200	1780	330	1110	860	810	445	590	110	2260	1450	2040		330	250
250-300	--	37,0	225S	250	250	225	300	830	M20x400	400	170	450	1010	760	710	385	570	110	2000	1200	1780	330	1110	860	810	445	590	110	2260	1450	2040		330	250
250-300	30,0	45,0	225M	250	250	225	300	830	M20x400	400	170	450	1010	760	710	385	570	110	2000	1200	1780	330	1110	860	810	445	590	110	2260	1450	2040		330	250
250-300	--	55,0	250M	250	250	225	300	830	M20x400	400	170	450	1010	760	710	385	570	110	2100	1300	1880	330	1110	860	800	430	610	110	2450	1650	2230	825	330	250
250-300	--	75,0	280S	250	250	225	300	830	M20x400	400	170	450	1010	760	710	385	570	110	2100	1300	1880	330	1110	860	800	430	610	110	2450	1650	2230	825	330	250
250-300	--	90,0	280M	250	250	225	300	830	M20x400	400	170	450	1110	860	810	435	590	110	2260	1450	2040	330	1110	860	800	430	610	110	2450	1650	2230	825	330	250
250-330	15,0	--	180L	250	250	250	345	715	M20x400	400	195	450	1010	760	710	395	620	115	1920	1150	1695	310	1010	760	710	395	620	110	2100	1300	1880		330	200
250-330	18,5	--	200L	250	250	250	345	715	M20x400	400	195	450	1010	760	710	395	620	115	1920	1150	1695	310	1010	760	710	395	620	110	2100	1300	1880		330	200
250-330	22,0	--	200L	250	250	250	345	715	M20x400	400	195	450	1010	760	710	395	620	115	1920	1150	1695	310	1010	760	710	395	620	110	2100	1300	1880		330	200
250-330	37,0	--	225S	250	250	250	345	715	M20x400	400	195	450	1010	760	710	395	620	110	2000	1200	1780	330	1010	760	710	395	620	110	2100	1300	1880		330	200
250-330	30,0	--	225M	250	250	250	345	715	M20x400	400	195	450	1010	760	710	395	620	110	2000	1200	1780	330	1010	760	710	395	620	110	2100	1300	1880		330	200
250-330	37,0	55,0	250M	250	250	250	345	715	M20x400	400	195	450	1010	760	710	395	620	110	2000	1200	1780	330	1110	860	810	445	640	110	2240	1450	2040		330	200
250-330	45,0	75,0	280S	250	250	250	345	715	M20x400	400	195	450	1010	760	710	395	620	110	2100	1300	1880	330	1110	860	810	445	640	110	2240	1450	2040		330	200
250-330	--	90,0	280M	250	250	250	345	715	M20x400	400	195	450	1010	760	710	395	620	110	2100	1300	1880	330	1110	860	810	445	640	110	2240	1450	2040		330	200
250-330	--	110,0	315S	250	250	250	345	715	M20x400	400	195	450	1110	860	810	445	640	110	2260	1450	2040	330	1110	860	800	440	660	110	2450	1650	2230	825	330	200
250-330	--	132,0	315M	250	250	250	345	715	M20x400	400	195	450	1110	860	810	445	640	110	2260	1450	2040	330	1110	860	800	440	660	110	2450	1650	2230	825	330	200
250-400	18,5	--	200L	300	250	180	335	715	M20x400	480	195	450	1010	760	710	385	620	115	1920	1150	1695	310	1010	760	710	385	620	110	2100	1300	1880		330	200
250-400	22,0	--	200L	300	250	180	335	715	M20x400	480	195	450	1010	760	710	385	620	115	1920	1150	1695	310	1010	760	710	385	620	110	2100	1300	1880		330	200
250-400	37,0	--	225S	300	250	180	335	715	M20x400	480	195	450	1010	760	710	385	620	110	2000	1200	1780	330	1010	760	710	385	620	110	2100	1300	1880		330	200
250-400	30,0	--	225M	300	250	180	335	715	M20x400	480	195	450	1010	760	710	385	620	110	2000	1200	1780	330	1010	760	710	385	620	110	2100	1300	1880		330	200
250-400	37,0	--	250M	300	250	180	335	715	M20x400	480	195	450	1010	760	710	385	620	110	2000	1200	1780	330	1110	860	810	435	640	110	2280	1450	2040		330	200
250-400	45,0	--	280S	300	250	180	335	715	M20x400	480	195	450	1010	760	710	385	620	110	2100	1300	1880	330	1110	860	810	435	640	110	2280	1450	2040		330	200
250-400	--	75,0	280S	300	250	180	335	715	M20x400	480	195	450	1010	760	710	385	620	110	2100	1300	1880	330	1110	860	810	435	640	110	2280	1450	2040		330	200
250-400	--	90,0	280M	300	250	180	335	715	M20x400	480	195	450	1010	760	710	385	620	110	2100	1300	1880	330	1110	860	810	435	640	110	2280	1450	2040		330	200
250-400	75,0	110,0	315S	300	250	180	335	715	M20x400	480	195	450	1110	860	810	435	640	110	2260	1450	2040	330	1110	860	800	430	660	110	2450	1650	2230	825	330	200
250-400	--	132,0	315M	300	250	180	335	715	M20x400	480	195	450	1110	860	810	435	640	110	2260	1450	2040	330	1110	860	800	430	660	110	2450	1650	2230	825	330	200
250-500	45,0	--	280S	300	250	225	425	715	M20x400	500	220	450	1110	860	810	445	690	110	2260	1450	2040	330	1110	860	810	445	690	110	2260	1450	2040		330	200
250-500	55,0	--	280M	300	250	225	425	715	M20x400	500	220	450	1110	860	810	445	690	110	2260	1450	2040	330	1110	860	800	440	710	110	2450	1650	2230	825	330	200
250-500	75,0	--	315S	300	250	225	425	715	M20x400	500	220	450	1110	860	810	445	690	110	2260	1450	2040	330	1110	860	800	440	710	110	2450	1650	2230	825	330	200
250-500	90,0	--	315M	300	250	225	425	715	M20x400	500	220	450	1110	860	810	445	690	110	2260	1450	2040	330	1110	860	800	440	710	110	2450	1650	2230	825	330	200

1) DN = EN 1092-2/DN.../PN 10/21/GJL-250/B710
 DN = EN 1092-2/DN.../PN 16/21/GJS-400-18-LT/B

Etanorm-R 300

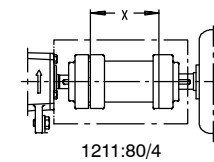
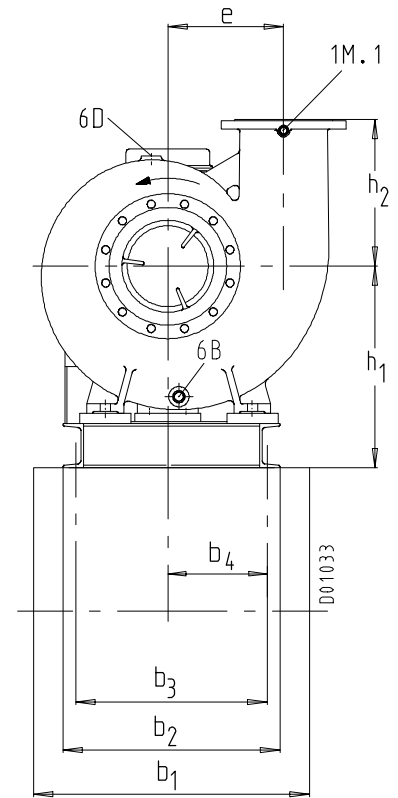
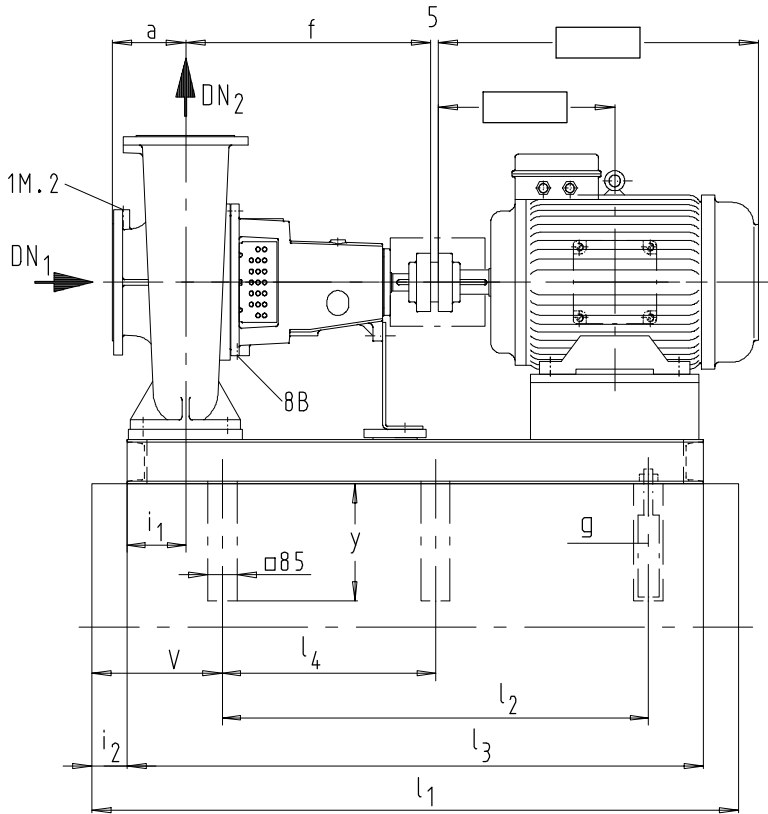


mm

Etanorm-R	M	IP 55	Taille	1)										2)																				
				DN ₁	DN ₂	a	e	f	g	h ₂	i ₁	y	b ₁	b ₂	b ₃	b ₄	h ₁	i ₂	l ₁	l ₂	l ₃	v	b ₁	b ₂	b ₃	b ₄	h ₁	i ₂	l ₁	l ₂	l ₃	l ₄	v	x
300-340	15,0	-	180L	300	300	255	315	850	M20x400	450	195	450	1010	760	710	395	620	110	2000	1200	1780	330	1110	860	810	445	640	110	2260	1450	2040		330	250
300-340	18,5	-	200L	300	300	255	315	850	M20x400	450	195	450	1010	760	710	395	620	110	2000	1200	1780	330	1110	860	810	445	640	110	2260	1450	2040		330	250
300-340	22,0	-	200L	300	300	255	315	850	M20x400	450	195	450	1010	760	710	395	620	110	2000	1200	1780	330	1110	860	810	445	640	110	2260	1450	2040		330	250
300-340	-	37,0	225S	300	300	255	315	850	M20x400	450	195	450	1010	760	710	395	620	110	2000	1200	1780	330	1110	860	810	445	640	110	2260	1450	2040		330	250
300-340	30,0	45,0	225M	300	300	255	315	850	M20x400	450	195	450	1010	760	710	395	620	110	2000	1200	1780	330	1110	860	800	440	660	110	2450	1650	2230		330	250
300-340	30,0	55,0	250M	300	300	255	315	850	M20x400	450	195	450	1010	760	710	395	620	110	2000	1200	1780	330	1110	860	800	440	660	110	2450	1650	2230	825	330	250
300-340	37,0	-	250M	300	300	255	315	850	M20x400	450	195	450	1010	760	710	395	620	110	2100	1300	1880	330	1110	860	800	440	660	110	2450	1650	2230	825	330	250
300-340	45,0	75,0	280S	300	300	255	315	850	M20x400	450	195	450	1110	860	810	445	640	110	2260	1450	2040	330	1110	860	800	440	660	110	2450	1650	2230	825	330	250
300-340	-	90,0	280M	300	300	255	315	850	M20x400	450	195	450	1110	860	810	445	640	110	2260	1450	2040	330	1110	860	800	440	660	110	2450	1650	2230	825	330	250
300-340	-	110,0	315S	300	300	255	315	850	M20x400	450	195	450	1110	860	810	445	640	110	2260	1450	2040	330	1110	860	800	440	660	110	2590	1800	2370	900	330	250
300-340	-	132,0	315M	300	300	255	315	850	M20x400	450	195	450	1110	860	800	440	660	110	2450	1650	2230	330	1110	860	800	440	660	110	2590	1800	2370	900	330	250
300-360	30,0	-	225M	300	300	300	387	717	M20x400	450	220	450	1010	760	710	395	730	110	2000	1200	1780	330	1110	860	810	445	750	110	2260	1450	2040		330	250
300-360	37,0	-	250M	300	300	300	387	717	M20x400	450	220	450	1010	760	710	395	730	110	2100	1300	1880	330	1110	860	810	445	750	110	2250	1450	2040		330	250
300-360	45,0	-	280S	300	300	300	387	717	M20x400	450	220	450	1010	760	710	395	730	110	2100	1300	1880	330	1110	860	800	440	750	110	2450	1650	2230	825	330	250
300-360	55,0	90,0	280M	300	300	300	387	717	M20x400	450	220	450	1010	760	710	395	730	110	2100	1300	1880	330	1110	860	800	440	750	110	2450	1650	2230	825	330	250
300-360	75,0	110,0	315S	300	300	300	387	717	M20x400	450	220	450	1110	860	810	445	750	110	2260	1450	2040	330	1110	860	800	440	750	110	2450	1650	2230	825	330	250
300-360	-	132,0	315M	300	300	300	387	717	M20x400	450	220	450	1110	860	810	445	750	110	2260	1450	2040	330	1110	860	800	440	750	110	2450	1650	2230	825	330	250
300-400	37,0	-	250M	350	300	300	425	715	M20x400	500	220	450	1110	860	810	455	750	110	2260	1450	2040	330	1110	860	810	455	750	110	2260	1450	2040		330	250
300-400	45,0	-	280S	350	300	300	425	715	M20x400	500	220	450	1110	860	810	455	750	110	2260	1450	2040	330	1110	860	800	450	770	110	2450	1650	2230	825	330	250
300-400	55,0	-	280M	350	300	300	425	715	M20x400	500	220	450	1110	860	810	455	750	110	2260	1450	2040	330	1110	860	800	450	770	110	2450	1650	2230	825	330	250
300-400	75,0	-	315S	350	300	300	425	715	M20x400	500	220	450	1110	860	810	455	750	110	2260	1450	2040	330	1110	860	800	450	770	110	2450	1650	2230	825	330	250
300-400	-	110,0	315S	350	300	300	425	715	M20x400	500	220	450	1110	860	810	455	750	110	2260	1450	2040	330	1110	860	800	450	770	110	2450	1650	2230	825	330	250
300-400	90,0	132,0	315M	350	300	300	425	715	M20x400	500	220	450	1110	860	810	455	750	110	2260	1450	2040	330	1110	860	800	450	770	110	2450	1650	2230	825	330	250
300-500	75,0	-	315S	350	300	300	450	715	M20x400	500	220	450	1110	860	810	455	750	110	2260	1450	2040	330	1110	860	800	450	770	110	2450	1650	2230	825	330	250
300-500	75,0	-	315M	350	300	300	450	715	M20x400	500	220	450	1110	860	810	455	750	110	2260	1450	2040	330	1110	860	800	450	770	110	2450	1650	2230	825	330	250

1) DN = EN 1092-2/DN.../PN 10/21/GJL-250/B710
 DN = EN 1092-2/DN.../PN 16/21/GJS-400-18-LT/B

Etanorm-R 125-500/2 - 150-500.1

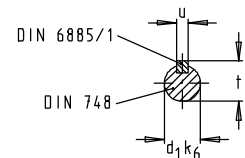
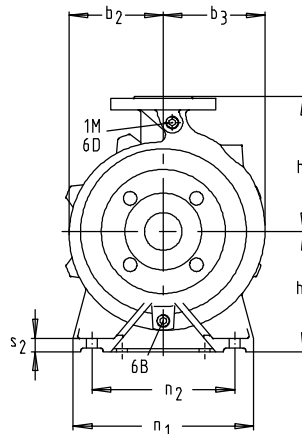
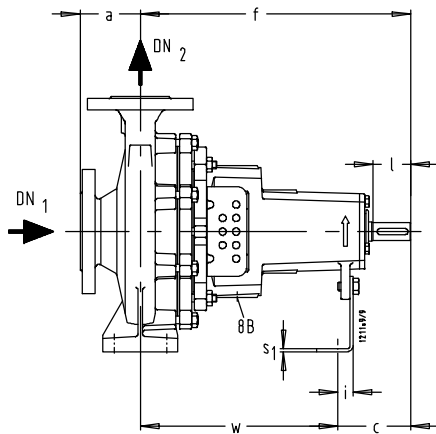


mm

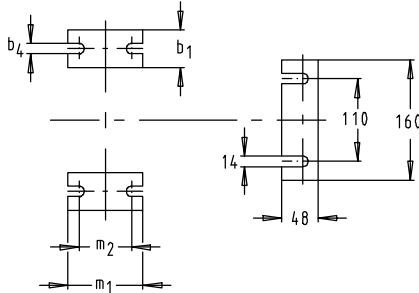
Etanorm-R	IP 55		Taille	mm																	mm																
	960 1160	1450 1750		1) DN ₁	1) DN ₂	a	e	f	g	h ₂	i	y	b ₁	b ₂	b ₃	b ₄	h ₁	i ₂	l ₁	l ₂	l ₃	v	b ₁	b ₂	b ₃	b ₄	h ₁	i ₂	l ₁	l ₂	l ₃	l ₄	v	x			
125-500/2	11,0	-	160L	150	125	245	270	703	M20x400	300	145	450	1010	760	710	370	525	115	1920	1150	1695	310	1010	760	710	370	525	115	1920	1150	1695	310	200	200			
125-500/2	18,5	-	180M	150	125	245	270	703	M20x400	300	145	450	1010	760	710	370	525	115	1920	1150	1695	310	1010	760	710	370	525	115	1920	1150	1695	310	200	200			
125-500/2	15,0	-	180L	150	125	245	270	703	M20x400	300	145	450	1010	760	710	370	525	115	1920	1150	1695	310	900	650	805	318	505	110	2000	1250	1780	280	200	200			
125-500/2	18,5	-	200L	150	125	245	270	703	M20x400	300	145	450	1010	760	710	370	525	115	1920	1150	1695	310	1010	760	710	370	525	110	2100	1300	1880	330	200	200			
125-500/2	22,0	-	200L	150	125	245	270	703	M20x400	300	145	450	1010	760	710	370	525	115	1920	1150	1695	310	1010	760	710	370	525	110	2100	1300	1880	330	200	200			
125-500/2	-	30,0	200L	150	125	245	270	703	M20x400	300	145	450	1010	760	710	370	525	115	1920	1150	1695	310	1010	760	710	370	525	110	2100	1300	1880	330	200	200			
125-500/2	-	37,0	225S	150	125	245	270	703	M20x400	300	145	450	1010	760	710	370	525	115	1920	1150	1695	310	1010	760	710	370	525	110	2100	1300	1880	330	200	200			
125-500/2	30,0	45,0	225M	150	125	245	270	703	M20x400	300	145	450	1010	760	710	370	525	115	1920	1150	1695	310	1010	760	710	370	525	110	2100	1300	1880	330	200	200			
125-500/2	37,0	55,0	250M	150	125	245	270	703	M20x400	300	145	450	1010	760	710	370	525	115	1920	1150	1695	310	1010	760	710	370	525	110	2100	1300	1880	330	200	200			
125-500/2	45,0	75,0	280S	150	125	245	270	703	M20x400	300	145	450	900	650	605	318	505	110	2000	1250	1780	280	1110	860	810	420	545	110	2260	1450	2040	330	200	200			
125-500/2	55,0	90,0	280M	150	125	245	270	703	M20x400	300	145	450	900	650	605	318	505	110	2000	1250	1780	280	1110	860	810	420	545	110	2260	1450	2040	330	200	200			
150-500.1	18,5	-	200L	200	150	150	315	715	M20x400	450	170	450	820	570	525	272	550	115	1920	1150	1695	285	1010	760	710	365	570	110	2100	1300	1880	330	200	200			
150-500.1	22,0	-	200L	200	150	150	315	715	M20x400	450	170	450	820	570	525	272	550	115	1920	1150	1695	285	1010	760	710	365	570	110	2100	1300	1880	330	200	200			
150-500.1	37,0	-	225S	200	150	150	315	715	M20x400	450	170	450	820	570	525	272	550	115	1920	1150	1695	285	1010	760	710	365	570	110	2100	1300	1880	330	200	200			
150-500.1	30,0	-	225M	200	150	150	315	715	M20x400	450	170	450	820	570	525	272	550	115	1920	1150	1695	285	1010	760	710	365	570	110	2100	1300	1880	330	200	200			
150-500.1	37,0	-	250M	200	150	150	315	715	M20x400	450	170	450	900	650	605	313	550	110	2000	1250	1780	280	1110	860	810	415	590	110	2260	1450	2040	330	200	200			
150-500.1	45,0	-	280S	200	150	150	315	715	M20x400	450	170	450	900	650	605	313	550	110	2000	1250	1780	280	1110	860	810	415	590	110	2260	1450	2040	330	200	200			
150-500.1	-	75,0	280S	200	150	150	315	715	M20x400	450	170	450	900	650	605	313	550	110	2000	1250	1780	280	1110	860	810	415	590	110	2260	1450	2040	330	200	200			
150-500.1	55,0	90,0	280M	200	150	150	315	715	M20x400	450	170	450	1010	760	710	365	570	110	2100	1300	1880	330	1110	860	810	415	590	110	2260	1450	2040	330	200	200			
150-500.1	75,0	110,0	315S	200	150	150	315	715	M20x400	450	170	450	1010	760	710	365	570	110	2100	1300	1880	330	1110	860	800	410	610	110	2450	1650	2230	825	330	200			
150-500.1	-	132,0	315M	200	150	150	315	715	M20x400	450	170	450	1110	860	810	415	590	110	2260	1450	2040	330	1110	860	800	410	610	110	2450	1650	2230	825	330	200			

1) DN = EN 1092-2/DN.../PN 10/21/GJL-250/B710
 DN = EN 1092-2/DN.../PN 16/21/GJS-400-18-LT/B

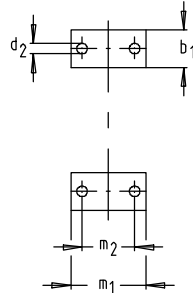
Etanorm



Etanorm G, M, S, B



Etanorm C



	DN 32-150	DN 200
Etanorm G, M	EN 1092-2/ PN 16/21/JL 1040/B	
Etanorm S	EN 1092-2/PN 16/21/JS 1025/B	
Etanorm B	ISO 7005-3/ PN 10/ 21	
Etanorm C	EN 1092-1	
	PN 16/21	PN 10/21

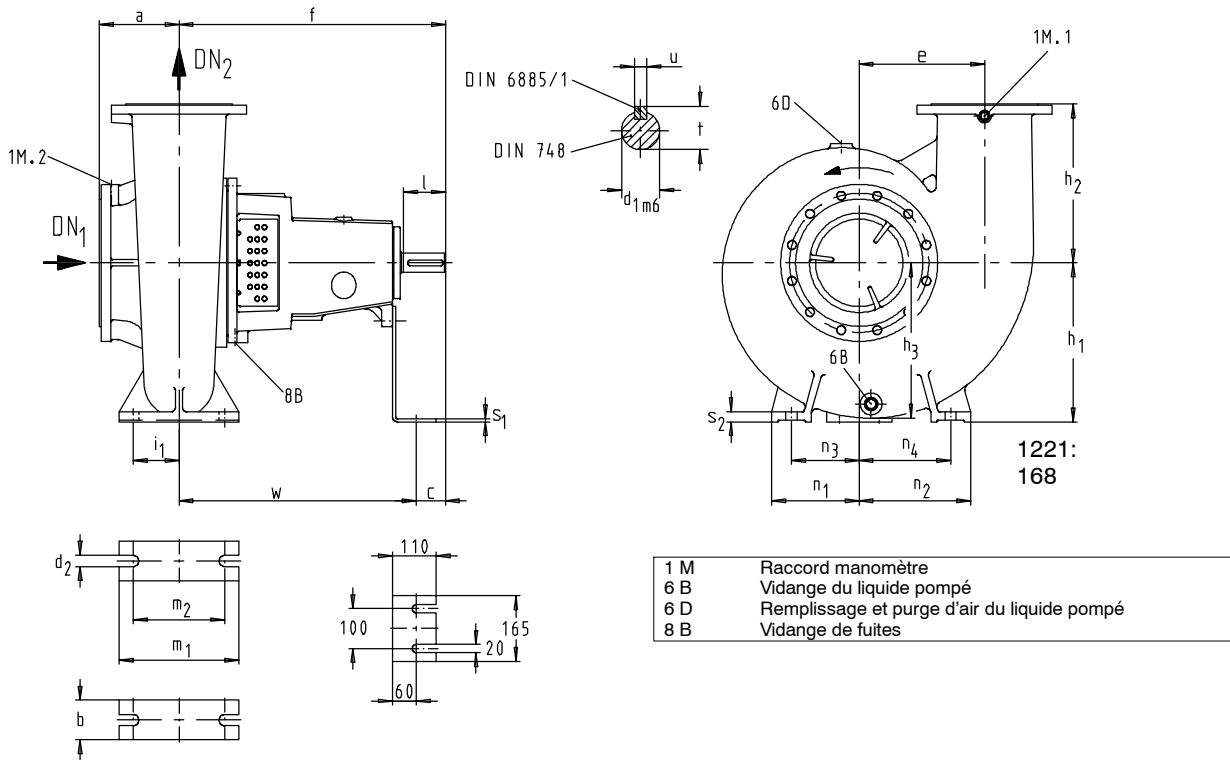
1 M Raccord manomètre
 6 B Vidange du liquide pompé
 6 D Remplissage et purge d'air du liquide pompé
 8 B Vidange de fuites

mm

Etanorm	DN ₁	DN ₂	a	b ₁	b ₂	b ₃	b ₄	c	d ₁ k ₆	d ₂	f	h ₁	h ₂	i	l	m ₁	m ₂	n ₁	n ₂	s ₁	s ₂	t	u	w	Etanorm			
																									G, M, B		S, C	
																									1) 1 M 6 B 6 D	2) 8 B	2) 1 M 6 B 6 D	2) 8 B
32-125.1	50	32	80	50	113	113	14	100	24	-	360	112	140	23	50	100	70	190	140	4	15	27	8	260	Rc 3/8	G 1/2	G 3/8	G 1/2
32-160.1	50	32	80	50	116	125	14	100	24	14	360	132	160	23	50	100	70	240	190	4	15	27	8	260	Rc 3/8	G 1/2	G 3/8	G 1/2
32-200.1	50	32	80	50	128	137	14	100	24	14	360	160	180	25	50	100	70	240	190	6	18	27	8	260	Rc 3/8	G 1/2	G 3/8	G 1/2
32-250.1	50	32	100	65	164	171	14	100	24	14	360	180	225	25	50	125	95	320	250	6	18	27	8	260	Rc 3/8	G 1/2	G 3/8	G 1/2
32-125	50	32	80	50	113	113	14	100	24	14	360	112	140	23	50	100	70	190	140	4	15	27	8	260	Rc 3/8	G 1/2	G 3/8	G 1/2
32-160	50	32	80	50	113	125	14	100	24	14	360	132	160	23	50	100	70	240	190	4	15	27	8	260	Rc 3/8	G 1/2	G 3/8	G 1/2
32-200	50	32	80	50	132	141	14	100	24	14	360	160	180	25	50	100	70	240	190	6	18	27	8	260	Rc 3/8	G 1/2	G 3/8	G 1/2
32-250	50	32	100	65	170	176	14	100	24	14	360	180	225	25	50	125	95	320	250	6	18	27	8	260	Rc 3/8	G 1/2	G 3/8	G 1/2
40-125	65	40	80	50	113	113	14	100	24	14	360	112	140	23	50	100	70	210	160	4	15	27	8	260	Rc 3/8	G 1/2	G 3/8	G 1/2
40-160	65	40	80	50	115	131	14	100	24	14	360	132	160	23	50	100	70	240	190	4	15	27	8	260	Rc 3/8	G 1/2	G 3/8	G 1/2
40-200	65	40	100	50	115	131	14	100	24	14	360	160	180	25	50	100	70	265	212	6	18	27	8	260	Rc 3/8	G 1/2	G 3/8	G 1/2
40-250	65	40	100	65	165	178	14	100	24	14	360	180	225	25	50	125	95	320	250	6	18	27	8	260	Rc 3/8	G 1/2	G 3/8	G 1/2
40-315	65	40	125	65	194	203	14	130	32	14	470	225	250	24	80	125	95	345	280	6	18	35	10	340	Rc 3/8	G 1/2	G 3/8	G 1/2
50-125	65	50	100	50	113	128	14	100	24	14	360	132	160	23	50	100	70	240	190	4	18	27	8	260	Rc 3/8	G 1/2	G 3/8	G 1/2
50-160	65	50	100	50	126	147	14	100	24	14	360	160	180	25	50	100	70	265	212	6	18	27	8	260	Rc 3/8	G 1/2	G 3/8	G 1/2
50-200	65	50	100	50	145	165	14	100	24	14	360	160	200	25	50	100	70	265	212	6	18	27	8	260	Rc 3/8	G 1/2	G 3/8	G 1/2
50-250	65	50	100	65	168	184	14	100	24	14	360	180	225	25	50	125	95	320	250	6	18	27	8	260	Rc 3/8	G 1/2	G 3/8	G 1/2
50-315	65	50	125	65	200	216	14	130	32	14	470	225	280	24	80	125	95	345	280	6	18	35	10	340	Rc 3/8	G 1/2	G 3/8	G 1/2
65-125	80	65	100	65	120	148	14	100	24	14	360	160	180	25	50	125	95	280	212	6	18	27	8	260	Rc 3/8	G 1/2	G 3/8	G 1/2
65-160	80	65	100	65	130	158	14	100	24	14	360	160	200	25	50	125	95	280	212	6	18	27	8	260	Rc 3/8	G 1/2	G 3/8	G 1/2
65-200	80	65	100	65	154	177	14	100	24	14	360	180	225	25	50	125	95	320	250	6	18	27	8	260	Rc 3/8	G 1/2	G 3/8	G 1/2
65-250	80	65	100	80	180	200	19	130	32	18	470	200	250	24	80	160	120	360	280	6	20	35	10	340	Rc 3/8	G 1/2	G 3/8	G 1/2
65-315	80	65	125	80	208	229	19	130	32	18	470	225	280	24	80	160	120	400	315	6	20	35	10	340	Rc 3/8	G 1/2	G 3/8	G 1/2
80-160	100	80	125	65	153	192	14	100	24	14	360	180	225	25	50	125	95	320	250	6	18	27	8	260	Rc 3/8	G 1/2	G 3/8	G 1/2
80-200	100	80	125	65	161	189	14	130	32	14	470	180	250	24	80	125	95	345	280	6	18	35	10	340	Rc 3/8	G 1/2	G 3/8	G 1/2
80-250	100	80	125	80	184	210	19	130	32	18	470	200	280	24	80	160	120	400	315	6	18	35	10	340	Rc 3/8	G 1/2	G 3/8	G 1/2
80-315	100	80	125	80	220	244	19	130	32	18	470	250	315	24	80	160	120	400	315	6	20	35	10	340	Rc 3/8	G 1/2	G 3/8	G 1/2
80-400	100	80	125	80	253	276	19	160	42	18	530	280	355	25	110	160	120	435	355	6	20	45	12	370	Rc 3/8	G 1/2	G 3/8	G 1/2
100-160	125	100	125	80	178	225	19	130	32	18	470	200	280	24	80	160	120	360	280	6	18	35	10	340	Rc 1/2	G 1/2	G 1/2	G 1/2
100-200	125	100	125	80	173	213	19	130	32	18	470	200	280	24	80	160	120	360	280	6	18	35	10	340	Rc 1/2	G 1/2	G 1/2	G 1/2
100-250	125	100	140	80	190	220	19	130	32	18	470	225	280	24	80	160	120	400	315	6	18	35	10	340	Rc 1/2	G 1/2	G 1/2	G 1/2
100-315	125	100	140	80	225	255	19	130	32	18	470	250	315	24	80	160	120	400	315	6	18	35	10	340	Rc 1/2	G 1/2	G 1/2	G 1/2
100-400	125	100	140	100	253	280	24	160	42	26	530	280	355	25	110	200	150	500	400	6	20	45	12	370	Rc 1/2	G 1/2	G 1/2	G 1/2
125-200	150	125	140	80	195	244	19	130	32	18	470	250	315	24	80	160	120	400	315	6	20	35	10	340	Rc 1/2	G 1/2	G 1/2	G 1/2
125-250	150	125	140	80	226	275	19	130	32	18	470	250	355	24	80	160	120	400	315	6	20	35	10	340	Rc 1/2	G 1/2	G 1/2	G 1/2
125-315	150	125	140	100	238	278	24	160	42	23	530	280	355	25	110	200	150	500	400	6	20	35	12	370	Rc 1/2	G 1/2	G 1/2	G 1/2
125-400	150	125	140	100	275	306	24	160	42	23	530	315	400	25	110	200	150	500	400	6	20	45	12	370	Rc 1/2	G 1/2	G 1/2	G 1/2
150-200	200	150	160	100	238	315	24	130	32	23	470	280	400	24	80	200	150	550	450	6	20	35	10	340	Rc 1/2	G 1/2	G 1/2	G 1/2
150-250	200	150	160	100	228	298	24	130	32	23	470	280	400	24	80	200	150	500	400	6	20	35	10	340	Rc 1/2	G 1/2	G 1/2	G 1/2
150-315	200	150	160	100	255	303	24	160	42	23	530	280	400	25	110	200	150	550	450	6	20	45	12	370	Rc 1/2	G 1/2	G 1/2	G 1/2
150-400	200	150	160	100	285	325	24	160	42	23	530	315	450	25	110	200	150	550	450	6	20	45	12	370	Rc 1/2	G 1/2	G 1/2	G 1/2

1) Rc = ISO 7/1
2) G = ISO 228/1

Etanorm-R



- | | |
|-----|---|
| 1 M | Raccord manomètre |
| 6 B | Vidange du liquide pompé |
| 6 D | Remplissage et purge d'air du liquide pompé |
| 8 B | Vidange de fuites |

mm

Etanorm-R	DN ₁ ¹⁾	DN ₂ ¹⁾	a	b	c	d _{1m6}	d ₂	e	f	h ₁	h ₂	h ₃	i ₁	l	m ₁	m ₂	n ₁	n ₂	n ₃	n ₄	s ₁	s ₂	t	u	w
125-500/2	150	125	245	120	121	60	24	270	703	355	300	297	95	140	250	190	270	300	220	250	6	22	64	18	582
150-500.1	200	150	150	100	115	60	28	315	715	400	450	359	115	140	300	230	240	260	190	210	6	25	64	18	600
200-250	200	200	220	100	119	60	28	250	815	355	345	329	109	140	300	230	220	280	170	230	6	25	64	18	690
200-260	200	200	200	100	120	60	28	300	715	400	350	369	115	140	300	230	220	280	170	230	8	25	64	18	595
200-330	250	200	200	100	120	60	28	315	715	400	400	390	115	140	300	230	220	280	170	230	8	25	64	18	595
200-400	250	200	180	130	120	60	28	290	715	400	400	358	115	140	300	230	220	280	155	215	8	25	64	18	595
200-500	250	200	200	130	115	60	28	387	715	500	450	497	140	140	350	280	320	380	255	315	20	25	64	18	600
250-300	250	250	225	130	115	60	28	300	830	400	400	384	95	140	300	230	270	330	205	265	8	25	64	18	695
250-330	250	250	250	130	120	60	34	345	715	450	400	445	140	140	350	280	310	390	245	325	10	25	64	18	595
250-400	300	250	180	130	120	60	34	335	715	450	480	400	140	140	350	280	320	380	255	315	10	25	64	18	595
250-500	300	250	225	130	115	60	34	425	715	500	500	514	162,5	140	400	325	360	440	295	375	20	32	64	18	600
300-340	300	300	255	160	115	60	34	315	850	450	450	427	120	140	350	280	310	390	230	310	10	25	64	18	715
300-360	300	300	300	160	122	60	34	387	717	560	450	505	162,5	140	400	325	310	390	230	310	20	32	64	18	595
300-400	350	300	300	160	120	60	34	425	715	560	500	540	162,5	140	400	325	350	450	270	370	20	32	64	18	595
300-500	350	300	300	160	115	60	34	450	715	560	500	581	162,5	140	400	325	350	450	270	370	20	32	64	18	600

1) DN 125, 150 = EN 1092-2/DN.../PN 16/21/GJL-250/B
 DN 200, 250, 300, 350 = EN 1092-2/DN.../PN 10/21/GJL-250/B
 DN = EN 1092-2/DN.../PN 16/21/GJS-400-18-LT/B

Etanorm
Interchangeabilité des composants de pompe entre les gammes Etanorm et Etabloc et des composants de la gamme Etanorm

Etanorm	Unités d'arbre	Désignation											
		Volute	Fond de refoulement -Garniture de presse-étoupe	Fond de refoulement -Garniture mécanique	Arbre	Roue	Roulement à billes gorge profonde	Garniture mécanique	Garniture de presse-étoupe	Bague d'usure côté aspiration	Bague d'usure côté refoulement	Chemise d'arbre	Chemise de protection d'arbre
		Repère											
		102	163.1	163.2	210	230	321	433	461	502.1	502.2	523	524
32-125.1	25	○	1	12	1	○	1	1	1	1	X	1	1
32-160.1	25	○	1	12	1	1	1	1	1	1	3	1	1
32-200.1	25	○	4	15	1	2	1	1	1	1	3	1	1
32-250.1	25	○	6	17	1	3	1	1	1	1	4	1	1
32-125	25	○	1	12	1	○	1	1	1	1	X	1	1
32-160	25	○	1	12	1	1	1	1	1	1	3	1	1
32-200	25	○	4	15	1	2	1	1	1	1	3	1	1
32-250	25	○	6	17	1	3	1	1	1	1	4	1	1
40-125	25	○	1	12	1	○	1	1	1	2	X	1	1
40-160	25	○	1	12	1	○	1	1	1	2	3	1	1
40-200	25	○	4	15	1	○	1	1	1	○	3	1	1
40-250	25	○	6	17	1	○	1	1	1	2	4	1	1
40-315	35	○	○	○	2	○	2	2	2	2	13	2	2
50-125	25	○	1	12	1	○	1	1	1	3	3	1	1
50-160	25	○	1	12	1	○	1	1	1	3	3	1	1
50-200	25	○	4	15	1	○	1	1	1	3	3	1	1
50-250	25	○	6	17	1	○	1	1	1	3	4	1	1
50-315	35	○	9	20	2	○	2	2	2	5	10	2	2
65-125	25	○	1	12	1	○	1	1	1	5	3	1	1
65-160	25	○	2	13	1	○	1	1	1	5	9	1	1
65-200	25	○	○	○	1	○	1	1	1	5	9	1	1
65-250	35	○	○	○	2	○	2	2	2	9	13	2	2
65-315	35	○	9	20	2	○	2	2	2	9	10	2	2
80-160	25	○	2	13	1	○	1	1	1	6	9	1	1
80-200	35	○	3	14	2	○	2	2	2	6	10	2	2
80-250	35	○	7	18	2	○	2	2	2	6	10	2	2
80-315	35	○	9	20	2	○	2	2	2	6	10	2	2
80-400	55	○	11	22	3	○	3	3	3	10	8	3	3
100-160	35	○	3	14	2	○	2	2	2	7	10	2	2
100-200	35	○	3	14	2	○	2	2	2	7	10	2	2
100-250	35	○	7	18	2	○	2	2	2	7	10	2	2
100-315	35	○	9	20	2	○	2	2	2	7	10	2	2
100-400	55	○	11	22	3	○	3	3	3	7	8	3	3
125-200	35	○	5	16	2	○	2	2	2	8	11	2	2
125-250	35	○	8	19	2	○	2	2	2	8	14	2	2
125-315	55	○	10	21	3	○	3	3	3	8	8	3	3
125-400	55	○	11	22	3	○	3	3	3	8	8	3	3
150-200	35	○	5	16	2	○	2	2	2	○	11	2	2
150-250	35	○	8	19	2	○	2	2	2	12	14	2	2
150-315	55	○	10	21	3	○	3	3	3	12	8	3	3
150-400	55	○	11	22	3	○	3	3	3	12	8	3	3

1 Chiffre identique = ○ Composants différents X Composant n'existe pas
 1 Composant identique
 Composant interchangeable avec composant Etabloc

Etanorm-R
Interchangeabilité des composants de pompe

Etanorm-R	Unités d'arbre	Teile-Benennung															
		Volute	Arbre	Roue	Roulement à billes gorge profonde	Bague etancheite	Garniture mécanique	Couvercle corps	Garniture de presse-étoupe	Bague	Bague	Bague d'usure côté aspiration	Bague d'usure côté refoulement	Deflecteur	Chemise d'arbre	Chemise de protection d'arbre	Entrtoise
		102	210	230	321	421	433	161	461	500.1	500.3	502.1	502.2	507	523	524	525
125-500/2	65	○	○	○	1	1	1	○	1	1	1	○	○	1	○	○	○
150-500.1	65	○	1	○	1	1	1	1	1	1	1	1	1	1	1	1	x
200-250	65	○	2	○	1	1	1	○	1	1	1	○	3	1	2	2	x
200-260	65	○	1	○	1	1	1	○	1	1	1	1	3	1	1	1	x
200-330	65	○	1	○	1	1	1	4	1	1	1	○	4	1	1	1	x
200-400	65	○	1	○	1	1	1	○	1	1	1	2	2	1	1	1	x
200-500	65	○	1	○	1	1	1	1	1	1	1	○	1	1	1	1	x
250-300	65	○	2	○	1	1	1	4	1	1	1	○	4	1	2	2	x
250-330	65	○	1	○	1	1	1	○	1	1	1	2	4	1	1	1	x
250-400	65	○	1	○	1	1	1	○	1	1	1	○	1	1	1	1	x
250-500	65	○	1	○	1	1	1	2	1	1	1	○	1	1	1	1	x
300-340	65	○	2	○	1	1	1	○	1	1	1	○	2	1	2	2	x
300-360	65	○	1	○	1	1	1	3	1	1	1	○	1	1	1	1	x
300-400	65	○	1	○	1	1	1	3	1	1	1	3	1	1	1	1	x
300-500	65	○	1	○	1	1	1	2	1	1	1	3	1	1	1	1	x

 Composants différents

1
1

Chiffre identique = Composant identique

 Composant n'existe pas

Etanorm
Pièces de rechange recommandées pour un service continu de deux ans selon DIN 24 296

Repère	Désignation	Nombre de pompes (y compris pompes de réserve)						
		2	3	4	5	6 et 7	8 et 9	10 et plus
Pour version avec garniture mécanique		Quantité des pièces de réserve						
210	Arbre	1	1	1	2	2	2	20 %
230	Roue (y compris bague d'usure 502.2)	1	1	1	2	2	2	20 %
321	Roulement à billes à gorge profonde	2	2	4	4	6	8	100 %
330	Support de palier	-	-	-	-	-	1	2 pièces
412	Joint torique	4	6	8	8	9	10	100 %
433	Garniture mécanique	1	1	2	2	2	3	25 %
523	Chemise d'arbre	1	1	2	2	2	3	25 %
-	Joints plats (jeu)	4	6	8	8	9	12	150 %
Pour version avec garniture de presse-étoupe		Quantité des pièces de réserve						
461	Garniture de presse-étoupe (jeu)	4	4	6	6	6	8	100 %
524	Chemise de protection d'arbre	2	2	2	3	3	4	50 %
								pièces supprimées 412, 433, 523

Etanorm-R
Pièces de rechange recommandées pour un service continu de deux ans selon DIN 24 296

Repère	Désignation	Nombre de pompes (y compris pompes de réserve)						
		2	3	4	5	6 et 7	8 et 9	10 et plus
Pour version avec garniture mécanique		Quantité des pièces de réserve						
171	Defuseur ¹⁾	1	1	1	2	2	2	20 %
210	Arbre	1	1	1	2	2	2	20 %
230	Roue ²⁾	1	1	1	2	2	2	20 %
321	Roulement à billes à gorge profonde	2	2	4	4	4	6	50 %
330	Support de palier	-	-	-	-	-	1	2 pièces
400./...	Joint platg (jeu)	4	6	8	8	9	12	150 %
412	Joint torique ¹⁾	4	6	8	8	9	12	150 %
433	Garniture mécanique	1	1	2	2	2	3	25 %
456	Douille de fond	1	1	2	2	2	3	30 %
500.1	Bague	4	4	8	8	8	12	100 %
500.3	Bague	1	1	2	2	2	3	25 %
502.1/.2	Bague d'usure	2	2	2	3	3	4	50 %
523	Chemise d'arbre	2	2	2	3	3	4	50 %
525	Entrtoise ¹⁾	1	1	1	2	2	2	20 %
---	Accouplement éléments de transmission (jeu)	1	1	2	2	3	4	30 %
Pour version avec garniture de presse-étoupe		Quantité des pièces de réserve						
461	Garniture de presse-étoupe (jeu)	4	4	6	6	6	8	180 %
524	Chemise de protection d'arbre	2	2	2	3	3	4	50 %
								pièces supprimées 400.3, 433, 500.3, 523

1) Seulement pour Etanorm-R 125-500/2

2) Pour Etanorm-R 125-500/2 multiplier la quantité par deux

