

SKF

www.motralec.com
service-commercial@motralec.com

Needle roller bearings

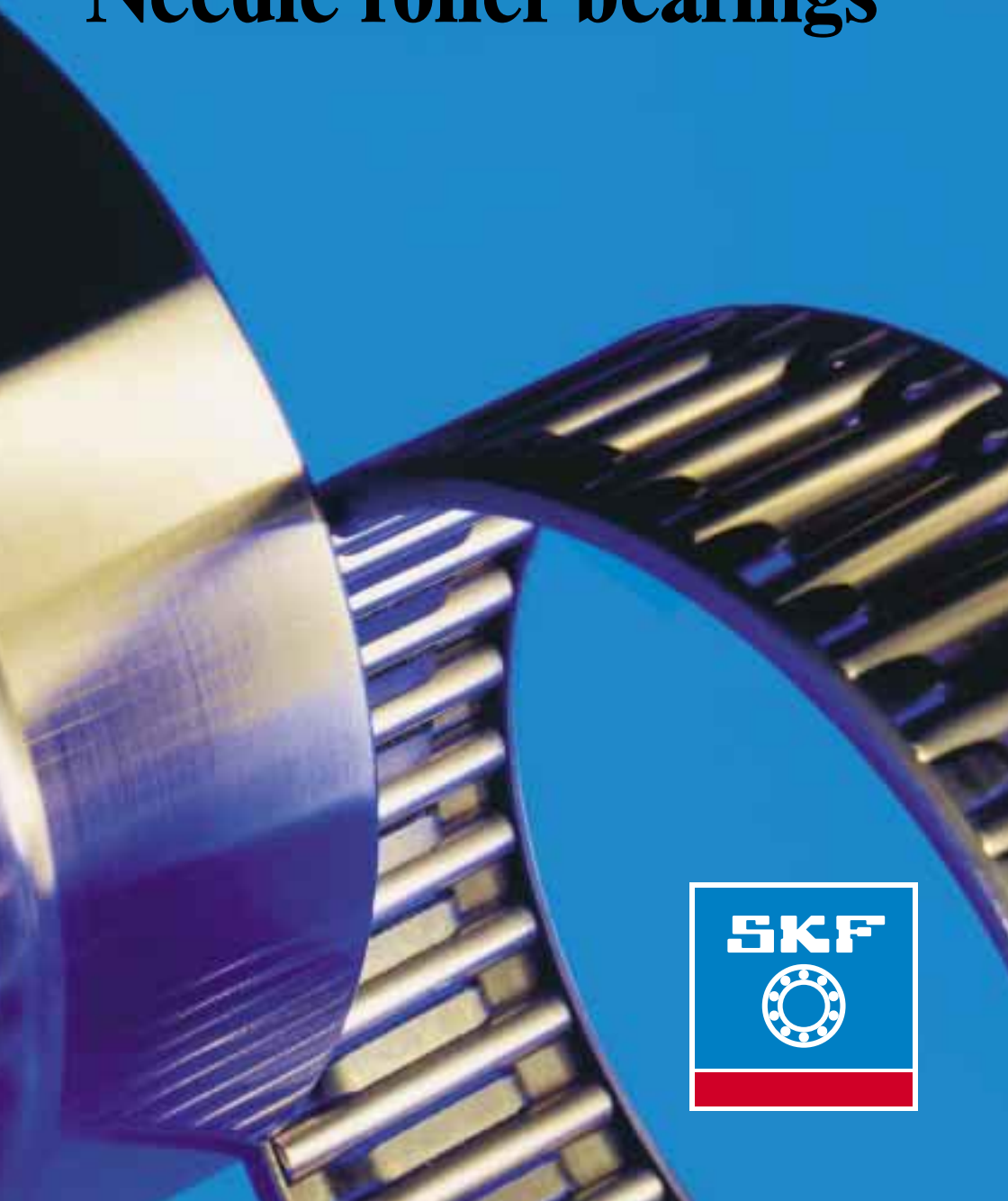

© Copyright SKF 2001

The contents of this catalogue are the copyright of the publisher and may not be reproduced (even extracts) unless permission is granted. Every care has been taken to ensure the accuracy of the information contained in this catalogue but no liability can be accepted for any loss or damage whether direct, indirect or consequential arising out of the use of the information contained here in.

Catalogue **4703/I E**

Printed in Sweden on environmentally friendly paper by Elanders Graphic Systems AB.

General	3	1
Foreword	5	
The SKF Group – a worldwide corporation	6	

Bearing data	9	2
Bearing types	10	
Bearing data – general	14	
Speeds	14	
Tolerances	14	
Internal clearance	21	
Materials	22	
Supplementary designations	24	
Design of associated components	26	

Product data	31	3
Needle roller and cage assemblies	33	
Drawn cup needle roller bearings	49	
Needle roller bearings	67	
Alignment needle roller bearings	107	
Needle roller thrust bearings	117	
Combined needle roller bearings	129	
Support rollers	159	
Cam followers	181	
Components and accessories	203	

Product index	219	4
----------------------------	------------	----------



General

Foreword page 5

The SKF Group – a worldwide corporation page 6

Made by SKF® stands for excellence. It symbolises our consistent endeavour to achieve total quality in everything we do. For those who use our products, “Made by SKF” implies three main benefits.

Reliability – thanks to modern, efficient products, based on our worldwide application know-how, optimised materials, forward-looking designs and the most advanced production techniques.

Cost effectiveness – resulting from the favourable ratio between our product quality plus service facilities, and the purchase price of the product.

Market lead – which you can achieve by taking advantage of our products and services. Increased operating time and reduced down-time, as well as improved output and product quality are the key to a successful partnership.



Foreword

This catalogue gives a representative overview of the range of needle roller bearings and truck runner bearings available from SKF. Compared with the SKF catalogues 4001 and 4703, which it replaces, this catalogue contains considerable alterations and additions and the assortment has been brought up to date.

This catalogue contains all the data relevant to the needle roller and track runner bearings shown. The product tables contain all the data required to select a bearing and for the arrangement of the bearing. A description of the bearing type including design features and other information precedes each product table section. General data regarding speeds, bearing tolerances, internal clearance, materials, supplementary designations and also the design of associated components are included in the catalogue.

The catalogue is designed to enable the information regarding a particular product to be quickly and easily accessed. The contents are divided into four sections which are clearly identified.

The data shown in this catalogue is based on the state of the art in the end of 2000. Thus, compared with the previous catalogue data have been changed or added as a result of product redesign, or more recent computer calculations. The basic dynamic and static load ratings have been calculated according to the latest standards.

The right is reserved make any changes necessitated by the continuous improvement of the product with respect to materials, design and manufacture.

The units used in this catalogue are those specified in ISO 1000:1992, SI units (Système Internationale d'Unités).

The SKF Group – a worldwide corporation

SKF is an international industrial Group operating in some 130 countries and is world leader in bearings.

The company was founded in 1907 following the invention of the self-aligning ball bearing by Sven Wingquist and, after only a few years, SKF began to expand all over the world.

Today, SKF has some 40 000 employees and around 80 manufacturing facilities spread throughout the world. An international sales network includes a large number of sales companies and some 7 000 distributors and retailers. Worldwide availability of SKF products is supported by a comprehensive technical advisory service.

The key to success has been a consistent emphasis on maintaining the highest quality of its products and services. Continuous investment in research and development has also played a vital role, resulting in many examples of epoch-making innovations.

The business of the Group consists of bearings, seals, special steel and a comprehensive range of other high-tech industrial components. The experience gained in these various fields provides SKF with the essential knowledge and expertise required in order to provide the customers with the most advanced engineering products and efficient service.

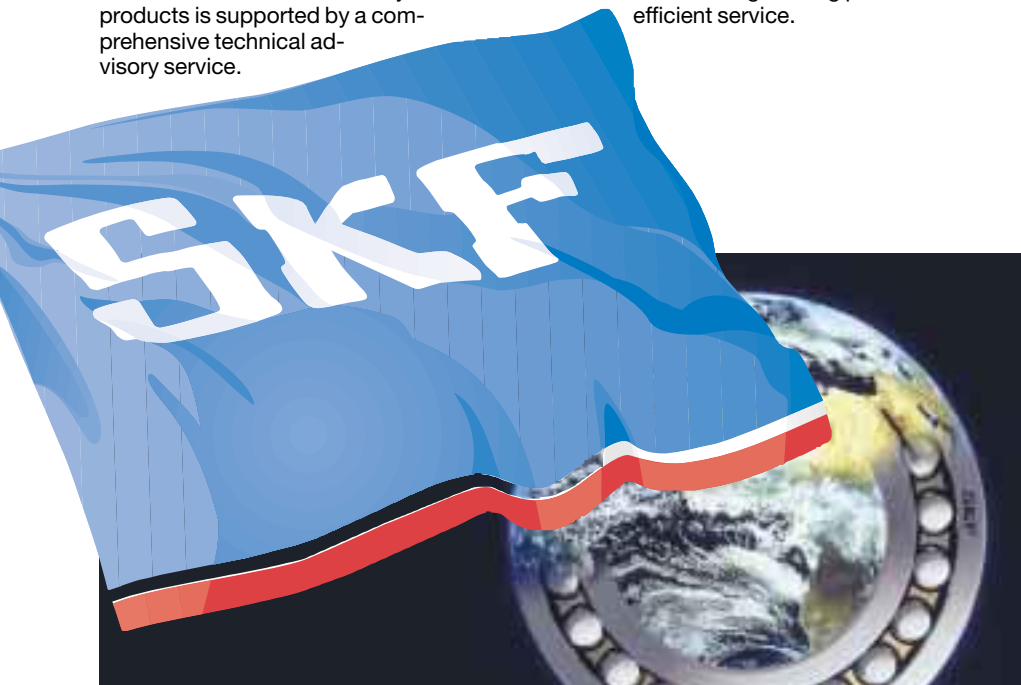

The SKF Group is the first major bearing manufacturer to have been granted approval according to ISO 14001, the international standard for environmental management systems. The certificate is the most comprehensive of its kind and covers more than 60 SKF production units in 17 countries.



The SKF Engineering & Research Centre is situated just outside Utrecht in The Netherlands. In an area of 17 000 square metres (185 000 sq. ft) some 150 scientists, engineers and support staff are engaged in the further improvement of bearing performance. They are developing technologies aimed at achieving better materials, better designs, better lubricants and better seals – together leading to an even better understanding of the operation of a bearing in its application. This is also where the SKF Life Theory was evolved, enabling the design of bearings which are even more compact and offer even longer operational life.



SKF has developed the Channel concept in factories all over the world. This drastically reduces the lead time from raw material to end product as well as work in progress and finished goods in stock. The concept enables faster and smoother information flow, eliminates bottlenecks and bypasses unnecessary steps in production. The Channel team members have the know-ledge and commitment needed to share the responsibility for fulfilling objectives in areas such as quality, delivery time, production flow etc.



SKF manufactures ball bearings, roller bearings and plain bearings. The smallest are just a few millimetres (a fraction of an inch) in diameter, the largest several metres. SKF also manufactures bearing and oil seals which prevent dirt from entering and lubricant from leaking out. SKF's subsidiaries CR and RFT S.p.A. are among the world's largest producers of seals.

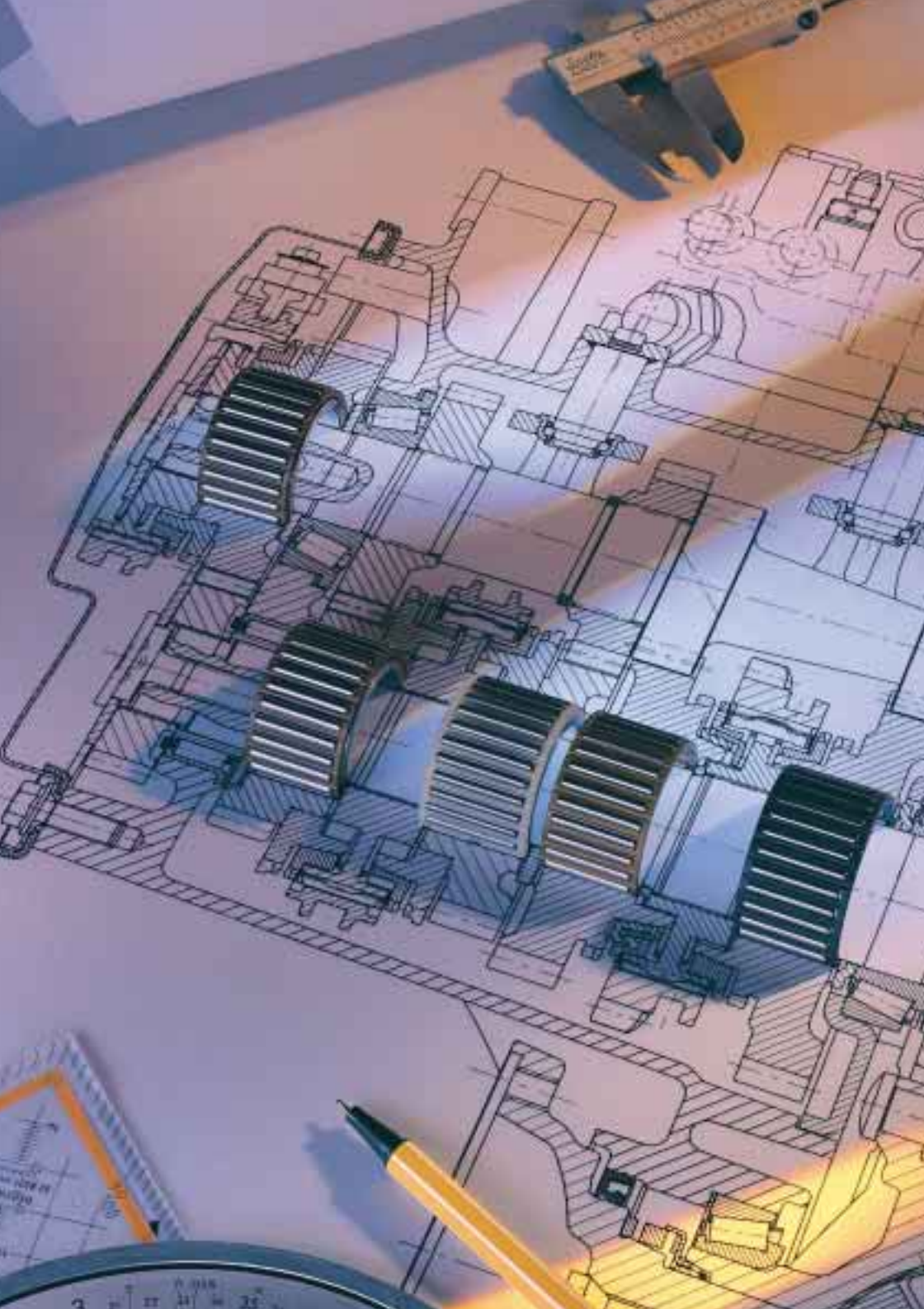

Bearing data

Bearing types	page 10
Bearing data – general	page 14
Speeds	page 14
Tolerances	page 14
Internal clearance	page 21
Materials	page 22
Supplementary designations	page 24
Design of associated components	page 26



Bearing types

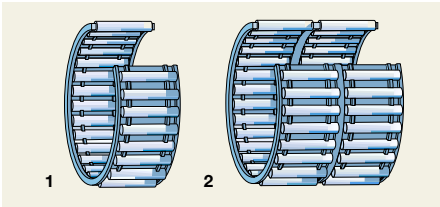

Needle roller and cage assemblies

- single row (1)
- double row (2)
- split

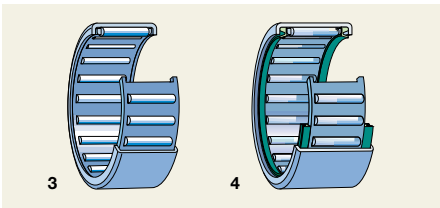

Drawn cup needle roller bearings with open ends

- single row (3)
- double row
- single row, sealed at one side or both sides (4)

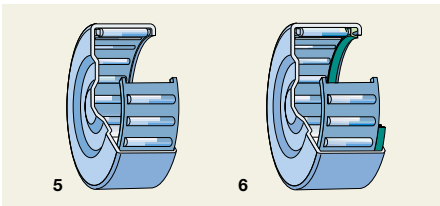

Drawn cup needle roller bearings with closed end

- single row (5)
- double row
- single row, sealed (6)

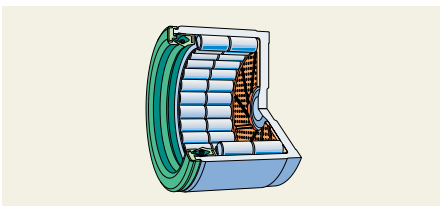

- universal joint bearings (7)

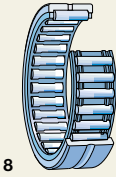

8

Needle roller bearings with flanges

without inner ring
 single row (8)
 double row
 with seals

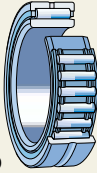

9



10

with inner ring
 single row (9)
 double row
 with seals (10)



11

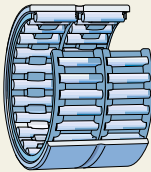

12

Needle roller bearings without flanges

without inner ring
 single row (11)
 double row (12)



13

with inner ring
 single row (13)
 double row



14

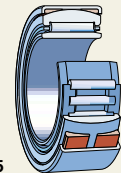

15

Alignment needle roller bearings

without inner ring (14)
 with inner ring (15)

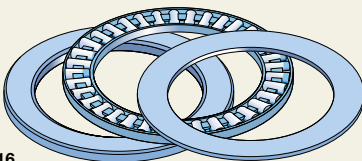

16

Needle roller thrust bearings

single direction
 with (16) and without washers

Bearing types

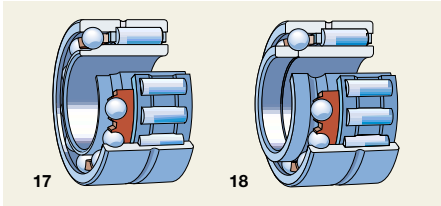

Combined needle roller bearings

Needle roller/angular contact ball bearings

single direction (17)
double direction (18)

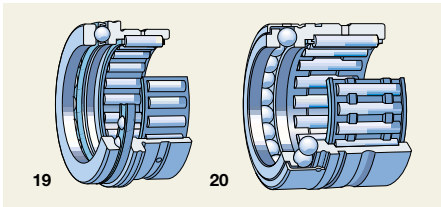

Needle roller/thrust ball bearings

without cover (19)
with cover
with full complement thrust ball bearing (20)

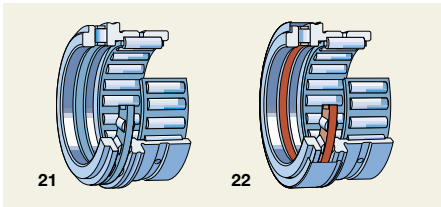

Needle roller/cylindrical roller thrust bearings

single direction
without cover (21)
with cover (22)

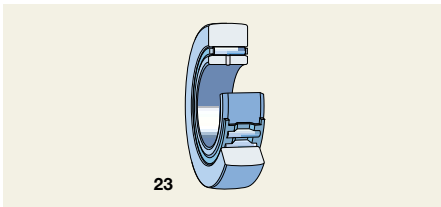

Support rollers without axial guidance

with and without seals
without inner ring
with inner ring (23)

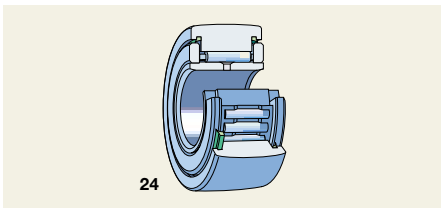

Support rollers with axial guidance by thrust washers

with and without seals
caged (24)
full complement

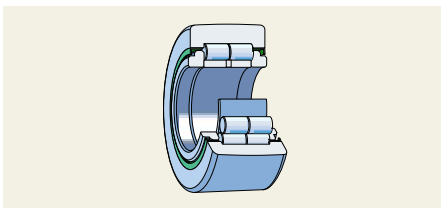

Support rollers with axial guidance by cylindrical rollers

with labyrinth seals (25)

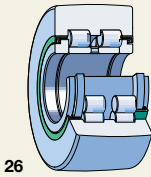

26

**Support rollers with axial guidance
by cylindrical rollers**
with seals (26)

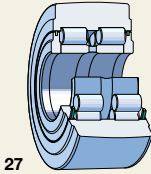

27

with lamellar seals (27)

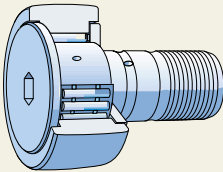

28

**Cam followers with axial guidance
by thrust plate**
with (28) and without cage
with and without seals

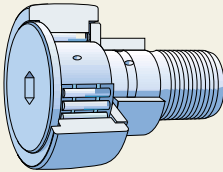

29

with (29) and without eccentric collar

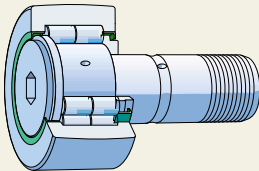

30

**Cam followers with axial guidance
by cylindrical rollers**
with labyrinth seals (30) or seals

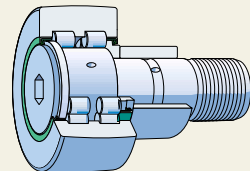

31

with (31) and without eccentric collar

Bearing data – general

Speeds	page 14
Tolerances	page 14
Internal clearance	page 21
Materials	page 22
Supplementary designations	page 24
Design of associated components	page 26

Speeds

The speed ratings given in the bearing tables may be exceeded up to 1,5 times the rating values for radial bearings and 2 times the rating values for thrust bearings provided loads are light, the friction minimised by using a minimum of lubricant and heat removal from the bearing position is good. Conversely, if loads are heavy, lubricant film formation inadequate, friction high because of excess or highly viscous lubricant, or when heat cannot be removed adequately from the bearing position, then it may not be possible to run at speeds as high as the values quoted for the speed ratings.

Reference should also be made to the section “Speeds” in the SKF General Catalogue.

Tolerances

Unless otherwise stated, the needle roller bearings shown in this catalogue are produced to the tolerances for dimensional, form and running accuracy specified in ISO 492:1994 for radial bearings and ISO 199:1997 for thrust bearings.

Tables 2 to 4 on **pages 17 to 19** give the tolerances for radial bearings to tolerance classes Normal, P6 and P5, and **Table 5** on **page 20** gives the tolerances for thrust bearings to tolerance class Normal. The symbols used in the tables are explained opposite.

The tolerance classes in which bearings are available (either as standard, or additionally) will be found in the text preceding the product table sections. Bearings with higher accuracy than to tolerance class Normal are identified by the suffix for the tolerance class in the bearing designation (→ “Supplementary designations”, **page 24**). The suffix is preceded by an oblique stroke.

Tolerance symbols

d	nominal bore diameter
d_{mp}	mean bore diameter; arithmetical mean of the largest and smallest single bore diameters in one plane
Δ_{dmp}	deviation of the mean bore diameter from the nominal ($\Delta_{dmp} = d_{mp} - d$)
V_{dp}	bore diameter variation; difference between the largest and smallest single bore diameters in one plane
V_{dmp}	mean bore diameter variation; difference between the largest and smallest single bore diameters in one plane
D	nominal outside diameter
D_{mp}	mean outside diameter; arithmetical mean of the largest and smallest single outside diameters in one plane
Δ_{Dmp}	deviation of the mean outside diameter from the nominal ($\Delta_{Dmp} = D_{mp} - D$)
V_{Dp}	outside diameter variation; difference between the largest and smallest single outside diameters in one plane
V_{Dmp}	mean outside diameter variation; difference between the largest and smallest mean bore diameters of one ring or washer
B_s, C_s	single width of inner ring and outer ring, respectively
Δ_{Bs}, Δ_{Cs}	deviation of single inner ring width or single outer ring width from the nominal ($\Delta_{Bs} = B_s - B$; $\Delta_{Cs} = C_s - C$)
V_{Bs}, V_{Cs}	ring width variation; difference between the largest and smallest single widths of inner ring and of outer ring, respectively
T_s	single height (H) of single direction thrust bearing
Δ_{Ts}	deviation of single height of thrust bearing from the nominal ($\Delta_{Ts} = T_s - T$)
K_{ia}, K_{ea}	radial runout of assembled bearing inner ring and assembled bearing outer ring, respectively
S_d	side face runout with reference to bore (of inner ring)

S_D	outside inclination variation; variation in inclination of outside cylindrical surface to outer ring side face
S_i, S_e	thickness variation, measured from middle of raceway to back (seating) face of shaft washer and of housing washer, respectively (axial runout)

Bearing data – general

Limits for chamfer dimensions

To prevent the improper dimensioning of associated components for needle roller bearings and to facilitate the calculation of retaining ring location arrangements, the maximum chamfer limits for the relevant minimum chamfer dimensions given in the product tables will be found in **Table 1**. These limits conform to ISO 582:1995. The symbols used in the tables are explained below.

- d nominal bore diameter
- r_1, r_3 chamfer dimensions in radial direction
- r_2, r_4 chamfer dimensions in axial direction
- $r_{s \min}$ general symbol for minimum limit of $r_1, r_2, r_3,$ and r_4 (single chamfer dimension)

Table 1

Chamfer dimension limits

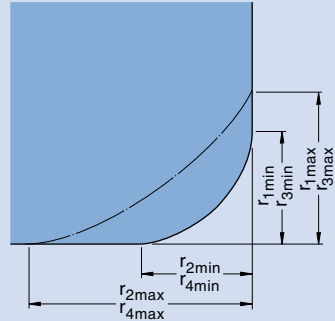

Minimum value $r_{s \min}$	Nominal bearing bore diameter d		Maximum values		
	over	incl.	Radial bearings $r_{1,3}$ max	Radial bearings $r_{2,4}$ max	Thrust bearings $r_{1,2,3,4}$ max
mm	mm		mm		
0,1	–	–	0,2	0,4	0,2
0,15	–	–	0,3	0,6	0,3
0,2	–	–	0,5	0,8	0,5
0,3	–	40	0,6	1	0,8
	40	–	0,8	1	0,8
0,6	–	40	1	2	1,5
	40	–	1,3	2	1,5
1	–	50	1,5	3	2,2
	50	–	1,9	3	2,2
1,1	–	120	2	3,5	2,7
	120	–	2,5	4	2,7
1,5	–	120	2,3	4	3,5
	120	–	3	5	3,5
2	–	80	3	4,5	4
	80	220	3,5	5	4
	220	–	3,8	6	4
2,1	–	280	4	6,5	4,5
	280	–	4,5	7	4,5

Table 2

Normal tolerances for radial bearings

Inner ring

d		Δ_{dmp}		V_{dp}	V_{dmp}	Δ_{Bs}		V_{Bs}	K_{ia}
over	incl.	high	low	max	max	high	low	max	max
mm		μm		μm	μm	μm		μm	μm
2,5	10	0	-8	10	6	0	-120	15	10
10	18	0	-8	10	6	0	-120	20	10
18	30	0	-10	13	8	0	-120	20	13
30	50	0	-12	15	9	0	-120	20	15
50	80	0	-15	19	11	0	-150	25	20
80	120	0	-20	25	15	0	-200	25	25
120	180	0	-25	31	19	0	-250	30	30
180	250	0	-30	38	23	0	-300	30	40
250	315	0	-35	44	26	0	-350	35	50
315	400	0	-40	50	30	0	-400	40	60
400	500	0	-45	56	34	0	-450	50	65

Outer ring

D		Δ_{Dmp}		V_{Dp}	V_{Dmp}	Δ_{Cs}, V_{Cs}	K_{ea}
over	incl.	high	low	max	max		max
mm		μm		μm	μm		μm
6	18	0	-8	10	6	Values are identical to those for inner ring of same bearing (Δ_{Bs}, V_{Bs})	15
18	30	0	-9	12	7		15
30	50	0	-11	14	8		20
50	80	0	-13	16	10		25
80	120	0	-15	19	11		35
120	150	0	-18	23	14		40
150	180	0	-25	31	19	45	
180	250	0	-30	38	23	50	
250	315	0	-35	44	26	60	
315	400	0	-40	50	30	70	
400	500	0	-45	56	34	80	
500	630	0	-50	63	38	100	

Table 3

Class P6 tolerances for radial bearings									
Inner ring									
d		Δ_{dmp}		V_{dp}	V_{dmp}	Δ_{Bs}		V_{Bs}	K_{ia}
over	incl.	high	low	max	max	high	low	max	max
mm		μm		μm	μm	μm		μm	μm
2,5	10	0	-7	9	5	0	-120	15	6
10	18	0	-7	9	5	0	-120	20	7
18	30	0	-8	10	6	0	-120	20	8
30	50	0	-10	13	8	0	-120	20	10
50	80	0	-12	15	9	0	-150	25	10
80	120	0	-15	19	11	0	-200	25	13
120	180	0	-18	23	14	0	-250	30	18
180	250	0	-22	28	17	0	-300	30	20
250	315	0	-25	31	19	0	-350	35	25
315	400	0	-30	38	23	0	-400	40	30
400	500	0	-35	44	26	0	-450	45	35

Outer ring								
D		Δ_{Dmp}		V_{Dp}	V_{Dmp}	Δ_{Cs}, V_{Cs}		K_{ea}
over	incl.	high	low	max	max			max
mm		μm		μm	μm			μm
6	18	0	-7	9	5	Values are identical to those for inner ring of same bearing (Δ_{Bs}, V_{Bs})		8
18	30	0	-8	10	6			9
30	50	0	-9	11	7			10
50	80	0	-11	14	8			13
80	120	0	-13	16	10			18
120	150	0	-15	19	11			20
150	180	0	-18	23	14			23
180	250	0	-20	25	15			25
250	315	0	-25	31	19			30
315	400	0	-28	35	21			35
400	500	0	-33	41	25			40
500	630	0	-38	48	29			50

Table 4

Class P5 tolerances for radial bearings

Inner ring

d		Δ_{dmp}		V_{dp}	V_{dmp}	Δ_{Bs}		V_{Bs}	K_{ia}	S_d
over	incl.	high	low	max	max	high	low	max	max	max
mm		μm		μm	μm	μm		μm	μm	μm
2,5	10	0	-5	5	3	0	-40	5	4	7
10	18	0	-5	5	3	0	-80	5	4	7
18	30	0	-6	6	3	0	-120	5	4	8
30	50	0	-8	8	4	0	-120	5	5	8
50	80	0	-9	9	5	0	-150	6	5	8
80	120	0	-10	10	5	0	-200	7	6	9
120	180	0	-13	13	7	0	-250	8	8	10
180	250	0	-15	15	8	0	-300	10	10	11
250	315	0	-18	18	9	0	-350	13	13	13
315	400	0	-23	23	12	0	-400	15	15	15
400	500	0	-27	27	14	0	-450	18	17	18

Outer ring

D		Δ_{Dmp}		V_{Dp}	V_{Dmp}	Δ_{Cs}	V_{Cs}	K_{ea}	S_D
over	incl.	high	low	max	max		max	max	max
mm		μm		μm	μm		μm	μm	μm
6	18	0	-5	5	3	Values are identical to those for inner ring of same bearing (Δ_{Bs})	5	5	8
18	30	0	-6	6	3		5	6	8
30	50	0	-7	7	4		5	7	8
50	80	0	-9	9	5		6	8	8
80	120	0	-10	10	5		8	10	9
120	150	0	-11	11	6		8	11	10
150	180	0	-13	13	7	8	13	10	
180	250	0	-15	15	8	10	15	11	
250	315	0	-18	18	9	11	18	13	
315	400	0	-20	20	10	13	20	13	
400	500	0	-23	23	12	15	23	15	
500	630	0	-28	28	14	18	25	18	

Normal tolerances for thrust bearings

Shaft washer

d		Δ_{dmp}		V_{dp}	S_i	Δ_{Ts} ¹⁾	
over	incl.	high	low	max	max	high	low
mm		μm		μm	μm	μm	
–	18	0	–8	6	10	+20	–250
18	30	0	–10	8	10	+20	–250
30	50	0	–12	9	10	+20	–250
50	80	0	–15	11	10	+20	–300
80	120	0	–20	15	15	+25	–300
120	180	0	–25	19	15	+25	–400

¹⁾ Not valid where thrust washers of series AS are used

Housing washer

D		Δ_{Dmp}		V_{Dp}	S_e
over	incl.	high	low	max	
mm		μm		μm	
18	30	0	–13	10	Values are identical to those for shaft washer of same bearing (S _i)
30	50	0	–16	12	
50	80	0	–19	14	
80	120	0	–22	17	
120	180	0	–25	19	
180	250	0	–30	23	

Internal clearance

Bearing internal clearance is defined as the total distance through which one bearing ring can be moved relative to the other in the radial direction (radial internal clearance) or in the axial direction (axial internal clearance).

It is necessary to distinguish between the internal clearance of a bearing before mounting and the internal clearance in a mounted bearing which has reached its operating temperature (operational clearance). The initial internal clearance (before mounting) is greater than the operational clearance because different degrees of interference in the fits and differences in thermal expansion of the bearing rings and the associated components cause the rings to be expanded or compressed.

The bearing internal clearance referred to as Normal has been selected so that a suitable operational clearance will be obtained when bearings are mounted with the fits

usually recommended and operating conditions are normal. Where operating and mounting conditions differ from the normal, e.g. where interference fits are used for both bearing rings, unusual temperatures prevail etc., bearings with greater or smaller internal clearance than Normal are required. In such cases it is recommended that the residual clearance in the bearing after it has been mounted be checked.

SKF needle roller bearings with inner ring are supplied as standard with Normal radial internal clearance, unless otherwise stated. Bearings having an internal clearance other than Normal are identified by the suffixes C2, C3 and C4.

The limits for radial internal clearance correspond to ISO 5753:1991 and are given in **Table 6**.

Table 6

Radial internal clearance for needle roller bearings

Bore diameter d		Radial internal clearance							
over	incl.	C2		Normal		C3		C4	
		min	max	min	max	min	max	min	max
mm		µm							
-	30	0	25	20	45	35	60	50	75
30	40	5	30	25	50	45	70	60	85
40	50	5	35	30	60	50	80	70	100
50	65	10	40	40	70	60	90	80	110
65	80	10	45	40	75	65	100	90	125
80	100	15	50	50	85	75	110	105	140
100	120	15	55	50	90	85	125	125	165
120	140	15	60	60	105	100	145	145	190
140	160	20	70	70	120	115	165	165	215
160	180	25	75	75	125	120	170	170	220
180	200	35	90	90	145	140	195	195	250
200	225	45	105	105	165	160	220	220	280
225	250	45	110	110	175	170	235	235	300
250	280	55	125	125	195	190	260	260	330
280	315	55	130	130	205	200	275	275	350
315	355	65	145	145	225	225	305	305	385
355	400	100	190	190	280	280	370	370	460

Materials

Bearing rings and rolling elements

The rings and rolling elements of SKF needle roller bearings are made of a through-hardening carbon chromium steel to DIN 17 230:1980 containing approximately 1 % carbon and 1,5 % chromium. The thin-walled deep drawn outer rings of drawn cup and alignment needle roller bearings are exceptions to the above and are made of mild steel to DIN 17 230:1980.

All components are hardened and can generally be used at operating temperatures up to +125 °C. If the operating temperatures are higher, the bearings must be subjected to a special heat treatment (stabilisation) so that inadmissible changes in dimensions do not occur as a result of structural changes in the steel. However, the bearings should not be stabilised for a higher temperature than the expected operating temperature.

As the load carrying capacity of bearings decreases with increasing temperature, the basic dynamic load rating C should be multiplied by an appropriate reduction factor, see following.

Bearing temperature (°C)	150	200	250	300
Reduction factor	1,00	0,90	0,75	0,60

Cages

Various cage types and designs are used for the different types and sizes of SKF needle roller bearing types; the cages differ as to form, material, manufacturing methods, cost of production and operational limits. The standard cage for a particular bearing is not identified in the bearing designation unless it is of polyamide.

With reference to the viability of production, the costs and the different application areas of the bearings, the standard cage for the larger bearings may be different from that for the smaller bearings in one and the same series.

In the introductory text to each table section information is provided regarding the standard cages with which the bearings are fitted and also the possible alternatives.

Polyamide cages

Small and medium-sized bearings are fitted with moulded cages of heat-stabilised, glass fibre reinforced polyamide 6,6 as standard. This material is characterised by a favourable combination of strength and elasticity. The good sliding properties of the plastic on lubricated steel surfaces and the smoothness of the cage surfaces in contact with the rolling elements mean that little friction is produced by the cage so that heat generation and wear in the bearing are at a minimum. The low density of the material means that the inertia of the cage is small. The injection moulding process used to produce the cages allows functionally suitable designs to be realised. The excellent running properties of polyamide cages under lubricant starvation conditions permit continued operation of the bearing for a time without any risk of seizure and secondary damage.

When using bearings with polyamide cages the permissible operating temperatures for the material and its resistance to the lubricant used must be observed. At operating temperatures up to the values given in **Table 7** for the various oils and greases which are used as bearing lubricants, cage properties are unaffected. If the permissible temperature is exceeded, the cage material will age, this process being accelerated the longer the cage is exposed to the excessive

temperature. Brief periods at up to 20 °C above the recommended maximum temperatures can be tolerated provided they are interspersed with longer periods at operating temperatures below the recommended values, and provided the maximum operating temperature for the lubricant is not exceeded. When operating temperatures are constantly above 120 °C, bearings fitted with metallic cages must be used. Polyamide cages are also unsuitable for operating temperatures below –40 °C as they lose their elasticity.

The organic solvents normally used to clean rolling bearings such as white spirit or trichlorethane do not affect cage properties, nor do dilute alkaline cleaners (e.g. soda) if they are at room temperature and the period during which they are in contact is short. The chlorofluorocarbons or ammonia used in refrigeration do not attack polyamide. In vacuum, polyamide cages become brittle because they become dehydrated.

Steel cages

The majority of SKF needle roller bearings are fitted with pressed cages of steel or sheet steel. These cages have relatively high strength and weigh little. They take up little space in the bearing and therefore allow adequate lubricant supply to the roller/race-way contacts.

The sheet steel cages are produced from deep drawing strip or tube. The joints are welded. To reduce friction and wear they may be hardened and surface treated.

The steel cages are produced from mild steel tube and have profiled surfaces.

Steel cages can be used at operating temperatures up to 300 °C. They are not affected by the mineral or synthetic oil-based lubricants normally used for rolling bearings, nor by the organic solvents used to clean bearings. There is a risk of corrosion where water is present.

Table 7

Permissible operating temperatures for cages of glass fibre reinforced polyamide 6,6 with various bearing lubricants

Lubricant	Permissible operating temperature ¹⁾
–	°C
Mineral oils	
Oils without EP additives e.g. machine oils, hydraulic oils	120
EP oils e.g. industrial and automotive gearbox oils	110
EP oils e.g. rear axle and differential gear oils (automotive), hypoid gear oils	100
Synthetic oils	
Polyglycols, poly- α -olefins	120
Diesters, silicones	110
Greases	
Lithium base ²⁾ , polyurea, bentonite, calcium complex	120

¹⁾ Measured on the outside surface of the outer ring

²⁾ For sodium and calcium base greases and other bearing greases with a maximum operating temperature below 120 °C, the maximum temperature for the polyamide cage is the same as the maximum operating temperature for the grease; otherwise the permissible maximum operating temperature is 120 °C

Supplementary designations

The complete designation for a needle roller bearing product consists of the basic designation, which identifies bearing type and size, as well as any supplementary designations in the form of suffixes. These suffixes identify design features which differ from the original standard design. The features are divided into groups and when more than one feature is to be identified, the appropriate suffixes appear in a given order. Those suffixes which are commonly used to identify certain features of SKF needle roller bearings are explained in the following.

AS	Bearing with lubrication hole(s) in the outer ring; a figure following AS gives the number of holes	H	Reduced tolerance for the inside diameter of the cage and roller assembly. The figures following the letter H indicate the tolerance limits in μm , e.g. H+20+27
ASR	Bearing with annular groove and lubrication hole(s) in the outer ring; a figure following ASR gives the number of holes	HT..	Special grease for high temperatures (up to +130 °C); the two figures following HT identify the actual grease
BF	Needle roller with flat ends	IS	Bearing with lubrication hole(s) in the inner ring; a figure following IS indicates the number of holes
BIR	Profiled inner ring raceway	ISR	Bearing with annular groove and lubrication hole(s) in the inner ring; a figure following ISR indicates the number of holes
C2	Radial internal clearance smaller than Normal	JPC	Profiled, roller guided pressed sheet steel cage. Different designs are identified by a figure, e.g. J1PC
C3	Radial internal clearance greater than Normal	JPCS	Welded JPC cage, example: K 100×108×30 ZWJPCS
C4	Radial internal clearance greater than C3	M./M.	Diameter tolerance of needle rollers (e.g. M2/M4 – diameter tolerance –2 to –4 μm)
D	Changed internal design of bearing of same type and size as original. Generally dropped after a certain changeover period, but may be retained where variants of the same type and size of bearing have to be distinguished	MT..	Special grease for moderate temperatures (up to +110 °C); the two figures following MT identify the actual grease
DS	Split needle roller and cage assembly	N/M.	Diameter tolerance of needle rollers (e.g. N/M4 – diameter tolerance 0 to –4 μm)
DSTN	DS + TN	PP	Seals at both sides of a support roller or cam follower
EGS	Inner ring with non-directionally ground raceway	P4	Dimensional and running accuracy to ISO tolerance class 4 specifications (better than P5)
FMA	M-profile machined steel cage, outer ring centred	P5	Dimensional and running accuracy to ISO tolerance class 5 specifications (better than P6)
FPA	Window-type steel cage (from single blank, with punched or reamed pockets), outer ring centred	P6	Dimensional and running accuracy to ISO tolerance class 6 specifications (better than Normal)
GP	Noise tested bearing	P62	P6 + C2
		P63	P6 + C3
		RS	Rubbing seal at one side of bearing
		.2RS	Rubbing seals at both sides of bearing
		S	Matched bearings for an equal distribution of radial load. A figure preceding the S indicates the number of bearings

SK	Cam follower with internal hexagon at head side of stud
SM..	Bearing filled with a special grease; the two figures following SM identify the actual grease
/SORT	Gauge of the needle rollers of an assembly. The figures following indicate the gauge limits in μm , e.g. KZK 18x24x13/SORT-1-3
S0	Bearing, the rings or washers of which have been stabilised for operating temperatures up to +150 °C
S1	Bearing, the rings or washers of which have been stabilised for operating temperatures up to +200 °C
S2	Bearing, the rings or washers of which have been stabilised for operating temperatures up to +250 °C
TN	Injection moulded glass fibre reinforced polyamide 6,6 cage
V	Full complement of rollers (no cage)
VGS	Preground raceway on inner ring
X	Support roller and cam follower with cylindrical runner surface on the outer ring instead of standard crowned runner surface
Z	Bearing with cover
ZTN	Z + TN
ZW	Double row cage
ZWTN	ZW + TN
2ZL	Support roller with two lamellar seals arranged between grooves in the outer ring shoulders and in the shoulders of the non-integral flange rings

Design of associated components

Dimensional, form and running accuracy of bearing seatings and abutments

The accuracy of cylindrical bearing seatings on shafts and in housing bores, of seatings for thrust bearing washers and of the support surfaces (abutments for bearings provided by shaft and housing shoulders etc.) should correspond to the accuracy of the bearings used. In the following, guideline values for the dimensional, form and running accuracy are given. These should be followed when machining the seatings and abutments.

Dimensional tolerances

For bearings made to Normal tolerances, the dimensional accuracy of cylindrical seatings on the shaft should be at least to grade 6 and in the housing at least to grade 7. For bearings with higher accuracy, correspondingly better grades should be used. The basic tolerances to ISO 286-1:1988 will be found in **Table 8**.

Tolerances for cylindrical form

The cylindricity tolerances as defined in ISO 1101-1985 should be 1 to 2 IT grades better than the prescribed dimensional tolerance, depending on requirements. For example, if a bearing shaft seating has been machined to tolerance f6, then the accuracy of form should be to IT5 or IT4. **Table 9** gives guideline values for the cylindrical form tolerance and the total runout tolerance for the different bearing tolerance classes.

Tolerances for perpendicularity

Abutments for bearing rings should have a rectangularity tolerance as defined in ISO 1101-1983 which is better by at least one IT grade than the diameter tolerance of the associated cylindrical seating. For thrust bearing washer seatings, the perpendicularity tolerance should not exceed the values of IT5. Guideline values for the rectangularity tolerance and for the total axial runout will be found in the **Table 9**.

Table 8

Limits for ISO tolerance grades							
Nominal dimension over	incl.	Tolerance grades					
		IT2	IT3	IT4	IT5	IT6	IT7
mm		µm					
1	3	1,2	2	3	4	6	10
3	6	1,5	2,5	4	5	8	12
6	10	1,5	2,5	4	6	9	15
10	18	2	3	5	8	11	18
18	30	2,5	4	6	9	13	21
30	50	2,5	4	7	11	16	25
50	80	3	5	8	13	19	30
80	120	4	6	10	15	22	35
120	180	5	8	12	18	25	40
180	250	7	10	14	20	29	46
250	315	8	12	16	23	32	52
315	400	9	13	18	25	36	57
400	500	10	15	20	27	40	63

Accuracy of form and position for bearing seatings on shafts and in housings

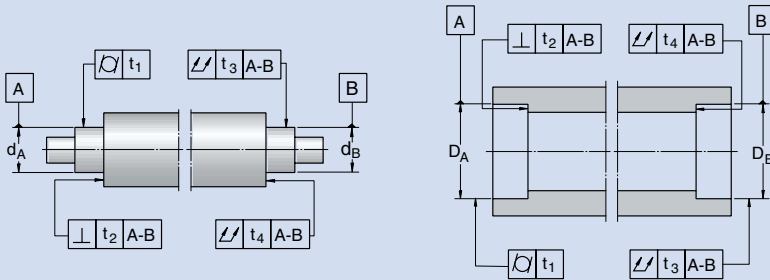

Surface Characteristic	Symbol for characteristic	tolerance zone	Permissible deviation Bearings of tolerance class ¹⁾		
			Normal	P6	P5

Cylindrical seating

Cylindricity	○	t_1	$\frac{IT5}{2}$	$\frac{IT4}{2}$	$\frac{IT3}{2}$
Total radial runout	∕∕	t_3	$\frac{IT5}{2}$	$\frac{IT4}{2}$	$\frac{IT3}{2}$

Flat abutment

Rectangularity	⊥	t_2	IT5	IT4	IT3
Total axial runout	∕∕	t_4	IT5	IT4	IT3

¹⁾ The basic tolerance grades stated are valid for normal demands on the bearing arrangement. For special demands in respect of running accuracy or even support the bearing seating should be machined to the basic tolerance grades recommended for the next higher bearing tolerance class



Bearing data – general

Surface roughness of bearing seatings

The roughness of bearing seating surfaces does not have the same degree of influence on bearing performance as the dimensional, form and running accuracies. However, a desired interference fit is much more accurately obtained the smoother the mating surfaces. For less critical bearing arrangements relatively large surface roughnesses are permitted. For bearing arrangements where demands in respect of accuracy are high, guideline values for the mean surface roughness R_a are given in **Table 10** for the different dimensional accuracies of the bearing seatings. These recommendations apply to ground seatings, which are normally assumed for shaft seatings.

Raceways on shafts and in housings

Raceways machined in associated components for

- needle roller and cage assemblies,
- drawn cup needle roller bearings,
- needle roller bearings having only one ring,
- combined needle roller bearings without inner ring,
- needle roller and cage thrust assemblies and
- support rollers without inner ring

must have a hardness of between 58 and 64 HRC if the load carrying capacity of the bearing or assembly is to be fully exploited.

Influence of raceway hardness

Raceways having a hardness under 58 HRC reduce the load carrying capacity of the bearing arrangement. This is taken into account by multiplying the basic dynamic load rating by a reduction factor f_c from **Table 11**.

Raceway surface finish and accuracy

The surface roughness should be $R_a \leq 0,2 \mu\text{m}$ or $R_z \leq 1 \mu\text{m}$. For less demanding applications, lower hardness and rougher surfaces may be used.

For radial bearing arrangements,

- the out-of-round should not exceed 25 %, and
- the deviation from cylindrical form should not exceed 50 %,

of the actual diameter tolerance of the raceway.

The permissible axial runouts of raceways for the needle roller and cage thrust assemblies are the same as for the shaft and housing washers of thrust bearings (**→ Table 5, page 20**).

Raceway materials

Suitable materials for the seatings include

- through-hardening steels to DIN 17 230:1980, e.g. steel 100 Cr 6,
- case-hardening steels to DIN 17 210:1986 and 17 230:1980, e.g. 15 CrNi 6 or 16 MnCr 5, as well as
- steels for flame or induction hardening to DIN 17 212:1972 or DIN 17 230:1980, which can be partially hardened.

Table 10

Guideline values for surface roughness of bearing seatings				
Diameter of seating d (D)		Recommended R_a value for ground seatings		
over	incl.	Diameter tolerance to		
		IT7	IT6	IT5
mm		μm		
–	80	1,6 (N7)	0,8 (N6)	0,4 (N5)
80	500	1,6 (N7)	1,6 (N7)	0,8 (N6)

The case depth which is recommended for raceways machined in associated components depends on various factors including the dynamic and static load ratios (P/C and P_0/C_0 respectively) as well as the core hardness, and it is difficult to generalise. For example, under conditions of purely static load up to the magnitude of the basic static load rating and with a core hardness of 350 HV, the recommended case depth is of the order of 0,1 times the rolling element diameter. Smaller case depths are permitted for dynamic loads. Please contact SKF for advice.

Table 11

Reduction factor f_c	
Raceway hardness (HRC)	Reduction factor f_c for dynamic load conditions
55	0,7
50	0,5
45	0,4
40	0,3
35	0,25
30	0,2



Product data

Needle roller and cage assemblies	page 33
Drawn cup needle roller bearings	page 49
Needle roller bearings	page 67
Alignment needle roller bearings	page 107
Needle roller thrust bearings	page 117
Combined needle roller bearings	page 129
Support rollers	page 159
Cam followers	page 181
Components and accessories	page 203



Needle roller and cage assemblies

Product tables page 40

SKF needle roller and cage assemblies are ready-to-mount, self-contained, bearing arrangement components. They enable bearing arrangements to be produced which have high load carrying capacity and stiffness and require a minimum of radial space if the shaft and housing bore can serve as raceways and have the same hardness and surface finish as bearing rings. If the raceways are made with increased accuracy, bearing arrangements with high running accuracy can be achieved.

SKF needle roller and cage assemblies are available in single row (→ **fig 1**) and double row (→ **fig 2**) designs. They are characterised by

- simple and rugged design,
- accurate guidance of the rollers in the cage pockets, and
- good running properties.

The needle rollers are slightly relieved towards their ends. The modified line contact thus achieved between rollers and raceways means that damaging edge stresses are avoided.

Fig 1

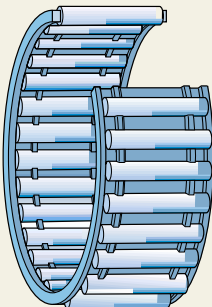
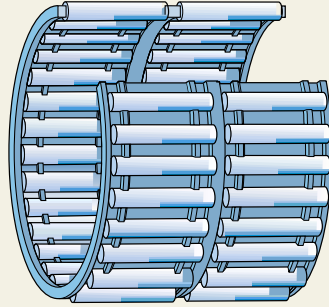

Fig 2



3

Fig 3

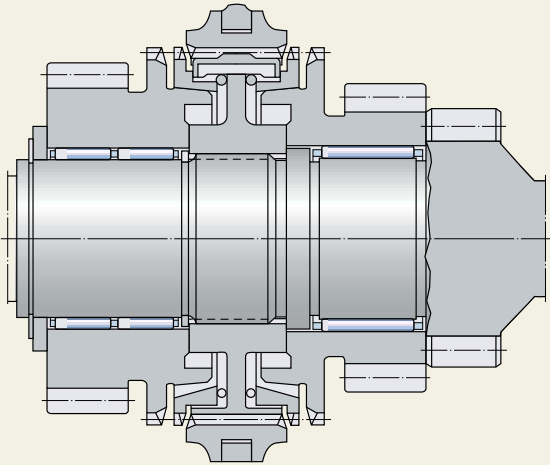

Fig 4

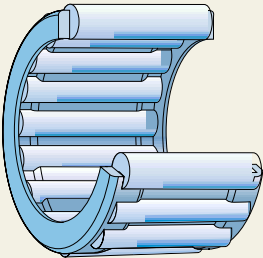
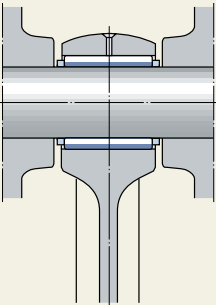
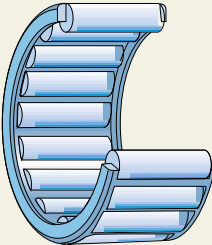
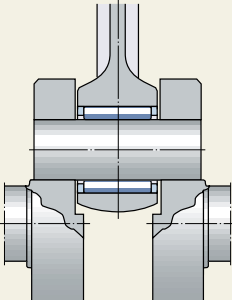

Fig 5



Other needle roller and cage assemblies

The needle roller and cage assemblies listed in the product tables form only a part of the comprehensive range available from SKF. This not only includes other sizes but also assemblies with cages which differ from the standard cage design, for example split needle roller and cage assemblies, which can be used where raceways are recessed in the shaft (→ fig 3).

For the connecting rod bearing arrangements of combustion engines and compressors, SKF has special needle roller and cage assemblies for gudgeon pin bearing arrangements (→ fig 4) and crankpin bearing arrangements (→ fig 5). The assemblies for these applications, where high accelerations occur, have given excellent service in spite of the difficult operating conditions, including high temperatures or unfavourable load, movement or lubrication conditions.

To special order, SKF also produces special sizes of needle roller and cage assemblies, when the quantities required are economical.

Details of these other needle roller and cage assemblies will be sent on request.

Dimensions

The dimensions of needle roller and cage assemblies with inside diameter up to and including 100 mm, where standardised, conform to ISO 3030:1996.

Tolerances

SKF needle roller and cage assemblies each contain rollers of one gauge of grade G2 (ISO 3096:1996 Grade 2). The tolerance of each gauge is 2 µm maximum. The relevant gauge is indicated by a coloured slip enclosed in the package (→ Table 1). The deviations from the nominal dimensions of the needle rollers are also printed on the package.

Supplies of needle roller and cage assemblies may comprise assemblies of any gauge (red, blue, white or grey) unless specific requirements are stated when ordering. Assemblies with rollers of special gauge (green and yellow) are only available to special order.

The tolerances for the width U are -0,20/-0,80 mm for all assemblies.

Paired mounting

If needle roller and cage assemblies are to be mounted immediately adjacent to each other, they must incorporate rollers of the same gauge, so that both assemblies carry the load equally.

Table 1

Needle roller gauges		
Gauge type	Colour	Gauge in µm
Standard gauges	red	0/-2 -1/-3
	blue	-2/-4 -3/-5
	white (grey)	-4/-6 -5/-7
Special gauges (to order)	green	-6/-8 -7/-9
	yellow	-8/-10 -9/-11

Needle roller and cage assemblies

Internal clearance

The radial internal clearance of bearing arrangements incorporating needle roller and cage assemblies is determined by the gauge of the needle rollers in combination with the shaft and housing raceway tolerances and the operating temperature. Suitable raceway tolerances which have been well proven in practice are given in **Table 2**.

If applied when using assemblies incorporating rollers of standard gauge (→ **Table 1**), the radial internal clearance will lie in the range of C2 and Normal (→ **Table 6** on **page 21**).

If a specific radial internal clearance is required in a given bearing arrangement, it is recommended that the various components of the arrangement are matched, e.g. following a matching plan as shown in **Table 3**. It should be observed that the mean value of the needle roller gauge should be used to calculate the internal clearance, i.e. $-6 \mu\text{m}$ for the gauge $-5/-7 \mu\text{m}$.

The example shown in **Table 3** will produce a small operational clearance, i.e. less than normal.

Misalignment

The modified line contact between the raceways and the needle rollers not only prevents damaging edge stresses, but also enables single row needle roller and cage assemblies to accept minimum misalignments up to approximately 1 minute of arc between shaft and housing.

Table 2

Raceway tolerances for needle roller and cage assemblies				
Shaft Nominal diameter (mm)	Tolerances housing/shaft for operational clearance	Shaft diameter		
		over	incl.	
–	80	G6/h5 H6/h5	G6/h5 H6/g5	G6/g6 H6/f6
80	140	G6/h5	G6/g5	G6/f6
140	–	G6/h5 –	G6/g5 H6/f5	G6/f6 H6/e6

Table 3

Matching plan								
Needle roller and cage assembly: K 16×22×13								
Housing bore diameter: 22H6 (mm); deviation 0/+13 μm								
Shaft diameter: 16h5 (mm); deviation 0/–8 μm								
Shaft diameter Deviation group	Housing bore diameter Deviation groups							
	0 to +3 Needle roller gauge limits		+3 to +6 Needle roller gauge limits		+6 to +9 Needle roller gauge limits		+9 to +13 Needle roller gauge limits	
	Radial internal clearance	Radial internal clearance	Radial internal clearance	Radial internal clearance	Radial internal clearance	Radial internal clearance	Radial internal clearance	Radial internal clearance
0 to –3					–5/–7	18–24	–3/–5	17–24
–3 to –6			–5/–7	18–24	–3/–5 –4/–6	17–25	–2/–4	16–25
–6 to –8	–5/–7 –6/–8	18–25	–3/–5 –4/–6	17–24	–2/–4 –3/–5	18–25	0/–2 –1/–3	17–25

Cages

SKF needle roller and cage assemblies have a steel (→ **fig 6**) or sheet steel cage (→ **fig 7**) as standard except for those identified by the designation suffix TN. These have an injection moulded glass fibre reinforced polyamide 6,6 cage (→ **fig 8**).

NB.

Needle roller and cage assemblies with polyamide 6,6 cages can be used at temperatures up to +120 °C. With the exception of a few synthetic oils and greases with a synthetic base oil, and lubricants containing a high proportion of EP additives when used at high temperatures, the lubricants generally used for rolling bearings do not have a detrimental effect on cage properties.

For further information regarding the temperature resistance and use of cages, please refer to the section “Cages” (→ **page 22**).

For bearing arrangements which are to be operated at continuously high temperatures or under arduous conditions, it is recommended that assemblies incorporating steel or sheet steel cages be used.

Raceways on the shaft and in the housing

If the full load carrying capacity of the needle roller and cage assembly is to be exploited the raceways on the shaft and in the housing must have the hardness and surface finish normally found on bearing raceways.

Recommendations for suitable materials, surface roughness and hardness will be found in the section “Raceways on shafts and in housings” (→ **page 28**).

Fig 6

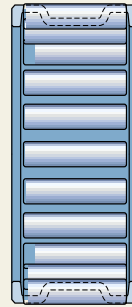
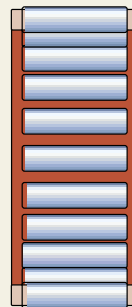

Fig 7



Fig 8



Needle roller and cage assemblies

Abutment dimensions

Needle roller and cage assemblies must be axially guided. The lateral abutment surfaces should be fine turned and possibly polished; for high speed operation they should be hardened and ground. Interruptions in the surface should be avoided. Appropriate values for the abutment diameters on the shaft (→ fig 9) and in the housing (→ fig 10) are given in Table 4. Snap rings may be used in less demanding applications, otherwise an intermediate ring, e.g. a pressed spring steel washer should be placed between the snap ring and the assembly.

Table 4

Abutment dimensions for needle roller and cage assemblies			
Needle roller and cage assembly		Shaft abutment	Housing abutment
Inside diameter	F_w	d_a	D_a
over	incl.		
mm		mm	mm
-	25	$E_w - 0,3$	$F_w + 0,4$
25	65	$E_w - 0,5$	$F_w + 0,5$
65	-	$E_w - 1$	$F_w + 1$

Fig 9

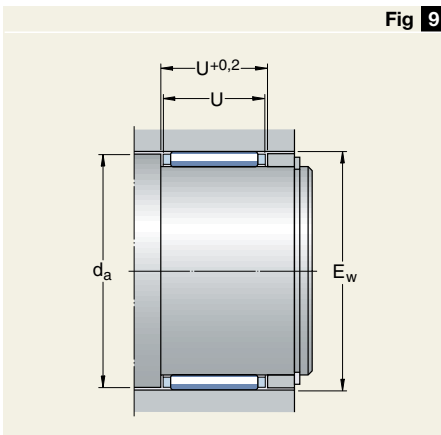
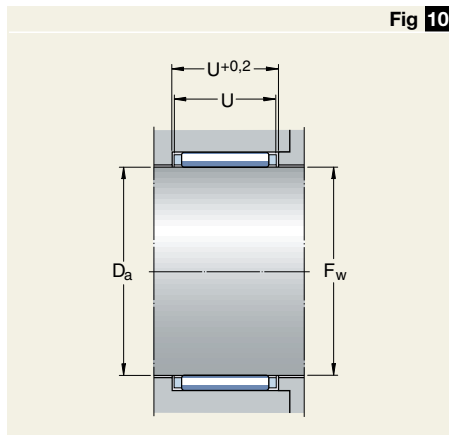

Fig 10



Minimum load

In order to guarantee satisfactory operation, needle roller and cage assemblies, like all ball and roller bearings, must always be subjected to a given minimum load, particularly if they are to operate at high speeds or are subjected to high accelerations or rapid changes in the direction of load. Under such conditions the inertia forces of the needle rollers and cage of the assembly, and the friction in the lubricant, can have a detrimental influence on the rolling conditions in the bearing arrangement and may cause damaging sliding movements to occur between the rollers and raceways.

The requisite minimum radial load to be applied to needle roller and cage assemblies can be estimated using

$$F_{rm} = 0,02 C$$

where

F_{rm} = minimum radial load, N

C = basic dynamic load rating, N

When starting up at low temperatures or when the lubricant is highly viscous, even greater loads may be required. The weights of the components supported by the bearing, together with the external forces, generally exceed the requisite minimum load. If this is not the case, the needle roller and cage assembly must be subjected to an additional radial load.

Equivalent dynamic bearing load

Needle roller and cage assemblies can only take radial loads, therefore

$$P = F_r$$

Equivalent static bearing load

Needle roller and cage assemblies can only take radial loads, therefore

$$P_0 = F_r$$

Supplementary designations

The designation suffixes used to identify certain features of SKF needle roller and cage assemblies are explained in the following.

DS	Split needle roller and cage assembly
DSTN	DS + TN
SORT	Gauge of the needle rollers of an assembly. The figures following indicate the gauge limits in μm , e.g. SORT-1-3
TN	Injection moulded cage of glass fibre reinforced polyamide 6,6
VG052	Split cage of polyether ether ketone (PEEK)
ZW	Double row cage
ZWDSTN	ZW + DS + TN

Needle roller and cage assemblies

F_w 3 – 19 mm

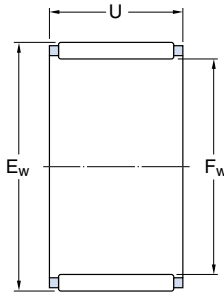

Dimensions			Basic load ratings		Fatigue load limit P_u	Speed ratings		Mass	Designation	Appropriate seal ¹⁾ Designation
F_w	E_w	U	C	C_0		Lubrication grease	oil			
mm			N		N	r/min		g	-	-
3	5	7	1 510	1 340	134	28 000	40 000	0,3	K 3×5×7 TN	-
	5	9	1 720	1 630	170	28 000	40 000	0,4	K 3×5×9 TN	-
	6	7	1 420	1 020	104	28 000	40 000	0,4	K 3×6×7 TN	-
4	7	7	1 720	1 320	137	24 000	36 000	0,5	K 4×7×7 TN	-
	7	10	2 290	1 900	204	24 000	36 000	0,7	K 4×7×10 TN	-
5	8	8	2 290	2 000	212	24 000	36 000	0,7	K 5×8×8 TN	-
	8	10	2 920	2 700	290	24 000	36 000	0,9	K 5×8×10 TN	-
6	9	8	2 550	2 360	250	22 000	34 000	0,8	K 6×9×8 TN	-
	9	10	3 300	3 200	345	22 000	34 000	1,1	K 6×9×10 TN	-
	10	13	3 690	3 150	360	22 000	34 000	1,9	K 6×10×13 TN	G 6×10×2 S
7	9	7	1 680	1 830	190	22 000	34 000	0,6	K 7×9×7 TN	-
	10	8	2 810	2 750	290	20 000	32 000	0,9	K 7×10×8 TN	-
	10	10	3 580	3 750	415	20 000	32 000	1,0	K 7×10×10 TN	-
8	11	8	3 030	3 100	335	20 000	32 000	1,0	K 8×11×8 TN	-
	11	10	3 800	4 250	465	20 000	32 000	1,2	K 8×11×10 TN	-
	11	13	5 010	5 850	670	20 000	32 000	1,7	K 8×11×13 TN	-
	12	10	4 840	4 750	540	19 000	30 000	2,0	K 8×12×10 TN	G 8×12×3
9	12	10	4 400	5 200	570	19 000	30 000	1,5	K 9×12×10 TN	-
	12	13	5 720	7 200	815	19 000	30 000	2,1	K 9×12×13 TN	-
10	13	10	4 570	5 700	630	18 000	28 000	1,6	K 10×13×10 TN	-
	13	13	5 940	8 000	900	18 000	28 000	2,3	K 10×13×13 TN	-
	13	16	6 820	9 500	1 080	18 000	28 000	2,9	K 10×13×16 TN	-
	14	10	5 610	6 100	695	18 000	28 000	2,5	K 10×14×10 TN	G 10×14×3
	14	13	5 830	6 300	720	18 000	28 000	4,6	K 10×14×13 TN	G 10×14×3
	16	12	7 650	7 200	850	18 000	28 000	5,5	K 10×16×12 TN	-
12	15	10	4 730	6 200	695	17 000	26 000	1,9	K 12×15×10 TN	-
	15	13	6 160	8 650	980	17 000	26 000	2,3	K 12×15×13 TN	G 12×16×3
	16	13	7 650	9 500	1 100	17 000	26 000	3,6	K 12×16×13 TN	G 12×16×3
	17	13	9 130	10 400	1 220	17 000	26 000	4,9	K 12×17×13 TN	-
	18	12	9 520	10 000	1 180	17 000	26 000	6,0	K 12×18×12 TN	G/SD 12×18×3

¹⁾ Details of appropriate seals will be found in the section "Seals" (→ page 214)

Dimensions			Basic load ratings		Fatigue load limit P _u	Speed ratings		Mass	Designation	Appropriate seal ¹⁾ Designation
F _w	E _w	U	C	static C ₀		Lubrication grease	oil			
mm			N		N	r/min		g	-	-
14	18	10	6 930	8 650	1 000	16 000	24 000	4,0	K 14×18×10	-
	18	13	7 920	10 200	1 180	16 000	24 000	6,5	K 14×18×13	-
	18	17	10 500	14 600	1 700	16 000	24 000	8,0	K 14×18×17	-
	20	12	9 900	10 600	1 250	16 000	24 000	8,1	K 14×20×12	G/SD 14×20×3
15	18	17	7 650	12 200	1 400	16 000	24 000	4,6	K 15×18×17 TN	-
	19	10	7 210	9 300	1 060	16 000	24 000	5,0	K 15×19×10	-
	19	13	8 250	11 200	1 290	16 000	24 000	7,0	K 15×19×13	-
	19	17	10 800	15 600	1 860	16 000	24 000	9,5	K 15×19×17	-
	20	13	9 520	11 600	1 340	16 000	24 000	7,0	K 15×20×13	-
	21	15	13 800	16 300	2 000	16 000	24 000	11	K 15×21×15	G/SD 15×21×3
	21	21	18 700	24 500	3 000	16 000	24 000	17	K 15×21×21	G/SD 15×21×3
16	20	10	7 480	10 000	1 160	16 000	24 000	5,5	K 16×20×10	-
	20	13	8 580	12 000	1 370	16 000	24 000	7,5	K 16×20×13	-
	20	17	11 200	17 000	2 000	16 000	24 000	10	K 16×20×17	-
	22	12	11 000	12 500	1 500	15 000	22 000	10	K 16×22×12	G/SD 16×22×3
	22	16	14 200	17 600	2 120	15 000	22 000	12	K 16×22×16	G/SD 16×22×3
	22	20	17 600	22 800	2 800	15 000	22 000	17	K 16×22×20	G/SD 16×22×3
	24	20	20 500	23 600	2 900	15 000	22 000	22	K 16×24×20	G/SD 16×24×3
17	21	10	7 810	10 800	1 220	15 000	22 000	5,5	K 17×21×10	-
	21	13	10 100	14 600	1 730	15 000	22 000	6,5	K 17×21×13	-
	21	17	11 700	18 300	2 120	15 000	22 000	9,5	K 17×21×17	-
18	22	10	8 090	11 400	1 320	15 000	22 000	6,0	K 18×22×10	-
	22	13	8 800	12 900	1 500	15 000	22 000	8,0	K 18×22×13	-
	22	17	11 700	18 300	2 160	15 000	22 000	11	K 18×22×17	-
	24	12	12 100	15 000	1 800	14 000	20 000	12	K 18×24×12	G/SD 18×24×3
	24	13	12 500	15 300	1 860	14 000	20 000	13	K 18×24×13	G/SD 18×24×3
	24	20	19 400	27 000	3 250	14 000	20 000	18	K 18×24×20	G/SD 18×24×3
	25	22	22 000	29 000	3 550	14 000	20 000	23	K 18×25×22	-
	28	16	18 700	18 600	2 280	13 000	19 000	24	K 18×28×16	-
19	23	13	9 130	13 700	1 600	14 000	20 000	8,0	K 19×23×13	-
	23	17	12 100	19 300	2 280	14 000	20 000	11	K 19×23×17	-

¹⁾ Details of appropriate seals will be found in the section "Seals" (→ page 214)

Needle roller and cage assemblies

F_w 20 – 37 mm

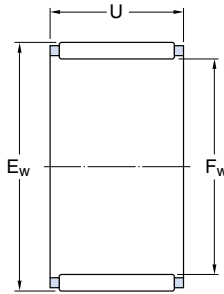

Serie K

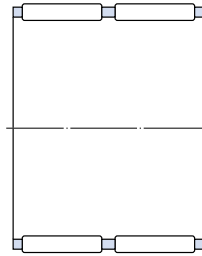

Serie K..ZW

Dimensions			Basic load ratings		Fatigue load limit P _u	Speed ratings		Mass g	Designation	Appropriate seal ¹⁾ Designation
F _w	E _w	U	C	C ₀		Lubrication grease	oil			
mm			N		N	r/min			-	-
20	24	10	8 580	12 900	1 460	14 000	20 000	6,5	K 20×24×10	-
	24	13	9 520	14 600	1 660	14 000	20 000	9,0	K 20×24×13	-
	24	17	12 500	20 800	2 400	14 000	20 000	12	K 20×24×17	-
	26	12	12 800	16 300	1 960	13 000	19 000	11	K 20×26×12	G/SD 20×26×4
	26	13	13 800	18 000	2 160	13 000	19 000	12	K 20×26×13	G/SD 20×26×4
	26	17	18 300	26 000	3 200	13 000	19 000	16	K 20×26×17	G/SD 20×26×4
	26	20	20 100	29 000	3 600	13 000	19 000	19	K 20×26×20	G/SD 20×26×4
	28	20	22 900	28 500	3 450	12 000	18 000	27	K 20×28×20	G/SD 20×28×4
	28	25	29 200	39 000	4 900	12 000	18 000	32	K 20×28×25	G/SD 20×28×4
	30	30	34 100	41 500	5 200	11 000	17 000	49	K 20×30×30	-
21	25	13	9 680	15 300	1 760	13 000	19 000	9,0	K 21×25×13	-
22	26	10	8 800	13 700	1 560	12 000	18 000	7,5	K 22×26×10	-
	26	13	10 100	16 300	1 860	12 000	18 000	9,5	K 22×26×13	-
	26	17	13 200	22 800	2 700	12 000	18 000	12	K 22×26×17	-
	28	17	18 300	27 000	3 250	11 000	17 000	18	K 22×28×17	G/SD 22×28×4
	29	16	19 400	25 500	3 050	11 000	17 000	16	K 22×29×16	-
	30	15	19 000	23 600	2 800	11 000	17 000	18	K 22×30×15 TN	G/SD 22×30×4
23	35	16	24 200	23 200	2 900	9 500	15 000	29	K 23×35×16 TN	-
24	28	10	9 350	15 000	1 730	11 000	17 000	8,5	K 24×28×10	-
	28	13	10 600	18 000	2 080	11 000	17 000	10	K 24×28×13	-
	28	17	14 000	25 500	3 000	11 000	17 000	13	K 24×28×17	-
	30	17	18 700	27 500	3 400	10 000	16 000	19	K 24×30×17	-
	30	31	26 400	43 000	5 300	10 000	16 000	32	K 24×30×31 ZW	-
25	29	10	9 520	15 600	1 800	10 000	16 000	8,5	K 25×29×10	-
	29	13	10 800	18 600	2 160	10 000	16 000	11	K 25×29×13	-
	29	17	14 200	26 500	3 100	10 000	16 000	14	K 25×29×17	-
	30	17	17 900	30 500	3 600	10 000	16 000	16	K 25×30×17	-
	30	20	20 900	36 500	4 400	10 000	16 000	18	K 25×30×20	-
	30	26	20 500	36 000	4 150	10 000	16 000	19	K 25×30×26 ZW	-
	31	17	18 700	28 500	3 450	10 000	16 000	19	K 25×31×17	-
	31	21	23 300	38 000	4 750	10 000	16 000	20	K 25×31×21	-
	32	16	19 800	27 500	3 350	9 500	15 000	21	K 25×32×16	G 25×32×4
	33	20	27 500	38 000	4 650	9 500	15 000	33	K 25×33×20	G 25×33×4
	33	24	31 900	47 500	5 850	9 500	15 000	39	K 25×33×24	G 25×33×4
	35	30	44 600	62 000	7 800	9 500	15 000	65	K 25×35×30	G/SD 25×35×4

¹⁾ Details of appropriate seals will be found in the section "Seals" (→ page 214)

Dimensions			Basic load ratings		Fatigue load limit P _U	Speed ratings		Mass	Designation	Appropriate seal ¹⁾ Designation
F _w	E _w	U	C	static C ₀		Lubrication grease	oil			
mm			N		N	r/min	g	-	-	
26	30	13	11 200	19 600	2 280	10 000	16 000	11	K 26×30×13	-
	30	17	14 700	27 500	3 250	10 000	16 000	15	K 26×30×17	-
	30	22	15 100	29 000	3 350	10 000	16 000	12	K 26×30×22 ZW	-
28	33	13	14 700	24 500	2 850	9 000	14 000	13	K 28×33×13	-
	33	17	19 000	33 500	4 050	9 000	14 000	17	K 28×33×17	-
	34	17	20 900	33 500	4 150	9 000	14 000	24	K 28×34×17	-
	35	16	20 500	30 000	3 550	9 000	14 000	24	K 28×35×16	G/SD 28×35×4
	35	18	22 900	34 500	4 150	9 000	14 000	27	K 28×35×18	G/SD 28×35×4
30	34	13	11 900	22 000	2 550	9 000	14 000	14	K 30×34×13	-
	35	13	15 100	25 500	3 000	8 500	13 000	14	K 30×35×13	-
	35	17	18 700	34 000	4 050	8 500	13 000	19	K 30×35×17	-
	35	27	29 200	60 000	7 350	8 500	13 000	30	K 30×35×27	-
	37	16	22 000	33 500	4 000	8 500	13 000	27	K 30×37×16	G/SD 30×37×4
	37	18	25 100	39 000	4 650	8 500	13 000	30	K 30×37×18	G/SD 30×37×4
	40	18	30 300	40 000	4 900	8 000	12 000	48	K 30×40×18	G/SD 30×40×4
	40	30	46 800	69 500	8 650	8 000	12 000	73	K 30×40×30	G/SD 30×40×4
32	37	13	14 700	25 500	3 000	8 500	13 000	18	K 32×37×13	-
	37	17	19 000	35 500	4 250	8 500	13 000	19	K 32×37×17	-
	37	27	28 600	60 000	7 350	8 500	13 000	30	K 32×37×27	-
	38	20	25 100	45 000	5 600	8 000	12 000	30	K 32×38×20	-
	39	16	22 900	35 500	4 250	8 000	12 000	37	K 32×39×16	-
	39	18	25 500	41 500	5 000	8 000	12 000	31	K 32×39×18	-
	40	25	35 800	58 500	7 200	8 000	12 000	49	K 32×40×25	-
	35	40	13	15 400	28 000	3 250	8 000	12 000	19	K 35×40×13
40		17	19 800	39 000	4 650	8 000	12 000	21	K 35×40×17	-
40		25	28 100	60 000	7 350	8 000	12 000	31	K 35×40×25	-
40		27	23 800	49 000	6 000	8 000	12 000	39	K 35×40×27 TN	-
42		16	23 300	37 500	4 500	7 500	11 000	34	K 35×42×16	G/SD 35×42×4
42		18	26 400	44 000	5 300	7 500	11 000	34	K 35×42×18	G/SD 35×42×4
42		20	29 200	50 000	6 000	7 500	11 000	37	K 35×42×20	G/SD 35×42×4
42		30	37 400	68 000	8 500	7 500	11 000	67	K 35×42×30	G/SD 35×42×4
45		20	35 200	50 000	6 200	7 500	11 000	56	K 35×45×20	G/SD 35×45×4
37		42	17	21 600	43 000	5 200	7 500	11 000	22	K 37×42×17
	45	26	41 800	75 000	9 300	7 500	11 000	61	K 37×45×26	-

¹⁾ Details of appropriate seals will be found in the section "Seals" (→ page 214)

Needle roller and cage assemblies

F_w 38 – 65 mm

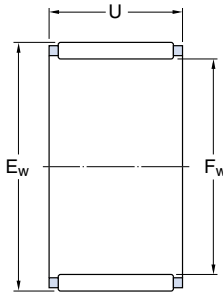

Series K

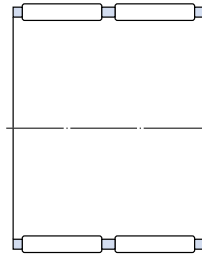

Series K.. ZW

Dimensions			Basic load ratings		Fatigue load limit P _u	Speed ratings		Mass	Designation	Appropriate seal ¹⁾ Designation
F _w	E _w	U	C	C ₀		Lubrication	grease oil			
mm			N		N	r/min		g	-	-
38	43	17	19 800	39 000	4 650	7 500	11 000	29	K 38×43×17	-
	43	27	30 300	68 000	8 300	7 500	11 000	43	K 38×43×27	-
	46	20	34 100	57 000	6 950	7 000	10 000	47	K 38×46×20	-
	46	32	52 300	100 000	12 500	7 000	10 000	76	K 38×46×32	-
39	44	26	26 000	57 000	6 700	7 000	10 000	45	K 39×44×26 ZW	-
40	45	13	16 800	32 500	3 800	7 000	10 000	22	K 40×45×13	-
	45	17	20 500	41 500	5 000	7 000	10 000	31	K 40×45×17	-
	45	27	31 400	73 500	9 000	7 000	10 000	46	K 40×45×27	-
	47	18	28 600	50 000	6 100	7 000	10 000	39	K 40×47×18	G/SD 40×47×4
	48	20	34 700	58 500	7 350	7 000	10 000	49	K 40×48×20	-
42	47	13	17 200	33 500	4 000	7 000	10 000	18	K 42×47×13	-
	47	17	20 900	43 000	5 200	7 000	10 000	32	K 42×47×17	-
	47	30	31 900	76 500	9 000	7 000	10 000	54	K 42×47×30 ZW	-
	50	20	31 900	54 000	7 200	6 700	9 500	53	K 42×50×20	-
43	48	17	20 900	43 000	5 200	6 700	9 500	30	K 43×48×17	-
	48	27	31 900	76 500	9 300	6 700	9 500	50	K 43×48×27	-
45	50	17	21 600	46 500	5 600	6 300	9 000	34	K 45×50×17	-
	50	27	33 000	81 500	10 000	6 300	9 000	51	K 45×50×27	-
	52	18	30 300	57 000	6 950	6 300	9 000	42	K 45×52×18	G/SD 45×52×4
	52	21	28 600	53 000	6 400	6 300	9 000	34	K 45×52×21 TN	G/SD 45×52×4
	53	20	37 400	68 000	8 300	6 300	9 000	55	K 45×53×20	-
	53	21	36 900	67 000	8 300	6 300	9 000	60	K 45×53×21	-
	53	28	49 500	98 000	12 200	6 300	9 000	81	K 45×53×28	-
59	18	44 000	53 000	6 550	6 000	8 500	72	K 45×59×18 TN	-	
47	52	17	22 400	49 000	6 000	6 300	9 000	35	K 47×52×17	-
	52	27	33 600	83 000	10 200	6 300	9 000	51	K 47×52×27	-
	53	25	36 900	81 500	10 200	6 000	8 500	51	K 47×53×25	-

¹⁾ Details of appropriate seals will be found in the section "Seals" (→ page 214)

Dimensions			Basic load ratings		Fatigue load limit P _u	Speed ratings		Mass	Designation	Appropriate seal ¹⁾ Designation
F _w	E _w	U	C	C ₀		Lubrication grease	oil			
mm			N		N	r/min		g	-	-
50	55	13,5	17 600	36 500	4 300	6 000	8 500	30	K 50×55×13,5	-
	55		17	21 200	47 500	5 700	6 000	8 500	35	K 50×55×17
	55	20	25 500	60 000	7 200	6 000	8 500	43	K 50×55×20	-
	55	30	37 400	98 000	12 000	6 000	8 500	65	K 50×55×30	-
	57	18	31 900	64 000	7 800	5 600	8 000	47	K 50×57×18	-
	58	20	34 100	62 000	7 650	5 600	8 000	75	K 50×58×20	G/SD 50×58×4
	58	25	41 800	81 500	10 200	5 600	8 000	90	K 50×58×25	G/SD 50×58×4
52	57	12	17 200	36 500	4 300	5 600	8 000	24	K 52×57×12	-
55	60	20	27 000	67 000	8 150	5 300	7 500	40	K 55×60×20	-
	60	27	35 800	96 500	12 000	5 300	7 500	60	K 55×60×27	-
	60	30	39 600	108 000	13 400	5 300	7 500	71	K 55×60×30	-
	62	18	34 100	71 000	8 500	5 300	7 500	52	K 55×62×18	-
	63	15	25 500	40 500	4 900	5 300	7 500	53	K 55×63×15	-
	63	20	38 000	75 000	9 150	5 300	7 500	67	K 55×63×20	-
	63	25	48 400	102 000	12 700	5 300	7 500	80	K 55×63×25	-
63	32	59 400	129 000	16 300	5 300	7 500	100	K 55×63×32	-	
58	65	18	33 600	71 000	8 650	5 000	7 000	52	K 58×65×18	-
	65	36	47 300	108 000	12 900	5 000	7 000	125	K 58×65×36 ZW	-
60	65	20	28 100	72 000	8 800	5 000	7 000	52	K 60×65×20	-
	65	30	41 300	116 000	14 300	5 000	7 000	77	K 60×65×30	-
	66	33	44 000	112 000	13 700	5 000	7 000	105	K 60×66×33 ZW	-
	66	40	55 000	150 000	18 600	5 000	7 000	115	K 60×66×40 ZW	-
	68	20	41 800	86 500	10 600	4 800	6 700	71	K 60×68×20	-
	68	23	47 300	102 000	12 500	4 800	6 700	94	K 60×68×23	-
	68	25	51 200	112 000	14 000	4 800	6 700	89	K 60×68×25	-
	68	30	42 900	88 000	10 600	4 800	6 700	130	K 60×68×30 ZW	-
	75	42	112 000	196 000	25 000	4 500	6 300	240	K 60×75×42	-
62	70	40	62 700	146 000	18 600	4 800	6 700	175	K 62×70×40 ZW	-
64	70	16	26 400	60 000	7 350	4 500	6 300	53	K 64×70×16	-
65	70	20	29 200	76 500	9 300	4 500	6 300	56	K 65×70×20	-
	70	30	41 800	125 000	15 300	4 500	6 300	83	K 65×70×30	-
	73	23	41 800	90 000	11 800	4 500	6 300	110	K 65×73×23	-
	73	30	53 900	125 000	15 600	4 500	6 300	140	K 65×73×30	-

¹⁾ Details of appropriate seals will be found in the section "Seals" (→ page 214)

Needle roller and cage assemblies

F_w 68 – 265 mm

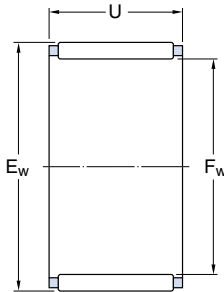

Dimensions			Basic load ratings		Fatigue load limit P _u	Speed ratings		Mass	Designation	Appropriate seal ¹⁾ Designation
F _w	E _w	U	C	C ₀		Lubrication grease	oil			
mm			N		N	r/min		g	-	-
68	74	20	33 600	83 000	10 400	4 300	6 000	71	K 68×74×20	-
	74	30	44 600	118 000	15 000	4 300	6 000	100	K 68×74×30	-
70	76	20	34 100	86 500	10 600	4 300	6 000	71	K 70×76×20	-
	76	30	50 100	140 000	17 600	4 300	6 000	110	K 70×76×30	-
	78	25	49 500	112 000	14 000	4 300	6 000	120	K 70×78×25	G 70×78×5
	78	30	57 200	137 000	17 000	4 300	6 000	150	K 70×78×30	G 70×78×5
72	80	20	39 600	85 000	10 600	4 000	5 600	98	K 72×80×20	-
73	79	20	35 200	90 000	11 200	4 000	5 600	75	K 73×79×20	-
75	81	20	35 800	93 000	11 600	4 000	5 600	79	K 75×81×20	-
	81	30	50 100	143 000	18 000	4 000	5 600	115	K 75×81×30	-
	83	23	47 300	110 000	13 700	3 800	5 300	125	K 75×83×23	-
	83	30	59 400	143 000	18 000	3 800	5 300	145	K 75×83×30	-
80	86	20	36 900	98 000	12 200	3 800	5 300	60	K 80×86×20	-
	86	30	53 900	160 000	20 000	3 800	5 300	79	K 80×86×30	-
	88	30	68 200	176 000	22 000	3 600	5 000	140	K 80×88×30	-
85	92	20	42 900	108 000	13 200	3 400	4 800	100	K 85×92×20	-
90	97	20	42 900	114 000	13 700	3 200	4 500	110	K 90×97×20	-
	98	27	58 300	150 000	18 600	3 200	4 500	150	K 90×98×27	-
	98	30	64 400	173 000	21 600	3 200	4 500	170	K 90×98×30	-
95	103	30	66 000	180 000	22 800	3 000	4 300	165	K 95×103×30	-
100	107	21	45 700	127 000	15 300	2 800	4 000	120	K 100×107×21	-
	108	27	55 000	143 000	17 600	2 800	4 000	185	K 100×108×27	-
	108	30	67 100	190 000	23 600	2 800	4 000	180	K 100×108×30	-
105	112	21	45 700	129 000	15 300	2 800	4 000	130	K 105×112×21	-
110	117	24	53 900	160 000	18 600	2 600	3 800	170	K 110×117×24	-
	118	30	73 700	220 000	26 500	2 600	3 800	215	K 110×118×30	-
115	123	27	60 500	170 000	20 000	2 400	3 600	200	K 115×123×27	-

¹⁾ Details of appropriate seals will be found in the section "Seals" (→ page 214)

Dimensions			Basic load ratings		Fatigue load limit P_u	Speed ratings		Mass	Designation
F_w	E_w	U	dynamic C	static C_0		Lubrication grease oil			
mm			N		N	r/min		g	–
120	127	24	56 100	176 000	20 400	2 200	3 400	165	K 120×127×24
125	133	35	82 500	260 000	30 500	2 000	3 200	275	K 125×133×35
130	137	24	58 300	186 000	21 200	2 000	3 200	170	K 130×137×24
135	143	35	88 000	290 000	33 500	1 900	3 000	300	K 135×143×35
145	153	26	70 400	224 000	25 000	1 800	2 800	260	K 145×153×26
	153	36	93 500	325 000	36 500	1 800	2 800	300	K 145×153×36
150	160	46	140 000	475 000	53 000	1 800	2 800	570	K 150×160×46
155	163	26	72 100	236 000	25 500	1 700	2 600	265	K 155×163×26
	163	36	95 200	340 000	37 500	1 700	2 600	360	K 155×163×36
160	170	46	145 000	510 000	56 000	1 700	2 600	550	K 160×170×46
165	173	26	76 500	265 000	28 500	1 600	2 400	320	K 165×173×26
175	183	32	95 200	355 000	37 500	1 600	2 400	400	K 175×183×32
185	195	37	123 000	425 000	45 000	1 500	2 200	605	K 185×195×37
195	205	37	125 000	450 000	46 500	1 400	2 000	620	K 195×205×37
210	220	42	147 000	560 000	57 000	1 300	1 900	740	K 210×220×42
220	230	42	151 000	585 000	58 500	1 200	1 800	790	K 220×230×42
240	250	42	157 000	630 000	62 000	1 100	1 700	850	K 240×250×42
265	280	50	242 000	850 000	83 000	950	1 500	1 800	K 265×280×50



Drawn cup needle roller bearings

Product tables page 56

SKF drawn cup needle roller bearings, as the name suggests, are needle roller bearings with a deep drawn thin-walled outer ring with open or closed end. They are characterised by very low sectional height and high load carrying capacity. They are used when the housing bore cannot be used as a raceway for a needle roller and cage assembly but where a very compact and economic bearing arrangement is required. They are pressed into the housing bore and, if shoulders or retaining rings are not required for axial location, the design of the housing bore is simple and can be economically produced.

Drawn cup needle roller bearings are available with open ends (→ **fig 1**) or with closed end (→ **fig 2**). The latter are suitable for bearing arrangements at the ends of shafts. The profiled design of the closed end also permits small axial guidance forces to be accommodated.

3

Fig 1

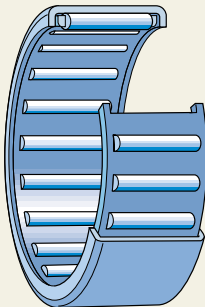
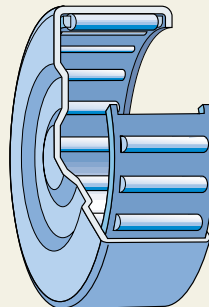

Fig 2



Drawn cup needle roller bearings

Drawn cup needle roller bearings are generally used directly on the shaft. However, in cases where the shaft cannot be hardened and ground, they can be combined with an inner ring (→ **fig 3**).

The drawn cup of hardened sheet steel and the needle roller and cage assembly of these bearings form a non-separable unit. The outside surface of the rollers is slightly relieved towards the roller ends; this gives a favourable load distribution in the bearing. The space available for lubricant is large enough to allow long relubrication intervals to be applied.

Normally, drawn cup needle roller bearings have a single row of rollers. However, the relatively wide sizes incorporate two needle roller and cage assemblies immediately adjacent to each other and have a lubrication hole in the outer ring (→ **fig 4**). On request, any single row drawn cup needle roller bearing for shaft diameters of 7 mm and above can be supplied with a lubrication hole in the outer ring (→ **fig 5**).

Fig 3

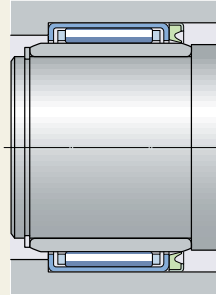

Fig 4

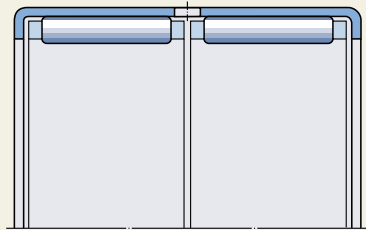
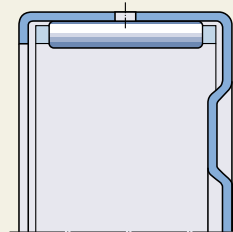

Fig 5



Sealed drawn cup needle roller bearings

For applications where a sufficiently efficient seal is not available, or cannot be used for space reasons, drawn cup needle roller bearings can also be supplied with integral seals as follows:

- drawn cup needle roller bearing with open ends, sealed at one side (→ **fig 6**);
- drawn cup needle roller bearing with open ends, sealed at both sides (→ **fig 7**);
- sealed drawn cup needle roller bearing with closed end (→ **fig 8**).

The integral seals are rubbing seals of polyurethane or nitrile rubber (NBR) which, under normal conditions, effectively exclude solid contaminants and moisture and retain the lubricant in the bearing.

Sealed drawn cup needle roller bearings are supplied as standard filled with a high quality lithium base grease of consistency 2 to the NLGI Scale. The grease has good rust inhibiting properties and can be used at temperatures between -30 and $+100$ °C. The relatively large quantity of grease in the bearings means that they can be operated for long periods before relubrication is required.

Fig 6

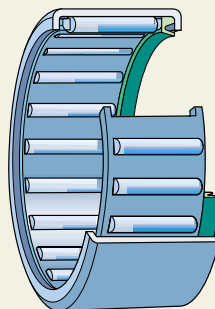

Fig 7

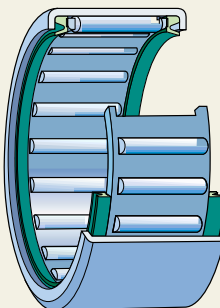
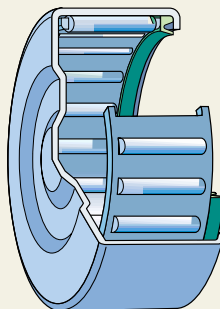

Fig 8



3

Drawn cup needle roller bearings

Universal joint bearings

For the universal joints of commercial vehicle propeller shafts, SKF has developed a drawn cup needle roller bearing with closed end (→ fig 9). The bearing has high dynamic load carrying capacity and other design refinements. Several sizes are available in the inside diameter range 20 to 48 mm.

The thin-walled, case hardened drawn cup allows the use of relatively large diameter rollers giving high load carrying capacity while still permitting compact bearing arrangements. Other advantages include high axial load carrying capacity without risk of rupture of the base of the drawn cup and good damping of axial shocks by the integral thrust washer of glass fibre reinforced plastic.

The cup spring between the roller ends and seal reduces the risk of false brinelling as it aligns the rollers in the unloaded zone and causes the roller complement to continue rotating.

The integral seals of nitrile rubber (NBR) efficiently prevent dirt and water from penetrating the bearing and retain the lubricating grease in the bearing, thus rendering the bearing maintenance-free.

Further information will be supplied on request.

Dimensions

The boundary dimensions of the drawn cup needle roller bearings are in accordance with ISO 3245:1997.

Tolerances

The dimensional accuracy of drawn cup needle roller bearings cannot be checked until they have been mounted as the thin-walled outer ring may be slightly out-of-round. Only after the bearing has been pressed into a housing bore having the recommended tolerance will the outer ring obtain its correct form, which is decisive for bearing performance. If it is desired to check the inside diameter F_w of the roller set, the bearing must first be pressed into a thick-walled ring having a bore diameter as shown in Table 1. A measuring mandrel can then be used to check the inside diameter deviation. The permissible deviations are also given in Table 1.

Fig 9

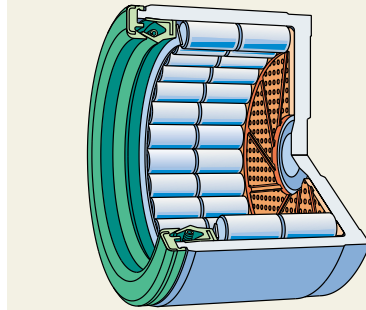

Table 1

Tolerances for drawn cup needle roller bearings				
Bearing Inside diameter F_w	Outside diameter D	Gauge ring Bore diameter (measured)	Deviations from nominal inside diameter	
			high	low
mm	mm	mm	μm	
3	6,5	6,484	+24	+6
4	8	7,984	+28	+10
5	9	8,984	+28	+10
6	10	9,984	+28	+10
7	11	10,980	+31	+13
8	12	11,980	+31	+13
9	13	12,980	+31	+13
10	14	13,980	+31	+13
12	16	15,980	+34	+16
12	18	17,980	+34	+16
13	19	18,976	+34	+16
14	20	19,976	+34	+16
15	21	20,976	+34	+16
16	22	21,976	+34	+16
17	23	22,976	+34	+16
18	24	23,976	+34	+16
20	26	25,976	+41	+20
22	28	27,976	+41	+20
25	32	31,972	+41	+20
28	35	34,972	+41	+20
30	37	36,972	+41	+20
35	42	41,972	+50	+25
40	47	46,972	+50	+25
45	52	51,967	+50	+25
50	58	57,967	+50	+25
55	63	62,967	+60	+30
60	68	67,967	+60	+30

The width tolerance is a uniform 0/-0,3 mm for all sizes of drawn cup needle roller bearings.

Paired mounting

If drawn cup needle roller bearings are to be mounted immediately adjacent to each other, the deviations from the nominal internal diameter must be the same for both bearings if they are to carry the load equally.

Misalignment

The modified line contact between the raceways and the needle rollers not only prevents damaging edge stresses but also enables single row drawn cup needle roller bearings to accept minimum misalignments between shaft and housing.

Cages

SKF drawn cup needle roller bearings incorporate a sheet steel cage (→ **fig 10**) as standard except for those identified by the designation suffix TN. These have an injection moulded glass fibre reinforced polyamide 6,6 cage (→ **fig 11**).

NB.

Drawn cup needle roller bearings with polyamide 6,6 cages can be used at temperatures up to +120 °C. With the exception of a few synthetic oils and greases with a synthetic base oil, and lubricants containing a

high proportion of EP additives when used at high temperatures, the lubricants generally used for rolling bearings do not have a detrimental effect on cage properties.

For further information regarding the temperature resistance and use of cages, please refer to the section “Cages” (→ **page 22**).

For bearing arrangements which are to be operated at continuously high temperatures or under arduous conditions, it is recommended that bearings incorporating sheet steel cages be used.

Fig 10

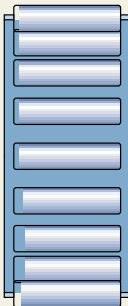

Fig 11



Drawn cup needle roller bearings

Shaft and housing tolerances

It is particularly important for drawn cup needle roller bearings that the housing bore has good accuracy of dimensions and form. If the values given in **Table 2** are adhered to then the bearings will obtain the necessary interference fit in the housing. The inside diameter (diameter under the rollers) will then be approximately within tolerance F8. This, together with the recommended shaft tolerance which is also given in **Table 2**, will result in a normal radial internal clearance in the bearing arrangement. The cylindricity of the housing bore should be within IT5/2.

Raceways on the shaft

If the full load carrying capacity of drawn cup needle roller bearings is to be exploited, the raceways on the shaft must have the hardness and surface finish normally found on bearing raceways. Recommendations will be found in the section "Raceways on shafts and in housings" (→ **page 28**).

Mounting instructions

The best way to mount drawn cup needle roller bearings is to use a mounting dolly (→ **fig 12**). The bearing can be held in position by an O-ring. The stamped side face of drawn cup needle roller bearings should preferably abut the flange of the mounting dolly.

Special care should be taken to see that the bearings do not skew or tilt when they are being pressed into the housing.

Table 2

Shaft and housing tolerances			
Housing material ¹⁾	Tolerances		
	Housing bore seating ²⁾	Raceway on the shaft	Shaft seating for inner ring
Steel, cast iron	N6	h5	k5
	N7	h6	j6
Light alloy	R6	h5	k5
	R7	h6	j6

1) For housings which are not rigid, the shaft tolerance giving the desired operational clearance must be determined by trial and error

2) The accuracy of cylindrical form to ISO 1101-1985 for the housing bore must correspond to tolerance IT5/2

Fig 12

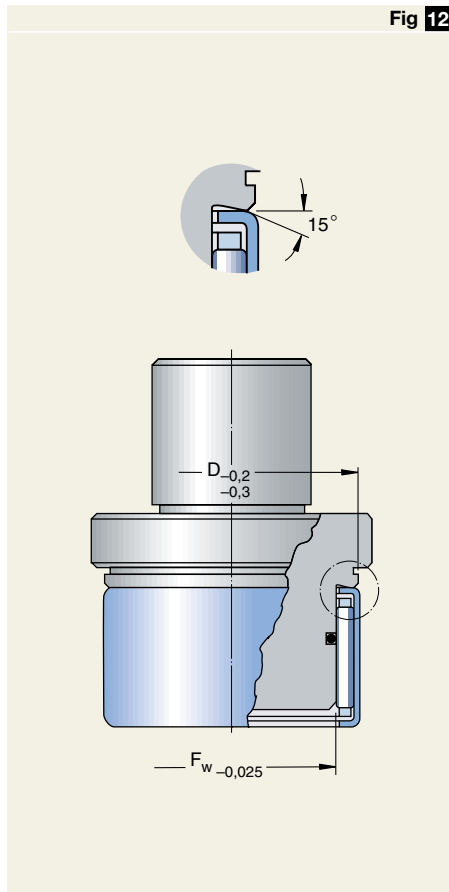

Minimum load

In order to guarantee satisfactory operation, drawn cup needle roller bearings, like all ball and roller bearings, must always be subjected to a given minimum load, particularly if they are to operate at high speeds or are subjected to high accelerations or rapid changes in the direction of load. Under such conditions the inertia forces of the needle rollers and cage of drawn cup needle roller bearings, and the friction in the lubricant, can have a detrimental influence on the rolling conditions in the bearing arrangement and may cause damaging sliding movements to occur between the rollers and raceways.

The requisite minimum radial load to be applied to drawn cup needle roller bearings can be estimated using

$$F_{rm} = 0,02 C$$

where

F_{rm} = minimum radial load, N

C = basic dynamic load rating, N

When starting up at low temperatures or when the lubricant is highly viscous, even greater loads may be required. The weights of the components supported by the bearing, together with the external forces, generally exceed the requisite minimum load. If this is not the case, the drawn cup needle roller bearing must be subjected to an additional radial load.

Equivalent dynamic bearing load

Drawn cup needle roller bearings can only take radial loads, therefore

$$P = F_r$$

Equivalent static bearing load

Drawn cup needle roller bearings can only take radial loads, therefore

$$P_0 = F_r$$

Static load carrying capacity

It should be observed that a static safety factor of 3 or larger should be applied, i.e.

$$s_0 = C_0/P_0 \geq 3.$$

Supplementary designations

The designation suffixes used to identify certain features of SKF drawn cup needle roller bearings are explained in the following.

AS1	One lubrication hole in the outer ring
RS	Seal at one side of the bearing
2RS	Seal at both sides of drawn cup needle roller bearing with open ends
SM03	Lithium base grease of consistency 2 for operating temperatures of -25 to $+150$ °C
TN	Injection moulded cage of glass fibre reinforced polyamide 6,6

Drawn cup needle roller bearings

F_w 3 – 10 mm

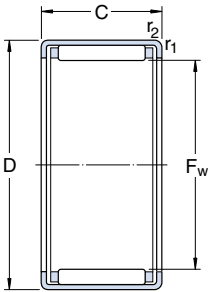

With open ends
Series HK

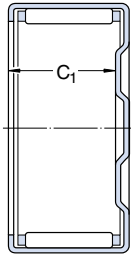

With closed end
Series BK

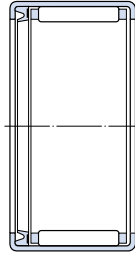

With open ends
and one seal
Series HK .. RS

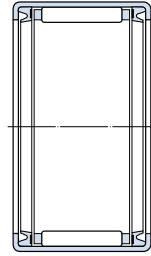

With open ends
and two seals
Series HK .. 2RS

Principal dimensions			Basic load ratings		Fatigue load limit P _u	Speed ratings		Mass g	Designation
F _w	D	C	C	C ₀		Lubrication grease	oil		
mm			N		N	r/min			-
3	6,5	6	1 230	880	88	30 000	43 000	1,0	HK 0306 TN
	6,5	6	1 230	880	88	30 000	43 000	1,0	BK 0306 TN
4	8	8	1 760	1 370	140	26 000	38 000	2,0	HK 0408
	8	8	1 760	1 370	140	26 000	38 000	2,1	BK 0408
5	9	9	2 380	2 080	220	22 000	34 000	2,0	HK 0509
	9	9	2 380	2 080	220	22 000	34 000	2,1	BK 0509
6	10	8	2 010	1 730	180	20 000	32 000	2,1	HK 0608
	10	9	2 810	2 700	285	20 000	32 000	2,5	HK 0609
	10	9	2 810	2 700	285	20 000	32 000	2,6	BK 0609
7	11	9	3 030	3 050	325	18 000	28 000	2,6	HK 0709
	11	9	3 030	3 050	325	18 000	28 000	2,9	BK 0709
8	12	8	2 700	2 750	285	17 000	26 000	2,7	HK 0808
	12	8	2 700	2 750	285	17 000	26 000	3,0	BK 0808
	12	10	3 690	4 050	440	17 000	26 000	3,0	HK 0810
	12	10	2 700	2 750	285	14 000	-	3,0	HK 0810 RS
	12	10	3 690	4 050	440	17 000	26 000	3,4	BK 0810
	12	12	2 700	2 750	285	14 000	-	3,3	HK 0812.2RS
9	13	8	3 520	3 900	415	16 000	24 000	3,0	HK 0908
	13	10	4 130	4 800	530	16 000	24 000	4,0	HK 0910
	13	10	4 130	4 800	530	16 000	24 000	4,3	BK 0910
	13	12	5 120	6 400	720	16 000	24 000	4,6	HK 0912
	13	12	5 120	6 400	720	16 000	24 000	4,9	BK 0912
10	14	10	4 290	5 300	570	16 000	24 000	4,1	HK 1010
	14	10	4 290	5 300	570	16 000	24 000	4,3	BK 1010
	14	12	5 390	6 950	780	16 000	24 000	4,8	HK 1012
	14	12	4 290	5 300	570	13 000	-	4,2	HK 1012 RS
	14	12	5 390	6 950	780	16 000	24 000	5,0	BK 1012
	14	14	4 290	5 300	570	13 000	-	4,6	HK 1014.2RS
	14	15	6 600	9 000	1 020	16 000	24 000	6,0	HK 1015
	14	15	6 600	9 000	1 020	16 000	24 000	6,2	BK 1015

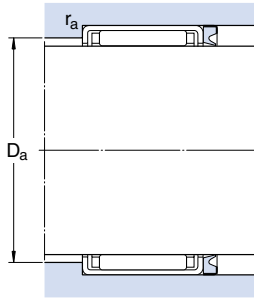

Dimensions			Abutment and fillet dimensions		Appropriate inner ring ¹⁾ Designation	seal ¹⁾ Designation
F _w	C ₁	r _{1,2} min	D _a max	r _a max		
mm			mm		-	
3	-	0,3	3,5	0,3	-	-
	5,2	0,3	3,5	0,3	-	-
4	-	0,3	5	0,3	-	G 4×8×2 S
	6,4	0,3	5	0,3	-	G 4×8×2 S
5	-	0,4	5,3	0,4	-	G 5×9×2 S
	7,2	0,4	5,3	0,4	-	G 5×9×2 S
6	-	0,4	6,3	0,4	-	G 6×10×2 S
	-	0,4	6,3	0,4	-	G 6×10×2 S
	7,4	0,4	6,3	0,4	-	G 6×10×2 S
7	-	0,4	7,3	0,4	-	G 7×11×2 S
	7,4	0,4	7,3	0,4	-	G 7×11×2 S
8	-	0,4	8,3	0,4	-	G 8×12×3
	6,4	0,4	8,3	0,4	-	G 8×12×3
	-	0,4	8,3	0,4	IR 5×8×12	G 8×12×3
	-	0,4	8,3	0,4	IR 5×8×12	-
	8,4	0,4	8,3	0,4	IR 5×8×12	G 8×12×3
	-	0,4	8,3	0,4	IR 5×8×16	-
9	-	0,4	9,3	0,4	-	G 9×13×3
	-	0,4	9,3	0,4	IR 6×9×12	G 9×13×3
	8,2	0,4	9,3	0,4	IR 6×9×12	G 9×13×3
	-	0,4	9,3	0,4	IR 6×9×12	G 9×13×3
	10,4	0,4	9,3	0,4	IR 6×9×12	G 9×13×3
10	-	0,4	10,3	0,4	IR 7×10×10,5	G 10×14×3
	8,4	0,4	10,3	0,4	IR 7×10×10,5	G 10×14×3
	-	0,4	10,3	0,4	IR 7×10×12	G 10×14×3
	-	0,4	10,3	0,4	-	-
	10,4	0,4	10,3	0,4	IR 7×10×12	G 10×14×3
	-	0,4	10,3	0,4	IR 7×10×16	-
	-	0,4	10,3	0,4	IR 7×10×16	G 10×14×3
	13,4	0,4	10,3	0,4	IR 7×10×16	G 10×14×3

¹⁾Details of appropriate inner rings and seals will be found in the sections "Inner rings" (→ page 204) and "Seals" (→ page 214)

Drawn cup needle roller bearings

F_w 12 – 17 mm

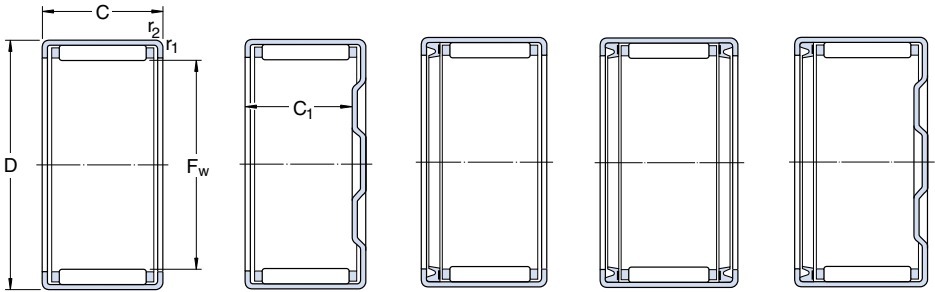

With open ends
Series HK

With closed end
Series BK

With open ends
and one seal
Series HK .. RS

With open ends
and two seals
Series HK .. 2RS

With closed end
and one seal
Series BK .. RS

Principal dimensions			Basic load ratings		Fatigue load limit P _u	Speed ratings		Mass g	Designation	
F _w	D	C	dynamic C	static C ₀		Lubrication grease	oil			
mm			N		N	r/min			-	
12	16	10	4 840	6 400	710	14 000	20 000	4,6	HK 1210	
	16	10	4 840	6 400	710	14 000	20 000	5,2	BK 1210	
	18	12	6 270	7 350	850	14 000	20 000	9,0	HK 1212	
	18	12	6 270	7 350	850	14 000	20 000	10	BK 1212	
	18	14	6 270	7 350	850	12 000	-	10	HK 1214 RS	
	18	16	6 270	7 350	850	12 000	-	11	HK 1216.2RS	
13	19	12	6 600	8 000	915	13 000	19 000	10	HK 1312	
	19	12	6 600	8 000	915	13 000	19 000	11	BK 1312	
14	20	12	6 820	8 650	980	12 000	18 000	11	HK 1412	
	20	12	6 820	8 650	980	12 000	18 000	12	BK 1412	
	20	14	6 820	8 650	980	11 000	-	12	HK 1414 RS	
	20	14	6 820	8 650	980	11 000	-	13	BK 1414 RS	
	20	16	6 820	8 650	980	11 000	-	13	HK 1416.2RS	
15	21	12	7 650	9 500	1 080	11 000	17 000	11	HK 1512	
	21	12	7 650	9 500	1 080	11 000	17 000	13	BK 1512	
	21	14	7 480	10 000	1 140	11 000	-	12	HK 1514 RS	
	21	16	10 100	14 600	1 700	11 000	17 000	15	HK 1516	
	21	16	7 480	10 000	1 140	11 000	-	15	HK 1516.2RS	
	21	16	10 100	14 600	1 700	11 000	17 000	17	BK 1516	
	21	18	10 100	14 600	1 700	11 000	-	16	HK 1518 RS	
	21	20	10 100	14 600	1 700	11 000	-	18	HK 1520.2RS	
	21	22	13 000	20 000	2 280	11 000	17 000	20	HK 1522 ¹⁾	
	16	22	12	7 370	9 800	1 120	10 000	16 000	12	HK 1612
22		12	7 370	9 800	1 120	10 000	16 000	14	BK 1612	
22		14	7 370	9 800	1 120	10 000	-	13	HK 1614 RS	
22		14	7 370	9 800	1 120	10 000	-	15	BK 1614 RS	
22		16	10 500	15 600	1 800	10 000	16 000	16	HK 1616	
22		16	7 370	9 800	1 120	10 000	-	14	HK 1616.2RS	
22		16	10 500	15 600	1 800	10 000	16 000	18	BK 1616	
22		20	11 000	14 600	1 660	10 000	-	18	HK 1620.2RS	
22		22	12 800	19 600	2 240	10 000	16 000	22	HK 1622 ¹⁾	
22		22	12 800	19 600	2 240	10 000	16 000	24	BK 1622 ¹⁾	
17		23	12	7 650	10 600	1 200	10 000	16 000	12	HK 1712

¹⁾ Double row

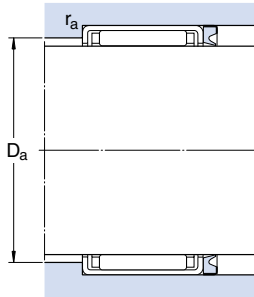

Dimensions			Abutment and fillet dimensions		Appropriate inner ring ¹⁾ Designation	seal ¹⁾ Designation
F _w	C ₁	r _{1,2} min	D _a max	r _a max		
mm			mm		-	
12	-	0,4	12,3	0,4	IR 8×12×10.5	G 12×16×3
	8,4	0,4	12,3	0,4	IR 8×12×10.5	G 12×16×3
		0,8	13	0,8	IR 8×12×12.5	G/SD 12×18×3
	9,3	0,8	13	0,8	IR 8×12×12.5	G/SD 12×18×3
		0,8	13	0,8	LR/IR 8×12×12.5	-
-	0,8	13	0,8	-	-	
13	-	0,8	14	0,8	IR 10×13×12.5	G/SD 13×19×3
	9,3	0,8	14	0,8	IR 10×13×12.5	G/SD 13×19×3
14	-	0,8	15	0,8	IR 10×14×13	G/SD 14×20×3
	9,3	0,8	15	0,8	IR 10×14×13	G/SD 14×20×3
		0,8	15	0,8	IR 10×14×16	-
	11,3	0,8	15	0,8	IR 10×14×13	-
		0,8	15	0,8	IR 10×14×20	-
15	-	0,8	16	0,8	IR 12×15×12.5	G/SD 15×21×3
	9,3	0,8	16	0,8	IR 12×15×12.5	G/SD 15×21×3
		0,8	16	0,8	LR 12×15×16.5	-
	-	0,8	16	0,8	IR 12×15×16.5	G/SD 15×21×3
	-	0,8	16	0,8	LR/IR 12×15×16.5	-
	13,3	0,8	16	0,8	IR 12×15×16.5	G/SD 15×21×3
		0,8	16	0,8	-	-
	-	0,8	16	0,8	LR/IR 12×15×22.5	-
	-	0,8	16	0,8	IR 12×15×22.5	G/SD 15×21×3
16	-	0,8	17	0,8	IR 12×16×13	G/SD 16×22×3
	9,3	0,8	17	0,8	IR 12×16×13	G/SD 16×22×3
		0,8	17	0,8	IR 12×16×16	-
	11,3	0,8	17	0,8	IR 12×16×13	-
		0,8	17	0,8	IR 12×16×16	G/SD 16×22×3
	-	0,8	17	0,8	IR 12×16×20	-
	13,3	0,8	17	0,8	IR 12×16×16	G/SD 16×22×3
		0,8	17	0,8	IR 12×16×22	-
	-	0,8	17	0,8	IR 12×16×22	G/SD 16×22×3
	19,3	0,8	17	0,8	IR 12×16×22	G/SD 16×22×3
17	-	0,8	18	0,8	-	G/SD 17×23×3

¹⁾ Details of appropriate inner rings and seals will be found in the sections "Inner rings" (→ page 204) and "Seals" (→ page 214)



Drawn cup needle roller bearings

F_w 18 – 25 mm

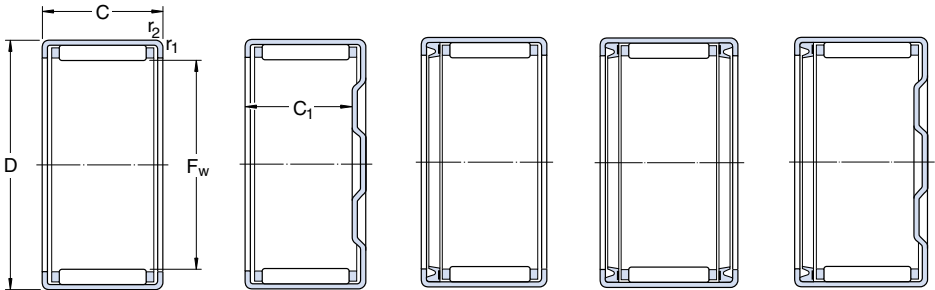

With open ends
Series HK

With closed end
Series BK

With open ends
and one seal
Series HK .. RS

With open ends
and two seals
Series HK .. 2RS

With closed end
and one seal
Series BK .. RS

Principal dimensions	Basic load ratings		Fatigue load limit P _u	Speed ratings		Mass	Designation		
	dynamic	static		Lubrication	oil				
F _w D C	C	C ₀		grease		g	-		
mm	N		N	r/min					
18	24	12	7 920	11 200	1 270	9 500	15 000	13	HK 1812
	24	12	7 920	11 200	1 270	9 500	15 000	15	BK 1812
	24	14	7 920	11 200	1 270	9 500	-	14	HK 1814 RS
	24	16	11 200	17 600	2 040	9 500	15 000	18	HK 1816
	24	16	7 920	11 200	1 270	9 500	-	15	HK 1816.2RS
	24	16	11 200	17 600	2 040	9 500	15 000	20	BK 1816
20	26	10	6 160	8 500	930	9 000	14 000	12	HK 2010
	26	12	8 420	12 500	1 400	9 000	14 000	14	HK 2012
	26	16	12 300	20 400	2 360	9 000	14 000	19	HK 2016
	26	16	8 420	12 500	1 400	9 000	-	18	HK 2016.2RS
	26	16	12 300	20 400	2 360	9 000	14 000	22	BK 2016
	26	18	12 300	20 400	2 360	9 000	-	21	HK 2018 RS
	26	18	12 300	20 400	2 360	9 000	-	24	BK 2018 RS
	26	20	15 100	26 500	3 150	9 000	14 000	24	HK 2020
	26	20	12 300	20 400	2 360	9 000	-	23	HK 2020.2RS
	26	20	15 100	26 500	3 150	9 000	14 000	27	BK 2020¹⁾
	26	30	20 900	40 500	4 750	9 000	14 000	35	HK 2030¹⁾
	22	28	10	7 210	10 600	1 200	8 000	12 000	13
28		12	8 800	13 700	1 560	8 000	12 000	15	HK 2212
28		12	8 800	13 700	1 560	8 000	12 000	18	BK 2212
28		14	8 800	13 700	1 560	8 000	-	16	HK 2214 RS
28		16	13 000	22 400	2 600	8 000	12 000	21	HK 2216
28		16	8 800	13 700	1 560	8 000	-	18	HK 2216.2RS
28		16	13 000	22 400	2 600	8 000	12 000	24	BK 2216
28		18	13 000	22 400	2 600	8 000	-	24	HK 2218 RS
28		20	15 700	29 000	3 450	8 000	12 000	26	HK 2220
28		20	13 000	22 400	2 600	8 000	-	26	HK 2220.2RS
25	32	12	10 500	15 300	1 760	7 500	11 000	20	HK 2512
	32	16	15 100	24 000	2 850	7 500	11 000	27	HK 2516
	32	16	10 500	15 300	1 760	7 000	-	27	HK 2516.2RS
	32	18	15 100	24 000	2 850	7 000	-	29	HK 2518 RS
	32	18	15 100	24 000	2 850	7 000	-	34	BK 2518 RS
	32	20	19 000	32 500	4 000	7 500	11 000	33	HK 2520
	32	20	15 100	24 000	2 850	7 000	-	31	HK 2520.2RS
	32	20	19 000	32 500	4 000	7 500	11 000	38	BK 2520
	32	24	19 000	32 500	4 000	7 000	-	40	HK 2524.2RS
	32	26	24 200	45 000	5 500	7 500	11 000	44	HK 2526

¹⁾ Double row

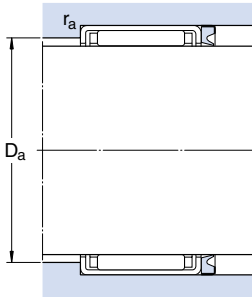

Dimensions			Abutment and fillet dimensions		Appropriate inner ring ¹⁾ Designation	seal ¹⁾ Designation
F_w	C_1	$r_{1,2}$ min	D_a max	r_a max		
mm			mm		-	
18	-	0,8	19	0,8	IR 15×18×16,5	G/SD 18×24×3
	9,3	0,8	19	0,8	IR 15×18×16,5	G/SD 18×24×3
	-	0,8	19	0,8	LR/IR 15×18×16,5	-
	-	0,8	19	0,8	IR 15×18×16,5	G/SD 18×24×3
	13,3	0,8	19	0,8	LR/IR 15×18×16,5	-
						G/SD 18×24×3
20	-	0,8	20,8	0,8	IR 15×20×12 IS1	G/SD 20×26×4
	-	0,8	20,8	0,8	IR 15×20×13	G/SD 20×26×4
	-	0,8	20,8	0,8	IR 17×20×16,5	G/SD 20×26×4
	-	0,8	21	0,8	LR/IR 17×20×16,5	-
	13,3	0,8	20,8	0,8	IR 17×20×16,5	G/SD 20×26×4
	-	0,8	21	0,8	LR/IR 17×20×20,5	-
	15,3	0,8	21	0,8	LR 17×20×16,5	-
	-	0,8	20,8	0,8	IR 17×20×20,5	G/SD 20×26×4
	-	0,8	21	0,8	LR/IR 17×20×20,5	-
	17,3	0,8	20,8	0,8	LR 17×20×20,5	G/SD 20×26×4
-	0,8	20,8	0,8	IR 17×20×30,5	G/SD 26×34×4	
22	-	0,8	23	0,8	IR 17×22×13	G/SD 22×28×4
	-	0,8	23	0,8	IR 17×22×13	G/SD 22×28×4
	9,3	0,8	23	0,8	IR 17×22×13	G/SD 22×28×4
	-	0,8	23	0,8	IR 17×22×16	-
	-	0,8	23	0,8	IR 17×22×16	G/SD 22×28×4
	-	0,8	23	0,8	IR 17×22×23	-
	13,3	0,8	23	0,8	IR 17×22×16	G/SD 22×28×4
	-	0,8	23	0,8	IR 17×22×23	-
	-	0,8	23	0,8	IR 17×22×23	G/SD 22×28×4
	-	0,8	23	0,8	IR 17×22×23	-
25	-	0,8	27	0,8	-	G 25×32×4
	-	0,8	27	0,8	IR 20×25×17	G 25×32×4
	-	0,8	27	0,8	LR 20×25×16,5	-
	-	0,8	27	0,8	LR/IR 20×25×20,5	-
	15,3	0,8	27	0,8	LR 20×25×16,5	-
	-	0,8	27	0,8	IR 20×25×20,5	G 25×32×4
	-	0,8	27	0,8	LR/IR 20×25×20,5	-
	17,3	0,8	27	0,8	IR 20×25×20,5	G 25×32×4
	-	0,8	27	0,8	LR 20×25×26,5	-
	-	0,8	27	0,8	IR 20×25×26,5	G 25×32×4

¹⁾ Details of appropriate inner rings and seals will be found in the sections "Inner rings" (→ page 204) and "Seals" (→ page 214)



Drawn cup needle roller bearings

F_w 25 – 40 mm

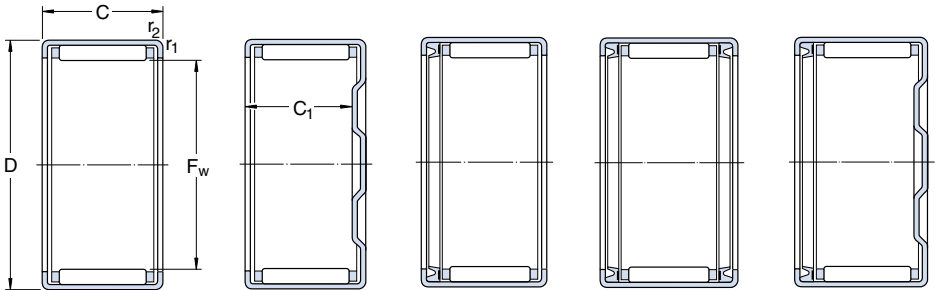

With open ends
Series HK

With closed end
Series BK

With open ends
and one seal
Series HK .. RS

With open ends
and two seals
Series HK .. 2RS

With closed end
and one seal
Series BK .. RS

Principal dimensions			Basic load ratings		Fatigue load limit P _u	Speed ratings		Mass	Designation
F _w	D	C	dynamic	static		Lubrication	oil		
mm			N		N	r/min		g	-
25 (cont.)	32	26	24 200	45 000	5 500	7 500	11 000	48	BK 2526
	32	30	24 200	45 000	5 500	7 000	-	47	HK 2530.2RS
	32	38	33 000	65 500	8 000	7 500	11 000	64	HK 2538 ¹⁾
	32	38	33 000	65 500	8 000	7 500	11 000	68	BK 2538 ¹⁾
28	35	16	15 700	26 500	3 150	6 700	9 500	29	HK 2816
	35	20	20 100	36 500	4 400	6 700	9 500	36	HK 2820
	35	20	15 700	26 500	3 150	6 300	-	34	HK 2820.2RS
30	37	12	11 700	18 300	2 120	6 300	9 000	23	HK 3012
	37	12	11 700	18 300	2 120	6 300	9 000	28	BK 3012
	37	16	16 500	29 000	3 400	6 300	9 000	31	HK 3016
	37	16	11 700	18 300	2 120	6 000	-	31	HK 3016.2RS
	37	16	16 500	29 000	3 400	6 300	9 000	38	BK 3016
	37	18	16 500	29 000	3 400	6 000	-	37	HK 3018 RS
	37	20	20 900	40 000	4 750	6 300	9 000	39	HK 3020
	37	20	16 500	29 000	3 400	6 000	-	36	HK 3020.2RS
	37	20	20 900	40 000	4 750	6 300	9 000	47	BK 3020
	37	24	20 900	40 000	4 750	6 000	-	44	HK 3024.2RS
	37	26	27 000	54 000	6 550	6 300	9 000	51	HK 3026
	37	26	27 000	54 000	6 550	6 300	9 000	58	BK 3026
37	38	35 800	80 000	9 500	6 300	9 000	76	HK 3038 ¹⁾	
37	38	35 800	80 000	9 500	6 300	9 000	84	BK 3038 ¹⁾	
35	42	12	12 500	21 600	2 450	5 600	8 000	27	HK 3512
	42	16	17 900	34 000	4 000	5 600	8 000	36	HK 3516
	42	16	12 500	21 600	2 450	5 300	-	32	HK 3516.2RS
	42	18	17 900	34 000	4 000	5 300	-	39	HK 3518 RS
	42	20	22 900	46 500	5 600	5 600	8 000	44	HK 3520
	42	20	17 900	34 000	4 000	5 300	-	41	HK 3520.2RS
	42	20	22 900	46 500	5 600	5 600	8 000	53	BK 3520
40	47	12	13 400	24 500	2 800	5 000	7 000	30	HK 4012
	47	16	19 000	39 000	4 550	5 000	7 000	39	HK 4016
	47	16	13 400	24 500	2 800	4 500	-	37	HK 4016.2RS
	47	18	19 000	39 000	4 550	4 500	-	45	HK 4018 RS
	47	20	24 200	53 000	6 400	5 000	7 000	54	HK 4020
	47	20	19 000	39 000	4 550	4 500	-	48	HK 4020.2RS
	47	20	24 200	53 000	6 400	5 000	7 000	62	BK 4020

¹⁾ Double row

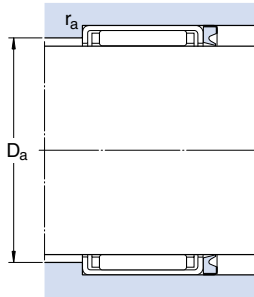

Dimensions			Abutment and fillet dimensions		Appropriate inner ring ¹⁾ Designation	seal ¹⁾ Designation
F_w	C_1	$r_{1,2}$ min	D_a max	r_a max		
mm			mm		-	
25 (cont.)	23,3	0,8	27	0,8	IR 20×25×26.5	G 25×32×4
	-	0,8	27	0,8	IR 20×25×30	-
	-	0,8	27	0,8	IR 20×25×38.5	G 25×32×4
	35,3	0,8	27	0,8	IR 20×25×38.5	G 25×32×4
28	-	0,8	30	0,8	IR 22×28×17	G/SD 28×35×4
	-	0,8	30	0,8	IR 22×28×20.5	G/SD 28×35×4
	-	0,8	30	0,8	LR/IR 22×28×20.5	-
30	-	0,8	32	0,8	-	G/SD 30×37×4
	9,3	0,8	32	0,8	-	G/SD 30×37×4
	-	0,8	32	0,8	IR 25×30×17	G/SD 30×37×4
	-	0,8	32	0,8	LR 25×30×16.5	-
	13,3	0,8	32	0,8	IR 25×30×17	G/SD 30×37×4
	-	0,8	32	0,8	LR/IR 25×30×20.5	-
	-	0,8	32	0,8	IR 25×30×20.5	G/SD 30×37×4
	-	0,8	32	0,8	LR/IR 25×30×20.5	-
	17,3	0,8	32	0,8	IR 25×30×20.5	G/SD 30×37×4
	-	0,8	32	0,8	LR/IR 25×30×26.5	-
	-	0,8	32	0,8	IR 25×30×26.5	G/SD 30×37×4
	23,3	0,8	32	0,8	IR 25×30×26.5	G/SD 30×37×4
-	0,8	32	0,8	IR 25×30×38.5	G/SD 30×37×4	
35,3	0,8	32	0,8	IR 25×30×38.5	G/SD 30×37×4	
35	-	0,8	37	0,8	-	G/SD 35×42×4
	-	0,8	37	0,8	IR 30×35×17	G/SD 35×42×4
	-	0,8	37	0,8	LR 30×35×16.5	-
	-	0,8	37	0,8	LR/IR 30×35×20.5	-
	-	0,8	37	0,8	IR 30×35×20.5	G/SD 35×42×4
	-	0,8	37	0,8	LR/IR 30×35×20.5	-
	-	0,8	37	0,8	IR 30×35×20.5	G/SD 35×42×4
	17,3	0,8	37	0,8	IR 30×35×20.5	G/SD 35×42×4
40	-	0,8	42	0,8	-	-
	-	0,8	42	0,8	IR 35×40×17	G/SD 40×47×4
	-	0,8	42	0,8	LR 35×40×16.5	-
	-	0,8	42	0,8	LR/IR 35×40×20.5	-
	-	0,8	42	0,8	IR 35×40×20.5	G/SD 40×47×4
	-	0,8	42	0,8	LR/IR 35×40×20.5	-
	-	0,8	42	0,8	IR 35×40×20.5	G/SD 40×47×4
	17,3	0,8	42	0,8	IR 35×40×20.5	G/SD 40×47×4

¹⁾ Details of appropriate inner rings and seals will be found in the sections "Inner rings" (→ page 204) and "Seals" (→ page 214)



Drawn cup needle roller bearings

F_w 45 – 60 mm

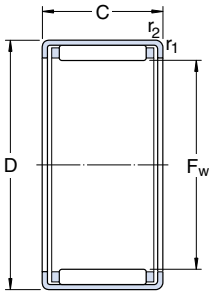

With open ends
Series HK

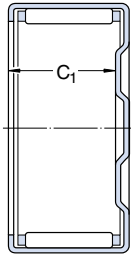

With closed end
Series BK

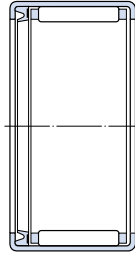

With open ends
and one seal
Series HK .. RS

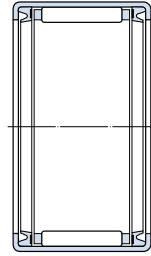

With open ends
and two seals
Series HK .. 2RS

Principal dimensions			Basic load ratings		Fatigue load limit P _u	Speed ratings		Mass	Designation
F _w	D	C	dynamic	static		Lubrication	oil		
mm			N	C ₀	N	grease		g	-
45	52	12	14 200	27 500	3 200	4 500	6 300	33	HK 4512
	52	16	20 500	43 000	5 100	4 500	6 300	46	HK 4516
	52	18	20 500	43 000	5 100	4 300	-	50	HK 4518 RS
	52	20	26 000	60 000	7 200	4 500	6 300	56	HK 4520
	52	20	20 500	43 000	5 100	4 300	-	54	HK 4520.2RS
	52	20	26 000	60 000	7 200	4 500	6 300	72	BK 4520
50	58	20	29 200	63 000	7 800	4 000	5 600	70	HK 5020
	58	22	29 200	63 000	7 800	3 800	-	76	HK 5022 RS
	58	24	29 200	63 000	7 800	3 800	-	81	HK 5024.2RS
	58	25	36 900	85 000	10 600	4 000	5 600	90	HK 5025
55	63	20	30 300	67 000	8 300	3 600	5 000	74	HK 5520
	63	28	41 800	104 000	12 900	3 600	5 000	11	HK 5528
60	68	12	17 600	32 000	3 800	3 400	4 800	49	HK 6012
	68	20	31 900	75 000	9 300	3 400	4 800	81	HK 6020
	68	32	51 200	137 000	17 000	3 400	4 800	140	HK 6032

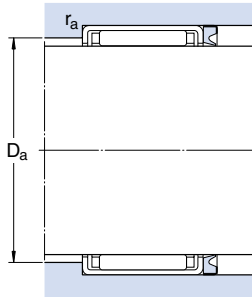

Dimensions			Abutment and fillet dimensions		Appropriate inner ring ¹⁾ Designation	seal ¹⁾ Designation
F _w	C ₁	r _{1,2} min	D _a max	r _a max		
mm			mm		-	
45	-	0,8	47	0,8	-	G/SD 45×52×4
	-	0,8	47	0,8	IR 40×45×17	G/SD 45×52×4
	-	0,8	47	0,8	LR/IR 40×45×20.5	-
	-	0,8	47	0,8	IR 40×45×20.5	G/SD 45×52×4
	-	0,8	47	0,8	LR/IR 40×45×20.5	-
	17,3	0,8	47	0,8	IR 40×45×20.5	G/SD 45×52×4
50	-	0,8	53	0,8	LR 45×50×20.5	G/SD 50×58×4
	-	0,8	53	0,8	LR/IR 45×50×25.5	-
	-	0,8	53	0,8	LR/IR 45×50×25.5	-
	-	0,8	53	0,8	LR 45×50×25.5	G/SD 50×58×4
55	-	0,8	58	0,8	LR 50×55×20.5	-
	-	0,8	58	0,8	-	-
60	-	0,8	63	0,8	-	-
	-	0,8	63	0,8	-	-
	-	0,8	63	0,8	-	-



¹⁾ Details of appropriate inner rings and seals will be found in the sections “Inner rings” (→ page 204) and “Seals” (→ page 214)



Needle roller bearings

Product tables

Needle roller bearings with flanges, without inner ring	page 74
Needle roller bearings with flanges, with inner ring	page 88
Needle roller bearings without flanges, without inner ring	page 100
Needle roller bearings without flanges, with inner ring	page 104

SKF needle roller bearings with rings of carbon chromium (bearing) steel have low sectional height and very high load carrying capacity for their size. They may be used with or without inner ring, depending on the application.

Needle roller bearings without inner ring (→ **fig 1**) are an excellent choice for bearing arrangements where the shaft can be hardened and ground. As no inner ring is needed, the shaft used will be relatively stronger and stiffer. The axial displacement of the shaft relative to the housing is only limited by the width of the raceway on the shaft. By machining the shaft raceways to appropriate dimensional and form accuracies it is possible to

produce bearing arrangements with heightened running accuracy.

Needle roller bearings with inner ring (→ **fig 2**) are used for arrangements where it is not possible, or not economic, to harden and grind the shaft. Bearings with inner ring only permit axial displacement of the shaft relative to the housing within certain limits. If this is insufficient it is possible to use an extended inner ring instead of the standard inner ring. Details will be found in the section “Inner rings” (→ **page 204**).

3

Fig 1

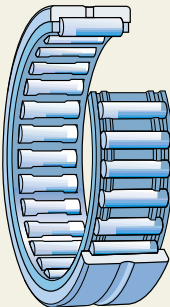
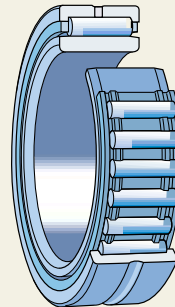

Fig 2



Needle roller bearings

SKF needle roller bearings are produced in several designs and many sizes. The majority of these are bearings with inserted or integral internal outer ring flanges (→ **fig 3**), some of which are also available in sealed versions (→ **fig 5**). Also included in the range are bearings without outer ring flanges (→ **fig 4**).

Fig 3

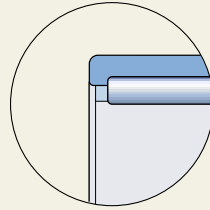
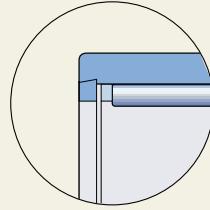

Fig 4

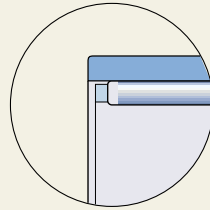
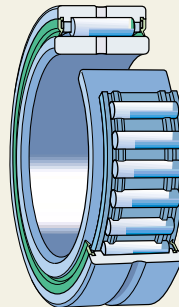

Fig 5



Needle roller bearings with flanges

SKF needle roller bearings with flanges in the outer ring and outside diameters up to and including 17 mm are produced with inserted closure rings, are without lubrication hole and do not have an annular groove (→ **fig 6**). The larger bearings have integral flanges, an annular groove and, depending on size, one or more lubrication holes in the outer ring (→ **fig 7**). The needle roller bearings with flanges are generally designed as single row bearings. The exceptions are bearings of series RNA 69 and NA 69 with an outside diameter of 52 mm and above. These have two needle roller and cage assemblies which are guided between integral flanges in the outer ring (→ **fig 8**). The outer ring with needle roller and cage assembly (assemblies) of all bearings forms a non-separable unit.

Sealed bearings

Single row bearings of series RNA 49 and NA 49 are also available with a rubbing seal at one side (→ **fig 9**) or at both sides (→ **fig 10**). The seals are made of nitrile rubber (NBR) and protect the bearings efficiently against the entry of contaminants. All sealed bearings are supplied as standard filled with a high-quality lithium base grease of consistency 2 to the NLGI Scale which has good rust inhibiting properties. The operating temperature range for the grease is from -30 to $+120$ °C.

The inner rings of the sealed bearings are 1 mm wider than the outer rings. This is to ensure that the efficiency of the seals is maintained even when small axial displacements of the shaft relative to the housing occur. The inner rings are also provided with

Fig 6

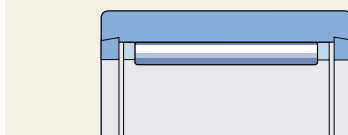

Fig 7

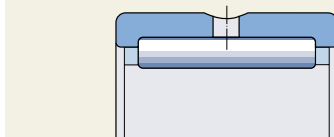

Fig 8

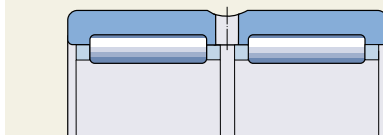

Fig 10

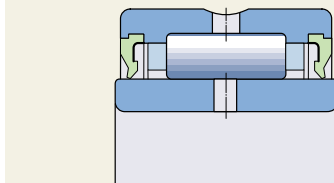

Fig 9

a lubrication hole so that the bearings may be relubricated either via the outer ring or via the inner ring, depending on the application.

Needle roller bearings

Needle roller bearings without flanges

The needle roller bearings without flanges are separable, i.e. the outer ring, the needle roller and cage assembly and the inner ring can all be mounted separately. In many applications, this considerably facilitates mounting. The needle roller and cage assembly can either be mounted together with the outer ring or with the shaft or inner ring, or it may be inserted between the outer ring and shaft or inner ring as the final step. However, the needle roller and cage assembly of any one bearing must be kept together as supplied; they are not interchangeable with those of other bearings.

SKF bearings without flanges are available as single row (→ **fig 11**) or double row bearings (→ **fig 12**). The double row bearings have two needle roller and cage assemblies arranged adjacent to each other. They have an annular groove and lubrication hole in the outer ring to ensure efficient lubrication.

The cage of needle roller bearings without flanges must be axially guided by fine turned and burr-free surfaces on adjacent machine components. Recommended dimensions for these surface are given in the product tables.

Dimensions

The boundary dimensions of needle roller bearings of series RNA 48, RNA 49, NA 48 and NA 49 conform to ISO 1206-1982 and those of series NA 69 to ISO 15:1998. The dimensions of the other needle roller bearings listed in the product tables are not standardised but have found general acceptance in industry.

Fig 11

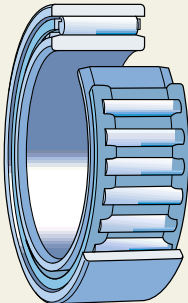
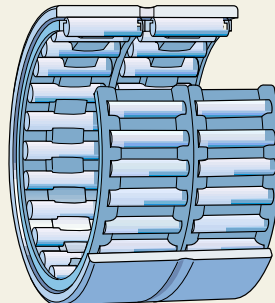

Fig 12



Tolerances

SKF needle roller bearings are produced to Normal tolerances in accordance with ISO 492:1994 as standard.

On request, bearings with higher accuracy to tolerance P6 or P5 specifications can be supplied. For bearing arrangements with heightened accuracy, it is also possible to order inner rings with a preground raceway which is then finish ground after mounting.

The inside diameter F_w of the needle roller and cage assembly when the rollers are in contact with the outer ring raceway lies within the limits of tolerance F6 before the bearings are mounted.

To order, bearings without inner ring can be supplied with reduced inside diameter tolerances. Such bearings are identified by the designation suffix H followed by a figure combination which gives the actual minimum and maximum values in μm for the deviation from the nominal inside diameter F_w , e.g. +20+24.

Values of the actual tolerances specified for the classes Normal, P6 and P5 will be found in **Tables 2 to 4** on **pages 17 to 19**.

Internal clearance

SKF needle roller bearings with inner ring are supplied with Normal radial internal clearance as standard (→ **Table 6**, **page 21**). The clearance values correspond to ISO 5753:1991.

For needle roller bearings without inner ring, a suitable internal clearance is achieved by selecting the appropriate tolerance for the raceway diameter. Recommended values will be found in **Table 1**. The recommendations apply providing the housing bore is machined to a tolerance not tighter than K7.

Misalignment

The modified line contact between the raceways and the rollers serves to prevent damaging edge stresses from occurring and also allows the single row needle roller bearings to accommodate very minor angular misalignments of the shaft relative to the

Table 1

Shaft tolerances for needle roller bearings without inner ring					
Nominal inside diameter F_w		Shaft tolerances for shaft raceways to give operational clearance			
over	incl.	less than normal	normal	greater than normal	
mm					
–					
–	65	k5	h5	g6	
65	80	k5	h5	f6	
80	160	k5	g5	f6	
160	180	k5	g5	e6	
180	200	j5	g5	e6	
200	250	j5	f6	e6	
250	315	h5	f6	e6	
315	400	g5	f6	d6	

Needle roller bearings

housing.

Cages

SKF needle roller bearings are fitted with a steel (→ **fig 13**) or sheet steel cage (→ **fig 14**) as standard except for bearings identified by the designation suffix TN. These have an injection moulded glass fibre reinforced polyamide 6,6 cage (→ **fig 15**).

NB.

Needle roller bearings with polyamide 6,6 cages can be used at temperatures up to +120 °C. With the exception of a few synthetic oils and greases with a synthetic base oil, and lubricants containing a high proportion of EP additives when used at high temperatures, the lubricants generally used for rolling bearings do not have a detrimental effect on cage properties.

For further information regarding the temperature resistance and use of cages, please refer to the section “Cages” (→ **page 22**).

For bearing arrangements which are to be operated at continuously high temperatures or under arduous conditions, it is recommended that bearings incorporating steel or sheet steel cages be used.

Raceways on the shaft

If the load carrying capacity of bearings without inner ring is to be fully utilised, the raceways on the shaft should be produced to the same quality as that normally used for bearing inner ring raceways. Details of suitable materials, surface finish and hardness will be found in the section “Raceways on shafts

Fig 13

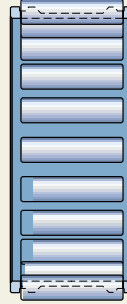
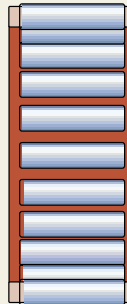

Fig 14



Fig 15



and in housings" (→ page 28).

Minimum load

In order to guarantee satisfactory operation, needle roller bearings, like all ball and roller bearings, must always be subjected to a given minimum load, particularly if they are to operate at high speeds or are subjected to high accelerations or rapid changes in the direction of load. Under such conditions the inertia forces of the needle rollers and cage, and the friction in the lubricant, can have a detrimental influence on the rolling conditions in the bearing arrangement and may cause damaging sliding movements to occur between the rollers and raceways.

The requisite minimum load to be applied to needle roller bearings can be estimated using

$$F_{rm} = 0,02 C$$

where

F_{rm} = minimum radial load, N

C = basic dynamic load rating, N

When starting up at low temperatures or when the lubricant is highly viscous, even greater loads may be required. The weights of the components supported by the bearing, together with the external forces, generally exceed the requisite minimum load. If this is not the case, the needle roller bearing must be subjected to an additional radial load.

Equivalent dynamic bearing load

Needle roller bearings can only take radial loads, therefore

$$P = F_r$$

Equivalent static bearing load

Needle roller bearings can only take radial loads, therefore

$$P_0 = F_r$$

Supplementary designations

The designation suffixes used to identify certain features of SKF needle roller bearings are explained in the following.

- C3** Radial internal clearance greater than Normal
- C4** Radial internal clearance greater than C3
- H** Reduced tolerance for the inside diameter of the roller and cage assembly. The figures following the letter H indicate the tolerance limits in μm
- IS1** One lubrication hole in the inner ring
- P5** Dimensional and running accuracy to ISO tolerance class 5 specifications (better than P6)
- P6** Dimensional and running accuracy to ISO tolerance class 6 specifications (better than Normal)
- RS** Rubbing seal at one side of bearing
- 2RS** Rubbing seals at both sides of bearing
- TN** Injection moulded glass fibre reinforced polyamide 6,6 cage
- VGS** Preground raceway on inner ring

Needle roller bearings with flanges, without inner ring

F_w 5 – 17 mm

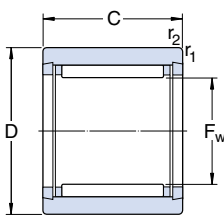

Series NK
(F_w ≤ 10 mm)

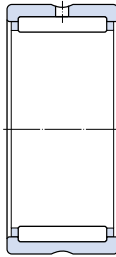

Series NK
(F_w ≥ 12 mm)
Series RNA



Series RNA 49 RS

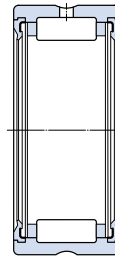

Series RNA 49.2RS

Principal dimensions			Basic load ratings		Fatigue load limit P _u	Speed ratings		Mass	Designation
F _w	D	C	dynamic	static		Lubrication grease	oil		
mm			N		N	r/min		kg	–
5	10	10	2 290	2 000	212	36 000	50 000	0,0031	NK 5/10 TN
	10	12	2 920	2 700	290	36 000	50 000	0,0037	NK 5/12 TN
6	12	10	2 550	2 360	250	32 000	45 000	0,0047	NK 6/10 TN
	12	12	3 300	3 200	345	32 000	45 000	0,0057	NK 6/12 TN
7	14	10	2 810	2 750	290	30 000	43 000	0,0069	NK 7/10 TN
	14	12	3 580	3 750	415	30 000	43 000	0,0082	NK 7/12 TN
8	15	12	3 800	4 250	465	28 000	40 000	0,0087	NK 8/12 TN
	15	16	5 010	5 850	670	28 000	40 000	0,012	NK 8/16 TN
9	16	12	4 400	5 200	570	24 000	36 000	0,010	NK 9/12 TN
	16	16	5 720	7 200	815	24 000	36 000	0,013	NK 9/16 TN
10	17	12	4 400	5 400	620	22 000	34 000	0,010	NK 10/12 TN
	17	16	5 940	8 000	900	22 000	34 000	0,013	NK 10/16 TN
12	19	12	6 710	8 150	965	19 000	30 000	0,012	NK 12/12
	19	16	9 130	12 000	1 460	19 000	30 000	0,016	NK 12/16
14	22	13	8 800	10 400	1 250	17 000	26 000	0,017	RNA 4900
	22	13	7 370	8 150	950	13 000	13 000	0,016	RNA 4900 RS
	22	13	7 370	8 150	950	13 000	–	0,016	RNA 4900.2RS
	22	16	10 200	12 500	1 530	17 000	26 000	0,021	NK 14/16
	22	20	12 800	16 600	2 080	17 000	26 000	0,026	NK 14/20
15	23	16	11 000	14 000	1 700	16 000	24 000	0,022	NK 15/16
	23	20	13 800	18 300	2 280	16 000	24 000	0,027	NK 15/20
16	24	13	9 900	12 200	1 460	16 000	24 000	0,017	RNA 4901
	24	13	8 090	9 650	1 140	12 000	12 000	0,018	RNA 4901 RS
	24	13	8 090	9 650	1 140	12 000	–	0,018	RNA 4901.2RS
	24	16	11 700	15 300	1 860	16 000	24 000	0,022	NK 16/16
	24	20	14 500	20 000	2 500	16 000	24 000	0,028	NK 16/20
	24	22	16 100	23 200	2 900	16 000	24 000	0,031	RNA 6901
17	25	16	12 100	16 600	2 000	15 000	22 000	0,024	NK 17/16
	25	20	15 100	22 000	2 750	15 000	22 000	0,030	NK 17/20

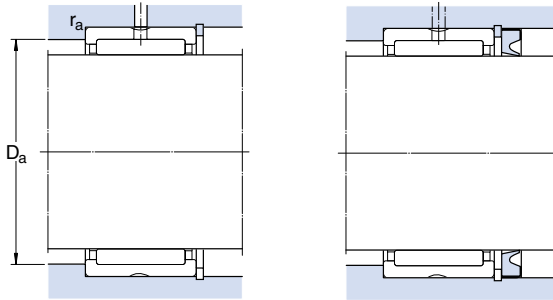

Dimensions **Abutment and fillet dimensions** **Appropriate seal¹⁾**
Designation

F_w	$r_{1,2}$ min	D_a max	r_a max	
mm		mm		–
5	0,15 0,15	8,8 8,8	0,1 0,1	G 5 × 10 × 2 G 5 × 10 × 2
6	0,15 0,15	10,8 10,8	0,1 0,1	G 6 × 12 × 2 G 6 × 12 × 2
7	0,3 0,3	12 12	0,3 0,3	G 7 × 14 × 2 G 7 × 14 × 2
8	0,3 0,3	13 13	0,3 0,3	G/SD 8 × 15 × 3 G/SD 8 × 15 × 3
9	0,3 0,3	14 14	0,3 0,3	G 9 × 16 × 3 G 9 × 16 × 3
10	0,3 0,3	15 15	0,3 0,3	G/SD 10 × 17 × 3 G/SD 10 × 17 × 3
12	0,3 0,3	17 17	0,3 0,3	G/SD 12 × 19 × 3 G/SD 12 × 19 × 3
14	0,3 0,3 0,3 0,3 0,3	20 20 20 20 20	0,3 0,3 0,3 0,3 0,3	G/SD 14 × 22 × 3 – G/SD 14 × 22 × 3 G/SD 14 × 22 × 3
15	0,3 0,3	21 21	0,3 0,3	G/SD 15 × 23 × 3 G/SD 15 × 23 × 3
16	0,3 0,3 0,3 0,3 0,3 0,3	22 22 22 22 22 22	0,3 0,3 0,3 0,3 0,3 0,3	G/SD 16 × 24 × 3 – – G/SD 16 × 24 × 3 G/SD 16 × 24 × 3 G/SD 16 × 24 × 3
17	0,3 0,3	23 23	0,3 0,3	G/SD 17 × 25 × 3 G/SD 17 × 25 × 3

¹⁾ Details of the G and SD seals will be found in the section “Seals” (→ page 214)

Needle roller bearings with flanges, without inner ring

F_w 18 – 26 mm

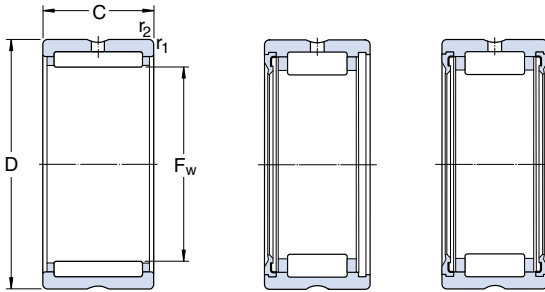

Series NK
Series RNA 49
Series RNA 69

Series RNA 49 RS

Series RNA 49.2RS

Principal dimensions			Basic load ratings		Fatigue load limit P _u	Speed ratings		Mass kg	Designation
F _w	D	C	C	C ₀		Lubrication grease	oil		
mm			N		N	r/min			-
18	26	16	12 800	17 600	2 160	15 000	22 000	0,025	NK 18/16
	26	20	16 100	23 600	3 000	15 000	22 000	0,031	NK 18/20
19	27	16	13 400	19 000	2 320	14 000	20 000	0,026	NK 19/16
	27	20	16 500	25 500	3 200	14 000	20 000	0,032	NK 19/20
20	28	13	11 200	15 300	1 830	13 000	19 000	0,022	RNA 4902
	28	13	9 130	12 000	1 400	9 500	9 500	0,022	RNA 4902 RS
	28	13	9 130	12 000	1 400	9 500	-	0,022	RNA 4902.2RS
	28	16	13 200	19 300	2 360	13 000	19 000	0,027	NK 20/16
	28	20	16 500	25 500	3 200	13 000	19 000	0,034	NK 20/20
	28	23	17 200	27 000	3 400	13 000	19 000	0,040	RNA 6902
21	29	16	13 800	20 400	2 500	13 000	19 000	0,028	NK 21/16
	29	20	17 200	27 000	3 450	13 000	19 000	0,035	NK 21/20
22	30	13	11 400	16 300	1 960	12 000	18 000	0,022	RNA 4903
	30	13	9 520	12 900	1 500	9 000	9 000	0,023	RNA 4903 RS
	30	13	9 520	12 900	1 500	9 000	-	0,023	RNA 4903.2RS
	30	16	14 200	21 600	2 650	12 000	18 000	0,030	NK 22/16
	30	20	17 900	29 000	3 650	12 000	18 000	0,037	NK 22/20
	30	23	18 700	30 500	3 900	12 000	18 000	0,042	RNA 6903
24	32	16	15 400	24 500	3 000	10 000	16 000	0,032	NK 24/16
	32	20	19 000	32 500	4 050	10 000	16 000	0,040	NK 24/20
	37	20	26 000	33 500	4 250	9 500	15 000	0,066	NKS 24
25	33	16	15 100	24 500	3 000	10 000	16 000	0,033	NK 25/16
	33	20	19 000	32 500	4 150	10 000	16 000	0,042	NK 25/20
	37	17	21 600	28 000	3 550	9 500	15 000	0,052	RNA 4904
	37	17	19 400	22 400	2 750	7 500	7 500	0,056	RNA 4904 RS
	37	17	19 400	22 400	2 750	7 500	-	0,056	RNA 4904.2RS
	37	30	35 200	53 000	6 950	9 500	15 000	0,10	RNA 6904
	38	20	27 500	36 000	4 550	9 500	15 000	0,068	NKS 25
26	34	16	15 700	26 000	3 200	9 500	15 000	0,034	NK 26/16
	34	20	19 400	34 500	4 300	9 500	15 000	0,042	NK 26/20

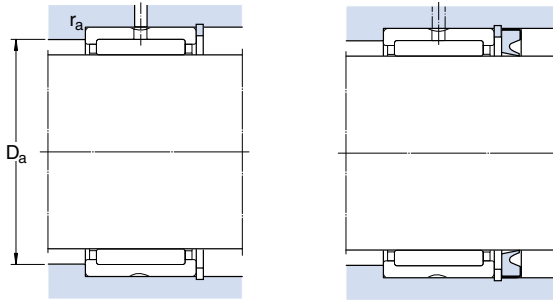

Dimensions		Abutment and fillet dimensions		Appropriate seal ¹⁾
F_w	$r_{1,2}$ min	D_a max	r_a max	Designation

F_w	$r_{1,2}$ min	D_a max	r_a max	Designation
mm		mm		–
18	0,3	24	0,3	G/SD 18 × 26 × 4
	0,3	24	0,3	G/SD 18 × 26 × 4
19	0,3	25	0,3	G/SD 19 × 27 × 4
	0,3	25	0,3	G/SD 19 × 27 × 4
20	0,3	26	0,3	G/SD 20 × 28 × 4
	0,3	26	0,3	–
	0,3	26	0,3	–
	0,3	26	0,3	G/SD 20 × 28 × 4
	0,3	26	0,3	G/SD 20 × 28 × 4
	0,3	26	0,3	G/SD 20 × 28 × 4
21	0,3	27	0,3	G 21 × 29 × 4
	0,3	27	0,3	G 21 × 29 × 4
22	0,3	28	0,3	G/SD 22 × 30 × 4
	0,3	28	0,3	–
	0,3	28	0,3	–
	0,3	28	0,3	G/SD 22 × 30 × 4
	0,3	28	0,3	G/SD 22 × 30 × 4
	0,3	28	0,3	G/SD 22 × 30 × 4
24	0,3	30	0,3	G/SD 24 × 32 × 4
	0,3	30	0,3	G/SD 24 × 32 × 4
	0,6	33	0,6	–
25	0,3	31	0,3	G/SD 25 × 33 × 4
	0,3	31	0,3	G/SD 25 × 33 × 4
	0,3	35	0,3	CR 25 × 37 × 7 CRW1R
	0,3	35	0,3	–
	0,3	35	0,3	–
	0,3	35	0,3	CR 25 × 37 × 7 CRW1R
	0,6	34	0,6	CR 25 × 38 × 7 CRW1R
26	0,3	32	0,3	G/SD 26 × 34 × 4
	0,3	32	0,3	G/SD 26 × 34 × 4

¹⁾ Details of the G and SD seals will be found in the section “Seals” (→ page 214). The CR seals are described in catalogue 4006 “CR seals”

Needle roller bearings with flanges, without inner ring

F_w 28 – 38 mm

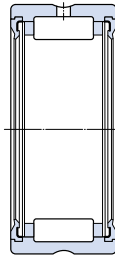
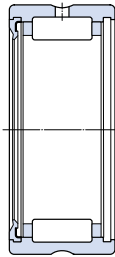
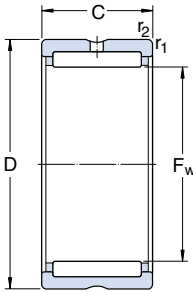

Series NK(S)
Series RNA 49
Series RNA 69

Series RNA 49 RS

Series RNA 49.2RS

Principal dimensions	Basic load ratings		Fatigue load limit P _u	Speed ratings		Mass	Designation	
	dynamic	static C ₀		Lubrication grease	oil			
F _w D C	C	C ₀	N	r/min	kg	–		
mm	N		N	r/min	kg	–		
28	37 20	22 000	36 500	4 650	9 000	14 000	0,052	NK 28/20
	37 30	31 900	60 000	7 800	9 000	14 000	0,082	NK 28/30
	39 17	23 300	32 000	4 050	9 000	14 000	0,050	RNA 49/22
	39 30	36 900	57 000	7 500	9 000	14 000	0,098	RNA 69/22
	42 20	28 600	39 000	5 000	8 500	13 000	0,084	NKS 28
29	38 20	22 000	36 500	4 650	9 000	14 000	0,054	NK 29/20
	38 30	31 900	60 000	7 800	9 000	14 000	0,084	NK 29/30
30	40 20	22 900	38 000	4 900	8 500	13 000	0,065	NK 30/20
	40 30	33 000	63 000	8 150	8 500	13 000	0,098	NK 30/30
	42 17	24 200	34 500	4 300	8 500	13 000	0,061	RNA 4905
	42 17	21 600	27 500	3 350	6 300	6 300	0,060	RNA 4905 RS
	42 17	21 600	27 500	3 350	6 300	–	0,060	RNA 4905.2RS
	42 30	38 000	62 000	8 150	8 500	13 000	0,11	RNA 6905
	45 22	31 900	43 000	5 500	8 000	12 000	0,10	NKS 30
32	42 20	23 300	40 500	5 200	8 000	12 000	0,068	NK 32/20
	42 30	34 100	65 500	8 650	8 000	12 000	0,10	NK 32/30
	45 17	25 100	36 500	4 550	8 000	12 000	0,073	RNA 49/28
	45 30	39 600	65 500	8 650	8 000	12 000	0,14	RNA 69/28
	47 22	34 100	46 500	6 000	8 000	12 000	0,11	NKS 32
35	45 20	24 600	45 000	5 700	7 500	11 000	0,074	NK 35/20
	45 30	35 800	72 000	9 500	7 500	11 000	0,11	NK 35/30
	47 17	25 500	39 000	4 900	7 500	11 000	0,069	RNA 4906
	47 17	23 300	32 000	3 900	5 600	5 600	0,069	RNA 4906 RS
	47 17	23 300	32 000	3 900	5 600	–	0,069	RNA 4906.2RS
	47 30	42 900	75 000	9 800	7 500	11 000	0,13	RNA 6906
	50 22	35 200	50 000	6 400	7 500	11 000	0,12	NKS 35
37	47 20	25 100	46 500	5 850	7 500	11 000	0,077	NK 37/20
	47 30	36 900	76 500	10 000	7 500	11 000	0,11	NK 37/30
	52 22	36 900	54 000	6 950	7 000	10 000	0,12	NKS 37
38	48 20	25 500	49 000	6 200	7 500	11 000	0,079	NK 38/20
	48 30	37 400	80 000	10 400	7 500	11 000	0,12	NK 38/30

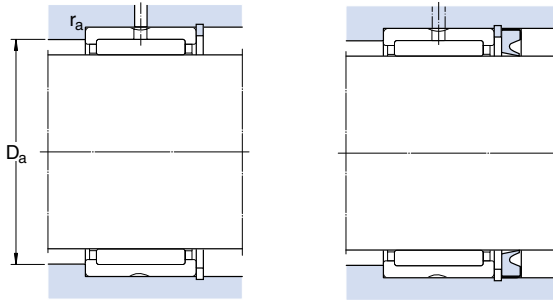

Dimensions		Abutment and fillet dimensions		Appropriate seal ¹⁾ Designation
------------	--	--------------------------------	--	---

F_w	$r_{1,2}$ min	D_a max	r_a max	
mm		mm		–
28	0,3	35	0,3	G/SD 28 × 37 × 4
	0,3	35	0,3	G/SD 28 × 37 × 4
	0,3	37	0,3	–
	0,3	37	0,3	–
	0,3	38	0,6	CR 28 × 42 × 7 CRW1R
29	0,3	36	0,3	G/SD 29 × 38 × 4
	0,3	36	0,3	G/SD 29 × 38 × 4
30	0,3	38	0,3	G/SD 30 × 40 × 4
	0,3	38	0,3	G/SD 30 × 40 × 4
	0,3	40	0,3	CR 30 × 42 × 7 CRW1R
	0,3	40	0,3	–
	0,3	40	0,3	–
	0,6	41	0,6	CR 30 × 42 × 7 CRW1R CR 30 × 45 × 8 CRW1R
32	0,3	40	0,3	G/SD 32 × 42 × 4
	0,3	40	0,3	G/SD 32 × 42 × 4
	0,3	43	0,3	G 32 × 45 × 4
	0,3	43	0,3	G 32 × 45 × 4
	0,6	43	0,6	CR 32 × 47 × 8 CRW1R
35	0,3	43	0,3	G/SD 35 × 45 × 4
	0,3	43	0,3	G/SD 35 × 45 × 4
	0,3	45	0,3	CR 35 × 47 × 7 CRW1R
	0,3	45	0,3	–
	0,3	45	0,3	–
	0,6	46	0,6	CR 35 × 47 × 7 CRW1R CR 35 × 50 × 8 CRW1R
37	0,3	45	0,3	G/SD 37 × 47 × 4
	0,3	45	0,3	G/SD 37 × 47 × 4
	0,6	48	0,6	–
38	0,3	46	0,3	G/SD 38 × 48 × 4
	0,3	46	0,3	G/SD 38 × 48 × 4

¹⁾ Details of the G and SD seals will be found in the section “Seals” (→ page 214). The CR seals are described in catalogue 4006 “CR seals”

Needle roller bearings with flanges, without inner ring

F_w 40 – 52 mm

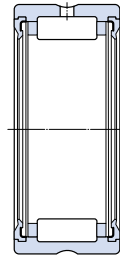
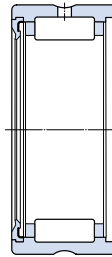
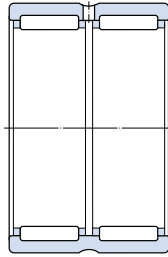
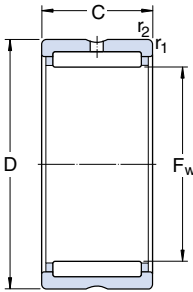

Series NK(S)
Series RNA 49

Series RNA 69

Series RNA 49 RS

Series RNA 49.2RS

Principal dimensions			Basic load ratings		Fatigue load limit P _u	Speed ratings		Mass kg	Designation
F _w	D	C	C	C ₀		Lubrication grease	oil		
mm			N		N	r/min		kg	–
40	50	20	26 400	51 000	6 400	7 000	10 000	0,083	NK 40/20
	50	30	38 000	83 000	10 800	7 000	10 000	0,13	NK 40/30
	52	20	30 800	51 000	6 550	7 000	10 000	0,089	RNA 49/32
	52	36	47 300	90 000	11 200	7 000	10 000	0,16	RNA 69/32
	55	22	38 000	57 000	7 350	6 700	9 500	0,13	NKS 40
42	52	20	27 000	53 000	6 700	6 700	9 500	0,086	NK 42/20
	52	30	39 100	86 500	11 200	6 700	9 500	0,13	NK 42/30
	55	20	31 900	54 000	6 950	6 700	9 500	0,11	RNA 4907
	55	20	27 000	43 000	5 400	4 800	4 800	0,11	RNA 4907 RS
	55	20	27 000	43 000	5 400	4 800	–	0,11	RNA 4907.2RS
55	36	48 400	93 000	11 800	6 700	9 500	0,19	RNA 6907	
43	53	20	27 500	55 000	6 950	6 700	9 500	0,086	NK 43/20
	53	30	40 200	90 000	11 600	6 700	9 500	0,13	NK 43/30
	58	22	39 100	61 000	7 800	6 300	9 000	0,14	NKS 43
45	55	20	27 500	57 000	7 200	6 300	9 000	0,092	NK 45/20
	55	30	40 200	93 000	12 000	6 300	9 000	0,14	NK 45/30
	60	22	40 200	64 000	8 300	6 000	8 500	0,15	NKS 45
47	57	20	29 200	61 000	7 650	6 000	8 500	0,095	NK 47/20
	57	30	41 800	98 000	12 900	6 000	8 500	0,14	NK 47/30
48	62	22	42 900	71 000	9 150	5 600	8 000	0,14	RNA 4908
	62	22	36 900	58 500	7 350	4 000	4 000	0,15	RNA 4908 RS
	62	22	36 900	58 500	7 350	4 000	–	0,15	RNA 4908.2RS
	62	40	67 100	125 000	16 000	5 600	8 000	0,26	RNA 6908
50	62	25	38 000	78 000	10 000	5 600	8 000	0,16	NK 50/25
	62	35	49 500	110 000	14 300	5 600	8 000	0,22	NK 50/35
	65	22	42 900	72 000	9 150	5 600	8 000	0,16	NKS 50
52	68	22	45 700	78 000	10 000	5 300	7 500	0,18	RNA 4909
	68	22	39 100	64 000	8 000	3 800	3 800	0,16	RNA 4909 RS
	68	22	39 100	64 000	8 000	3 800	–	0,16	RNA 4909.2RS
	68	40	70 400	137 000	17 300	5 300	7 500	0,34	RNA 6909

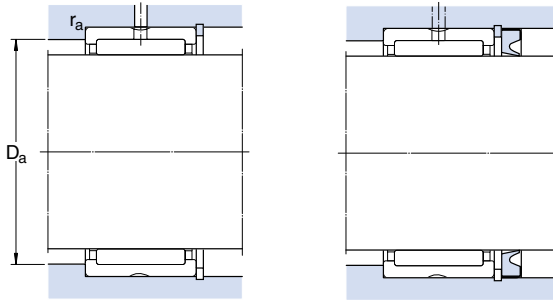

Dimensions		Abutment and fillet dimensions		Appropriate seal ¹⁾
F_w	$r_{1,2}$ min	D_a max	r_a max	Designation
mm		mm		–
40	0,3	48	0,3	G/SD 40 × 50 × 4
	0,3	48	0,3	G/SD 40 × 50 × 4
	0,6	48	0,6	G/SD 40 × 52 × 5
	0,6	48	0,6	G/SD 40 × 52 × 5
	0,6	51	0,6	CR 40 × 55 × 8 CRW1R
42	0,3	50	0,3	G/SD 42 × 52 × 4
	0,3	50	0,3	G/SD 42 × 52 × 4
	0,6	51	0,6	CR 42 × 55 × 8 CRW1R
	0,6	51	0,6	–
	0,6	51	0,6	–
	0,6	51	0,6	CR 42 × 55 × 8 CRW1R
43	0,3	51	0,3	G 43 × 53 × 4
	0,3	51	0,3	G 43 × 53 × 4
	0,6	53	0,6	–
45	0,3	53	0,3	G/SD 45 × 55 × 4
	0,3	53	0,3	G/SD 45 × 55 × 4
	0,6	56	0,6	CR 45 × 60 × 8 CRW1R
47	0,3	55	0,3	–
	0,3	55	0,3	–
48	0,6	58	0,6	CR 48 × 62 × 8 CRW1R
	0,6	58	0,6	–
	0,6	58	0,6	–
	0,6	58	0,6	CR 48 × 62 × 8 CRW1R
50	0,6	58	0,6	G/SD 50 × 62 × 4
	0,6	58	0,6	G/SD 50 × 62 × 4
	1	60	1	CR 50 × 65 × 8 CRW1R
52	0,6	64	0,6	CR 52 × 68 × 8 CRW1R
	0,6	64	0,6	–
	0,6	64	0,6	–
	0,6	64	0,6	–
	0,6	64	0,6	CR 52 × 68 × 8 CRW1R

¹⁾ Details of the G and SD seals will be found in the section “Seals” (→ page 214). The CR seals are described in catalogue 4006 “CR seals”



Needle roller bearings with flanges, without inner ring

F_w 55 – 75 mm

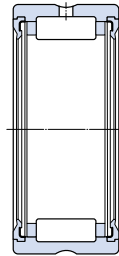
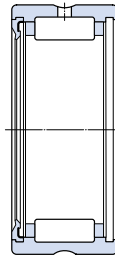
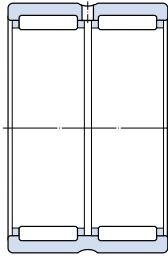
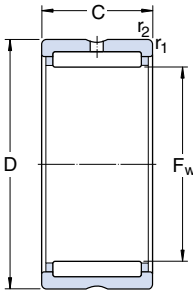

Series NK(S)
Series RNA 49

Series RNA 69

Series RNA 49 RS

Series RNA 49.2RS

Principal dimensions			Basic load ratings		Fatigue load limit P _u	Speed ratings		Mass	Designation
F _w	D	C	dynamic	static C ₀		Lubrication grease	oil		
mm			N		N	r/min		kg	–
55	68	25	40 200	88 000	11 200	5 300	7 500	0,18	NK 55/25
	68	35	52 300	122 000	16 000	5 300	7 500	0,25	NK 55/35
	72	22	44 600	78 000	10 000	5 000	7 000	0,22	NKS 55
58	72	22	47 300	85 000	11 000	5 000	7 000	0,16	RNA 4910
	72	22	40 200	69 500	8 800	3 400	3 400	0,16	RNA 4910 RS
	72	22	40 200	69 500	8 800	3 400	–	0,16	RNA 4910.2RS
	72	40	73 700	150 000	19 000	5 000	7 000	0,31	RNA 6910
60	72	25	41 800	96 500	12 200	4 800	6 700	0,19	NK 60/25
	72	35	55 000	134 000	17 600	4 800	6 700	0,26	NK 60/35
	80	28	62 700	104 000	13 700	4 500	6 300	0,34	NKS 60
63	80	25	57 200	106 000	13 700	4 500	6 300	0,26	RNA 4911
	80	45	89 700	190 000	24 000	4 500	6 300	0,47	RNA 6911
65	78	25	44 000	104 000	13 200	4 500	6 300	0,22	NK 65/25
	78	35	58 300	146 000	19 300	4 500	6 300	0,31	NK 65/35
	85	28	66 000	114 000	15 000	4 300	6 000	0,36	NKS 65
68	82	25	44 000	95 000	12 000	4 300	6 000	0,24	NK 68/25
	82	35	60 500	146 000	19 000	4 300	6 000	0,34	NK 68/35
	85	25	60 500	114 000	14 600	4 300	6 000	0,28	RNA 4912
	85	45	93 500	204 000	26 000	4 300	6 000	0,49	RNA 6912
70	85	25	44 600	98 000	12 500	4 300	6 000	0,26	NK 70/25
	85	35	61 600	150 000	19 600	4 300	6 000	0,37	NK 70/35
	90	28	68 200	120 000	15 600	4 000	5 600	0,38	NKS 70
72	90	25	61 600	120 000	15 300	4 000	5 600	0,31	RNA 4913
	90	45	95 200	212 000	27 000	4 000	5 600	0,58	RNA 6913
73	90	25	52 800	106 000	13 700	4 000	5 600	0,30	NK 73/25
	90	35	73 700	163 000	21 600	4 000	5 600	0,43	NK 73/35
75	92	25	53 900	110 000	14 000	3 800	5 300	0,32	NK 75/25
	92	35	74 800	170 000	22 000	3 800	5 300	0,45	NK 75/35
	95	28	70 400	132 000	17 000	3 800	5 300	0,40	NKS 75

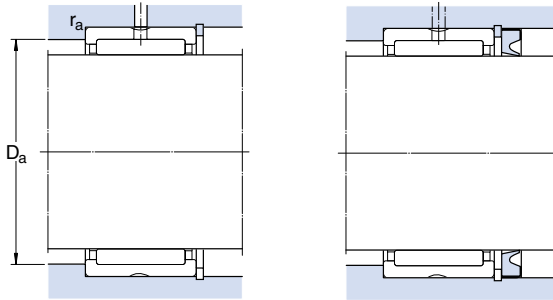

Dimensions		Abutment and fillet dimensions		Appropriate seal ¹⁾
F_w	$r_{1,2}$ min	D_a max	r_a max	Designation
mm		mm		–
55	0,6	64	0,6	–
	0,6	64	0,6	–
	1	67	1	CR 55 × 72 × 8 CRW1R
58	0,6	68	0,6	CR 58 × 72 × 8 CRW1R
	0,6	68	0,6	–
	0,6	68	0,6	–
	0,6	68	0,6	CR 58 × 72 × 8 CRW1R
60	0,6	68	0,6	–
	0,6	68	0,6	–
	1,1	73,5	1	–
63	1	75	1	CR 63 × 80 × 8 CRW1R
	1	75	1	CR 63 × 80 × 8 CRW1R
65	0,6	74	0,6	–
	0,6	74	0,6	–
	1,1	78,5	1	CR 65 × 85 × 8 CRW1R
68	0,6	78	0,6	–
	0,6	78	0,6	–
	1	80	1	CR 68 × 85 × 8 CRW1R
	1	80	1	CR 68 × 85 × 8 CRW1R
70	0,6	81	0,6	CR 70 × 85 × 8 CRW1R
	0,6	81	0,6	CR 70 × 85 × 8 CRW1R
	1,1	83,5	1	CR 70 × 95 × 10 CRW1R
72	1	85	1	CR 72 × 90 × 10 CRSH1R
	1	85	1	CR 72 × 90 × 10 CRSH1R
73	1	85	1	–
	1	85	1	–
75	1	87	1	–
	1	87	1	–
	1,1	88,5	1	CR 75 × 95 × 10 CRW1R

¹⁾ The CR seals are described in catalogue 4006 "CR seals"

Needle roller bearings with flanges, without inner ring

F_w 80 – 130 mm

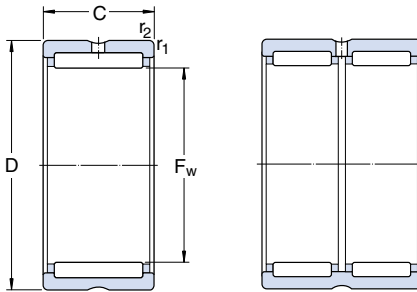

Series NK
Series RNA 48
Series RNA 49

Series RNA 69

Principal dimensions			Basic load ratings		Fatigue load limit P _u	Speed ratings		Mass	Designation
F _w	D	C	dynamic	static		Lubrication grease	oil		
mm			C	C ₀	N	r/min		kg	–
80	95	25	56 100	127 000	16 000	3 600	5 000	0,30	NK 80/25
	95	35	76 500	190 000	25 000	3 600	5 000	0,43	NK 80/35
	100	30	84 200	163 000	21 600	3 600	5 000	0,46	RNA 4914
	100	54	128 000	285 000	37 500	3 600	5 000	0,86	RNA 6914
85	105	25	69 300	132 000	17 000	3 400	4 800	0,43	NK 85/25
	105	30	84 200	170 000	22 400	3 400	4 800	0,49	RNA 4915
	105	35	96 800	200 000	27 000	3 400	4 800	0,60	NK 85/35
	105	54	130 000	290 000	38 000	3 400	4 800	0,94	RNA 6915
90	110	25	72 100	140 000	18 300	3 200	4 500	0,45	NK 90/25
	110	30	88 000	183 000	24 000	3 200	4 500	0,52	RNA 4916
	110	35	101 000	216 000	29 000	3 200	4 500	0,63	NK 90/35
	110	54	134 000	315 000	41 500	3 200	4 500	0,99	RNA 6916
95	115	26	73 700	146 000	19 000	3 000	4 300	0,49	NK 95/26
	115	36	105 000	232 000	30 500	3 000	4 300	0,68	NK 95/36
100	120	26	76 500	156 000	19 600	2 800	4 000	0,52	NK 100/26
	120	35	108 000	250 000	32 000	2 800	4 000	0,66	RNA 4917
	120	36	108 000	250 000	32 000	2 800	4 000	0,72	NK 100/36
	120	63	165 000	425 000	54 000	2 800	4 000	1,20	RNA 6917
105	125	26	78 100	166 000	20 800	2 600	3 800	0,54	NK 105/26
	125	35	112 000	265 000	33 500	2 600	3 800	0,75	RNA 4918
	125	36	112 000	265 000	33 500	2 600	3 800	0,71	NK 105/36
	125	63	172 000	450 000	57 000	2 600	3 800	1,35	RNA 6918
110	130	30	96 800	220 000	27 500	2 400	3 600	0,65	NK 110/30
	130	35	114 000	270 000	34 000	2 400	3 600	0,72	RNA 4919
	130	40	123 000	305 000	38 000	2 400	3 600	0,83	NK 110/40
	130	63	172 000	465 000	57 000	2 400	3 600	1,45	RNA 6919
115	140	40	125 000	280 000	34 500	2 200	3 400	1,15	RNA 4920
120	140	30	93 500	232 000	27 500	2 200	3 400	0,67	RNA 4822
125	150	40	130 000	300 000	36 500	2 000	3 200	1,25	RNA 4922
130	150	30	99 000	255 000	30 000	2 000	3 200	0,73	RNA 4824

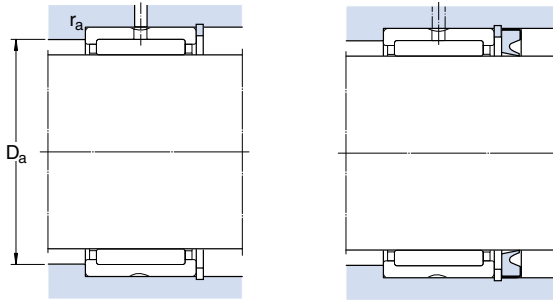

Dimensions		Abutment and fillet dimensions		Appropriate seal ¹⁾
F _w	r _{1,2} min	D _a max	r _a max	Designation
mm		mm		–
80	1	90	1	–
	1	90	1	–
	1	95	1	CR 80 × 100 × 10 CRW1R
	1	95	1	CR 80 × 100 × 10 CRW1R
85	1	100	1	CR 85 × 105 × 10 CRW1R
	1	100	1	CR 85 × 105 × 10 CRW1R
	1	100	1	CR 85 × 105 × 10 CRW1R
	1	100	1	CR 85 × 105 × 10 CRW1R
90	1	105	1	CR 90 × 110 × 12 CRW1R
	1	105	1	CR 90 × 110 × 12 CRW1R
	1	105	1	CR 90 × 110 × 12 CRW1R
	1	105	1	CR 90 × 110 × 12 CRW1R
95	1	110	1	CR 95 × 115 × 12 CRW1R
	1	110	1	CR 95 × 115 × 12 CRW1R
100	1	115	1	CR 100 × 120 × 12 CRW1R
	1,1	113,5	1	CR 100 × 120 × 12 CRW1R
	1	115	1	CR 100 × 120 × 12 CRW1R
	1,1	113,5	1	CR 100 × 120 × 12 CRW1R
105	1	120	1	–
	1,1	118,5	1	–
	1	120	1	–
	1,1	118,5	1	–
110	1,1	123,5	1	CR 110 × 130 × 12 CRW1R
	1,1	123,5	1	CR 110 × 130 × 12 CRW1R
	1,1	123,5	1	CR 110 × 130 × 12 CRW1R
	1,1	123,5	1	CR 110 × 130 × 12 CRW1R
115	1,1	133,5	1	CR 115 × 140 × 12 CRW1R
120	1	135	1	CR 120 × 140 × 13 HMS4R
125	1,1	143,5	1	CR 125 × 150 × 12 CRW1R
130	1	145	1	–

¹⁾ The CR seals are described in catalogue 4006 "CR seals"

Needle roller bearings with flanges, without inner ring

F_w 135 – 415 mm

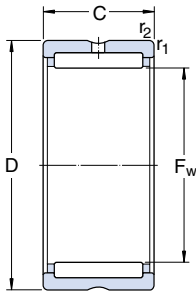

Principal dimensions			Basic load ratings		Fatigue load limit P _u	Speed ratings		Mass	Designation
F _w	D	C	dynamic	static		Lubrication	oil		
mm			C	C ₀	N	r/min	grease	kg	–
135	165	45	176 000	405 000	47 500	1 900	3 000	1,85	RNA 4924
145	165	35	119 000	325 000	37 500	1 800	2 800	0,99	RNA 4826
150	180	50	198 000	480 000	55 000	1 700	2 600	2,20	RNA 4926
155	175	35	121 000	345 000	38 000	1 700	2 600	1,05	RNA 4828
160	190	50	205 000	510 000	58 500	1 600	2 400	2,35	RNA 4928
165	190	40	147 000	415 000	46 500	1 600	2 400	1,60	RNA 4830
175	200	40	157 000	450 000	50 000	1 500	2 200	1,70	RNA 4832
185	215	45	179 000	520 000	57 000	1 500	2 200	2,55	RNA 4834
195	225	45	190 000	570 000	60 000	1 400	2 000	2,70	RNA 4836
210	240	50	220 000	710 000	73 500	1 300	1 900	3,20	RNA 4838
220	250	50	224 000	735 000	75 000	1 200	1 800	3,35	RNA 4840
240	270	50	238 000	815 000	81 500	1 100	1 700	3,60	RNA 4844
265	300	60	347 000	1 120 000	108 000	950	1 500	5,40	RNA 4848
285	320	60	358 000	1 200 000	114 000	900	1 400	5,80	RNA 4852
305	350	69	429 000	1 320 000	127 000	850	1 300	9,30	RNA 4856
330	380	80	594 000	1 800 000	170 000	750	1 100	12,5	RNA 4860
350	400	80	605 000	1 900 000	176 000	750	1 100	13,5	RNA 4864
370	420	80	616 000	1 960 000	180 000	700	1 000	14,0	RNA 4868
390	440	80	627 000	2 040 000	186 000	670	950	15,0	RNA 4872
415	480	100	968 000	3 000 000	265 000	630	900	26,0	RNA 4876

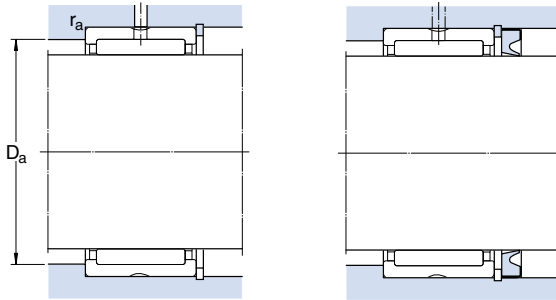

Dimensions		Abutment and fillet dimensions		Appropriate seal ¹⁾ Designation
F_w	$r_{1,2}$ min	D_a max	r_a max	
mm		mm		-
135	1,1	158,5	1	-
145	1,1	158,5	1	CR 145 × 165 × 13 CRSH1R
150	1,5	1172	1,5	CR 150 × 180 × 12 HMS4R
155	1,1	168,5	1	-
160	1,5	182	1,5	CR 160 × 190 × 15 CRW1V
165	1,1	183,5	1	-
175	1,1	193,5	1	-
185	1,1	208,5	1	-
195	1,1	218,5	1	-
210	1,5	232	1,5	-
220	1,5	242	1,5	CR 220 × 250 × 15 HMS4R
240	1,5	262	1,5	CR 240 × 270 × 16 HDS1R
265	2	291	2	-
285	2	311	2	-
305	2	341	2	-
330	2,1	369	2	-
350	2,1	389	2	CR 350 × 400 × 17 HDS1R
370	2,1	409	2	CR 370 × 420 × 25 HDS1R
390	2,1	429	2	-
415	2,1	469	2	-

¹⁾ The CR seals are described in catalogue 4006 "CR seals"

**Needle roller bearings with flanges,
with inner ring**
d 5 – 17 mm

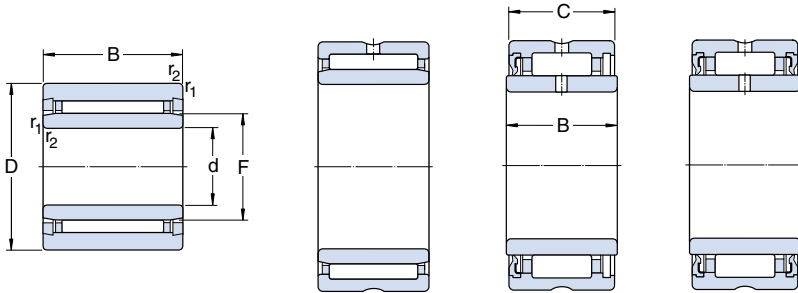

Series NKI
(d ≤ 7 mm)

Series NKI(S) (d ≥ 9 mm)
Series NA 49
Series NA 69

Series NA 49 RS

Series NA 49.2RS

Principal dimensions				Basic load ratings		Fatigue load limit P_u	Speed ratings		Mass	Designation
d	D	B	C	dynamic	C_0		Lubrication grease	oil		
mm				N		N	r/min	kg	–	
5	15	12	–	3 800	4 250	465	28 000	40 000	0,012	NKI 5/12 TN
	15	16	–	5 010	5 850	670	28 000	40 000	0,015	NKI 5/16 TN
6	16	12	–	4 400	5 200	570	24 000	36 000	0,014	NKI 6/12 TN
	16	16	–	5 720	7 200	815	24 000	36 000	0,017	NKI 6/16 TN
7	17	12	–	4 570	5 700	630	22 000	34 000	0,014	NKI 7/12 TN
	17	16	–	5 940	8 000	900	22 000	34 000	0,018	NKI 7/16 TN
9	19	12	–	6 710	8 150	965	19 000	30 000	0,017	NKI 9/12
	19	16	–	9 130	12 000	1 460	19 000	30 000	0,022	NKI 9/16
10	22	13	–	8 800	10 400	1 250	17 000	26 000	0,023	NA 4900
	22	14	13	7 370	8 150	950	13 000	13 000	0,025	NA 4900 RS
	22	14	13	7 370	8 150	950	13 000	–	0,025	NA 4900.2RS
	22	16	–	10 200	12 500	1 530	17 000	26 000	0,029	NKI 10/16
	22	20	–	12 800	16 600	2 080	17 000	26 000	0,037	NKI 10/20
12	24	13	–	9 900	12 200	1 460	16 000	24 000	0,026	NA 4901
	24	14	13	8 090	9 650	1 140	12 000	12 000	0,028	NA 4901 RS
	24	14	13	8 090	9 650	1 140	12 000	–	0,028	NA 4901.2RS
	24	16	–	11 700	15 300	1 860	16 000	24 000	0,033	NKI 12/16
	24	20	–	14 500	20 000	2 500	16 000	24 000	0,042	NKI 12/20
	24	20	–	16 100	23 200	2 900	16 000	24 000	0,046	NA 6901
15	27	16	–	13 400	19 000	2 320	14 000	20 000	0,039	NKI 15/16
	27	20	–	16 500	25 500	3 200	14 000	20 000	0,049	NKI 15/20
	28	13	–	11 200	15 300	1 830	13 000	19 000	0,034	NA 4902
	28	14	13	9 130	12 000	1 400	9 500	9 500	0,037	NA 4902 RS
	28	14	13	9 130	12 000	1 400	9 500	–	0,037	NA 4902.2RS
	28	23	–	17 200	27 000	3 400	13 000	19 000	0,064	NA 6902
17	29	16	–	13 800	20 400	2 500	13 000	19 000	0,042	NKI 17/16
	29	20	–	17 200	27 000	3 450	13 000	19 000	0,053	NKI 17/20
	30	13	–	11 400	16 300	1 960	12 000	18 000	0,037	NA 4903
	30	14	13	9 520	12 900	1 500	9 000	9 000	0,040	NA 4903 RS
	30	14	13	9 520	12 900	1 500	9 000	–	0,040	NA 4903.2RS
	30	23	–	18 700	30 500	3 900	12 000	18 000	0,072	NA 6903
	37	20	–	26 000	33 500	4 250	9 500	15 000	0,098	NKI 17

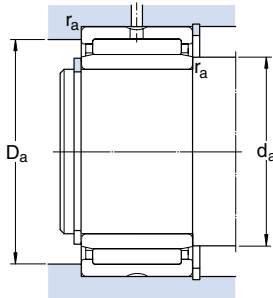

Dimensions

Abutment and fillet dimensions

d	F	$r_{1,2}$ min	s ¹⁾	d_a min	D_a max	r_a max
mm				mm		
5	8	0,3	1,5	7	13	0,3
	8	0,3	2	7	13	0,3
6	9	0,3	1,5	8	14	0,3
	9	0,3	2	8	14	0,3
7	10	0,3	1,5	9	15	0,3
	10	0,3	2	9	15	0,3
9	12	0,3	1,5	11	17	0,3
	12	0,3	2	11	17	0,3
10	14	0,3	0,5	12	20	0,3
	14	0,3	0,5	12	20	0,3
	14	0,3	0,5	12	20	0,3
	14	0,3	0,5	12	20	0,3
	14	0,3	0,5	12	20	0,3
12	16	0,3	0,5	14	22	0,3
	16	0,3	0,5	14	22	0,3
	16	0,3	0,5	14	22	0,3
	16	0,3	0,5	14	22	0,3
	16	0,3	0,5	14	22	0,3
	16	0,3	1	14	22	0,3
15	19	0,3	0,5	17	25	0,3
	19	0,3	0,5	17	25	0,3
	20	0,3	0,5	17	26	0,3
	20	0,3	0,5	17	26	0,3
	20	0,3	0,5	17	26	0,3
	20	0,3	1	17	26	0,3
17	21	0,3	0,5	19	27	0,3
	21	0,3	0,5	19	27	0,3
	22	0,3	0,5	19	28	0,3
	22	0,3	0,5	19	28	0,3
	22	0,3	0,5	19	28	0,3
	22	0,3	1	19	28	0,3
	24	0,6	0,5	21	33	0,6

¹⁾ Permissible axial displacement from normal position of one bearing ring in relation to the other

**Needle roller bearings with flanges,
with inner ring**
d 20 – 32 mm

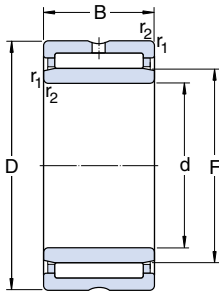

Series NKI(S)
Series NA 49
Series NA 69 (d ≤ 30 mm)

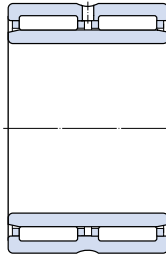

Series NA 69
(d ≥ 32 mm)

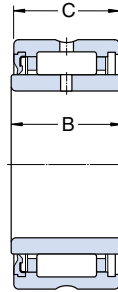

Series NA 49 RS

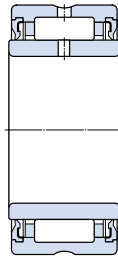

Series NA 49.2RS

Principal dimensions				Basic load ratings		Fatigue load limit P_u	Speed ratings		Mass kg	Designation
d	D	B	C	dynamic	static C_0		Lubrication grease	oil		
mm				N		N	r/min		kg	–
20	32	16	–	15 400	24 500	3 000	10 000	16 000	0,049	NKI 20/16
	32	20	–	19 000	32 500	4 050	10 000	16 000	0,061	NKI 20/20
	37	17	–	21 600	28 000	3 550	9 500	15 000	0,075	NA 4904
	37	18	17	19 400	22 400	2 750	7 500	7 500	0,080	NA 4904 RS
	37	18	17	19 400	22 400	2 750	7 500	–	0,080	NA 4904.2RS
	37	30	–	35 200	53 000	6 950	9 500	12 000	0,14	NA 6904
42	20	–	28 600	39 000	5 000	8 500	13 000	0,13	NKIS 20	
22	34	16	–	15 700	26 000	3 200	9 500	15 000	0,052	NKI 22/16
	34	20	–	19 400	34 500	4 300	9 500	15 000	0,065	NKI 22/20
	39	17	–	23 300	32 000	4 050	9 000	14 000	0,080	NA 49/22
	39	30	–	36 900	57 000	7 500	9 000	14 000	0,15	NA 69/22
25	38	20	–	22 000	36 500	4 650	9 000	14 000	0,079	NKI 25/20
	38	30	–	31 900	60 000	7 800	9 000	14 000	0,12	NKI 25/30
	42	17	–	24 200	34 500	4 300	8 500	13 000	0,088	NA 4905
	42	18	17	21 600	27 500	3 350	6 300	6 300	0,090	NA 4905 RS
	42	18	17	21 600	27 500	3 350	6 300	–	0,090	NA 4905.2RS
	42	30	–	38 000	62 000	8 150	8 500	13 000	0,16	NA 6905
47	22	–	34 100	46 500	6 000	8 000	12 000	0,16	NKIS 25	
28	42	20	–	23 300	40 500	5 200	8 000	12 000	0,097	NKI 28/20
	42	30	–	34 100	65 500	8 650	8 000	12 000	0,15	NKI 28/30
	45	17	–	25 100	36 500	4 550	8 000	12 000	0,098	NA 49/28
	45	30	–	39 600	65 500	8 650	8 000	12 000	0,18	NA 69/28
30	45	20	–	24 600	45 000	5 700	7 500	11 000	0,11	NKI 30/20
	45	30	–	35 800	72 000	9 500	7 500	11 000	0,17	NKI 30/30
	47	17	–	25 500	39 000	4 900	7 500	11 000	0,10	NA 4906
	47	18	17	23 300	32 000	3 900	5 600	5 600	0,10	NA 4906 RS
	47	18	17	23 300	32 000	3 900	5 600	–	0,10	NA 4906.2RS
	47	30	–	42 900	75 000	9 800	7 500	11 000	0,19	NA 6906
	52	22	–	36 000	54 000	6 950	7 000	10 000	0,18	NKIS 30
32	47	20	–	25 100	46 500	5 850	7 500	11 000	0,12	NKI 32/20
	47	30	–	36 900	76 500	10 000	7 500	11 000	0,18	NKI 32/30
	52	20	–	30 800	51 000	6 550	7 000	10 000	0,16	NA 49/32
	52	36	–	47 300	90 000	11 200	7 000	10 000	0,29	NA 69/32

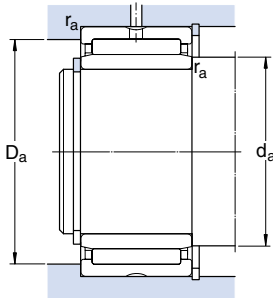

Dimensions

Abutment and fillet dimensions

d	F	r _{1,2} min	s ¹⁾	d _a min	D _a max	r _a max
mm				mm		
20	24	0,3	0,5	22	30	0,3
	24	0,3	0,5	22	30	0,3
	25	0,3	0,8	22	35	0,3
	25	0,3	0,5	22	35	0,3
	25	0,3	0,5	22	35	0,3
	25	0,3	1	22	35	0,3
	28	0,6	0,5	24	38	0,6
22	26	0,3	0,5	24	32	0,3
	26	0,3	0,5	24	32	0,3
	28	0,3	0,8	24	37	0,3
	28	0,3	0,5	24	37	0,3
25	29	0,3	1	27	36	0,3
	29	0,3	1,5	27	36	0,3
	30	0,3	0,8	27	40	0,3
	30	0,3	0,5	27	40	0,3
	30	0,3	0,5	27	40	0,3
	30	0,3	1	27	40	0,3
	32	0,6	1	29	43	0,6
28	32	0,3	1	30	40	0,3
	32	0,3	1,5	30	40	0,3
	32	0,3	0,8	30	43	0,3
	32	0,3	1	30	43	0,3
30	35	0,3	0,5	32	43	0,3
	35	0,3	1	32	43	0,3
	35	0,3	0,8	32	45	0,3
	35	0,3	0,5	32	45	0,3
	35	0,3	0,5	32	45	0,3
	35	0,3	1	32	45	0,3
	37	0,6	1	34	48	0,6
32	37	0,3	0,5	34	45	0,3
	37	0,3	1	34	45	0,3
	40	0,6	0,8	36	48	0,6
	40	0,6	0,5	36	48	0,6

¹⁾ Permissible axial displacement from normal position of one bearing ring in relation to the other



**Needle roller bearings with flanges,
with inner ring**
d 35 – 50 mm

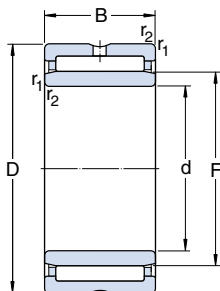

Series NKI(S)
Series NA 49

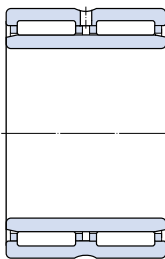

Series NA 69

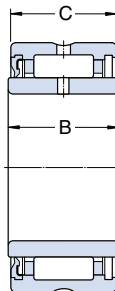

Series NA 49 RS



Series NA 49.2RS

Principal dimensions				Basic load ratings		Fatigue load limit	Speed ratings		Mass	Designation
d	D	B	C	C ₀	P ₀		Lubrication	grease oil		
mm				N		N	r/min		kg	–
35	50	20	–	26 400	51 000	6 400	7 000	10 000	0,13	NKI 35/20
	50	30	–	38 000	83 000	10 800	7 000	10 000	0,19	NKI 35/30
	55	20	–	31 900	54 000	6 950	6 700	9 500	0,17	NA 4907
	55	21	20	27 000	43 000	5 400	4 800	4 800	0,18	NA 4907 RS
	55	21	20	27 000	43 000	5 400	4 800	–	0,18	NA 4907.2RS
	55	36	–	48 400	93 000	11 800	6 700	9 500	0,31	NA 6907
58	22	–	39 100	61 000	7 800	6 300	9 000	0,22	NKIS 35	
38	53	20	–	27 500	55 000	6 950	6 700	9 500	0,14	NKI 38/20
	53	30	–	40 200	90 000	11 600	6 700	9 500	0,21	NKI 38/30
40	55	20	–	27 500	57 000	7 200	6 300	9 000	0,14	NKI 40/20
	55	30	–	40 200	93 000	12 000	6 300	9 000	0,22	NKI 40/30
	62	22	–	42 900	71 000	9 150	5 600	8 000	0,23	NA 4908
	62	23	22	36 900	58 500	7 350	4 000	4 000	0,25	NA 4908 RS
	62	23	22	36 900	58 500	7 350	4 000	–	0,25	NA 4908.2RS
	62	40	–	67 100	125 000	16 000	5 600	8 000	0,43	NA 6908
65	22	–	42 900	72 000	9 150	5 600	8 000	0,28	NKIS 40	
42	57	20	–	29 200	61 000	7 650	6 000	8 500	0,15	NKI 42/20
	57	30	–	41 800	98 000	12 900	6 000	8 500	0,22	NKI 42/30
45	62	25	–	38 000	78 000	10 000	5 600	8 000	0,23	NKI 45/25
	62	35	–	49 500	110 000	14 300	5 600	8 000	0,32	NKI 45/35
	68	22	–	45 700	78 000	10 000	5 300	7 500	0,27	NA 4909
	68	23	22	39 100	64 000	8 000	3 800	3 800	0,29	NA 4909 RS
	68	23	22	39 100	64 000	8 000	3 800	–	0,29	NA 4909.2RS
	68	40	–	70 400	137 000	17 300	5 300	7 500	0,50	NA 6909
72	22	–	44 600	78 000	10 000	5 000	7 000	0,34	NKIS 45	
50	68	25	–	40 200	88 000	11 200	5 300	7 500	0,27	NKI 50/25
	68	35	–	52 300	122 000	16 000	5 300	7 500	0,38	NKI 50/35
	72	22	–	47 300	85 000	11 000	5 000	7 000	0,27	NA 4910
	72	23	22	40 200	69 500	8 800	3 400	3 400	0,30	NA 4910 RS
	72	23	22	40 200	69 500	8 800	3 400	–	0,30	NA 4910.2RS
	72	40	–	73 700	150 000	19 000	5 000	7 000	0,52	NA 6910
	80	28	–	62 700	104 000	13 700	4 500	6 300	0,52	NKIS 50

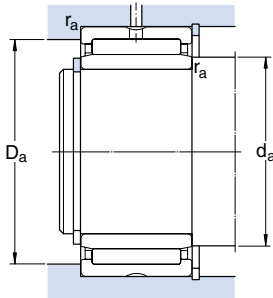

Dimensions

Abutment and fillet dimensions

d	F	$r_{1,2}$ min	$s^1)$	d_a min	D_a max	r_a max
mm				mm		
35	40	0,3	0,5	37	48	0,3
	40	0,3	1	37	48	0,3
	42	0,6	0,8	39	51	0,6
	42	0,6	0,5	39	51	0,6
	42	0,6	0,5	39	51	0,6
	42	0,6	0,5	39	51	0,6
43	43	0,6	0,5	39	54	0,6
	43	0,3	0,5	40	51	0,3
38	43	0,3	1	40	51	0,3
	43	0,3	1	40	51	0,3
40	45	0,3	0,5	42	53	0,3
	45	0,3	1	42	53	0,3
	48	0,6	1	44	58	0,6
	48	0,6	0,5	44	58	0,6
	48	0,6	0,5	44	58	0,6
	48	0,6	0,5	44	58	0,6
	50	1	0,5	45	60	1
42	47	0,3	0,5	44	55	0,3
	47	0,3	1	44	55	0,3
45	50	0,6	1,5	49	58	0,6
	50	0,6	2	49	58	0,6
	52	0,6	1	49	64	0,6
	52	0,6	0,5	49	64	0,6
	52	0,6	0,5	49	64	0,6
	52	0,6	0,5	49	64	0,6
	55	1	0,5	50	67	1
50	55	0,6	1,5	54	64	0,6
	55	0,6	2	54	64	0,6
	58	0,6	1	54	68	0,6
	58	0,6	0,5	54	68	0,6
	58	0,6	0,5	54	68	0,6
	58	0,6	0,5	54	68	0,6
	60	1,1	2	56,5	73,5	1

¹⁾ Permissible axial displacement from normal position of one bearing ring in relation to the other



**Needle roller bearings with flanges,
with inner ring**
d 55 – 85 mm

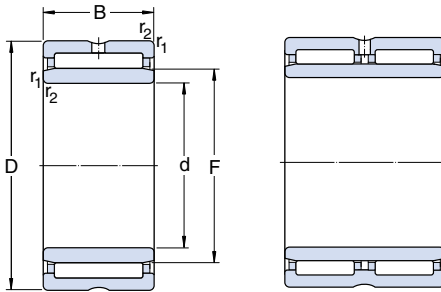

Series NKI(S)
Series NA 49

Series NA 69

Principal dimensions			Basic load ratings		Fatigue load limit P_u	Speed ratings		Mass	Designation
d	D	B	dynamic	static C_0		Lubrication grease	oil		
mm			N		N	r/min		kg	–
55	72	25	41 800	96 500	12 200	4 800	6 700	0,27	NKI 55/25
	72	35	55 000	134 000	17 600	4 800	6 700	0,38	NKI 55/35
	80	25	57 200	106 000	13 700	4 500	6 300	0,39	NA 4911
	80	45	89 700	190 000	24 000	4 500	6 300	0,78	NA 6911
	85	28	66 000	114 000	15 000	4 300	6 000	0,56	NKIS 55
60	82	25	44 000	95 000	12 000	4 300	6 000	0,39	NKI 60/25
	82	35	60 500	146 000	19 000	4 300	6 000	0,55	NKI 60/35
	85	25	60 500	114 000	14 600	4 300	6 000	0,43	NA 4912
	85	45	93 500	204 000	26 000	4 300	6 000	0,81	NA 6912
	90	28	68 200	120 000	15 600	4 000	5 600	0,56	NKIS 60
65	90	25	61 600	120 000	15 300	4 000	5 600	0,46	NA 4913
	90	45	95 200	212 000	27 000	4 000	5 600	0,83	NA 6913
	90	25	52 800	106 000	13 700	4 000	5 600	0,47	NKI 65/25
	90	35	73 700	163 000	21 600	4 000	5 600	0,66	NKI 65/35
	95	28	70 400	132 000	17 000	3 800	5 300	0,64	NKIS 65
70	95	25	56 100	127 000	16 000	3 600	5 000	0,52	NKI 70/25
	95	35	76 500	190 000	25 000	3 600	5 000	0,74	NKI 70/35
	100	30	84 200	163 000	21 600	3 600	5 000	0,73	NA 4914
	100	54	128 000	285 000	37 500	3 600	5 000	1,35	NA 6914
75	105	25	69 300	132 000	17 000	3 400	4 800	0,64	NKI 75/25
	105	30	84 200	170 000	22 400	3 400	4 800	0,78	NA 4915
	105	35	96 800	200 000	27 000	3 400	4 800	0,91	NKI 75/35
	105	54	130 000	290 000	38 000	3 400	4 800	1,45	NA 6915
80	110	25	72 100	140 000	18 300	3 200	4 500	0,68	NKI 80/25
	110	30	88 000	183 000	24 000	3 200	4 500	0,88	NA 4916
	110	35	101 000	216 000	29 000	3 200	4 500	0,96	NKI 80/35
	110	54	134 000	315 000	41 500	3 200	4 500	1,50	NA 6916
85	115	26	73 700	146 000	19 000	3 000	4 300	0,74	NKI 85/26
	115	36	105 000	232 000	30 500	3 000	4 300	1,05	NKI 85/36
	120	35	108 000	250 000	32 000	2 800	4 000	1,25	NA 4917
	120	63	165 000	425 000	54 000	2 800	4 000	2,20	NA 6917

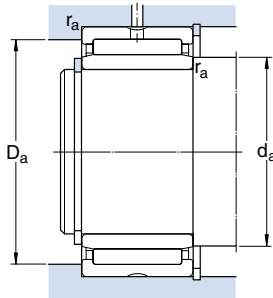

Dimensions

**Abutment and
fillet dimensions**

d	F	r _{1,2} min	s ¹⁾	d _a min	D _a max	r _a max
mm				mm		
55	60	0,6	1,5	59	68	0,6
	60	0,6	2	59	68	0,6
	63	1	1,5	60	75	1
	63	1	1,5	60	75	1
	65	1,1	2	61,5	78,5	1
60	68	0,6	1	64	78	0,6
	68	0,6	1	64	78	0,6
	68	1	1,5	65	80	1
	68	1	1,5	65	80	1
	70	1,1	2	66,5	83,5	1
65	72	1	1,5	70	85	1
	72	1	1,5	70	85	1
	73	1	1	70	85	1
	73	1	1	70	85	1
	75	1,1	2	71,5	88,5	1
70	80	1	0,8	75	90	1
	80	1	0,8	75	90	1
	80	1	1,5	75	95	1
	80	1	1	75	95	1
75	85	1	1	80	100	1
	85	1	1,5	80	100	1
	85	1	1	80	100	1
	85	1	1	80	100	1
80	90	1	1	85	105	1
	90	1	1,5	85	105	1
	90	1	1	85	105	1
	90	1	1	85	105	1
85	95	1	1,5	90	110	1
	95	1	1,5	90	110	1
	100	1,1	1	91,5	113,5	1
	100	1,1	1	91,5	113,5	1

¹⁾ Permissible axial displacement from normal position of one bearing ring in relation to the other



**Needle roller bearings with flanges,
with inner ring**
d 90 – 220 mm

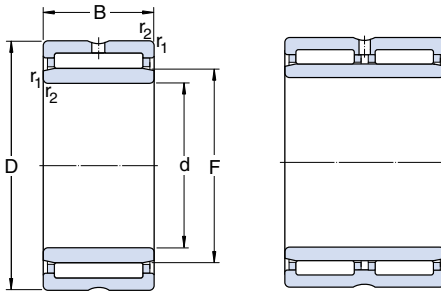

Series NKI
Series NA 49

Series NA 69

Principal dimensions			Basic load ratings		Fatigue load limit P_u	Speed ratings		Mass	Designation
d	D	B	dynamic	C_0		Lubrication	oil		
mm			N		N	r/min		kg	–
90	120	26	76 500	156 000	19 600	2 800	4 000	0,78	NKI 90/26
	120	36	108 000	250 000	32 000	2 800	4 000	1,10	NKI 90/36
	125	35	112 000	265 000	33 500	2 600	3 800	1,30	NA 4918
	125	63	172 000	450 000	57 000	2 600	3 800	2,30	NA 6918
95	125	26	78 100	166 000	20 800	2 600	3 800	0,82	NKI 95/26
	125	36	112 000	265 000	33 500	2 600	3 800	1,15	NKI 95/36
	130	35	114 000	270 000	34 000	2 400	3 600	1,35	NA 4919
	130	63	172 000	465 000	57 000	2 400	3 600	2,50	NA 6919
100	130	30	96 800	220 000	27 500	2 400	3 600	0,99	NKI 100/30
	130	40	123 000	305 000	38 000	2 400	3 600	1,35	NKI 100/40
	140	40	125 000	280 000	34 500	2 200	3 400	1,90	NA 4920
110	140	30	93 500	232 000	27 500	2 200	3 400	1,10	NA 4822
	150	40	130 000	300 000	36 500	2 000	3 200	2,05	NA 4922
120	150	30	99 000	255 000	30 000	2 000	3 200	1,15	NA 4824
	165	45	176 000	405 000	47 500	1 900	3 000	2,85	NA 4924
130	165	35	119 000	325 000	37 500	1 800	2 800	1,80	NA 4826
	180	50	198 000	480 000	55 000	1 700	2 600	3,90	NA 4926
140	175	35	121 000	345 000	38 000	1 700	2 600	1,90	NA 4828
	190	50	205 000	510 000	58 500	1 600	2 400	4,15	NA 4928
150	190	40	147 000	415 000	46 500	1 600	2 400	2,70	NA 4830
160	200	40	157 000	450 000	50 000	1 500	2 200	2,90	NA 4832
170	215	45	179 000	520 000	57 000	1 500	2 200	3,95	NA 4834
180	225	45	190 000	570 000	60 000	1 400	2 000	4,20	NA 4836
190	240	50	220 000	710 000	73 500	1 300	1 900	5,60	NA 4838
200	250	50	224 000	735 000	75 000	1 200	1 800	5,85	NA 4840
220	270	50	238 000	815 000	81 500	1 100	1 700	6,40	NA 4844

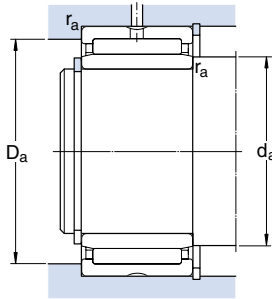

Dimensions

Abutment and fillet dimensions

d	F	$r_{1,2}$ min	$s^{1)}$	d_a min	D_a max	r_a max
mm				mm		
90	100	1	1,5	95	115	1
	100	1	1,5	95	115	1
	105	1,1	1	96,5	118,5	1
	105	1,1	1	96,5	118,5	1
95	105	1	1,5	100	120	1
	105	1	1,5	100	120	1
	110	1,1	1	101,5	123,5	1
	110	1,1	1	101,5	123,5	1
100	110	1,1	1,5	106,5	123,5	1
	110	1,1	2	106,5	123,5	1
	115	1,1	2	106,5	133,5	1
110	120	1	0,8	115	135	1
	125	1,1	2	116,5	143,5	1
120	130	1	0,8	125	145	1
	135	1,1	2	126,5	158,5	1
130	145	1,1	1	136,5	158,5	1
	150	1,5	1,5	138	172	1,5
140	155	1,1	1	146,5	168,5	1
	160	1,5	1,5	148	182	1,5
150	165	1,1	1,5	156,5	183,5	1
160	175	1,1	1,5	166,5	193,5	1
170	185	1,1	1,5	176,5	208,5	1
180	195	1,1	1,5	186,5	218,5	1
190	210	1,5	1,5	198	232	1,5
200	220	1,5	1,5	208	242	1,5
220	240	1,5	1,5	228	262	1,5

¹⁾ Permissible axial displacement from normal position of one bearing ring in relation to the other

**Needle roller bearings with flanges,
with inner ring**
d 240 – 380 mm

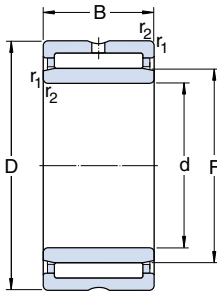

Principal dimensions			Basic load ratings		Fatigue load limit P_u	Speed ratings		Mass	Designation
d	D	B	dynamic C	static C_0		Lubrication grease	oil		
mm			N		N	r/min		kg	–
240	300	60	347 000	1 120 000	108 000	950	1 500	10,0	NA 4848
260	320	60	358 000	1 200 000	114 000	900	1 400	10,5	NA 4852
280	350	69	429 000	1 320 000	127 000	850	1 300	15,5	NA 4856
300	380	80	594 000	1 800 000	170 000	750	1 100	22,0	NA 4860
320	400	80	605 000	1 900 000	176 000	750	1 100	23,0	NA 4864
340	420	80	616 000	1 960 000	180 000	700	1 000	24,0	NA 4868
360	440	80	627 000	2 040 000	186 000	670	950	25,5	NA 4872
380	480	100	968 000	3 000 000	265 000	630	900	42,5	NA 4876

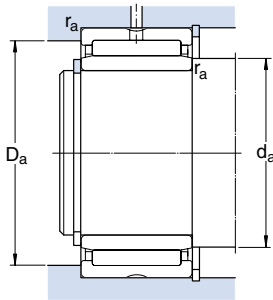

Dimensions

**Abutment and
fillet dimensions**

d	F	$r_{1,2}$ min	$s^1)$	d_a min	D_a max	r_a max
mm				mm		
240	265	2	2	249	291	2
260	285	2	2	269	311	2
280	305	2	2,5	289	341	2
300	330	2,1	2	311	369	2
320	350	2,1	2	331	389	2
340	370	2,1	2	351	409	2
360	390	2,1	2	371	429	2
380	415	2,1	2	391	469	2

¹⁾ Permissible axial displacement from normal position of one bearing ring in relation to the other

Needle roller bearings without flanges, without inner ring

F_w 5 – 30 mm

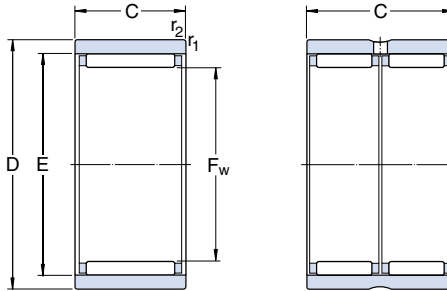

Principal dimensions			Basic load ratings		Fatigue load limit P _u	Speed ratings		Mass	Designation
F _w	D	C	dynamic C	static C ₀		Lubrication grease	oil		
mm			N		N	r/min		kg	–
5	10	8	2 290	2 000	212	24 000	36 000	0,003	RNAO 5×10×8 TN
6	13	8	2 550	2 360	250	22 000	34 000	0,006	RNAO 6×13×8 TN
7	14	8	2 810	2 750	290	20 000	32 000	0,006	RNAO 7×14×8 TN
8	15	10	3 800	4 250	465	20 000	32 000	0,008	RNAO 8×15×10 TN
10	17	10	4 570	5 700	630	19 000	30 000	0,010	RNAO 10×17×10 TN
12	22	12	9 520	10 000	1 180	17 000	26 000	0,019	RNAO 12×22×12 TN
15	23	13	8 090	10 800	1 250	16 000	24 000	0,020	RNAO 15×23×13
16	24	13	8 580	12 000	1 370	16 000	24 000	0,021	RNAO 16×24×13
	28	12	11 000	12 500	1 500	15 000	22 000	0,032	RNAO 16×28×12
17	25	13	10 100	14 600	1 730	15 000	22 000	0,022	RNAO 17×25×13
18	30	24	20 900	30 000	3 600	14 000	20 000	0,069	RNAO 18×30×24¹⁾
20	28	13	9 520	14 600	1 660	14 000	20 000	0,025	RNAO 20×28×13
	28	26	16 100	29 000	3 350	14 000	20 000	0,050	RNAO 20×28×26¹⁾
	32	12	12 800	16 300	1 960	13 000	19 000	0,038	RNAO 20×32×12
22	30	13	10 100	16 300	1 860	12 000	18 000	0,027	RNAO 22×30×13
	35	16	19 400	25 500	3 050	11 000	17 000	0,059	RNAO 22×35×16
25	35	17	14 200	26 500	3 100	10 000	16 000	0,053	RNAO 25×35×17
	35	26	18 700	37 500	4 300	10 000	16 000	0,076	RNAO 25×35×26¹⁾
	37	16	20 100	28 000	3 350	9 500	15 000	0,060	RNAO 25×37×16
30	40	17	18 700	34 000	4 050	8 500	13 000	0,060	RNAO 30×40×17
	42	16	22 000	33 500	4 000	8 500	13 000	0,059	RNAO 30×42×16
	42	32	38 000	67 000	8 000	8 500	13 000	0,14	RNAO 30×42×32¹⁾

¹⁾ Double row

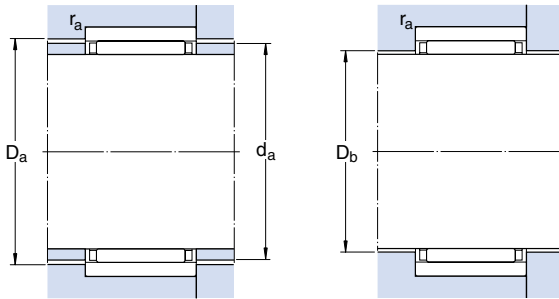
Dimensions
**Abutment and
fillet dimensions**

F_w	E	$r_{1,2}$ min	d_a	D_a	D_b	r_a max
mm		mm				
5	8	0,15	7,7	8,3	5,3	0,1
6	9	0,3	8,7	9,3	6,3	0,3
7	10	0,3	9,7	10,3	7,3	0,3
8	11	0,3	10,7	11,3	8,3	0,3
10	13	0,3	12,7	13,3	10,3	0,3
12	18	0,3	17,6	18,3	12,3	0,3
15	19	0,3	18,6	19,3	15,4	0,3
16	20	0,3	19,6	20,3	16,4	0,3
	22	0,3	21,6	22,3	16,4	0,3
17	21	0,3	20,6	21,3	17,4	0,3
18	24	0,3	23,6	24,5	18,4	0,3
20	24	0,3	23,6	24,3	20,4	0,3
	24	0,3	23,6	24,3	20,4	0,3
	26	0,3	25,6	26,5	20,4	0,3
22	26	0,3	25,6	26,3	22,4	0,3
	29	0,3	28,4	29,5	22,4	0,3
25	30	0,3	29,4	30,5	25,6	0,3
	30	0,3	29,4	30,5	25,6	0,3
	32	0,3	31,4	32,5	25,6	0,3
30	35	0,3	34,4	35,5	30,6	0,3
	37	0,3	36,4	37,5	30,6	0,3
	37	0,3	36,4	37,5	30,6	0,3

Needle roller bearings without flanges, without inner ring

F_w 35 – 100 mm

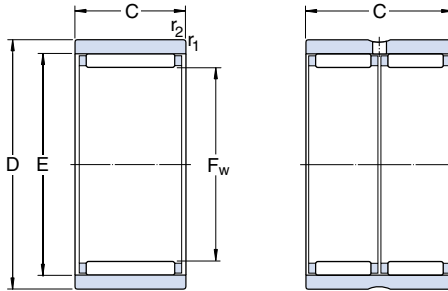

Principal dimensions			Basic load ratings		Fatigue load limit P _u	Speed ratings		Mass	Designation
F _w	D	C	dynamic	static		Lubrication	oil		
mm			C	C ₀	N	r/min	kg	-	
35	45	13	15 400	28 000	3 250	8 000	12 000	0,053	RNAO 35×45×13
	45	17	19 800	39 000	4 650	8 000	12 000	0,069	RNAO 35×45×17
	45	26	26 400	56 000	6 550	8 000	12 000	0,091	RNAO 35×45×26¹⁾
	47	16	23 300	37 500	4 500	7 500	11 000	0,078	RNAO 35×47×16
	47	18	26 400	44 000	5 300	7 500	11 000	0,089	RNAO 35×47×18
	47	32	40 200	75 000	9 000	7 500	11 000	0,16	RNAO 35×47×32¹⁾
40	50	17	20 500	41 500	5 000	7 000	10 000	0,074	RNAO 40×50×17
	50	34	35 200	83 000	10 000	7 000	10 000	0,15	RNAO 40×50×34¹⁾
	55	20	31 400	57 000	6 950	7 000	10 000	0,15	RNAO 40×55×20
	55	40	59 400	118 000	14 600	7 000	10 000	0,28	RNAO 40×55×40¹⁾
45	55	17	21 600	46 500	5 600	6 300	9 000	0,083	RNAO 45×55×17
	62	40	64 400	137 000	16 600	6 300	9 000	0,38	RNAO 45×62×40¹⁾
50	62	20	25 500	60 000	7 200	6 000	8 500	0,14	RNAO 50×62×20
	65	20	34 100	62 000	7 650	5 600	8 000	0,17	RNAO 50×65×20
	65	40	58 300	125 000	15 300	5 600	8 000	0,36	RNAO 50×65×40
55	68	20	27 000	67 000	8 150	5 300	7 500	0,17	RNAO 55×68×20
60	78	20	41 800	86 500	10 600	4 800	6 700	0,26	RNAO 60×78×20
	78	40	72 100	173 000	21 200	4 800	6 700	0,44	RNAO 60×78×40
65	85	30	53 900	125 000	15 600	4 500	6 300	0,46	RNAO 65×85×30
70	90	30	57 200	137 000	17 000	4 300	6 000	0,50	RNAO 70×90×30
80	100	30	68 200	176 000	22 000	3 600	5 000	0,58	RNAO 80×100×30
90	105	26	58 300	150 000	18 600	3 200	4 500	0,37	RNAO 90×105×26
	110	30	64 400	173 000	21 600	3 200	4 500	0,61	RNAO 90×110×30
100	120	30	67 100	190 000	23 600	2 800	4 000	0,69	RNAO 100×120×30

¹⁾ Double row

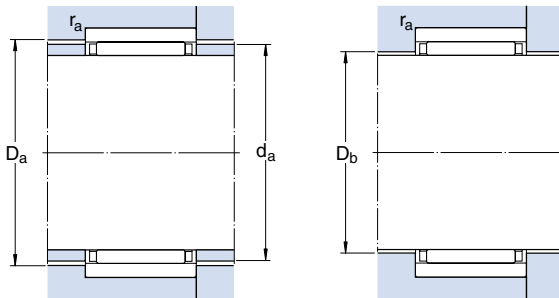

Dimensions

Abutment and fillet dimensions

F _w	E	r _{1,2} min	d _a	D _a	D _b	r _a max
mm			mm			
35	40	0,3	39,4	40,5	35,6	0,3
	40	0,3	39,4	40,5	35,6	0,3
	40	0,3	39,4	40,5	35,6	0,3
	42	0,3	41,4	42,5	35,8	0,3
	42	0,3	41,4	42,5	35,6	0,3
	42	0,3	41,4	42,5	35,6	0,3
40	45	0,3	44,4	45,5	40,6	0,3
	45	0,3	44,4	45,5	40,6	0,3
	47	0,3	46,2	47,5	40,6	0,3
	48	0,3	47,2	47,5	40,6	0,3
45	50	0,3	49,4	50,5	45,6	0,3
	53	0,3	52,2	53,5	46	0,3
50	55	0,3	54,4	55,8	50,6	0,3
	58	0,3	57,2	58,5	51	0,3
	58	0,3	57,2	58,5	51	0,3
55	60	0,3	59,4	60,8	55,6	0,3
60	68	1	67,2	68,8	61	1
	68	1	67,2	68,8	61	1
65	73	1	72,2	73,8	66	1
70	78	1	77,2	78,8	71	1
80	88	1	87,2	89	81	1
90	98	1	97,2	99	91	1
	98	1	97,2	99	91	1
100	108	1	107,2	109	101	1

**Needle roller bearings without flanges,
with inner ring**
d 6 – 90 mm

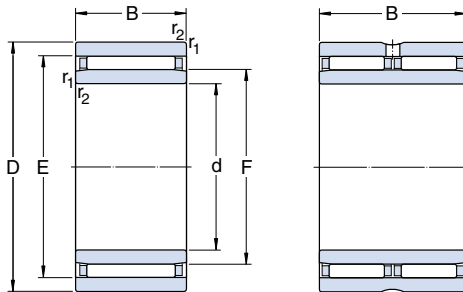

Principal dimensions			Basic load ratings		Fatigue load limit P_u	Speed ratings		Mass	Designation
d	D	B	dynamic C	static C_0		Lubrication grease	oil		
mm			N		N	r/min		kg	–
6	17	10	4 570	5 700	630	18 000	28 000	0,014	NAO 6×17×10 TN¹⁾
9	22	12	9 520	10 000	1 180	17 000	26 000	0,024	NAO 9×22×12 TN
12	24	13	8 580	12 000	1 370	16 000	24 000	0,030	NAO 12×24×13
	28	12	11 000	12 500	1 500	15 000	22 000	0,040	NAO 12×28×12
15	28	13	9 520	14 600	1 660	14 000	20 000	0,029	NAO 15×28×13
	32	12	12 800	16 300	1 960	13 000	19 000	0,050	NAO 15×32×12¹⁾
17	30	13	10 100	16 300	1 860	12 000	18 000	0,042	NAO 17×30×13
	35	16	19 400	25 500	3 050	11 000	17 000	0,078	NAO 17×35×16
20	35	17	14 200	26 500	3 100	10 000	16 000	0,076	NAO 20×35×17
	37	16	20 100	28 000	3 350	9 500	15 000	0,082	NAO 20×37×16
25	40	17	18 700	34 000	4 050	8 500	13 000	0,088	NAO 25×40×17
	42	16	22 000	33 500	4 000	8 500	13 000	0,086	NAO 25×42×16¹⁾
	42	32	38 000	68 000	8 150	8 500	13 000	0,19	NAO 25×42×32²⁾
30	45	17	19 800	39 000	4 650	8 000	12 000	0,10	NAO 30×45×17
	45	26	26 400	56 000	6 550	8 000	12 000	0,16	NAO 30×45×26²⁾
	47	16	23 300	37 500	4 500	7 500	11 000	0,11	NAO 30×47×16
	47	18	26 400	44 000	5 300	7 500	11 000	0,12	NAO 30×47×18
35	50	17	20 500	41 500	5 000	7 000	10 000	0,11	NAO 35×50×17
	55	20	31 400	57 000	6 950	7 000	10 000	0,19	NAO 35×55×20
40	55	17	21 600	46 500	5 600	6 300	9 000	0,13	NAO 40×55×17
50	68	20	27 000	67 000	8 150	5 300	7 500	0,23	NAO 50×68×20¹⁾
70	100	30	68 200	176 000	22 000	3 600	5 000	0,85	NAO 70×100×30
80	110	30	64 400	173 000	21 600	3 200	4 500	0,92	NAO 80×110×30
90	120	30	67 100	190 000	23 600	2 800	4 000	1,05	NAO 90×120×30

¹⁾ With one lubrication hole in the inner ring

²⁾ Double row

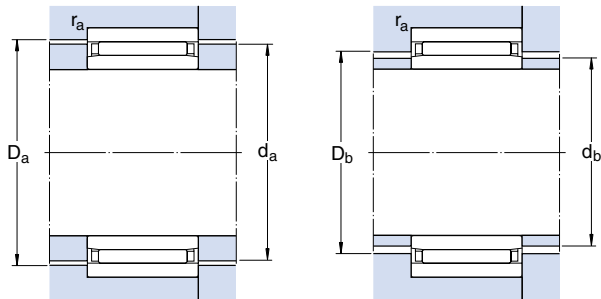

Dimensions

Abutment and fillet dimensions

d	E	F	$r_{1,2}$ min	$s^1)$	d_a	d_b	D_a	D_b	r_a max
mm					mm				
6	13	10	0,3	0,5	12,7	9,7	13,3	10,3	0,3
9	18	12	0,3	0,5	17,6	11,7	18,3	12,3	0,3
12	20	16	0,3	0,5	19,6	15,7	20,3	16,4	0,3
	22	16	0,3	0,5	21,6	15,7	22,3	16,6	0,3
15	24	20	0,3	0,5	23,6	19,5	24,3	20,4	0,3
	26	20	0,3	0,5	25,6	19,5	26,5	20,6	0,3
17	26	22	0,3	0,5	25,6	21,5	26,3	22,4	0,3
	29	22	0,3	0,5	28,4	21,5	29,5	22,6	0,3
20	30	25	0,3	0,5	29,4	24,5	30,5	25,6	0,3
	32	25	0,3	0,5	31,4	24,5	32,5	25,6	0,3
25	35	30	0,3	0,8	34,4	29,5	35,5	30,6	0,3
	37	30	0,3	0,8	36,4	29,5	37,5	30,6	0,3
	37	30	0,3	0,8	36,4	29,5	37,5	30,6	0,3
30	40	35	0,3	0,8	39,4	34,5	40,5	35,6	0,3
	40	35	0,3	0,8	39,4	34,5	40,5	35,6	0,3
	42	35	0,3	0,8	41,4	34,5	42,5	35,6	0,3
	42	35	0,3	0,8	41,4	34,5	42,5	35,6	0,3
35	45	40	0,3	0,8	44,4	39,5	45,5	40,6	0,3
	48	40	0,3	0,8	46,2	39,5	47,5	40,6	0,3
40	50	45	0,3	0,8	49,2	44,5	50,5	45,6	0,3
50	60	55	0,6	1	59,2	54,5	60,8	55,8	0,6
70	88	80	1	1	87,2	79,3	89	81	1
80	98	90	1	1	97,2	89,3	99	91	1
90	108	100	1	1	107,2	99,3	109	101	1

¹⁾ Permissible axial displacement from normal position of one bearing ring in relation to the other



Alignment needle roller bearings

Product tables

Alignment needle roller bearings without inner ring	page 112
Alignment needle roller bearings with inner ring	page 114

SKF alignment needle roller bearings have an outer ring with a convex sphered outside surface. A plastic seating ring having a concave sphered inside surface and encased in a drawn sheet steel sleeve is fitted over the outer ring, thus enabling the bearing to align itself. Alignment needle roller bearings are therefore insensitive to errors of alignment of the shaft relative to the housing. They are mounted with an interference fit in the housing bore. No shoulders or retaining rings etc. are required to locate the bearings axially so that the housing bore can be simply and economically machined.

Alignment needle roller bearings can be supplied without inner ring (→ **fig 1**) or with inner ring (→ **fig 2**). Bearings without inner

ring provide the optimum solution for arrangements where the shaft can be hardened and ground. Where this is not possible or not economic bearings with inner ring should be used. Bearings with inner ring only permit axial displacement of the shaft relative to the housing within certain limits. If greater axial displacements can occur extended inner rings, which are wider than the standard inner rings can be used; details will be found in the section “Inner rings” (→ **page 204**). The extended inner rings should also be used if the inner ring raceway is to serve as a counterface for a seal adjacent to the bearing.

All alignment needle roller bearings have a form-stable steel cage with adequate free space for lubricant. The needle rollers are

Fig 1

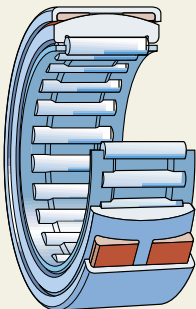
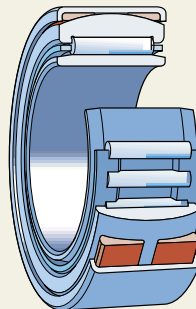

Fig 2



Alignment needle roller bearings

slightly relieved at their ends. The resulting modified line contact between rollers and raceways mean that the stress distribution in the bearing is improved.

Dimensions

The dimensions of alignment needle roller bearings have not been standardised. However, the bore and outside diameters of the smaller sizes follow Diameter Series 0 and those of the larger sizes follow Diameter Series 9 according to ISO 15:1998.

Tolerances

The inner ring and outer ring with sphered outside surface are made to Normal tolerances in accordance with ISO 492:1994 (→ Table 2, page 17).

The tolerance for the width of the external drawn steel sleeve is $\pm 0,5$ mm.

Internal clearance

Alignment needle roller bearings with inner ring are supplied with Normal radial internal clearance as standard as specified in ISO 5753:1991 (→ Table 6, page 21).

For the bearings without inner ring, series RPNA, the inside diameter F_w of the roller complement when the rollers are in contact with the outer ring raceway lies within tolerance F6 when the bearings are in the unmounted condition. If the recommended raceway tolerances are applied (→ “Shaft and housing tolerances”) the clearance in the bearing arrangement will be normal.

Misalignment

Alignment needle roller bearings can compensate for initial errors of alignment between shaft and housing of up to approximately 3° . They are not suitable for the accommodation of tilting or wobbling movement, however.

Permissible operating temperature

The plastic seating ring material limits the operating temperature range for alignment needle roller bearings to between -30 and $+100^\circ\text{C}$.

Cages

SKF alignment needle roller bearings are fitted with a steel (→ fig 3) or sheet steel cage (→ fig 4).

Shaft and housing tolerances

Alignment needle roller bearings should have an interference fit in the housing bore. If the recommended housing bore tolerances (→ Table 11) are applied alignment movements between the outer ring and the outer sleeve will be possible. These tolerances, together with the tolerances recommended for the inner ring shaft seatings or for raceways on the shaft will give the bearings a normal operational radial internal clearance.

Fig 3

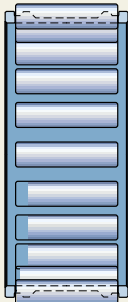

Fig 4



Fig 5

Raceways on the shaft

If the full load carrying capacity of the alignment needle roller bearings without inner ring is to be exploited, the raceways on the shaft must have the hardness and surface finish normally found on bearing raceways. Recommendations for suitable materials, surface roughness and hardness will be found in the section “Raceways on shafts and in housings” (→ page 28).

Mounting instructions

When mounting alignment needle roller bearings, any inner rings are separable and should be mounted separately. The outer ring with sleeve and needle roller and cage assembly should be mounted with the aid of a mandrel as shown in (→ fig 5). An O-ring provides a simple means of retaining the bearing on the mandrel. The stamped (hardened) side face of the sleeve should preferably abut the flange of the mandrel. Care should be taken to see that the sleeve does not tilt as it is pressed into the housing bore.

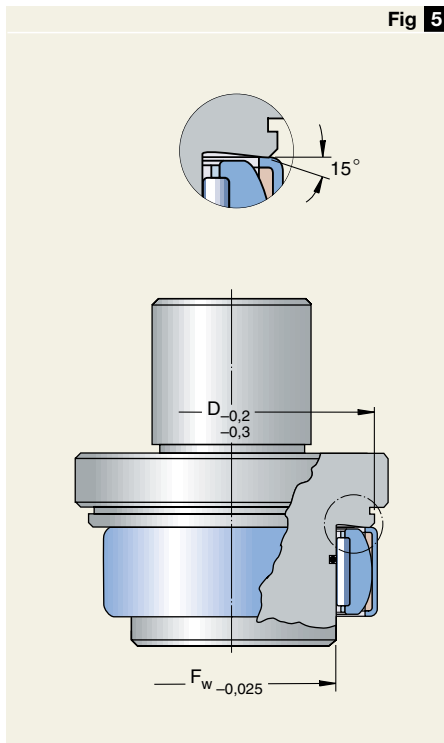

3

Table 1

Shaft and housing tolerances			
Housing material	Tolerances Seating in housing bore	Shaft seating for inner ring	Raceway on shaft
Steel, cast iron	N6	k5	h5
	N7	j6	h6
Light alloy	R6	k5	h5
	R7	j6	h6

Alignment needle roller bearings

Minimum load

In order to guarantee satisfactory operation, alignment needle roller bearings, like all ball and roller bearings, must always be subjected to a given minimum load, particularly if they are to operate at high speeds or are subjected to high accelerations or rapid changes in the direction of load. Under such conditions the inertia forces of the needle rollers and cage, and the friction in the lubricant, can have a detrimental influence on the rolling conditions in the bearing arrangement and may cause damaging sliding movements to occur between the rollers and raceways.

The requisite minimum radial load to be applied to alignment needle roller bearings can be estimated using

$$F_{rm} = 0,02 C$$

where

F_{rm} = minimum radial load, N

C = basic dynamic load rating, N

When starting up at low temperatures or when the lubricant is highly viscous, even greater loads may be required. The weights of the components supported by the bearing, together with the external forces, generally exceed the requisite minimum load. If this is not the case, the alignment needle roller bearing must be subjected to an additional radial load.

Equivalent dynamic bearing load

Alignment needle roller bearings can only take radial loads, therefore

$$P = F_r$$

Equivalent static bearing load

Alignment needle roller bearings can only take radial loads, therefore

$$P_0 = F_r$$

Alignment needle roller bearings without inner ring

F_w 15 – 45 mm

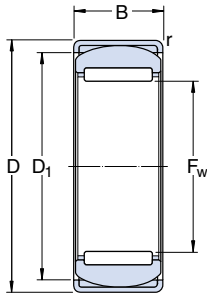

Principal dimensions			Basic load ratings		Fatigue load limit P_u	Speed ratings		Mass	Designation
F_w	D	B	dynamic C	static C_0		Lubrication grease	oil		
mm			N		N	r/min		kg	–
15	28	12	7 370	9 150	1 080	16 000	24 000	0,032	RPNA 15/28
18	32	16	12 800	17 600	2 120	15 000	22 000	0,052	RPNA 18/32
20	35	16	13 200	19 300	2 280	13 000	19 000	0,062	RPNA 20/35
25	42	20	19 000	32 500	4 000	10 000	16 000	0,11	RPNA 25/42
28	44	20	22 000	36 500	4 550	9 000	14 000	0,11	RPNA 28/44
30	47	20	22 900	38 000	4 800	8 500	13 000	0,13	RPNA 30/47
35	52	20	24 600	45 000	5 600	7 500	11 000	0,13	RPNA 35/52
40	55	20	26 400	51 000	6 300	7 000	10 000	0,14	RPNA 40/55
45	62	20	27 500	57 000	7 100	6 300	9 000	0,18	RPNA 45/62

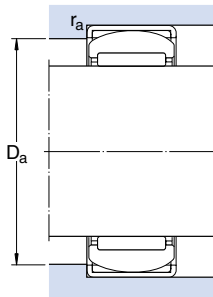

Dimensions

Abutment and fillet dimensions

F_w	D_1	r_{\min}	$D_{a\min}$	$D_{a\max}$	$r_{a\max}$
mm			mm		
15	24,5	1	23,5	24,5	1
18	27	1	26	27	1
20	30,5	1	29,5	30,5	1
25	36,5	1	35	37	1
28	38,5	1	37,5	39	1
30	42	1	41	42	1
35	47,5	1	46,5	47,5	1
40	50,5	1	49,5	50,5	1
45	58	1	57	58	1

Alignment needle roller bearings with inner ring
d 12–40 mm

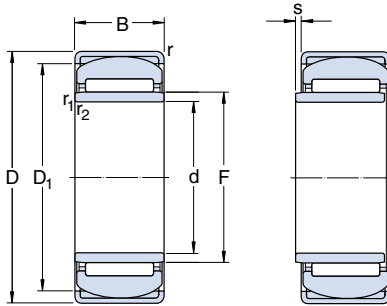

Principal dimensions			Basic load ratings		Fatigue load limit P_u	Speed ratings		Mass	Designation
d	D	B	dynamic C	static C_0		Lubrication grease	oil		
mm			N		N	r/min		kg	–
12	28	12	7 370	9 150	1 080	16 000	24 000	0,037	PNA 12/28
15	32	16	12 800	17 600	2 120	15 000	22 000	0,062	PNA 15/32
17	35	16	13 200	19 300	2 280	13 000	19 000	0,073	PNA 17/35
20	42	20	19 000	32 500	4 000	10 000	16 000	0,14	PNA 20/42
22	44	20	22 000	36 500	4 550	9 000	14 000	0,15	PNA 22/44
25	47	20	22 900	38 000	4 800	8 500	13 000	0,16	PNA 25/47
30	52	20	24 600	45 000	5 600	7 500	11 000	0,18	PNA 30/52
35	55	20	26 400	51 000	6 300	7 000	10 000	0,18	PNA 35/55
40	62	20	27 500	57 000	7 100	6 300	9 000	0,23	PNA 40/62

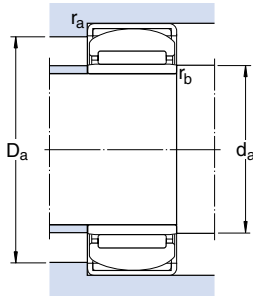

Dimensions

Abutment and fillet dimensions

d	F	D ₁	r _{min}	r _{1,2 min}	s ¹⁾	d _{a min}	D _{a min}	D _{a max}	r _{a max}	r _{b max}
mm						mm				
12	15	24,5	1	0,3	0,5	14	23,5	24,5	1	0,3
15	18	27	1	0,3	0,5	17	26	27	1	0,3
17	20	30,5	1	0,3	0,5	19	29,5	30,5	1	0,3
20	25	36,5	1	0,3	0,5	22	35	37	1	0,3
22	28	38,5	1	0,3	0,5	24	37,5	39	1	0,3
25	30	42	1	0,3	0,5	25	41	42	1	0,3
30	35	47,5	1	0,3	0,5	32	46,5	47,5	1	0,3
35	40	50,5	1	0,3	0,5	37	49,5	50,5	1	0,3
40	45	58	1	0,3	0,5	42	57	58	1	0,3

¹⁾ Permissible axial displacement from normal position of one bearing ring in relation to the other



Needle roller thrust bearings

Product tables page 124

SKF needle roller thrust bearings can support heavy axial loads, are insensitive to shock loads and provide stiff bearing arrangements which require a minimum of axial space. They are single direction bearings and can only accommodate axial loads acting in one direction. Particularly compact bearing arrangements can be made, taking up no more space than a conventional thrust washer, if the faces of adjacent machine components can serve as raceways for a needle roller and cage thrust assembly. For applications where adjacent components cannot serve as raceways, the assemblies can also be combined with washers of various designs.

Because of all the possible combinations, all bearing components must be ordered separately.

Needle roller and cage thrust assemblies

Needle roller and cage thrust assemblies (→ fig 1) consist of a form-stable cage which reliably guides and retains a large number of needle rollers. The needle rollers of one assembly have only very slight diameter deviations; the cylindrical surface of the rollers is slightly relieved towards the ends, thus ensuring an even load distribution and preventing damaging edge loads from occurring.

3

Fig 1

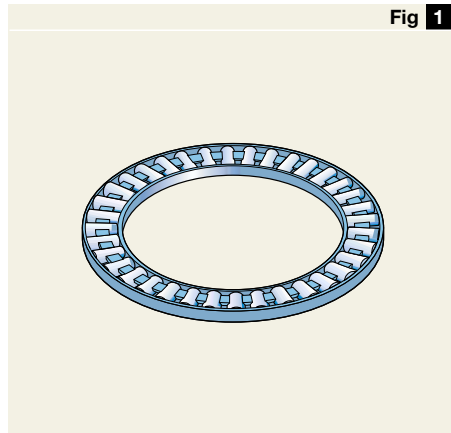

Needle roller thrust bearings

Bearing washers

Raceway washers, series LS

Raceway washers of the LS series (→ **fig 2**) are made of carbon chromium (rolling bearing) steel and are hardened. The raceways are ground and the bore and outside diameter are turned. They may be used both as shaft and as housing washers for bearing arrangements where accurate centring of the washers is not needed or where low speeds are involved.

Thrust washers, series AS

Thrust washers of the AS series (→ **fig 3**) are only 1 mm thick and are made of spring steel. The washers are hardened and polished. They enable very economic bearing arrangements to be produced in cases, where the adjacent machine components are not suitable as raceways, but do have adequate stiffness, and running accuracy requirements are only moderate. The thrust washers can be used both as shaft and as housing washers.

Bearing washers, series WS 811 and GS 811

In addition to the above mentioned LS raceway washers and AS thrust washers, needle roller and cage thrust assemblies can also be combined with the WS shaft washers and GS housing washers (→ **fig 4**) of cylindrical roller thrust bearings of series 811. The use of these shaft and housing washers is recommended, for example, for operation 1 at high speeds when accurate centring of the bearing washers is required. The dimensions and designations of these washers are included in the product tables.

Fig 2

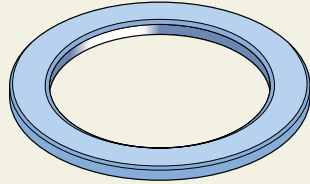

Fig 3

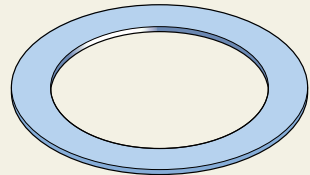
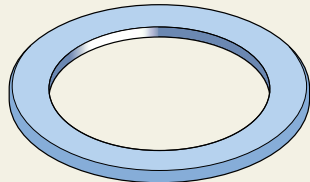

Fig 4



Double direction bearings

By combining intermediate washers, needle roller and cage assemblies of series AXK and the bearing washers (already described) it is possible to assemble double direction needle roller thrust bearings with internal centring (→ **fig 5**) or with external centring (→ **fig 6**).

The intermediate washers must have the same surface finish and hardness as the bearing washers (→ “Design of associated components”, **page 122**). Recommendations regarding suitable dimensions for the intermediate washers will be supplied on request.

Dimensions

The dimensions of the needle roller and cage thrust assemblies correspond to ISO 3031-1979. The dimensions of the AS thrust washers follow the same standard.

The bore and outside diameters of the other bearing washers are in accordance with ISO 104:1994, for thrust bearings of Diameter Series 1.

Fig 5

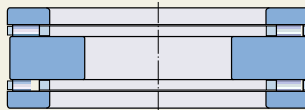
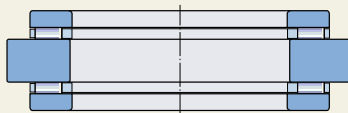

Fig 6



Needle roller thrust bearings

Tolerances

The needle roller and cage thrust assemblies and all the bearings washers are produced to the tolerances listed in **Table 1**. The values for the Normal tolerances to ISO 199:1997 are given in **Table 5**, **page 20**, and the grades of the needle rollers in **Table 1**, **page 211**. The values for the dimension deviations of the various ISO tolerance grades are given in **Table 2**.

Misalignment

Needle roller thrust bearings cannot tolerate any angular misalignment between shaft and housing, nor any errors of alignment between the support surfaces in the housing and on the shaft.

Table 1

Tolerances for needle roller thrust bearings		
Bearing component	Tolerance	
Dimensions		
Needle roller and cage thrust assemblies, AXK		
Bore diameter	d	E12
Outside diameter	D	c13
Roller diameter	D _w	G2, ISO 6193-1980
Raceway washers, LS		
Bore diameter	d	E12
Outside diameter	D	a12
Thickness	B	h11
Axial runout	s _i	Normal, ISO 199
Thrust washers, AS		
Bore diameter	d	E13
Outside diameter	D	e13
Thickness	B ₁	±0,05 mm
Shaft washers, WS 811		
Bore diameter	d	Normal, ISO 199
Outside diameter	d ₁	-
Thickness	B	h11
Axial runout	s _i	Normal, ISO 199
Housing washer, GS 811		
Outside diameter	D	Normal, ISO 199
Bore diameter	D ₁	-
Thickness	B	h11
Axial runout	s _e	Normal, ISO 199

Table 2

ISO tolerances																		
Nominal dimension over incl.	a12	Deviations		c13	Deviations		e13	Deviations		h11	Deviations		E12	Deviations		E13	Deviations	
		high	low		high	low		high	low		high	low		high	low		high	low
mm	µm			µm			µm			µm			µm			µm		
3	6	-270	-390	-70	-250	-20	-200	0	-75	+140	+20	+200	+20					
6	10	-280	-430	-80	-300	-25	-245	0	-90	+175	+25	+245	+25					
10	18	-290	-470	-95	-365	-32	-302	0	-110	+212	+32	+302	+32					
18	30	-300	-510	-110	-440	-40	-370	0	-130	+250	+40	+370	+40					
30	40	-310	-560	-120	-510	-50	-440	0	-160	+300	+50	+440	+50					
40	50	-320	-570	-130	-520	-50	-440	0	-160	+300	+50	+440	+50					
50	65	-340	-640	-140	-600	-60	-520	0	-190	+360	+60	+520	+60					
65	80	-360	-660	-150	-610	-60	-520	0	-190	+360	+60	+520	+60					
80	100	-380	-730	-170	-710	-72	-612	0	-220	+422	+72	+612	+72					
100	120	-410	-760	-180	-720	-72	-612	0	-220	+422	+72	+612	+72					
120	140	-460	-860	-200	-830	-85	-715	0	-250	+485	+85	+715	+85					
140	160	-520	-920	-210	-840	-85	-715	0	-250	+485	+85	+715	+85					
160	180	-580	-980	-230	-860	-85	-715	0	-250	+485	+85	+715	+85					
180	200	-660	-1 120	-240	-960	-100	-820	0	-290	+560	+100	+820	+100					

Cages

SKF needle roller and cage thrust assemblies incorporate a form-stable cage of steel (→ **fig 7**) or sheet steel (→ **fig 8**) as standard, with the exception of those assemblies identified by the designation suffix TN which have an injection moulded cage of glass fibre reinforced polyamide 6,6 (→ **fig 9**).

NB.

Needle roller and cage thrust assemblies with polyamide 6,6 cages can be used at temperatures up to +120 °C. With the exception of a few synthetic oils and greases with a synthetic base oil, and lubricants containing a high proportion of EP additives when used at high temperatures, the lubricants generally used for rolling bearings do not have a detrimental effect on cage properties.

For further information regarding the temperature resistance and use of cages, please refer to the section “Cages” (→ **page 22**).

For bearing arrangements which are to be operated at continuously high temperatures or under arduous conditions, it is recommended that assemblies incorporating steel or sheet steel cages be used.

Fig 7



Fig 8



Fig 9



Design of associated components

The support surfaces in the housing and on the shaft must be at right angles to the shaft axis and should provide uninterrupted support for the bearing washers across the whole extent and width of the raceways. When thrust washers of series AS are used, the dimensions E_a and E_b (given in the product tables) should be applied.

Suitable tolerances for shafts and housings which are known to provide satisfactory radial guidance for the individual thrust bearing components will be found in **Table 3**.

Needle roller and cage thrust assemblies are generally guided radially on the shaft in order to obtain the lowest possible sliding speed against the guiding surfaces. At high speeds radial guidance must be provided on the shaft and the guiding surface must be ground.

Raceways on the shaft and in the housing

Raceways on the shaft and in the housing should have the same hardness and surface finish as normally used for bearing raceways, if the load carrying capacity of the needle roller and cage thrust assemblies is to be fully exploited. Details regarding suitable materials as well as surface hardness and surface finish will be found in the section "Raceways on shafts and in housings" (→ **page 28**). The raceways machined on the shaft and in the housing should have the same axial runout as are normal for shaft and housing washers. The values for the permissible axial runout for shaft and housing washers of thrust bearings are given in (→ **Table 5** on **page 20**).

Table 3

Shaft and housing tolerances			
Bearing component		Shaft tolerance Internal guidance/ centring	Housing tolerance External guidance/ centring
Needle roller and cage thrust assemblies	AXK	h8	–
Raceway washers	LS	h8 –	– H9
Thrust washers	AS	h8 –	– H9
Shaft washers	WS 811	h8	–
Housing washers	GS 811	–	H9

Minimum load

In order to guarantee satisfactory performance, needle roller thrust bearings, like all ball and roller bearings, must always be subjected to a given minimum load, particularly if they are to operate at high speeds or are subjected to high accelerations or rapid changes in the direction of load. Under such conditions the inertia forces of the needle rollers and cage, and the friction in the lubricant, can have a detrimental effect on the rolling conditions in the bearing arrangement and may cause damaging sliding movements to occur between the rollers and raceways.

The requisite minimum axial load to be applied to needle roller thrust bearings can be estimated using

$$F_{am} = 0,0005 C_0$$

where

F_{am} = minimum axial load, N

C_0 = basic static load rating, N

When starting up at low temperatures or when the lubricant is highly viscous, even greater loads may be required. The weights of the components supported by the bearings, together with the external forces, generally exceed the requisite minimum load. If this is not the case, the needle roller thrust bearing must be preloaded (e.g. by springs).

Equivalent dynamic bearing load

For needle roller thrust bearings

$$P = F_a$$

Equivalent static bearing load

For needle roller thrust bearings

$$P_0 = F_a$$

Needle roller thrust bearings d 4 – 80 mm

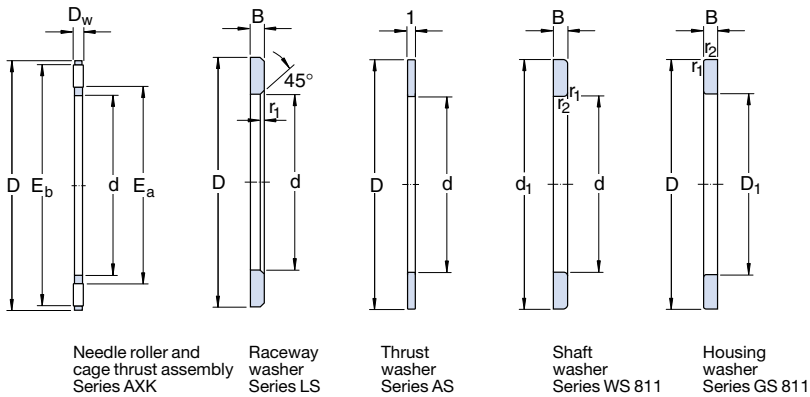

Principal dimensions Needle roller and cage thrust assembly					Basic load ratings dynamic static		Fatigue load limit P_u	Speed ratings Lubrication grease oil		Mass Needle roller and cage thrust assembly	Designation Needle roller and cage thrust assembly
d	D	D_w	E_a	E_b	C	C_0					
mm					N		N	r/min		g	-
4	14	2	5	13	4 150	8 300	865	5 600	7 500	0,7	AXK 0414 TN
5	15	2	6	14	4 500	9 500	1 000	5 000	6 700	0,8	AXK 0515 TN
6	19	2	7	18	6 300	16 000	1 750	4 500	6 000	1	AXK 0619 TN
8	21	2	9	20	7 200	20 000	2 200	4 300	5 600	2	AXK 0821 TN
10	24	2	12	23	8 500	26 000	2 850	3 600	4 800	3	AXK 1024
12	26	2	14	20	9 150	30 000	3 250	3 400	4 500	3	AXK 1226
15	28	2	17	27	10 400	37 500	4 150	3 200	4 300	4	AXK 1528
17	30	2	19	29	11 000	40 500	4 500	3 200	4 300	4	AXK 1730
20	35	2	22	34	12 000	47 500	5 300	2 800	3 800	5	AXK 2035
25	42	2	29	41	13 400	60 000	6 700	2 200	3 200	7	AXK 2542
30	47	2	34	46	15 000	72 000	8 000	2 000	3 000	8	AXK 3047
35	52	2	39	51	16 600	83 000	9 300	1 900	2 800	10	AXK 3552
40	60	3	45	58	25 000	114 000	13 700	1 700	2 400	16	AXK 4060
45	65	3	50	63	27 000	127 000	15 300	1 600	2 200	18	AXK 4565
50	70	3	55	68	28 500	143 000	17 000	1 600	2 200	20	AXK 5070
55	78	3	60	76	34 500	186 000	22 400	1 400	1 900	28	AXK 5578
60	85	3	65	83	37 500	232 000	28 500	1 300	1 800	33	AXK 6085
65	90	3	70	88	39 000	255 000	31 000	1 200	1 700	35	AXK 6590
70	95	4	74	93	49 000	255 000	30 500	1 200	1 700	60	AXK 7095
75	100	4	79	98	50 000	265 000	32 000	1 100	1 600	61	AXK 75100
80	105	4	84	103	51 000	280 000	33 500	1 000	1 500	63	AXK 80105

Dimensions Washers						Masses Washers LS, WS, GS AS		Designations Raceway washer Thrust washer		Shaft washer	Housing washer
d	d ₁	D	D ₁	B	r _{1,2} min						
mm						g		-			
4	-	14	-	-	-	-	1	-	AS 0414	-	-
5	-	15	-	-	-	-	1	-	AS 0515	-	-
6	-	19	-	2,75	0,3	4	2	LS 0619 AS 0619	-	-	
8	-	21	-	2,75	0,3	4	2	LS 0821 AS 0821	-	-	
10	-	24	-	2,75	0,3	7	3	LS 1024 AS 1024	-	-	
12	-	26	-	2,75	0,3	8	3	LS 1226 AS 1226	-	-	
15	28	28	16	2,75	0,3	9	3	LS 1528 AS 1528	WS 81102	GS 81102	
17	30	30	18	2,75	0,3	9	4	LS 1730 AS 1730	WS 81103	GS 81103	
20	35	35	21	2,75	0,3	13	5	LS 2035 AS 2035	WS 81104	GS 81104	
25	42	42	26	3	0,6	19	7	LS 2542 AS 2542	WS 81105	GS 81105	
30	47	47	32	3	0,6	22	8	LS 3047 AS 3047	WS 81106	GS 81106	
35	52	52	37	3,5	0,6	29	9	LS 3552 AS 3552	WS 81107	GS 81107	
40	60	60	42	3,5	0,6	40	12	LS 4060 AS 4060	WS 81108	GS 81108	
45	65	65	47	4	0,6	50	13	LS 4565 AS 4565	WS 81109	GS 81109	
50	70	70	52	4	0,6	55	14	LS 5070 AS 5070	WS 81110	GS 81110	
55	78	78	57	5	0,6	88	18	LS 5578 AS 5578	WS 81111	GS 81111	
60	85	85	62	4,75	1	97	22	LS 6085 AS 6085	WS 81112	GS 81112	
65	90	90	67	5,25	1	115	24	LS 6590 AS 6590	WS 81113	GS 81113	
70	95	95	72	5,25	1	125	25	LS 7095 AS 7095	WS 81114	GS 81114	
75	100	100	77	5,75	1	140	27	LS 75100 AS 75100	WS 81115	GS 81115	
80	105	105	82	5,75	1	150	28	LS 80105 AS 80105	WS 81116	GS 81116	

Needle roller thrust bearings

d 85 – 160 mm

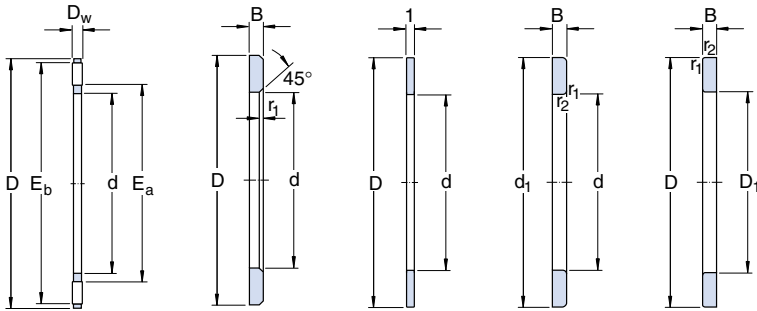

Needle roller and cage thrust assembly Series AXK

Raceway washer Series LS

Thrust washer Series AS

Shaft washer Series WS 811

Housing washer Series GS 811

Principal dimensions Needle roller and cage thrust assembly	Principal dimensions				Basic load ratings		Fatigue load limit P_u	Speed ratings		Mass Needle roller and cage thrust assembly	Designation Needle roller and cage thrust assembly
	d	D	D_w	E_a	E_b	C		C_0	Lubrication		
mm						N		N	r/min	g	-
85	110	4	89	108	52 000	290 000	34 500	1 000	1 500	67	AXK 85110
90	120	4	94	118	65 500	405 000	48 000	900	1 300	86	AXK 90120
100	135	4	105	133	76 500	560 000	65 500	850	1 200	105	AXK 100135
110	145	4	115	143	81 500	620 000	71 000	800	1 100	120	AXK 110145
120	155	4	125	153	86 500	680 000	76 500	800	1 100	130	AXK 120155
130	170	5	136	167	112 000	830 000	93 000	700	950	205	AXK 130170
140	180	5	146	177	116 000	900 000	98 600	670	900	220	AXK 140180
150	190	5	156	187	120 000	950 000	102 000	630	850	230	AXK 150190
160	200	5	166	197	125 000	1 000 000	106 000	630	850	245	AXK 160200

Dimensions Washers						Masses Washers LS, AS WS, GS		Designations Raceway washer Thrust washer Shaft washer Housing washer			
d	d ₁	D	D ₁	B	r _{1,2} min						
mm						g		-			
85	110	110	87	5,75	1	160	29	LS 85110	AS 85110	WS 81117	GS 81117
90	120	120	92	6,5	1	235	39	LS 90120	AS 90120	WS 81118	GS 81118
100	135	135	102	7	1	350	50	LS 100135	AS 100135	WS 81120	GS 81120
110	145	145	112	7	1	385	55	LS 110145	AS 110145	WS 81122	GS 81122
120	145	155	122	7	1	415	59	LS 120155	AS 120155	WS 81124	GS 81124
130	170	170	132	9	1	665	65	LS 130170	AS 130170	WS 81126	GS 81126
140	178	180	142	9,5	1	750	79	LS 140180	AS 140180	WS 81128	GS 81128
150	188	190	152	9,5	1	795	84	LS 150190	AS 150190	WS 81130	GS 81130
160	198	200	162	9,5	1	840	89	LS 160200	AS 160200	WS 81132	GS 81132



Combined needle roller bearings

Needle roller/angular contact ball bearings	page 130
Needle roller/thrust ball bearings	page 138
Needle roller/cylindrical roller thrust bearings	page 150

Combined needle roller bearings consist of a radial needle roller bearing combined with a thrust bearing and are consequently able to take up both radial and axial loads. Combined needle roller bearings provide the means to produce locating bearing arrangements in a minimum of radial space. They are particularly useful where the axial loads are too heavy, speeds too high, or lubrication inadequate for simple thrust washers to be suitable, and other types of locating bearing take up too much room.

SKF combined needle roller bearings are available in the following designs:

- **needle roller/angular contact ball bearings**
- **needle roller/thrust ball bearings**
- **needle roller/cylindrical roller thrust bearings**



Needle roller/angular contact ball bearings

Product tables page 134

Needle roller/angular contact ball bearings combine a radial needle roller bearing with a radial angular contact ball bearing to produce a very low-section bearing which can operate at high speeds and which can carry heavy radial and light axial loads. The radial loads are accommodated exclusively by the needle roller bearings. The axial loads acting on the angular contact ball bearing should not exceed 25 % of the simultaneously acting radial load.

To ensure efficient lubrication, the needle roller bearing has an annular groove and lubrication hole in the outer ring.

Design

SKF needle roller/angular contact ball bearings of series NKIA 59 (→ fig 1) can accommodate axial loads acting in one direction and can thus provide location for a shaft in one direction. They are of separable design, i.e. the inner ring can be mounted separately

from the outer ring with rolling element and cage assemblies.

Bearings of series NKIB 59 (→ fig 2) are able to locate a shaft in both directions with an axial play of 0,08 to 0,25 mm. For easy mounting, the inner ring is in two parts. When mounting the inner ring it is important to ensure that the two parts are mounted immediately adjacent to each other with zero axial clearance. The two parts are not interchangeable with the inner rings of other bearings.

For the support of short shafts, where alterations in length caused by thermal changes do not occur in operation, two bearings of series NKIA 59 can be used in a face-to-face or back-to-back arrangement (→ fig 3).

Fig 1

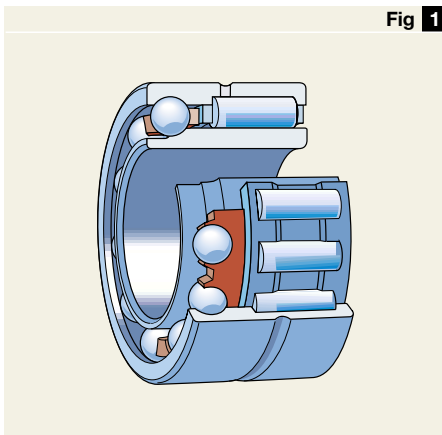
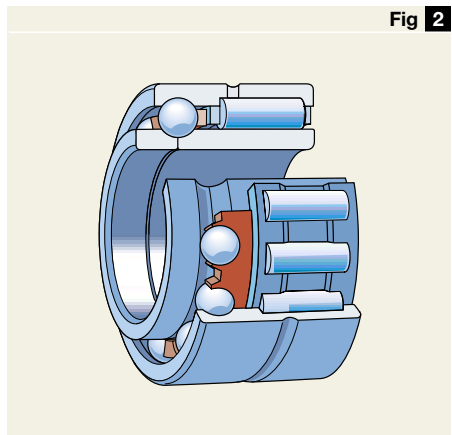

Fig 2



Dimensions

The boundary dimensions of bearings of series NKIA 59 are in accordance with Dimension Series 59 of ISO 15:1998. With the exception of the inner ring width, which is extended at one side, this also applies to bearings of series NKIB 59.

Tolerances

SKF needle roller/angular contact ball bearings are produced as standard with Normal tolerances to ISO 492:1994 (→ **Table 2**, **page 17**). The only exceptions to this are the tolerances for the bore of the narrow part of the inner ring of series NKIB 59, which is larger, and for the width of the complete inner ring of series of series NKIB 59 bearings which is a uniform $0/-0,3$ mm for all sizes.

Internal clearance

Needle roller/angular contact ball bearings are produced as standard with Normal internal clearance (→ **Table 6**, **page 21**).

The clearance values conform to ISO 5753:1991. The bearings must be kept together as supplied, i.e. the outer rings with rolling element and cage assemblies, inner rings and inner ring parts are not interchangeable with those of other bearings.

Misalignment

The modified line contact between the needle rollers and raceways of needle roller/angular contact ball bearings enables minimum misalignments of the shaft relative to the housing to be accommodated without imposing heavy additional forces on the angular contact ball bearing.

Fig 3

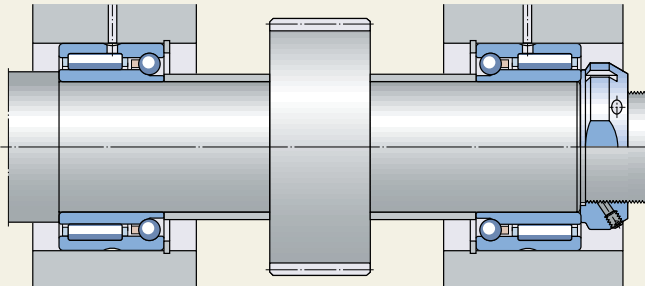

Combined needle roller bearings

Cages

The needle rollers of needle roller/angular contact ball bearings are guided in a steel (→ fig 4) or sheet steel cage (→ fig 5). The balls are retained in an injection moulded snap-type cage of glass fibre reinforced polyamide 6,6 (→ fig 6).

NB.

Needle roller/angular contact ball bearings with polyamide 6,6 cages can be used at temperatures up to +120 °C. With the exception of a few synthetic oils and greases with a synthetic base oil, and lubricants containing a high proportion of EP additives when used at high temperatures, the lubricants generally used for rolling bearings do not have a detrimental effect on cage properties.

For further information regarding the temperature resistance and use of cages, please refer to the section “Cages” (→ page 22).

Shaft and housing tolerances

For needle roller/angular contact ball bearings it is recommended that the shaft seating be machined to tolerance k5 and the housing bore seating to tolerance M6. Tighter fits than those achieved with these tolerances should be avoided as they would have a negative influence on bearing performance.

Fig 4

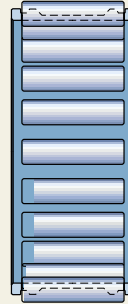

Fig 5



Fig 6



Minimum load

In order to guarantee satisfactory performance, needle roller/angular contact ball bearings, like all ball and roller bearings, must always be subjected to a given minimum load acting in both the radial and axial directions, particularly if they are to operate at high speeds or are subjected to high accelerations or rapid changes in the direction of load. Under such conditions the inertia forces of the rolling elements and cages, and the friction in the lubricant, can have a detrimental influence on the rolling conditions in the bearing arrangement and may cause damaging sliding movements to occur between the rolling elements and raceways.

The requisite minimum radial load to be applied to the radial needle roller bearing can be estimated using

$$F_{rm} = 0,02 C$$

The requisite minimum axial load for the angular contact ball bearing can be obtained from

$$F_{am} = 0,25 \frac{C_0}{1\ 000} \left(\frac{n d_m}{100\ 000} \right)^2$$

where

F_{rm} = minimum radial load, N

F_{am} = minimum axial load, N

C = basic dynamic load rating, N

C_0 = basic static load rating, N

d_m = mean bearing diameter

= $0,5 (d + D)$, mm

n = rotational speed, r/min

When starting up at low temperatures or when the lubricant is highly viscous, even greater loads may be required. The weights of the components supported by the bearing, together with the external forces, generally exceed the requisite minimum loads. If this is not the case, the needle roller/angular contact ball bearing must be subjected to an additional radial and/or axial load.

Equivalent dynamic bearing load

For the radial needle roller bearing

$$P = F_r$$

and for the angular contact ball bearing

$$P = F_a$$

where F_a must not exceed $0,25 F_r$.

Equivalent static bearing load

For the radial needle roller bearing

$$P_0 = F_r$$

and for the angular contact ball bearing

$$P_0 = F_a$$

where F_a must not exceed $0,25 F_r$.

Load carrying capacity and life

It is necessary to calculate the lives of the radial needle roller bearing and the angular contact ball bearing separately for combined needle roller/angular contact ball bearings.

Needle roller/angular contact ball bearings

d 12–60 mm

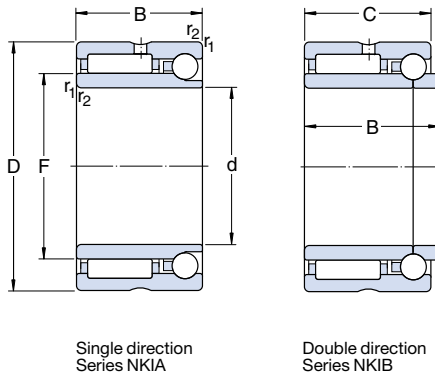

Principal dimensions				Basic load ratings				Fatigue load limits		Speed ratings		Mass	Designation
d	D	B	C	radial dynamic C	static C ₀	axial dynamic C	static C ₀	radial P _u	axial P _u	Lubrication grease	oil		
mm				N				N		r/min		kg	-
12	24	16	-	8 250	10 000	2 070	1 920	1 140	83	15 000	22 000	0,040	NKIA 5901
	24	17,5	16	8 250	10 000	2 070	1 920	1 140	83	15 000	22 000	0,043	NKIB 5901
15	28	18	-	11 400	15 600	2 270	2 370	1 830	99	13 000	19 000	0,050	NKIA 5902
	28	20	18	11 400	15 600	2 270	2 370	1 830	99	13 000	19 000	0,052	NKIB 5902
17	30	18	-	11 700	17 000	2 240	2 740	1 960	116	12 000	18 000	0,056	NKIA 5903
	30	20	18	11 700	17 000	2 240	2 740	1 960	116	12 000	18 000	0,058	NKIB 5903
20	37	23	-	21 600	28 000	3 790	4 210	3 350	176	9 500	15 000	0,10	NKIA 5904
	37	25	23	21 600	28 000	3 790	4 210	3 350	176	9 500	15 000	0,11	NKIB 5904
22	39	23	-	23 300	32 000	4 140	4 930	3 900	205	9 000	14 000	0,12	NKIA 59/22
	39	25	23	23 300	32 000	4 140	4 930	3 900	205	9 000	14 000	0,12	NKIB 59/22
25	42	23	-	24 200	34 500	4 240	5 260	4 150	224	8 500	13 000	0,13	NKIA 5905
	42	25	23	24 200	34 500	4 240	5 260	4 150	224	8 500	13 000	0,13	NKIB 5905
30	47	23	-	25 500	39 000	4 540	6 320	4 650	268	7 500	11 000	0,15	NKIA 5906
	47	25	23	25 500	39 000	4 540	6 320	4 650	268	7 500	11 000	0,15	NKIB 5906
35	55	27	-	31 900	54 000	5 830	8 420	6 700	355	6 700	9 500	0,24	NKIA 5907
	55	30	27	31 900	54 000	5 830	8 420	6 700	355	6 700	9 500	0,25	NKIB 5907
40	62	30	-	42 900	71 000	7 170	10 900	8 800	467	5 600	8 000	0,32	NKIA 5908
	62	34	30	42 900	71 000	7 170	10 900	8 800	467	5 600	8 000	0,32	NKIB 5908
45	68	30	-	45 700	78 000	7 470	12 000	9 650	513	5 300	7 500	0,38	NKIA 5909
	68	34	30	45 700	78 000	7 470	12 000	9 650	513	5 300	7 500	0,38	NKIB 5909
50	72	30	-	47 300	85 000	7 740	13 700	10 600	579	5 000	7 000	0,38	NKIA 5910
	72	34	30	47 300	85 000	7 740	13 700	10 600	579	5 000	7 000	0,39	NKIB 5910
55	80	34	-	57 200	104 000	9 270	16 700	13 200	697	4 500	6 300	0,55	NKIA 5911
	80	38	34	57 200	104 000	9 270	16 700	13 200	697	4 500	6 300	0,56	NKIB 5911
60	85	34	-	59 400	114 000	9 580	18 000	14 300	770	4 300	6 000	0,59	NKIA 5912
	85	38	34	59 400	114 000	9 580	18 000	14 300	770	4 300	6 000	0,60	NKIB 5912

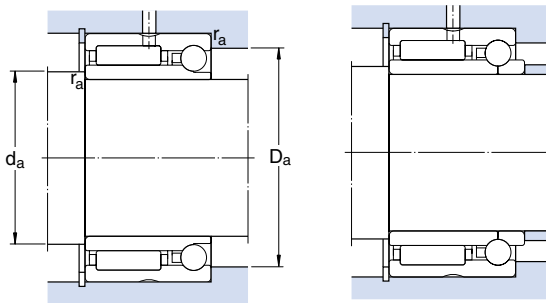

Dimensions

Abutment and fillet dimensions

d	F	$r_{1,2}$ min	d_a min	D_a max	r_a max
mm			mm		
12	16	0,3	14	22	0,3
	16	0,3	14	22	0,3
15	20	0,3	17	26	0,3
	20	0,3	17	26	0,3
17	22	0,3	19	28	0,3
	22	0,3	19	28	0,3
20	25	0,3	22	35	0,3
	25	0,3	22	35	0,3
22	28	0,3	24	37	0,3
	28	0,3	24	37	0,3
25	30	0,3	27	40	0,3
	30	0,3	27	40	0,3
30	35	0,3	32	45	0,3
	35	0,3	32	45	0,3
35	42	0,6	39	51	0,6
	42	0,6	39	51	0,6
40	48	0,6	44	58	0,6
	48	0,6	44	58	0,6
45	52	0,6	49	64	0,6
	52	0,6	49	64	0,6
50	58	0,6	54	68	0,6
	58	0,6	54	68	0,6
55	63	1	60	75	1
	63	1	60	75	1
60	68	1	65	80	1
	68	1	65	80	1



Needle roller/angular contact ball bearings
d 65 – 70 mm

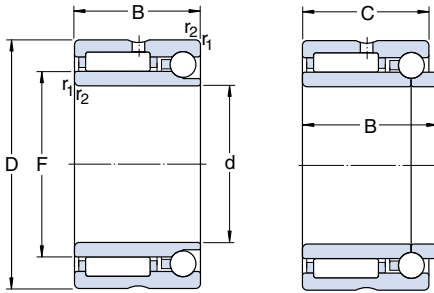

Single direction
Series NKIA

Double direction
Series NKIB

Principal dimensions				Basic load ratings				Fatigue load limits		Speed ratings		Mass	Designation
d	D	B	C	radial dynamic C	static C ₀	axial dynamic C	static C ₀	radial P _u	axial P _u	Lubrication grease oil		kg	-
mm				N				N		r/min		kg	-
65	90	34	-	60 500	118 000	9 960	19 200	14 600	816	4 000	5 600	0,64	NKIA 5913
	90	38	34	60 500	118 000	9 960	19 200	14 600	816	4 000	5 600	0,64	NKIB 5913
70	100	40	-	84 200	163 000	13 200	25 000	20 800	1 050	3 600	5 000	0,98	NKIA 5914
	100	45	40	84 200	163 000	13 200	25 000	20 800	1 050	3 600	5 000	0,99	NKIB 5914

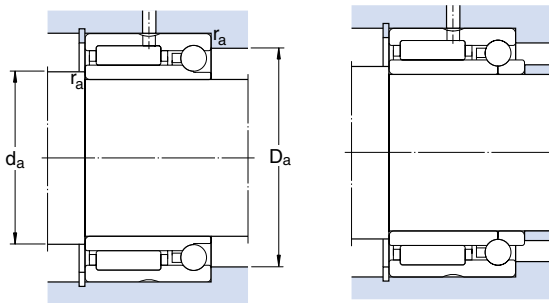

Dimensions

Abutment and fillet dimensions

d	F	$r_{1,2}$ min	d_a min	D_a max	r_a max
mm			mm		
65	72	1	70	85	1
	72	1	70	85	1
70	80	1	75	95	1
	80	1	75	95	1

Needle roller/thrust ball bearings

Product tables

Needle roller/thrust ball bearings, full complement	page 146
Needle roller/thrust ball bearings	page 148

Needle roller/thrust ball bearings are a combination of a radial needle roller bearing and a thrust ball bearing. In series NX the thrust ball bearing is a full complement bearing, i.e. without cage (→ **fig 1**). In series NKX, the thrust ball bearing is of the “normal” caged design (→ **fig 2**).

All SKF needle roller/thrust ball bearings are supplied without inner ring. For applications where it is not possible to harden and grind the shaft, the bearings can be combined with an inner ring (→ **fig 3**). Appropriate inner rings are shown in the product tables.

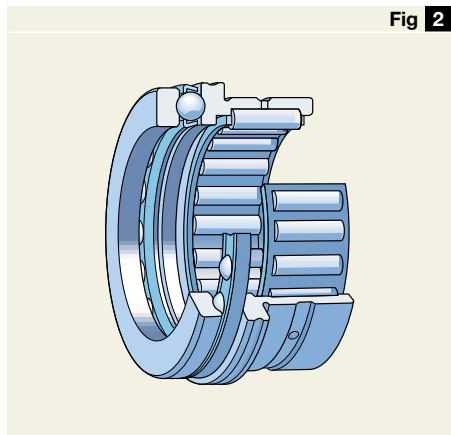
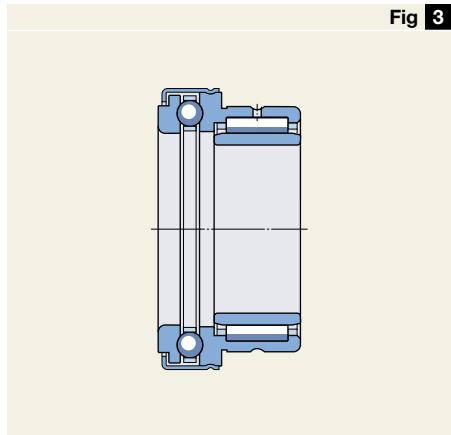
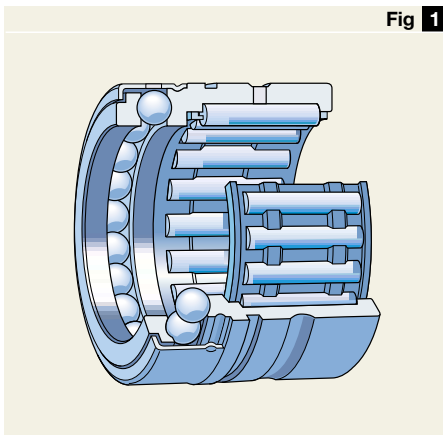

Needle roller/full complement thrust ball bearings, series NX

SKF needle roller/full complement thrust ball bearings of series NX are suitable for the accommodation of moderate radial loads and lighter, single direction axial loads. Their special characteristic is their extremely low sectional height which allows shaft centre-lines to be positioned close together, as for example, in multi-spindle drilling machines.

For axial support, the bearings may be mounted against a shoulder in the housing bore, or against a retaining ring mounted in the housing bore. The use of a snap ring inserted in the snap ring groove in the outer ring provides a particularly economic and axially space-saving arrangement (→ fig 4). The appropriate snap rings are shown in the product table but are not supplied by SKF.

NX needle roller/full complement thrust ball bearings have a pressed steel cover which extends over the shaft washer of the radial needle roller bearing and is firmly attached to the radial needle roller bearing and are therefore non-separable. Bearings of series NX have lubrication holes in the cover (→ fig 5) and are intended for oil lubrication. For grease lubrication, bearings of series NX .. Z (→ fig 6) should be used. These have no lubrication holes in the cover. The cover forms a gap-type seal with the shaft washer.

Fig 4

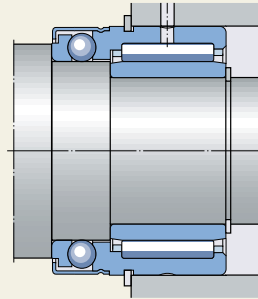

Fig 5

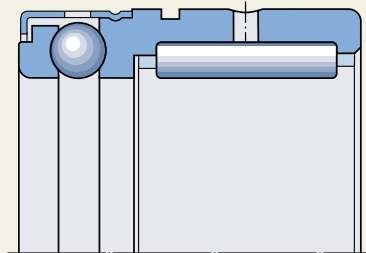
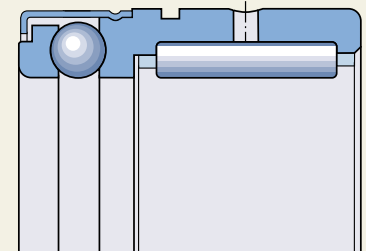

Fig 6



3

Needle roller/thrust ball bearings

Needle roller/thrust ball bearings, series NKX

SKF needle roller/thrust ball bearings of series NKX combine a radial needle roller bearing and a thrust ball bearing of series 511. They are able to support heavy single-direction axial loads in addition to radial loads. They also permit relatively high speed operation.

NKX needle roller/thrust ball bearings (→ **fig 7**) are of separable design. The needle roller and cage assembly with outer ring and integral housing washer, the ball and cage thrust assembly and the shaft washer can all be mounted individually. The non-separable bearings of series NKX .. Z have a cover attached to the housing washer (integral with the needle roller bearing outer ring) which extends over the shaft washer and holds the bearing together (→ **fig 8**). The cover forms a gap-type seal with the shaft washer. Bearings of this series are particularly suitable for grease lubrication as the cover retains the grease in the bearing and prevents it from being expelled by the ball and cage assembly. The separable bearings of series NKX should be lubricated with oil where possible as oil makes it easier to ensure an adequate supply of lubricant to the bearing.

Fig 7

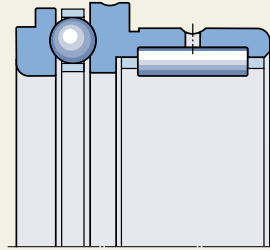
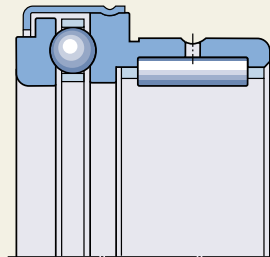

Fig 8



Dimensions

The boundary dimensions of needle roller/thrust ball bearings of series NKX conform to DIN 5429, Part 1, 1987. The dimensions of series NX bearings are not standardised but have been generally accepted by industry.

Tolerances

SKF needle roller/thrust ball bearings are supplied having the tolerances shown in **Table 1**. The radial runout corresponds to the values given in ISO 492:1994 and the axial runout to ISO 199:1997 for normal tolerances (→ **Tables 2** and **5**, **pages 17** and **20**).

The values for the deviations from the nominal dimensions of the ISO tolerance grades quoted in **Table 1** are given in **Table 2**.

Internal clearance

It is recommended that the shaft seating be machined to tolerance k5 and the housing bore seating to tolerance K6. For stiff bearing arrangements, housing bore tolerance M6 has been found appropriate. If separate inner rings are used, a shaft seating tolerance of k5 is again suitable.

These tolerances will give a suitable internal clearance for the bearing which is somewhat smaller than the Normal radial internal clearance specified in ISO 5753:1991.

Misalignment

Needle roller/thrust ball bearings cannot accept any angular misalignment of the shaft with respect to the housing, nor any errors of angle between the support surfaces on the shaft or in the housing.

Table 1

Needle roller/thrust ball bearing tolerances		
Dimension	Tolerance	
Outside diameter	D	Normal, ISO 492:1994
Inside diameter of needle roller complement	F _w	F6
Bore diameter	d	E8
Width	C	0/−0,25 mm
Width	C ₁	0/−0,20 mm

Table 2

ISO tolerances					
Nominal dimension over incl.		E8 Deviations high low		F6 Deviations high low	
mm		µm		µm	
6	10	+47	+25	+22	+13
10	18	+59	+32	+27	+16
18	30	+73	+40	+33	+20
30	50	+89	+50	+41	+25
50	80	+106	+60	+49	+30

Fig 9

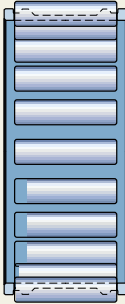

Cages

The needle rollers of SKF needle roller/thrust ball bearings are guided in a cage of steel (→ fig 9), or sheet steel (→ fig 10), except in bearings identified by the designation suffix TN where a glass fibre reinforced polyamide 6,6 cage is used (→ fig 11). The cage which retains the balls of the thrust ball bearing is made of pressed steel (→ fig 12).

NB.

Needle roller/thrust ball bearings with polyamide 6,6 cages can be used at temperatures up to +120 °C. With the exception of a few synthetic oils and greases with a synthetic base oil, and lubricants containing a high proportion of EP additives when used at high temperatures, the lubricants generally used for rolling bearings do not have a detrimental effect on cage properties.

For further information regarding the temperature resistance and use of cages, please refer to the section “Cages” (→ page 22).

Fig 10

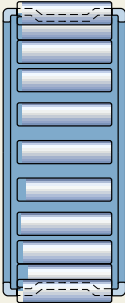

Fig 11

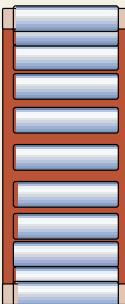

Fig 12



Fig 13

Design of associated components

The diameter of the support surface for the integral housing washer of needle roller/thrust ball bearings must always be at least 0,5 mm larger than the dimension D_1 or D_2 (→ fig 13) in order to ensure a clearance fit.

Raceways on the shaft

If the load carrying capacity of the radial needle roller bearing is to be fully exploited then the hardness and surface finish of the raceway machined on the shaft should be the same as those of inner ring raceways. Details of suitable materials, hardness and surface finish will be found in the section “Raceways on shafts and in housings” (→ page 28).

Application recommendations

SKF needle roller/thrust ball bearings can axially locate a shaft in one direction. Short shafts, where there is no risk of changes in length occurring in practice as a result of thermal changes, may be supported in two bearings arranged either face-to-face or back-to-back (→ fig 14). In such cases it is recommended that the thrust ball bearings be elastically preloaded, e.g. by cup springs. This elastic preload serves to ensure proper and quiet performance of the thrust ball bearing without any slip when it is unloaded.

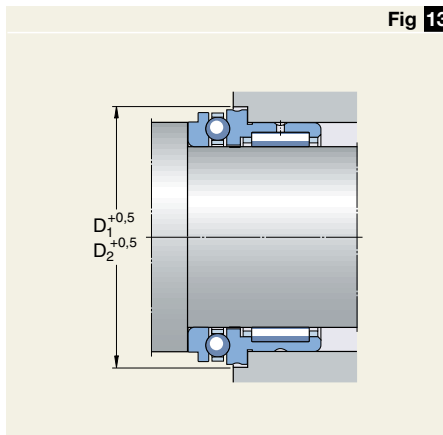

3

Fig 14



Needle roller/thrust ball bearings

Minimum load

In order to guarantee satisfactory operation, needle roller/thrust ball bearings, like all ball and roller bearings, must always be subjected to a given minimum load acting in both the radial and axial directions, particularly if they are to operate at high speeds or are subjected to high accelerations or rapid changes in the direction of load. Under such conditions the inertia forces of the rolling elements and cages, and the friction in the lubricant, can have a detrimental influence on the rolling conditions in the bearing arrangement and may cause damaging sliding movements to occur between the rolling elements and raceways.

The requisite minimum radial load to be applied to the radial needle roller bearing can be estimated using

$$F_{rm} = 0,02 C$$

The requisite minimum axial load for the thrust ball bearing can be obtained from

$$F_{am} = A \left(\frac{n}{1\,000} \right)^2$$

where

F_{rm} = minimum radial load, N

F_{am} = minimum axial load, N

A = minimum load factor, see product tables

C = basic dynamic load rating, N

n = rotational speed, r/min

When starting up at low temperatures or when the lubricant is highly viscous, even greater loads may be required. The weights of the components supported by the bearing, together with the external forces, generally exceed the requisite minimum loads. If this is not the case, the needle roller/thrust ball bearing must be subjected to an additional radial and/or axial load.

Equivalent dynamic bearing load

For the radial needle roller bearing

$$P = F_r$$

and for the thrust ball bearing

$$P = F_a$$

Equivalent static bearing load

For the radial needle roller bearing

$$P_0 = F_r$$

and for the thrust ball bearing

$$P_0 = F_a$$

Load carrying capacity and life

It is necessary to calculate the life of the radial needle roller bearing and of the thrust ball bearing separately for needle roller/thrust ball bearings.

Needle roller/thrust ball bearings, full complement

F_w 7 – 35 mm

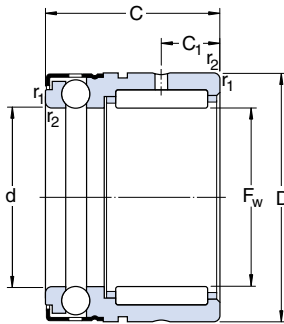

For oil lubrication
Series NX

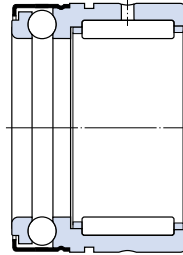

For grease lubrication
Series NX..Z

Principal dimensions			Basic load ratings				Fatigue load limits		Min. load factor A	Speed ratings		Mass kg	Designation
F_w	D	C	radial dynamic C	static C_0	axial dynamic C	static C_0	radial P_u	axial P_u		Lubrication grease	oil		
mm			N				N		–	r/min			–
7	14	18	2 810	2 750	3 450	5 000	290	186	0,13	–	10 000	0,014	NX 7 TN¹⁾
	14	18	2 810	2 750	3 450	5 000	290	186	0,13	7 500	–	0,014	NX 7 ZTN¹⁾
10	19	18	4 680	4 150	5 070	8 500	475	310	0,38	–	8 500	0,025	NX 10
	19	18	4 680	4 150	5 070	8 500	475	310	0,38	6 300	–	0,025	NX 10 Z
12	21	18	5 500	5 400	5 270	9 650	610	355	0,48	–	8 000	0,028	NX 12
	21	18	5 500	5 400	5 270	9 650	610	355	0,48	6 000	–	0,028	NX 12 Z
15	24	28	11 200	14 000	6 180	12 200	1 660	450	0,77	–	7 500	0,048	NX 15
	24	28	11 200	14 000	6 180	12 200	1 660	450	0,77	5 600	–	0,048	NX 15 Z
17	26	28	12 300	16 600	6 370	13 400	1 960	500	0,93	–	7 000	0,053	NX 17
	26	28	12 300	16 600	6 370	13 400	1 960	500	0,93	5 300	–	0,053	NX 17 Z
20	30	28	13 400	19 600	7 800	17 300	2 280	640	1,6	–	6 300	0,068	NX 20
	30	28	13 400	19 600	7 800	17 300	2 280	640	1,6	4 800	–	0,068	NX 20 Z
25	37	30	15 400	25 000	12 400	28 500	2 900	1 060	4,2	–	5 600	0,12	NX 25
	37	30	15 400	25 000	12 400	28 500	2 900	1 060	4,2	4 300	–	0,12	NX 25 Z
30	42	30	22 900	39 000	12 700	32 500	4 800	1 200	5,5	–	5 300	0,13	NX 30
	42	30	22 900	39 000	12 700	32 500	4 800	1 200	5,5	4 000	–	0,13	NX 30 Z
35	47	30	24 600	45 000	13 500	38 000	5 600	1 400	7,5	–	5 000	0,16	NX 35
	47	30	24 600	45 000	13 500	38 000	5 600	1 400	7,5	3 800	–	0,16	NX 35 Z

¹⁾ Bearing with closure ring insert

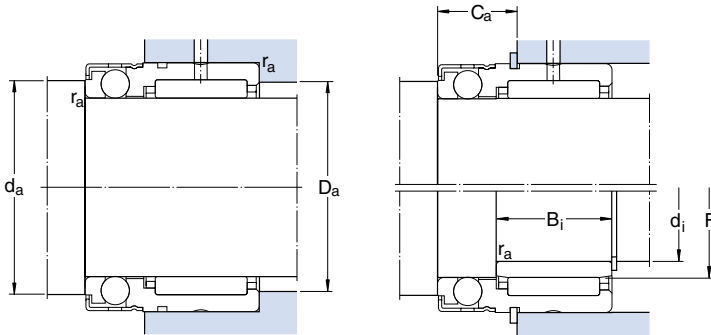

Dimensions			Abutment and fillet dimensions					Appropriate inner ring ¹⁾ Dimensions			Designation	Appropriate retaining ring ²⁾ Designation
F _w	C ₁	d	r _{1,2} min	d _a	D _a max	C _a	r _a max	d _i	F	B _i		
mm			mm					mm			-	-
7	4,7	7	0,3	9,5	12	10	0,3	-	-	-	-	SW 14
	4,7	7	0,3	9,5	12	10	0,3	-	-	-	-	SW 14
10	4,7	10	0,3	14,5	17	10	0,3	6	10	10	IR 6×10×10	SW 19
	4,7	10	0,3	14,5	17	10	0,3	6	10	10	IR 6×10×10	SW 19
12	4,7	12	0,3	16,5	19	10	0,3	8	12	10	IR 8×12×10	SW 21
	4,7	12	0,3	16,5	19	10	0,3	8	12	10	IR 8×12×10	SW 21
15	8	15	0,3	19	22	12,2	0,3	12	15	16	IR 12×15×16	SW 24
	8	15	0,3	19	22	12,2	0,3	12	15	16	IR 12×15×16	SW 24
17	8	17	0,3	21	24	12,2	0,3	14	17	17	IR 14×17×17	SW 26
	8	17	0,3	21	24	12,2	0,3	14	17	17	IR 14×17×17	SW 26
20	8	20	0,3	25	28	12,2	0,3	17	20	16	IR 17×20×16	SW 30
	8	20	0,3	25	28	12,2	0,3	17	20	16	IR 17×20×16	SW 30
25	8	25	0,3	31,5	35	14,2	0,3	20	25	16	IR 20×25×16	SW 37
	8	25	0,3	31,5	35	14,2	0,3	20	25	16	IR 20×25×16	SW 37
30	10	30	0,3	36,5	40	14,2	0,3	25	30	20	IR 25×30×20	SW 42
	10	30	0,3	36,5	40	14,2	0,3	25	30	20	IR 25×30×20	SW 42
35	10	35	0,3	40,5	45	14,2	0,3	30	35	20	IR 30×35×20	SW 47
	10	35	0,3	40,5	45	14,2	0,3	30	35	20	IR 30×35×20	SW 47

¹⁾ Details of appropriate inner rings will be found in the section "Inner rings" (→ page 204)

²⁾ To DIN 471; not supplied by SKF



Needle roller/thrust ball bearings

F_w 10 – 70 mm

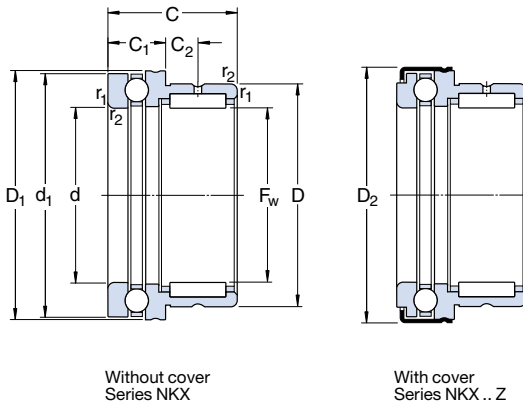

Principal dimensions			Basic load ratings				Fatigue load limits		Min. load factor A	Speed ratings		Mass kg	Designation
F _w	D	C	radial C	dynamic static C ₀	axial dynamic C	axial static C ₀	radial P _u	axial P _u		Lubrication	grease oil		
mm			N				N		-	r/min		-	-
10	19	23	5 940	8 000	9 950	15 300	900	560	1,2	7 000	9 500	0,034	NKX 10 TN ¹⁾
	19	23	5 940	8 000	9 950	15 300	900	560	1,2	7 000	9 500	0,036	NKX 10 ZTN ¹⁾
12	21	23	6 160	8 650	10 400	16 600	980	620	1,4	6 700	9 000	0,038	NKX 12
	21	23	6 160	8 650	10 400	16 600	980	620	1,4	6 700	9 000	0,040	NKX 12 Z
15	24	23	11 200	14 000	10 600	18 300	1 660	670	1,7	6 300	8 500	0,044	NKX 15
	24	23	11 200	14 000	10 600	18 300	1 660	670	1,7	6 300	8 500	0,047	NKX 15 Z
17	26	25	12 300	16 600	10 800	19 600	1 960	735	2,0	6 300	8 500	0,053	NKX 17
	26	25	12 300	16 600	10 800	19 600	1 960	735	2,0	6 300	8 500	0,055	NKX 17 Z
20	30	30	16 800	26 000	14 300	27 000	3 050	1 000	3,8	5 600	7 500	0,083	NKX 20
	30	30	16 800	26 000	14 300	27 000	3 050	1 000	3,8	5 600	7 500	0,090	NKX 20 Z
25	37	30	19 000	32 500	19 500	40 500	4 000	1 500	8,5	4 800	6 300	0,13	NKX 25
	37	30	19 000	32 500	19 500	40 500	4 000	1 500	8,5	4 800	6 300	0,13	NKX 25 Z
30	42	30	22 900	39 000	20 300	45 500	4 800	1 700	10	4 500	6 000	0,14	NKX 30
	42	30	22 900	39 000	20 300	45 500	4 800	1 700	10	4 500	6 000	0,15	NKX 30 Z
35	47	30	24 600	45 000	21 200	51 000	5 600	1 900	13	4 300	5 600	0,16	NKX 35
	47	30	24 600	45 000	21 200	51 000	5 600	1 900	13	4 300	5 600	0,17	NKX 35 Z
40	52	32	26 400	51 000	27 000	68 000	6 300	2 550	24	3 800	5 000	0,20	NKX 40
	52	32	26 400	51 000	27 000	68 000	6 300	2 550	24	3 800	5 000	0,21	NKX 40 Z
45	58	32	28 100	57 000	28 100	75 000	7 100	2 800	29	3 400	4 500	0,25	NKX 45
	58	32	28 100	57 000	28 100	75 000	7 100	2 800	29	3 400	4 500	0,27	NKX 45 Z
50	62	35	38 000	80 000	28 600	81 500	9 650	3 050	34	3 200	4 300	0,28	NKX 50
	62	35	38 000	80 000	28 600	81 500	9 650	3 050	34	3 200	4 300	0,30	NKX 50 Z
60	72	40	41 800	96 500	41 600	122 000	11 800	4 550	77	2 600	3 600	0,36	NKX 60
	72	40	41 800	96 500	41 600	122 000	11 800	4 550	77	2 600	3 600	0,38	NKX 60 Z
70	85	40	44 600	98 000	43 600	137 000	12 200	5 100	97	2 400	3 400	0,50	NKX 70
	85	40	44 600	98 000	43 600	137 000	12 200	5 100	97	2 400	3 400	0,52	NKX 70 Z

¹⁾ Bearing with closure ring insert

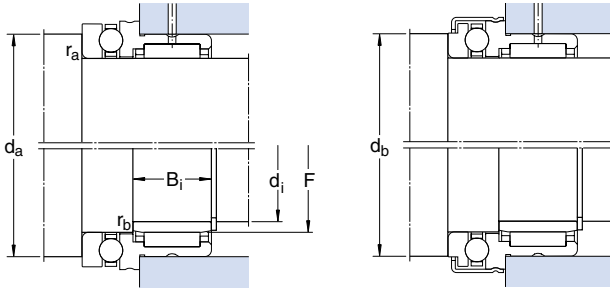

Dimensions				Abutment and fillet dimensions										Appropriate inner ring ¹⁾ Designation	
F_w	C_1	C_2	d	d_1	D_1	D_2	$r_{1,2}$ min	d_a min	d_b max	r_a max	r_b max	d_i	F	B_i	
mm								mm						-	
10	9	6,5	10	24	24	-	0,3	19	-	0,3	0,3	7	10	16	IR 7×10×16
	9	6,5	10	19,7	-	25,2	0,3	19	19,7	0,3	0,3	7	10	16	IR 7×10×16
12	9	6,5	12	26	26	-	0,3	21	-	0,3	0,3	9	12	16	IR 9×12×16
	9	6,5	12	21,7	-	27,2	0,3	21	21,7	0,3	0,3	9	12	16	IR 9×12×16
15	9	6,5	15	28	28	-	0,3	23	-	0,3	0,3	12	15	16	IR 12×15×16
	9	6,5	15	23,7	-	29,2	0,3	23	23,7	0,3	0,3	12	15	16	IR 12×15×16
17	9	8	17	30	30	-	0,3	25	-	0,3	0,3	14	17	17	IR 14×17×17
	9	8	17	25,7	-	31,1	0,3	25	25,7	0,3	0,3	14	17	17	IR 14×17×17
20	10	10,5	20	35	35	-	0,3	29	-	0,3	0,3	17	20	20	IR 17×20×20
	10	10,5	20	30,7	-	36,2	0,3	29	30,7	0,3	0,3	17	20	20	IR 17×20×20
25	11	9,5	25	42	42	-	0,6	35	-	0,6	0,3	20	25	20	IR 20×25×20
	11	9,5	25	37,7	-	43,2	0,6	35	37,7	0,6	0,3	20	25	20	IR 20×25×20
30	11	9,5	30	47	47	-	0,6	40	-	0,6	0,3	25	30	20	IR 25×30×20
	11	9,5	30	42,7	-	48,2	0,6	40	42,7	0,6	0,3	25	30	20	IR 25×30×20
35	12	9	35	52	52	-	0,6	45	-	0,6	0,3	30	35	20	IR 30×35×20
	12	9	35	47,7	-	53,2	0,6	45	47,7	0,6	0,3	30	35	20	IR 30×35×20
40	13	10	40	60	60	-	0,6	52	-	0,6	0,3	35	40	20	IR 35×40×20
	13	10	40	55,7	-	61,2	0,6	52	55,7	0,6	0,3	35	40	20	IR 35×40×20
45	14	9	45	65	65	-	0,6	57	-	0,6	0,3	40	45	20	IR 40×45×20
	14	9	45	60,5	-	66,5	0,6	57	60,5	0,6	0,3	40	45	20	IR 40×45×20
50	14	10	50	70	70	-	0,6	62	-	0,6	0,3	45	50	25	IR 45×50×25
	14	10	50	65,5	-	71,5	0,6	62	65,5	0,6	0,3	45	50	25	IR 45×50×25
60	17	12	60	85	85	-	1	75	-	1	1	50	60	25	IR 50×60×25
	17	12	60	80,5	-	86,5	1	75	80,5	1	1	50	60	25	IR 50×60×25
70	18	11	70	95	95	-	1	85	-	1	1	60	70	25	IR 60×70×25
	18	11	70	90,5	-	96,5	1	85	90,5	1	1	60	70	25	IR 60×70×25

¹⁾ Details of appropriate inner rings will be found in the section "Inner rings" (→ page 204)



Needle roller/cylindrical roller thrust bearings

Product tables page 156

Needle roller/cylindrical roller thrust bearings are combinations of a radial needle roller bearing and a cylindrical roller thrust bearing of series 811. In addition to radial loads they are able to accommodate very heavy axial loads acting in one direction and can therefore locate a shaft in one direction.

Designs

SKF needle roller/cylindrical roller thrust bearings of series NKXR (→ fig 1) are separable. The outer ring with integral housing washer and with the radial needle roller and cage assembly, the cylindrical roller and cage thrust assembly, and the shaft washer can all be mounted individually.

The series NKXR .. Z bearings are non-separable (→ fig 2). A cover is attached to the housing washer (integral with the needle roller bearing outer ring) and extends over the shaft washer, thus holding the bearing together. The cover forms a gap type seal with the shaft washer.

Bearings with cover are particularly suitable for grease lubrication as the cover retains the grease in the bearing, preventing it from being ejected by the cylindrical roller and cage thrust assembly.

The separable bearings of series NKXR, on the other hand, should preferably be lubricated with oil as an adequate oil supply is relatively easy to arrange.

The needle roller/cylindrical roller thrust bearings are supplied without inner ring. For applications where the shaft cannot be hardened and ground, inner rings should be used (→ fig 3). Appropriate inner rings are shown in the product table.

Fig 1

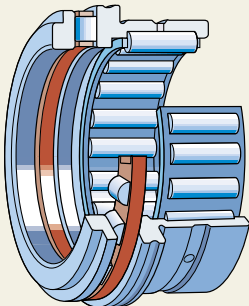

Fig 2



Dimensions

The boundary dimensions of the single direction needle roller/cylindrical roller thrust bearings conform to DIN 5429, Part 1, 1987.

Tolerances

The tolerances to which needle roller/cylindrical roller thrust bearings are produced as standard are given in **Table 1**. The radial runout corresponds to the values given in ISO 492:1994 and the axial runout to ISO 199:1997, for normal tolerances (→ **Tables 2** and **5**, **pages 17** and **20**).

The values for the deviations from the nominal dimension of the ISO tolerance grades given in **Table 1** will be found in **Table 2**.

Fig 3

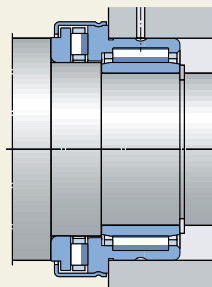

3

Table 1

Needle roller/cylindrical roller thrust bearing tolerances		
Dimension	Tolerance	
Outside diameter	D	Normal, ISO 492:1994
Inside diameter of needle roller complement	F _w	F6
Bore diameter	d	E8
Width	C	0/-0,25 mm
Width	C ₁	0/-0,20 mm

Table 2

ISO tolerances					
Nominal dimension over incl.		E8 Deviations high low		F6 Deviations high low	
mm		µm		µm	
6	10	+47	+25	+22	+13
10	18	+59	+32	+27	+16
18	30	+73	+40	+33	+20
30	50	+89	+50	+41	+25
50	80	+106	+60	+49	+30

Needle roller/cylindrical roller thrust bearings

Internal clearance

It is recommended that the shaft seating for needle roller/cylindrical roller thrust bearings be machined to tolerance k5 and the housing bore seating to tolerance K6. A housing bore tolerance of M6 has been found appropriate for stiff bearing arrangements. The shaft seating tolerance k5 is also appropriate when inner rings are used.

These recommended tolerances will provide a radial internal clearance for the bearing which is somewhat smaller than Normal according to ISO 5753:1991.

Misalignment

Needle roller/cylindrical roller thrust bearings cannot accept any angular misalignment of the shaft with respect to the housing, nor any errors of angle between the support surfaces on the shaft or in the housing.

Cages

The needle rollers of SKF needle roller/cylindrical roller thrust bearings are guided in a cage of steel (→ fig 4), or sheet steel (→ fig 5). The cage which retains the cylindrical rollers of the cylindrical roller thrust bearing is an injection moulded glass fibre reinforced polyamide 6,6 cage (→ fig 6).

NB.

Needle roller/cylindrical roller thrust bearings with polyamide 6,6 cages can be used at temperatures up to +120 °C. With the exception of a few synthetic oils and greases with a synthetic base oil, and lubricants containing a high proportion of EP additives when used at high temperatures, the lubricants generally used for rolling bearings do not have a detrimental effect on cage properties.

For further information regarding the temperature resistance and use of cages, please refer to the section “Cages” (→ page 22).

Fig 4



Fig 5



Fig 6

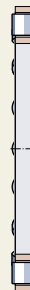

Fig 7

Design of associated components

The diameter of the support surface for the integral housing washer of needle roller/cylindrical roller thrust bearings must always be at least 0,5 mm larger than the dimension D_1 or D_2 (→ fig 7) in order to ensure a clearance fit.

Raceways on the shaft

If the load carrying capacity of the radial needle roller bearing is to be fully exploited then the hardness and surface finish of the raceway machined on the shaft should be the same as those of inner ring raceways. Details of suitable materials, hardness and surface finish will be found in the section “Raceways on shafts and in housings” (→ page 28).

Application recommendations

SKF needle roller/cylindrical roller thrust bearings can axially locate a shaft in one direction. Short shafts, where there is no risk of changes in length occurring in practice as a result of thermal changes, may be supported in two bearings arranged either face-to-face or back-to-back (→ fig 8). In such cases it is recommended that the cylindrical roller thrust bearings be elastically pre-loaded, e.g. by cup springs. This elastic preload serves to ensure proper and quiet performance of the thrust bearing without any slip when it is unloaded.

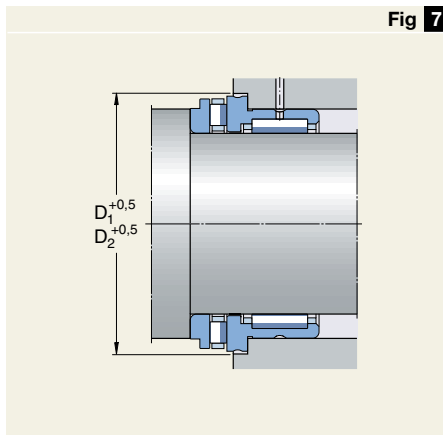

3

Fig 8

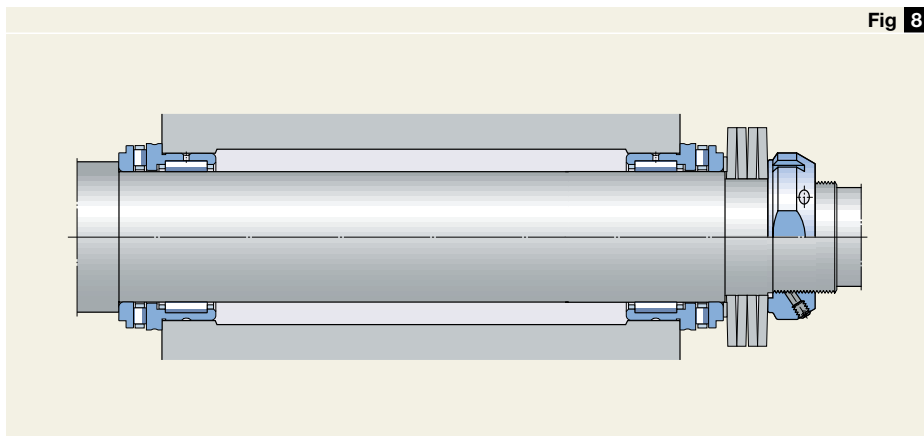

Needle roller/cylindrical roller thrust bearings

Minimum load

In order to guarantee satisfactory operation, needle roller/cylindrical roller thrust bearings, like all ball and roller bearings, must always be subjected to a given minimum load acting in both the radial and axial directions, particularly if they are to operate at high speeds or are subjected to high accelerations or rapid changes in the direction of load. Under such conditions the inertia forces of the rollers and cages, and the friction in the lubricant, can have a detrimental influence on the rolling conditions in the bearing arrangement and may cause damaging sliding movements to occur between the rollers and raceways.

The requisite minimum radial load to be applied to the radial needle roller bearing can be estimated using

$$F_{rm} = 0,02 C$$

The requisite minimum axial load for the cylindrical roller thrust bearing can be obtained from

$$F_{am} = A \left(\frac{n}{1\ 000} \right)^2$$

where

F_{rm} = minimum radial load, N

F_{am} = minimum axial load, N

A = minimum load factor, see product tables

C = basic dynamic load rating, N

n = rotational speed, r/min

When starting up at low temperatures or when the lubricant is highly viscous, even greater loads may be required. The weights of the components supported by the bearing, together with the external forces generally exceed the requisite minimum loads. If this is not the case, the needle roller/cylindrical roller thrust bearing must be subjected to an additional radial and/or axial load.

Equivalent dynamic bearing load

For the radial needle roller bearing

$$P = F_r$$

and for the cylindrical roller thrust bearing

$$P = F_a$$

Equivalent static bearing load

For the radial needle roller bearing

$$P_0 = F_r$$

and for the cylindrical roller thrust bearing

$$P_0 = F_a$$

Load carrying capacity and life

It is necessary to calculate the life of the radial needle roller bearing and of the cylindrical roller thrust bearing separately for needle roller/cylindrical roller thrust bearings.

Needle roller/cylindrical roller thrust bearings

F_w 15 – 50 mm

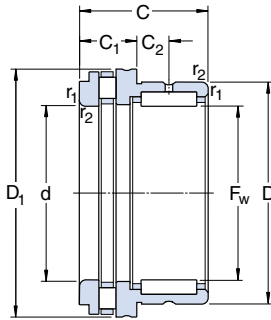

Without cover
Series NKXR

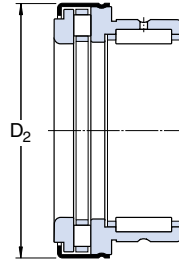

With cover
Series NKXR .. Z

Principal dimensions			Basic load ratings				Fatigue load limits		Min. load factor A	Speed ratings		Mass kg	Designation
F_w	D	C	radial C	static C_0	axial C	static C_0	radial P_u	axial P_u		Lubrication grease oil			
mm	N		N				N		–	r/min	kg	–	
15	24	23	11 200	14 000	11 200	27 000	1 660	2 450	0,058	3 200	4 300	0,042	NKXR 15 NKXR 15 Z
	24	23	11 200	14 000	11 200	27 000	1 660	2 450	0,058	3 200	4 300	0,045	
17	26	25	12 300	16 600	12 200	31 500	1 960	2 850	0,079	3 200	4 300	0,050	NKXR 17 NKXR 17 Z
	26	25	12 300	16 600	12 200	31 500	1 960	2 850	0,079	3 200	4 300	0,053	
20	30	30	16 800	26 000	18 600	48 000	3 050	4 650	0,18	2 800	3 800	0,080	NKXR 20 NKXR 20 Z
	30	30	16 800	26 000	18 600	48 000	3 050	4 650	0,18	2 800	3 800	0,084	
25	37	30	19 000	32 500	25 000	69 500	4 000	6 800	0,39	2 200	3 200	0,12	NKXR 25 NKXR 25 Z
	37	30	19 000	32 500	25 000	69 500	4 000	6 800	0,39	2 200	3 200	0,13	
30	42	30	22 900	39 000	27 000	78 000	4 800	7 650	0,49	2 000	3 000	0,14	NKXR 30 NKXR 30 Z
	42	30	22 900	39 000	27 000	78 000	4 800	7 650	0,49	2 000	3 000	0,14	
35	47	30	24 600	45 000	29 000	93 000	5 600	9 150	0,69	1 900	2 800	0,16	NKXR 35 NKXR 35 Z
	47	30	24 600	45 000	29 000	93 000	5 600	9 150	0,69	1 900	2 800	0,17	
40	52	32	26 400	51 000	43 000	137 000	6 300	13 700	1,5	1 700	2 400	0,20	NKXR 40 NKXR 40 Z
	52	32	26 400	51 000	43 000	137 000	6 300	13 700	1,5	1 700	2 400	0,21	
45	58	32	28 100	57 000	45 000	153 000	7 100	15 300	1,9	1 600	2 200	0,24	NKXR 45 NKXR 45 Z
	58	32	28 100	57 000	45 000	153 000	7 100	15 300	1,9	1 600	2 200	0,26	
50	62	35	38 000	80 000	47 500	166 000	9 650	16 600	2,2	1 600	2 200	0,27	NKXR 50 NKXR 50 Z
	62	35	38 000	80 000	47 500	166 000	9 650	16 600	2,2	1 600	2 200	0,29	

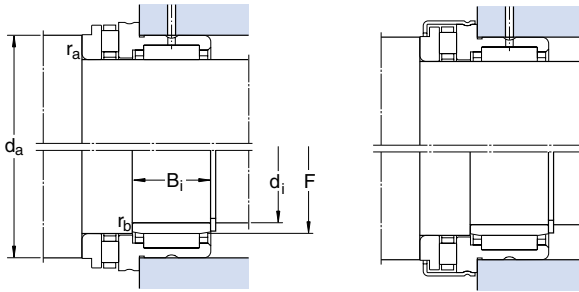

Dimensions							Abutment and fillet dimensions					Appropriate inner ring ¹⁾ Designation	
F_w	C_1	C_2	d	D_1	D_2	$r_{1,2}$ min	d_a	r_a max	r_b max	d_i	F	B_i	
mm							mm					–	
15	9	6,5	15	28	–	0,3	23,7	0,3	0,3	12	15	16	IR 12×15×16
	9	6,5	15	–	29,2	0,3	23,7	0,3	0,3	12	15	16	IR 12×15×16
17	9	8	17	30	–	0,3	25,7	0,3	0,3	14	17	17	IR 14×17×17
	9	8	17	–	31,2	0,3	25,7	0,3	0,3	14	17	17	IR 14×17×17
20	10	10,5	20	35	–	0,3	30,7	0,3	0,3	17	20	20	IR 17×20×20
	10	10,5	20	–	36,2	0,3	30,7	0,3	0,3	17	20	20	IR 17×20×20
25	11	9,5	25	42	–	0,6	37,7	0,6	0,3	20	25	20	IR 20×25×20
	11	9,5	25	–	43,2	0,6	37,7	0,6	0,3	20	25	20	IR 20×25×20
30	11	9,5	30	47	–	0,6	42,7	0,6	0,3	25	30	20	IR 25×30×20
	11	9,5	30	–	48,2	0,6	42,7	0,6	0,3	25	30	20	IR 25×30×20
35	12	9	35	52	–	0,6	47,7	0,6	0,3	30	35	20	IR 30×35×20
	12	9	35	–	53,2	0,6	47,7	0,6	0,3	30	35	20	IR 30×35×20
40	13	10	40	60	–	0,6	55,7	0,6	0,3	35	40	20	IR 35×40×20
	13	10	40	–	61,2	0,6	55,7	0,6	0,3	35	40	20	IR 35×40×20
45	14	9	45	65	–	0,6	60,6	0,6	0,3	40	45	20	IR 40×45×20
	14	9	45	–	66,5	0,6	60,6	0,6	0,3	40	45	20	IR 40×45×20
50	14	10	50	70	–	0,6	65,6	0,6	0,3	45	50	25	IR 45×50×25
	14	10	50	–	71,5	0,6	65,6	0,6	0,3	45	50	25	IR 45×50×25

¹⁾ Details of appropriate inner rings will be found in the section “Inner rings” (→ page 204)



Support rollers

Product tables

Support rollers without axial guidance, without inner ring	page 168
Support rollers without axial guidance, with inner ring	page 170
Support rollers with axial guidance	page 172

SKF support rollers are basically needle or cylindrical roller bearings with a thick-walled outer ring. The outside surface of the outer ring is crowned which serves to prevent edge stresses if the roller runs in a tilted or inclined position. They are ready-to-mount units which are filled with grease and are suitable for all types of cam drives, tracks and conveyor systems etc.

SKF support rollers are available

- without axial guidance (→ **fig 1**) and
- with axial guidance (→ **fig 2**).

The support rollers without axial guidance are supplied in a non-sealed (open) design and a sealed version. Five series of support

roller with axial guidance are available. Four of the series have the same dimensions, differing only in their internal design.

3

Fig 1

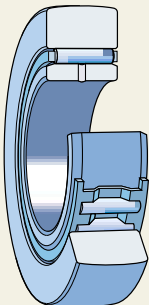
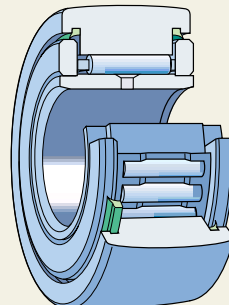

Fig 2



Support rollers

Support rollers without axial guidance

SKF support rollers without axial guidance are designed for applications where the associated components can be designed to provide axial guidance. The support rollers without inner ring are intended for arrangements where the pin or shaft can be hardened and ground.

The inner rings of support rollers with inner ring are slightly extended to ensure the necessary axial play.

Support rollers of the (R)STO design

Support rollers of the (R)STO design are particularly simple in design. The support rollers with inner ring (→ **fig 3**) have the series designation STO, while those without inner ring (→ **fig 4**) are identified by the prefix R; the series designation being RSTO. All components of these support rollers can be mounted separately.

Support rollers of the STO design can be used for applications where grease lubrication is employed as well as for oil-lubricated applications. Where oil is to be used, it is recommended that the grease contained in the roller on delivery is washed out first.

Support rollers of the (R)NA 22.2RS design

Support rollers of the (R)NA 22.2RS design are fitted with rubbing seals of oil and wear-resistant nitrile rubber (NBR) which are suitable for operating temperatures between -30 and $+120$ °C. They are designed for applications where particulate contamination is light to moderate and there is a possibility of moisture penetrating.

The needle roller and cage assembly of the rollers is axially guided between two integral flanges in the outer ring and forms a non-separable unit with the outer ring. The inner ring of the NA 22.2RS bearings (→ **fig 5**) can be mounted separately. When the outer ring assembly and inner ring are joined, care must be taken not to damage the lips of the seals. Support rollers of series RNA 22.2RS (→ **fig 6**) are without inner ring.

Fig 3

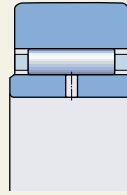

Fig 4

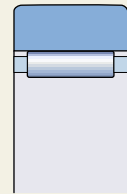

Fig 5

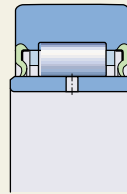
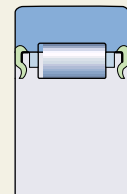

Fig 6



Support rollers with axial guidance

SKF support rollers with axial guidance are non-separable units and are especially suitable for applications where lateral (thrust) surfaces are not available. Thrust forces resulting from alignment errors or inclined running are taken up by side washers or flange rings; the side washers are either loose or pressed on to the inner ring. When designing the associated components and mounting the support rollers it is important to ensure that the flange rings and inner rings with pressed-on washers are located without axial play. If larger thrust forces are expected, it is recommended that axial support is also provided for the washers which are pressed on to the inner ring (→ “Design of associated components”, **page167**).

Support rollers of the NATR design

Support rollers of the NATR design (→ **fig 7**) incorporate cage-guided needle rollers and permit relatively high speed operation. The outer ring is guided by the side washers which are pressed on to the inner ring; the washers form gap-type seals with the outer ring.

The outer ring is particularly thick-walled and intended for heavy loads and also shock loads.

Support rollers of the NATV design

Support rollers of the NATV design (→ **fig 8**) are similar to those of the NATR design except that they have a full complement of rollers. The absence of a cage enables the maximum number of needle rollers to be incorporated so that these support rollers can carry even heavier loads than those of the NATR design. However, because of the kinematic conditions they are not able to operate at such high speeds. They also require more frequent relubrication.

Fig 7

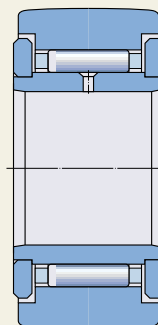
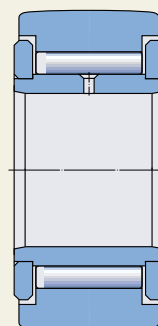

Fig 8



Support rollers

Sealed NATR and NATV support rollers – PP and PPA designs

Support rollers of the NATR and NATV series can also be supplied with rubbing seals. Sealed support rollers are intended for universal application, but particularly for use where difficult conditions pertain which call for efficient sealing of the bearing position.

Support rollers of the PP design (→ **fig 9**) have seals of nitrile rubber (NBR) or polyurethane at both sides and are suitable for operating temperatures from -30 to $+100$ °C. They are being gradually replaced by the more robust PPA design.

The seals of support rollers of the PPA design are replaced by sliding thrust washers of polyamide 6,6 (→ **fig 10**). These reduce the sliding friction between the outer ring and side washer and allow a reduction in the running temperature of the roller; this is favourable with regard to the service life of the grease. The sliding washer has the form of a cup spring with a sealing lip and acts as an axial seal which reliably retains grease in the roller. In the radial direction a narrow labyrinth is formed with the outer ring which excludes coarse contaminants. The permissible operating temperature range for the sealed support rollers is -30 to $+100$ °C.

All support rollers of the PPA design have an enhanced runner profile (outside diameter of outer ring). The new design allows a more favourable distribution of stress than the crowned profile of the earlier design, even when running in a tilted position. This leads to higher stiffness and less wear between the runner surface and its counterface.

Fig 9

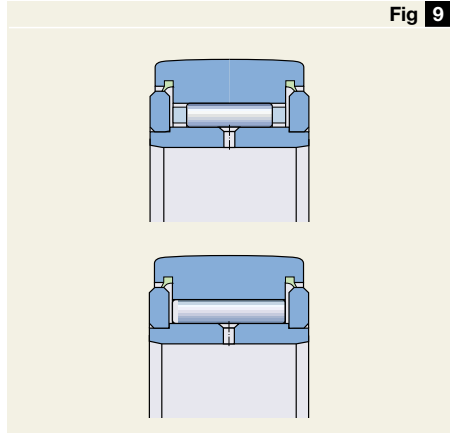
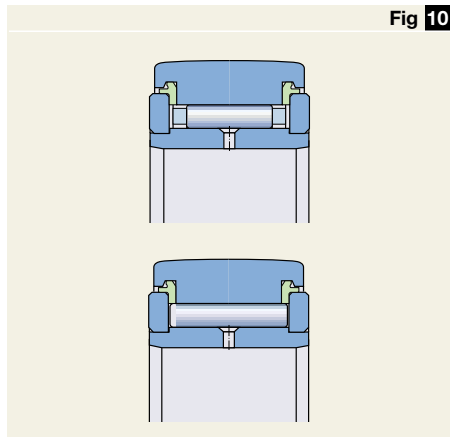

Fig 10



Support rollers of the NUTR design

Support rollers of the NUTR design (→ **fig 11**) are based on double row full complement cylindrical roller bearings. The outer ring has two integral flanges, which axially guide the roller complement. Two loose flange rings provide axial guidance for the outer ring via the roller complement. Sheet metal angle rings pressed into the outer ring and extending over the flange rings serve to hold the components together and form efficient labyrinth seals.

NUTR support rollers can accommodate heavy radial loads. As the outer ring is guided by the rollers large axial forces can also be taken up. The support rollers can also be operated at relatively high speeds. Being of the full complement type, these support rollers require more frequent relubrication.

If heavy shock loads can be expected, the rollers with reinforced outer ring should be used. These are identified by four or five-figure numbers in the designation.

NUTR support rollers also have an enhanced runner profile (outside diameter of outer ring) identified by suffix A in the designation. The new design allows a more favourable distribution of stress than the crowned profile of the earlier design, even when running in a tilted position. This leads to higher stiffness and less wear between the runner surface and its counterface.

Support rollers of the PWTR.2RS design

Support rollers of series PWTR.2RS (→ **fig 12**) are sealed and therefore particularly suitable for operation under arduous conditions. The outer ring has three integral flanges, which axially guide the two rows of rollers (full complement) separately. Two loose flange rings provide axial guidance for the outer ring via the roller complements. Sheet metal angle rings pressed into the outer ring and extending over the flange rings serve to hold the components together. Rubbing seals, of oil and wear-resistant nitrile rubber (NBR), are integral with the angle rings and seal against the flange rings.

The special features of these support rollers include the rubbing seals, the three integral outer ring flanges and the large

Fig 11

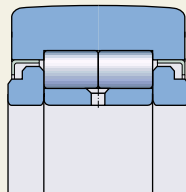
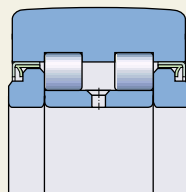

Fig 12



space between the two rows of rollers. The separate guidance of the two rows of rollers means that friction in the support roller is low and thus also heat generation. The PWTR support rollers are very suitable for the accommodation of axial forces, which can occur if the roller runs in an inclined position.

The large space between the two rows of rollers allows a large quantity of grease to be incorporated and the rubbing seals provide efficient protection against contamination. It is therefore possible to operate support rollers of series PWTR.2RS for much longer periods between maintenance intervals than was previously possible, even under contaminated conditions. The permissible operating temperature range is -30 to $+120$ °C.

Support rollers

Support rollers of the NNTR.2ZL design

Support rollers of series NNTR.2ZL (→ **fig 13**) are large and can carry very heavy loads. The outer ring has three integral flanges which axially guide the two rows of rollers (full complement) separately. Two loose flange rings provide axial guidance for the outer ring via the roller complements. The NNTR support rollers incorporate lamellar seals at both sides. These are inserted in grooves in the shoulders of the flange rings and in the outer ring shoulders and hold all the bearing components together.

The separate guidance of the two roller rows reduces friction and thus heat generation. The NNTR support rollers are thus suitable for the accommodation of heavy axial loads, even when they act constantly, which can occur, for example, if the roller runs in an inclined position. The double row full complement of rollers imparts high radial load carrying capacity.

The large free space between the two rows of rollers means that a large quantity of grease can be filled into the rollers. The lamellar seals provide efficient protection. Extended maintenance intervals are therefore possible, even under difficult conditions.

Fig 13

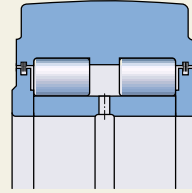

Dimensions

The dimensions of the support rollers of series (R)NA 22.2RS conform to ISO 15:1998. The dimensions of the support rollers of series NATR, NATV, NUTR and PWTR, where standardised, conform to ISO 6278-1980 and ANSI/AFBMA Standard 16.1-1988 as well as ANSI/AFBMA Standard 18.1-1976.

Tolerances

SKF support rollers are produced to Normal tolerances in accordance with ISO 492:1994 (→ Table 2, page 17) with the following exceptions:

- the tolerance for the outside diameter surface of the roller with its modified profile is 0/−0,050 mm;
- the width B of support rollers of series NATR, NATV and NUTR corresponds to h12;
- the circularity of the inner rings of support rollers of series NATR and NATV.

The diameter under the roller sets, F_{w1} , of support rollers without inner ring, series RSTO and RNA 22.2RS lies within the limits of F6.

The limits for tolerances h12 and F6 will be found in Table 1.

Internal clearance

SKF support rollers of series STO and NA 22.2RS are produced as standard with Normal radial internal clearance as specified in ISO 5753:1991. The other support rollers have a clearance in the C2 range corresponding to class 2 according to ISO 5753:1991 (→ Table 6, page 21).

Load carrying capacity

In contrast to normal roller bearings, where the outer ring is supported over its entire outside diameter surface in the bore of a housing, the outer ring of a support roller only has a small area of contact with the surface against which it runs, e.g. a rail or cam. The deformation of the outer ring caused by this limited contact alters the force distribution in the bearing and thus has an influence on life and load carrying capacity. The basic load ratings given in the table section take this into account.

Table 1

ISO tolerances					
Nominal dimension over incl.		h12 Deviations high low		F6 Deviations high low	
mm		µm		µm	
3	6	0	-120	+18	+10
6	10	0	-150	+22	+13
10	18	0	-180	+27	+16
18	30	0	-210	+33	+20
30	50	0	-250	+41	+25
50	80	0	-300	+49	+30
80	120	0	-350	+58	+36

The ability to carry dynamic loads depends on the requisite life, but it is important with reference to the strength and deformation of the outer ring that the value of the maximum dynamic radial load F_r quoted in the table section is not exceeded.

The permissible static load for a support roller is determined by the smaller of the values of F_{0r} and C_0 . If requirements regarding smooth running are below normal, the static load may exceed C_0 but should never exceed the maximum permissible static radial load F_{0r} .

Support rollers

Cages

The cages of support rollers of series STO, NA 22.2RS and NATR are made of steel (→ fig 14), except for those rollers of the STO design which are identified by the designation suffix TN. These rollers have a cage of glass fibre reinforced polyamide 6,6 (→ fig 15).

NB.

The support rollers with polyamide cages can be operated at temperatures up to +120 °C and cage properties are not affected by the lubricant used.

For further information regarding the temperature resistance and use of cages, please refer to the section “Cages” (→ page 22).

Lubrication

All support rollers are supplied as standard filled with a high-quality lithium complex base grease is based on mineral oil and of consistency 2 to the NLGI Scale. The grease is based on mineral oil and has good rust inhibiting properties. It has an operating temperature range of –25 to +150 °C.

SKF support rollers require little maintenance. To exploit their full service life, they must, however, be relubricated, preferably while the first grease fill still has its full lubricating properties. A lubrication hole is provided in the inner ring so that if suitable ducts are provided in the pin, the support rollers are easy to relubricate. Generally, where loads are light, speeds relatively low and the surroundings clean, support rollers can operate for long periods without relubrication. If, however, the environment is contaminated and damp, frequent relubrication is required as it is also if speeds are high or the operating temperature above +70 °C.

For relubrication it is recommended that SKF grease be used – grease LGMT 2 or preferably LGWA 2. This is a lithium complex grease with a mineral oil base and has good rust inhibiting properties.

Fig 14

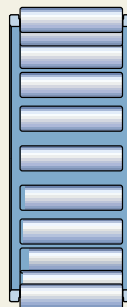

Fig 15

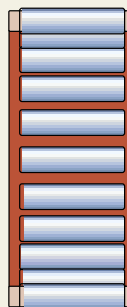

Fig 16

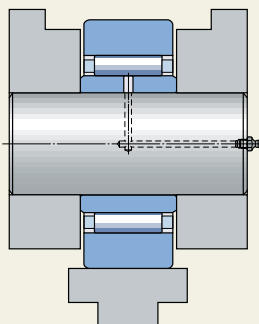
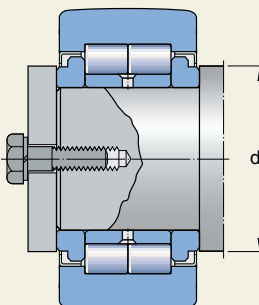

Fig 17



Design of associated components

The support surfaces for the outer rings of the support rollers without axial guidance should be at least fine turned and be free of burrs and clean. Unhardened surfaces should extend to at least half the outer ring side face (→ fig 16) whilst hardened surfaces may be smaller. Support rollers without inner ring, series RSTO and RNA 22.2RS, must have a clearance of 0,2 mm to the support surfaces. Details regarding the design of raceways on pins will be found in the section “Raceways on shafts and in housings” (→ page 28).

For support rollers with axial guidance which are to be heavily loaded, it is recommended that complete support is provided for the side washers and that the support surface is dimensioned according to the diameter d_1 (→ fig 17).

Tolerances for pins

With very few exceptions, support rollers operate under conditions of stationary inner ring load. For this type of load, and if easy displacement of the inner ring is required, the pins should be machined to tolerance g6. The appropriate tolerance for pins for support rollers without inner ring is k5.

Mounting instructions

Care should be taken to see that the lubrication hole in the inner ring is in the unloaded zone of the support roller after mounting.

It should be noted that the inner ring and the two loose flange rings of support rollers of series NUTR, PWTR.2RS and NNTR.2ZL should be firmly clamped together when mounted.

**Support rollers without axial guidance,
without inner ring**
D 16 – 90 mm

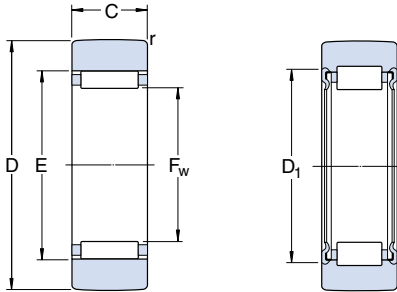

Series RSTO

Series RNA 22.2RS

Dimensions						Speed rating	Mass	Designation
D	C	D ₁	F _w	E	r min	r/min	kg	–
mm						r/min	kg	–
16	7,8	–	7	10	0,3	16 000	0,0085	RSTO 5 TN
19	9,8 11,8	– 16	10 10	13	0,3 0,3	10 000 9 000	0,013 0,018	RSTO 6 TN RNA 22/6.2RS
24	9,8 11,8	– 18	12 12	15	0,3 0,3	8 000 7 000	0,021 0,029	RSTO 8 TN RNA 22/8.2RS
30	11,8 13,8	– 20	14 14	20	0,3 0,6	5 500 5 500	0,042 0,052	RSTO 10 RNA 2200.2RS
32	11,8 13,8	– 22	16 16	22	0,3 0,6	4 500 4 700	0,049 0,057	RSTO 12 RNA 2201.2RS
35	11,8 13,8	– 26	20 20	26	0,3 0,6	3 300 3 400	0,050 0,060	RSTO 15 RNA 2202.2RS
40	15,8 15,8	– 28	22 22	29	0,3 1	2 800 3 000	0,088 0,094	RSTO 17 RNA 2203.2RS
47	15,8 17,8	– 33	25 25	32	0,3 1	2 400 2 300	0,13 0,15	RSTO 20 RNA 2204.2RS
52	15,8 17,8	– 38	30 30	37	0,3 1	1 800 1 800	0,15 0,18	RSTO 25 RNA 2205.2RS
62	19,8 19,8	– 43	38 35	46	0,6 1	1 300 1 400	0,26 0,28	RSTO 30 RNA 2206.2RS
72	19,8 22,7	– 50	42 42	50	0,6 1,1	1 100 1 100	0,38 0,43	RSTO 35 RNA 2207.2RS
80	19,8 22,7	– 57	50 48	58	1 1,1	850 850	0,42 0,53	RSTO 40 RNA 2208.2RS
85	19,8 22,7	– 62	55 52	63	1 1,1	750 800	0,45 0,55	RSTO 45 RNA 2209.2RS
90	19,8 22,7	– 68	60 58	68	1 1,1	650 650	0,48 0,56	RSTO 50 RNA 2210.2RS

Designation	Basic load ratings		Fatigue load limit P_u	Maximum radial forces	
	dynamic C	static C_0		dynamic P_u	static F_r F_{Or}
–	N		N	N	
RSTO 5 TN	2 510	2 500	270	3 550	5 000
RSTO 6 TN	3 740	4 500	500	4 250	6 100
RNA 22/6.2RS	3 520	3 000	340	1 930	2 750
RSTO 8 TN	4 130	5 400	600	7 500	10 800
RNA 22/8.2RS	4 460	4 400	500	5 000	7 100
RSTO 10	8 250	8 800	1 040	8 500	12 200
RNA 2200.2RS	6 440	7 200	850	12 000	17 000
RSTO 12	8 800	9 800	1 180	8 300	12 000
RNA 2201.2RS	6 930	8 150	965	11 600	16 600
RSTO 15	9 130	10 600	1 270	7 100	10 000
RNA 2202.2RS	7 210	9 000	1 040	9 650	13 700
RSTO 17	14 200	17 600	2 080	12 000	17 300
RNA 2203.2RS	9 350	12 900	1 530	16 000	22 800
RSTO 20	16 100	21 200	2 500	18 600	26 500
RNA 2204.2RS	15 400	17 300	2 120	17 600	25 500
RSTO 25	16 500	22 800	2 700	18 000	26 000
RNA 2205.2RS	16 100	19 000	2 320	17 300	24 500
RSTO 30	22 900	34 500	4 250	23 600	33 500
RNA 2206.2RS	17 600	24 500	3 000	28 500	40 500
RSTO 35	24 600	39 000	4 800	36 000	51 000
RNA 2207.2RS	22 000	34 000	4 300	39 000	56 000
RSTO 40	23 800	39 000	4 750	34 500	49 000
RNA 2208.2RS	27 000	39 000	4 900	37 500	53 000
RSTO 45	25 100	43 000	5 300	34 500	50 000
RNA 2209.2RS	27 500	41 500	5 200	39 000	56 000
RSTO 50	26 000	45 500	5 700	34 500	50 000
RNA 2210.2RS	27 000	41 500	5 200	36 500	52 000

**Support rollers without axial guidance,
with inner ring**
D 19–90 mm

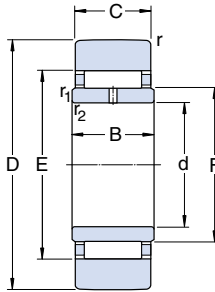

Series STO

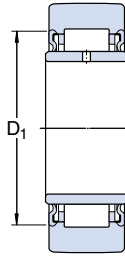

Series NA 22.2RS

Dimensions									Speed rating	Mass	Designation
D	C	B	d	D ₁	F	E	r min	r _{1,2} min	r/min	kg	–
mm									r/min	kg	–
19	9,8	10	6	–	10	13	0,3	0,3	10 000	0,017	STO 6 TN NA 22/6.2RS
	11,8	12	6	16	10	–	0,3	0,3	9 000	0,022	
24	9,8	10	8	–	12	15	0,3	0,3	8 000	0,026	STO 8 TN NA 22/8.2RS
	11,8	12	8	18	12	–	0,3	0,3	7 000	0,034	
30	11,8	12	10	–	14	20	0,3	0,3	5 500	0,049	STO 10 NA 2200.2RS
	13,8	14	10	20	14	–	0,6	0,3	5 500	0,060	
32	11,8	12	12	–	16	22	0,3	0,3	4 500	0,057	STO 12 NA 2201.2RS
	13,8	14	12	22	16	–	0,6	0,3	4 700	0,067	
35	11,8	12	15	–	20	26	0,3	0,3	3 300	0,063	STO 15 NA 2202.2RS
	13,8	14	15	26	20	–	0,6	0,3	3 400	0,075	
40	15,8	16	17	–	22	29	0,3	0,3	2 800	0,11	STO 17 NA 2203.2RS
	15,8	16	17	28	22	–	1	0,3	3 000	0,11	
47	15,8	16	20	–	25	32	0,3	0,3	2 400	0,15	STO 20 NA 2204.2RS
	17,8	18	20	33	25	–	1	0,3	2 300	0,18	
52	15,8	16	25	–	30	37	0,3	0,3	1 800	0,18	STO 25 NA 2205.2RS
	17,8	18	25	38	30	–	1	0,3	1 800	0,21	
62	19,8	20	30	–	38	46	0,6	0,6	1 300	0,31	STO 30 NA 2206.2RS
	19,8	20	30	43	35	–	1	0,3	1 400	0,32	
72	19,8	20	35	–	42	50	0,6	0,6	1 100	0,44	STO 35 NA 2207.2RS
	22,7	23	35	50	42	–	1,1	0,6	1 100	0,51	
80	19,8	20	40	–	50	58	1	1	850	0,53	STO 40 NA 2208.2RS
	22,7	23	40	57	48	–	1,1	0,6	850	0,63	
85	19,8	20	45	–	55	63	1	1	750	0,58	STO 45 NA 2209.2RS
	22,7	23	45	62	52	–	1,1	0,6	800	0,66	
90	19,8	20	50	–	60	68	1	1	650	0,62	STO 50 NA 2210.2RS
	22,7	23	50	68	58	–	1,1	0,6	650	0,69	

Designation	Basic load ratings		Fatigue load limit P_u	Maximum radial forces	
	dynamic C	static C_0		dynamic F_r	static F_{0r}
–	N		N	N	
STO 6 TN	3 740	4 500	500	4 250	6 100
NA 22/6.2RS	3 520	3 000	340	1 930	2 750
STO 8 TN	4 130	5 400	600	7 500	10 800
NA 22/8.2RS	4 460	4 400	500	5 000	7 100
STO 10	8 250	8 800	1 040	8 500	12 200
NA 2200.2RS	6 440	7 200	850	12 000	17 000
STO 12	8 800	9 800	1 180	8 300	12 000
NA 2201.2RS	6 930	8 150	965	11 600	16 600
STO 15	9 130	10 600	1 270	7 100	10 000
NA 2202.2RS	7 210	9 000	1 040	9 650	13 700
STO 17	14 200	17 600	2 080	12 000	17 300
NA 2203.2RS	9 350	12 900	1 530	16 000	22 800
STO 20	16 100	21 200	2 500	18 600	26 500
NA 2204.2RS	15 400	17 300	2 120	17 600	25 500
STO 25	16 500	22 800	2 700	18 000	26 000
NA 2205.2RS	16 100	19 000	2 320	17 300	24 500
STO 30	22 900	34 500	4 250	23 600	33 500
NA 2206.2RS	17 600	24 500	3 000	28 500	40 500
STO 35	25 500	40 500	5 000	36 000	51 000
NA 2207.2RS	22 000	34 000	4 300	39 000	56 000
STO 40	23 800	39 000	4 750	34 500	49 000
NA 2208.2RS	27 000	39 000	4 900	37 500	53 000
STO 45	25 100	43 000	5 300	34 500	50 000
NA 2209.2RS	27 500	41 500	5 200	39 000	56 000
STO 50	26 000	45 500	5 700	34 500	50 000
NA 2210.2RS	27 000	41 500	5 200	36 500	52 000

Support rollers with axial guidance
D 16–32 mm

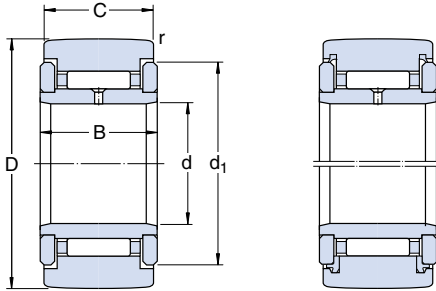

Series NATR

Series NATR .. PP
 Series NATR .. PPA

Dimensions						Speed rating	Mass	Designation ¹⁾
D	C	B	d	d ₁	r min			
mm						r/min	kg	–
16	5	11	12	12,5	0,15	14 000	0,014	NATR 5
	5	11	12	12,5	0,15	14 000	0,014	NATR 5 PP
	5	11	12	12,5	0,15	14 000	0,014	NATR 5 PPA
	5	11	12	12,5	0,15	3 800	0,015	NATV 5
	5	11	12	12,5	0,15	3 800	0,015	NATV 5 PP
	5	11	12	12,5	0,15	3 800	0,015	NATV 5 PPA
19	6	11	12	15	0,15	11 000	0,020	NATR 6
	6	11	12	15	0,15	11 000	0,020	NATR 6 PP
	6	11	12	15	0,15	11 000	0,019	NATR 6 PPA
	6	11	12	15	0,15	3 100	0,021	NATV 6
	6	11	12	15	0,15	3 100	0,021	NATV 6 PP
	6	11	12	15	0,15	3 100	0,021	NATV 6 PPA
24	8	14	15	19	0,3	7 500	0,041	NATR 8
	8	14	15	19	0,3	7 500	0,041	NATR 8 PP
	8	14	15	19	0,3	7 500	0,038	NATR 8 PPA
	8	14	15	19	0,3	2 500	0,042	NATV 8
	8	14	15	19	0,3	2 500	0,042	NATV 8 PP
	8	14	15	19	0,3	2 500	0,041	NATV 8 PPA
30	10	14	15	23	0,6	5 500	0,064	NATR 10
	10	14	15	23	0,6	5 500	0,064	NATR 10 PP
	10	14	15	23	0,6	5 500	0,061	NATR 10 PPA
	10	14	15	23	0,6	2 100	0,065	NATV 10
	10	14	15	23	0,6	2 100	0,065	NATV 10 PP
	10	14	15	23	0,6	2 100	0,064	NATV 10 PPA
32	12	14	15	25	0,6	4 500	0,071	NATR 12
	12	14	15	25	0,6	4 500	0,071	NATR 12 PP
	12	14	15	25	0,6	4 500	0,066	NATR 12 PPA
	12	14	15	25	0,6	1 800	0,072	NATV 12
	12	14	15	25	0,6	1 800	0,072	NATV 12 PP
	12	14	15	25	0,6	1 800	0,069	NATV 12 PPA

¹⁾ All support rollers of the PP design (designation printed in grey) will be gradually replaced by the PPA design

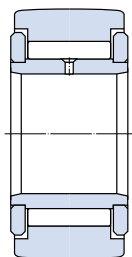

Series NATV

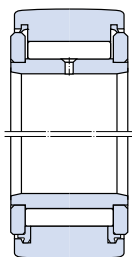

Series NATV .. PP
Series NATV .. PPA

Designation ¹⁾	Basic load ratings		Fatigue load limits P_u	Maximum radial forces	
	dynamic C	static C_0		dynamic F_r	static F_{0r}
–	N		N	N	
NATR 5	3 140	3 200	345	2 900	4 150
NATR 5 PP	3 140	3 200	345	2 900	4 150
NATR 5 PPA	3 140	3 200	345	2 900	4 150
NATV 5	4 730	6 550	720	4 050	5 700
NATV 5 PP	4 730	6 550	720	4 050	5 700
NATV 5 PPA	4 730	6 550	720	4 050	5 700
NATR 6	3 470	3 800	415	3 800	5 500
NATR 6 PP	3 470	3 800	415	3 800	5 500
NATR 6 PPA	3 470	3 800	415	3 800	5 500
NATV 6	5 280	8 000	880	5 100	7 350
NATV 6 PP	5 280	8 000	880	5 100	7 350
NATV 6 PPA	5 280	8 000	880	5 100	7 350
NATR 8	5 280	6 100	695	5 200	7 350
NATR 8 PP	5 280	6 100	695	5 200	7 350
NATR 8 PPA	5 280	6 100	695	5 200	7 350
NATV 8	7 480	11 400	1 320	7 350	10 400
NATV 8 PP	7 480	11 400	1 320	7 350	10 400
NATV 8 PPA	7 480	11 400	1 320	7 350	10 400
NATR 10	6 440	8 000	880	7 800	11 200
NATR 10 PP	6 440	8 000	880	7 800	11 200
NATR 10 PPA	6 440	8 000	880	7 800	11 200
NATV 10	8 970	14 600	1 660	11 000	15 600
NATV 10 PP	8 970	14 600	1 660	11 000	15 600
NATV 10 PPA	8 970	14 600	1 660	11 000	15 600
NATR 12	6 600	8 500	950	7 650	10 800
NATR 12 PP	6 600	8 500	950	7 650	10 800
NATR 12 PPA	6 600	8 500	950	7 650	10 800
NATV 12	9 350	15 300	1 760	10 600	15 000
NATV 12 PP	9 350	15 300	1 760	10 600	15 000
NATV 12 PPA	9 350	15 300	1 760	10 600	15 000

¹⁾ All support rollers of the PP design (designation printed in grey) will be gradually replaced by the PPA design



Support rollers with axial guidance

D 35 – 47 mm

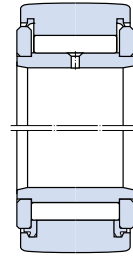
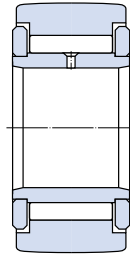
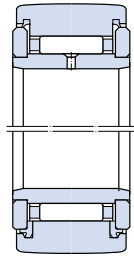
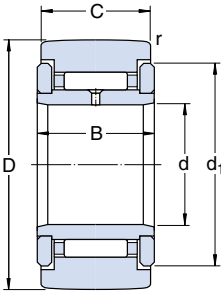

Series NATR

Series NATR .. PP
Series NATR .. PPA

Series NATV

Series NATV .. PP
Series NATV .. PPA

Dimensions					Speed rating		Mass	Designation ¹⁾	
D	C	B	d	d ₁	r min	r ₁ min	r/min	kg	
mm							r/min	kg	–
35	15	18	19	27,6	0,6	–	3 600	0,10	NATR 15
	15	18	19	27,6	0,6	–	3 600	0,10	NATR 15 PP
	15	18	19	27,6	0,6	–	3 600	0,095	NATR 15 PPA
	15	18	19	27,6	0,6	–	1 600	0,11	NATV 15
	15	18	19	27,6	0,6	–	1 600	0,11	NATV 15 PP
	15	18	19	27,6	0,6	–	1 600	0,10	NATV 15 PPA
	15	18	19	20	0,6	0,3	6 500	0,10	NUTR 15 A
	15	18	19	20	0,6	0,3	6 000	0,10	PWTR 15.2RS
40	17	20	21	31,5	1	–	2 900	0,14	NATR 17
	17	20	21	31,5	1	–	2 900	0,14	NATR 17 PP
	17	20	21	31,5	1	–	2 900	0,14	NATR 17 PPA
	17	20	21	31,5	1	–	1 400	0,15	NATV 17
	17	20	21	31,5	1	–	1 400	0,15	NATV 17 PP
	17	20	21	31,5	1	–	1 400	0,15	NATV 17 PPA
	17	20	21	22	1	0,5	5 500	0,15	NUTR 17 A
	17	20	21	22	1	0,5	5 000	0,15	PWTR 17.2RS
42	15	18	19	20	0,6	0,3	6 500	0,16	NUTR 1542 A
	15	18	19	20	0,6	0,3	6 000	0,16	PWTR 1542.2RS
47	17	20	21	22	1	0,5	5 500	0,22	NUTR 1747 A
	17	20	21	22	1	0,5	5 000	0,22	PWTR 1747.2RS
	20	24	25	36,5	1	–	2 400	0,25	NATR 20
	20	24	25	36,5	1	–	2 400	0,25	NATR 20 PP
	20	24	25	36,5	1	–	2 400	0,24	NATR 20 PPA
	20	24	25	36,5	1	–	1 300	0,25	NATV 20
	20	24	25	36,5	1	–	1 300	0,25	NATV 20 PP
	20	24	25	36,5	1	–	1 300	0,25	NATV 20 PPA
	20	24	25	27	1	0,5	4 200	0,25	NUTR 20 A
	20	24	25	27	1	0,5	3 800	0,25	PWTR 20.2RS

¹⁾ All support rollers of the PP design (designation printed in grey) will be gradually replaced by the PPA design

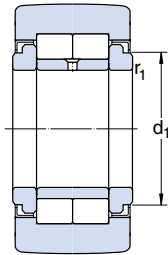

Series NUTR .. A

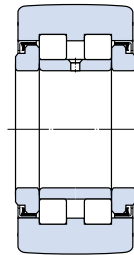

Series PWTR.2RS

Designation ¹⁾	Basic load ratings		Fatigue load limits P_u	Maximum radial forces	
	dynamic C	static C_0		dynamic F_r	static F_{0r}
–	N		N	N	
NATR 15	9 520	13 700	1 560	11 400	16 300
NATR 15 PP	9 520	13 700	1 560	11 400	16 300
NATR 15 PPA	9 520	13 700	1 560	11 400	16 300
NATV 15	12 300	23 200	2 700	14 600	20 800
NATV 15 PP	12 300	23 200	2 700	14 600	20 800
NATV 15 PPA	12 300	23 200	2 700	14 600	20 800
NUTR 15 A	16 800	17 600	2 000	8 650	12 200
PWTR 15.2RS	11 900	11 400	1 200	8 650	12 500
NATR 17	10 500	14 600	1 730	12 500	18 000
NATR 17 PP	10 500	14 600	1 730	12 500	18 000
NATR 17 PPA	10 500	14 600	1 730	12 500	18 000
NATV 17	14 200	26 500	3 100	17 000	24 500
NATV 17 PP	14 200	26 500	3 100	17 000	24 500
NATV 17 PPA	14 200	26 500	3 100	17 000	24 500
NUTR 17 A	19 000	22 000	2 500	14 000	20 000
PWTR 17.2RS	13 800	14 300	1 500	13 700	19 600
NUTR 1542 A	20 100	23 200	2 650	21 600	31 000
PWTR 1542.2RS	14 200	15 000	1 600	22 000	31 500
NATR 1747 A	22 000	27 000	3 050	30 000	43 000
PWTR 1747.2RS	15 700	17 600	1 860	30 000	42 500
NATR 20	14 700	24 500	2 900	23 600	33 500
NATR 20 PP	14 700	24 500	2 900	23 600	33 500
NATR 20 PPA	14 700	24 500	2 900	23 600	33 500
NATV 20	19 400	41 500	5 000	30 500	43 000
NATV 20 PP	19 400	41 500	5 000	30 500	43 000
NATV 20 PPA	19 400	41 500	5 000	30 500	43 000
NUTR 20 A	28 600	33 500	3 900	17 600	25 000
PWTR 20.2RS	22 900	24 500	2 800	18 300	26 000



¹⁾ All support rollers of the PP design (designation printed in grey) will be gradually replaced by the PPA design

Support rollers with axial guidance

D 52 – 80 mm

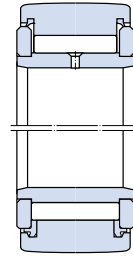
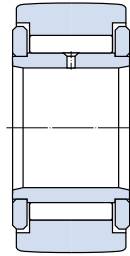
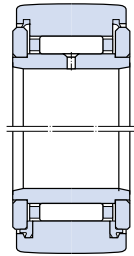
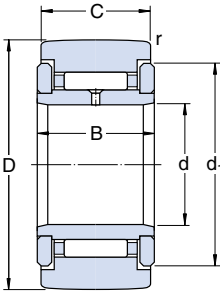

Series NATR

Series NATR .. PP
Series NATR .. PPA

Series NATV

Series NATV .. PP
Series NATV .. PPA

Dimensions							Speed rating	Mass	Designation ¹⁾
D	C	B	d	d ₁	r min	r ₁ min	r/min	kg	–
mm							r/min	kg	–
52	20	24	25	27	1	0,5	4 200	0,32	NUTR 2052 A
	20	24	25	27	1	0,5	3 800	0,32	PWTR 2052.2RS
	25	24	25	41,5	1	–	1 800	0,28	NATR 25
	25	24	25	41,5	1	–	1 800	0,28	NATR 25 PP
	25	24	25	41,5	1	–	1 800	0,27	NATR 25 PPA
	25	24	25	41,5	1	–	1 000	0,29	NATV 25
	25	24	25	41,5	1	–	1 000	0,29	NATV 25 PP
	25	24	25	41,5	1	–	1 000	0,28	NATV 25 PPA
	25	24	25	31	1	0,5	4 200	0,28	NUTR 25 A
	25	24	25	31	1	0,5	2 800	0,28	PWTR 25.2RS
62	25	24	25	31	1	0,5	3 400	0,45	NUTR 2562 A
	25	24	25	31	1	0,5	2 800	0,45	PWTR 2562.2RS
	30	28	29	51	1	–	1 300	0,47	NATR 30
	30	28	29	51	1	–	1 300	0,47	NATR 30 PP
	30	28	29	51	1	–	1 300	0,44	NATR 30 PPA
	30	28	29	51	1	–	850	0,48	NATV 30
	30	28	29	51	1	–	850	0,48	NATV 30 PP
	30	28	29	51	1	–	850	0,47	NATV 30 PPA
	30	28	29	38	1	0,5	2 600	0,47	NUTR 30 A
	30	28	29	38	1	0,5	2 200	0,47	PWTR 30.2RS
72	30	28	29	38	1	0,5	2 600	0,70	NUTR 3072 A
	30	28	29	38	1	0,5	2 200	0,70	PWTR 3072.2RS
	35	28	29	58	1,1	–	1 000	0,64	NATR 35 PP
	35	28	29	58	1,1	–	1 000	0,55	NATR 35 PPA
	35	28	29	58	1,1	–	750	0,65	NATV 35 PP
	35	28	29	58	1,1	–	750	0,63	NATV 35 PPA
	35	28	29	44	1,1	0,6	2 600	0,63	NUTR 35 A
	35	28	29	44	1,1	0,6	1 800	0,63	PWTR 35.2RS
80	35	28	29	44	1,1	0,6	2 100	0,84	NUTR 3580 A
	35	28	29	44	1,1	0,6	1 800	0,84	PWTR 3580.2RS
	40	30	32	66	1,1	–	850	0,81	NATR 40 PP
	40	30	32	66	1,1	–	850	0,80	NATR 40 PPA
	40	30	32	66	1,1	–	650	0,89	NATV 40 PP
	40	30	32	66	1,1	–	650	0,83	NATV 40 PPA
	40	30	32	51	1,1	0,6	1 600	0,82	NUTR 40 A
	40	30	32	51	1,1	0,6	1 500	0,82	PWTR 40.2RS

¹⁾ All support rollers of the PP design (designation printed in grey) will be gradually replaced by the PPA design

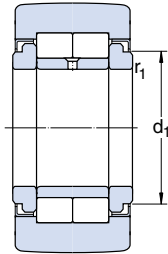

Series NUTR..A

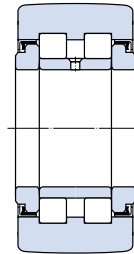

Series PWTR.2RS

Designation ¹⁾	Basic load ratings		Fatigue load limits P_u	Maximum radial forces	
	dynamic C	static C_0		dynamic F_r	static F_{0r}
–	N		N	N	
NUTR 2052 A	31 900	39 000	4 550	30 000	42 500
PWTR 2052.2RS	25 500	29 000	3 350	30 500	44 000
NATR 25	14 700	25 500	3 100	21 600	31 000
NATR 25 PP	14 700	25 500	3 100	21 600	31 000
NATR 25 PPA	14 700	25 500	3 100	21 600	31 000
NATV 25	19 800	44 000	5 300	28 500	40 500
NATV 25 PP	19 800	44 000	5 300	28 500	40 500
NATV 25 PPA	19 800	44 000	5 300	28 500	40 500
NUTR 25 A	29 700	36 000	4 250	18 000	25 500
PWTR 25.2RS	23 800	26 500	3 050	18 600	26 500
NUTR 2562 A	35 800	48 000	5 600	44 000	63 000
PWTR 2562.2RS	29 200	36 000	4 050	45 000	64 000
NATR 30	22 900	37 500	4 550	26 500	38 000
NATR 30 PP	22 900	37 500	4 550	26 500	38 000
NATR 30 PPA	22 900	37 500	4 550	26 500	38 000
NATV 30	29 200	62 000	7 650	34 500	49 000
NATV 30 PP	29 200	62 000	7 650	34 500	49 000
NATV 30 PPA	29 200	62 000	7 650	34 500	49 000
NUTR 30 A	41 300	47 500	5 850	24 000	34 500
PWTR 30.2RS	31 900	32 500	4 050	20 400	29 000
NUTR 3072 A	48 400	61 000	7 500	53 000	76 500
PWTR 3072.2RS	39 600	45 000	5 600	47 500	68 000
NATR 35 PP	24 600	43 000	5 300	33 500	48 000
NATR 35 PPA	24 600	43 000	5 300	33 500	48 000
NATV 35 PP	31 900	72 000	8 800	43 000	62 000
NATV 35 PPA	31 900	72 000	8 800	43 000	62 000
NUTR 35 A	45 700	57 000	6 950	33 500	47 500
PWTR 35.2RS	35 800	40 500	5 000	28 000	40 000
NUTR 3580 A	51 200	68 000	8 300	57 000	81 500
PWTR 3580.2RS	41 800	50 000	6 300	51 000	72 000
NATR 40 PP	31 900	57 000	7 100	41 500	58 500
NATR 40 PPA	31 900	57 000	7 100	41 500	58 500
NATV 40 PP	39 100	88 000	11 000	51 000	73 500
NATV 40 PPA	39 100	88 000	11 000	51 000	73 500
NUTR 40 A	57 200	72 000	9 000	32 000	45 500
PWTR 40.2RS	41 800	49 000	6 000	33 500	48 000

¹⁾ All support rollers of the PP design (designation printed in grey) will be gradually replaced by the PPA design



Support rollers with axial guidance

D 85 – 310 mm

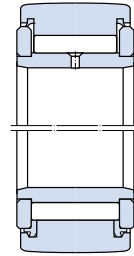
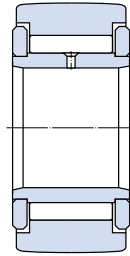
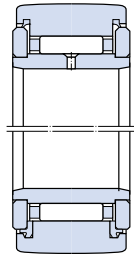
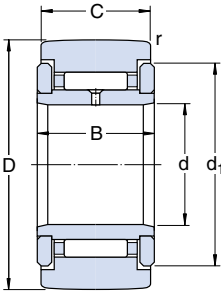

Series NATR

Series NATR .. PP
Series NATR .. PPA

Series NATV

Series NATV .. PP
Series NATV .. PPA

Dimensions					Speed rating	Mass	Designation ¹⁾		
D	C	B	d	d ₁	r min	r ₁ min	r/min	kg	-
mm									
85	45	30	32	55	1,1	0,6	1 400	0,88	NUTR 45 A
	45	30	32	55	1,1	0,6	1 300	0,88	PWTR 45.2RS
90	40	30	32	51	1,1	0,6	1 600	1,13	NUTR 4090 A
	40	30	32	51	1,1	0,6	1 500	1,13	PWTR 4090.2RS
	50	30	32	76	1,1	-	650	0,96	NATR 50 PP
	50	30	32	76	1,1	-	650	0,87	NATR 50 PPA
	50	30	32	76	1,1	-	550	0,99	NATV 50 PP
	50	30	32	76	1,1	-	550	0,97	NATV 50 PPA
	50	30	32	60	1,1	0,6	1 300	0,95	NUTR 50 A
	50	30	32	60	1,1	0,6	1 100	0,95	PWTR 50.2RS
100	45	30	32	55	1,1	0,6	1 400	1,40	NUTR 45100 A
	45	30	32	55	1,1	0,6	1 300	1,40	PWTR 45100.2RS
110	50	30	32	60	1,1	0,6	1 300	1,70	NUTR 50110 A
	50	30	32	60	1,1	0,6	1 100	1,70	PWTR 50110.2RS
130	50	63	65	63	3	2	1 100	5,20	NNTR 50×130×65.2ZL
140	55	68	70	73	3	2	850	6,40	NNTR 55×140×70.2ZL
150	60	73	75	78	3	2	800	7,80	NNTR 60×150×75.2ZL
160	65	73	75	82	3	2	700	8,80	NNTR 65×160×75.2ZL
180	70	83	85	92	3	2	600	13,0	NNTR 70×180×85.2ZL
200	80	88	90	102	4	2	500	17,0	NNTR 80×200×90.2ZL
220	90	98	100	119	4	2,5	400	22,5	NNTR 90×220×100.2ZL
240	100	103	105	132	4	2,5	340	28,0	NNTR 100×240×105.2ZL
260	110	113	115	143	4	2,5	300	35,5	NNTR 110×260×115.2ZL
290	120	133	135	155	4	3	260	53,0	NNTR 120×290×135.2ZL
310	130	144	146	165	5	3	240	65,0	NNTR 130×310×146.2ZL

¹⁾ All support rollers of the PP design (designation printed in grey) will be gradually replaced by the PPA design

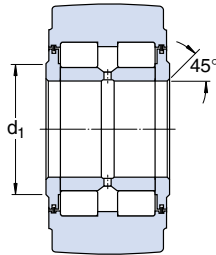
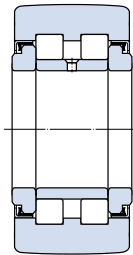
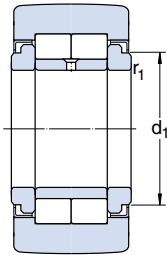

Series NUTR...A

Series PWTR.2RS

Series NNTR.2ZL

Designation ¹⁾	Basic load ratings		Fatigue load limits P _U	Maximum radial forces	
	dynamic C	static C ₀		dynamic F _r	static F _{0r}
–	N		N	N	
NUTR 45 A	58 300	75 000	9 300	32 500	46 500
PWTR 45.2RS	42 900	50 000	6 200	34 000	48 000
NUTR 4090 A	68 200	91 500	11 400	63 000	90 000
PWTR 4090.2RS	49 500	62 000	7 650	64 000	91 500
NATR 50 PP	30 800	58 500	7 200	40 000	57 000
NATR 50 PPA	30 800	58 500	7 200	40 000	57 000
NATV 50 PP	39 100	93 000	11 600	50 000	72 000
NATV 50 PPA	39 100	93 000	11 600	50 000	72 000
NUTR 50 A	58 300	78 000	9 650	32 500	47 500
PWTR 50.2RS	42 900	52 000	6 550	34 500	49 000
NUTR 45100 A	73 700	104 000	12 700	80 000	114 000
PWTR 45100.2RS	53 900	69 500	8 650	81 500	116 000
NUTR 50110 A	78 100	116 000	14 300	98 000	140 000
PWTR 50110.2RS	57 200	78 000	9 650	100 000	143 000
NNTR 50×130×65.2ZL	179 000	232 000	31 000	224 000	320 000
NNTR 55×140×70.2ZL	209 000	275 000	37 500	224 000	320 000
NNTR 60×150×75.2ZL	238 000	320 000	42 500	265 000	375 000
NNTR 65×160×75.2ZL	255 000	345 000	46 500	285 000	405 000
NNTR 70×180×85.2ZL	330 000	455 000	61 000	375 000	540 000
NNTR 80×200×90.2ZL	391 000	540 000	71 000	455 000	640 000
NNTR 90×220×100.2ZL	468 000	670 000	83 000	480 000	680 000
NNTR 100×240×105.2ZL	528 000	780 000	93 000	550 000	780 000
NNTR 110×260×115.2ZL	627 000	930 000	112 000	655 000	950 000
NNTR 120×290×135.2ZL	825 000	1 270 000	143 000	900 000	1 290 000
NNTR 130×310×146.2ZL	952 000	1 460 000	166 000	1 040 000	1 500 000

¹⁾ All support rollers of the PP design (designation printed in grey) will be gradually replaced by the PPA design





Cam followers

Product tables page 192

Cam followers are essentially needle or cylindrical roller bearings with a thick-walled outer ring. The outside surface of the outer ring is crowned which serves to prevent edge stresses if the cam follower runs in a tilted or inclined position. Cam followers are ready-to-mount units which are filled with grease. They are suitable for all types of cam drives, tracks and conveyor systems etc.

Instead of an inner ring cam followers have a solid stud (pin) which is threaded so that the cam follower can be quickly and easily attached to appropriate machine components by means of a hexagonal nut. Axial guidance for the outer ring is provided by an integral flange at the head of the stud

and a side washer or flange ring pressed on to the stud, or by the roller complement.

SKF cam followers are available in three different designs which have the same dimensions and differ only in their internal design. Generally, the cam followers have a concentric seating on the stud (→ **fig 1**), but some are also available with an eccentric collar which is shrunk on to the stud (→ **fig 2**). Cam followers with eccentric collar enable an optimum interaction with the cam to be obtained and also allow less stringent manufacturing tolerances to be used for the associated components.

3

Fig 1

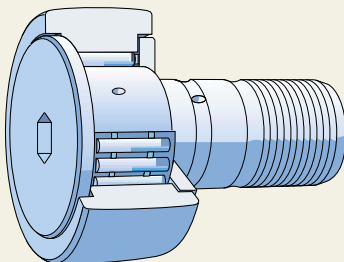
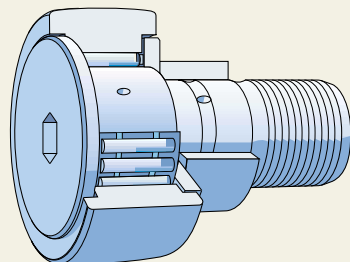

Fig 2



Cam followers

Cam followers of the KR design

KR cam followers (→ fig 1, page 181) are fitted with needle rollers. This allows for a very thick-walled outer ring so that heavy and also shock loads can be supported. Axial guidance is achieved via the integral flange on the stud and a pressed on side washer. With the exception of a few sizes of the basic design, which are available with or without seals, the cam followers are produced as standard fitted with rubbing seals.

Sealed KR cam followers of the

- PP design (→ fig 3) and PPB design (→ fig 4) have seals of nitrile rubber (NBR) or polyurethane at both sides and are suitable for operating temperatures from -30 to $+100$ °C.
- PPA design (→ fig 5) have sliding thrust washers of polyamide 6,6. These reduce the sliding friction between the outer ring and side washer or flange and allow a reduction in the running temperature of the cam follower; this is favourable with regard to the service life of the grease. The sliding washer has the form of a cup spring with a sealing lip and acts as an axial seal which reliably retains the grease. In the radial direction a narrow labyrinth is formed with the outer ring which excludes coarse contaminants. The permissible operating temperature range for the sealed cam followers is -30 to $+100$ °C.

KR cam followers of the PPA design are being gradually introduced to replace the PP and PPB designs which will no longer be produced.

All cam followers of the PPA design have an enhanced runner profile (outside diameter of outer ring). The new design allows a more favourable distribution of stress than the crowned profile of the earlier design, even when running in a tilted position. This leads to higher stiffness and less wear between the runner surface and its counterface.

Fig 3

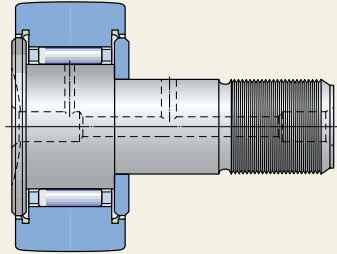

Fig 4

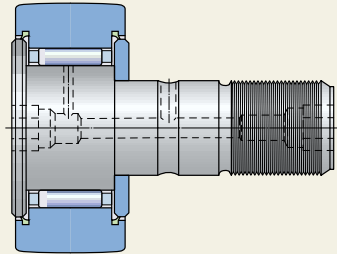
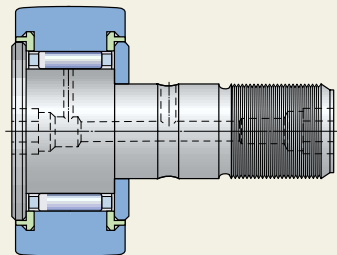

Fig 5



Basic design, series KR

Cam followers of series KR (→ **fig 1**, **page 181**) have a cage-guided roller complement. The cage is of steel and guides the rollers along their whole length, making relatively high speed operation possible.

The head of the stud of sizes 16 and 19 (→ **fig 6**) has a slot and a lubrication hole to take a grease nipple. They may also be supplied with an internal hexagon in the head instead. Such cam followers are identified by the suffix SK and cannot be relubricated.

Cam followers of size 22 and larger of the B, PPA and PPB designs have an internal hexagon at the head and threaded ends of the stud for use when mounting (→ **figs 4** and **5**). The other designs have a slot (→ **fig 3**). All sizes from size 22 have lubrication holes at both ends to take grease nipples. Appropriate grease nipples are supplied with the cam followers. Other grease nipples should not be used.

From size 35, the lubrication holes are also suitable to take adapters for connection to centralised lubrication systems. More details will be found under the heading “Accessories” on **page 186**.

Cam followers with eccentric collar, series KRE

The design of these cam followers is the same as the basic design except that they have a shrunk-on eccentric collar (→ **fig 7**). They can only be relubricated through the ends of the stud.

Full complement cam followers, series KRV

These cam followers incorporate the maximum number of needle rollers (→ **fig 8**) and can therefore support very heavy loads. Because of the special kinematic conditions, however, they cannot operate at such high speeds as the KR cam followers. More frequent relubrication is also required.

Fig 6

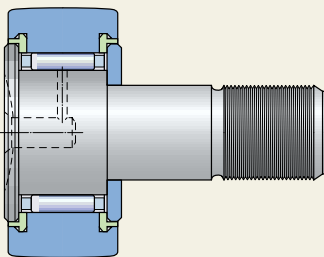

Fig 7

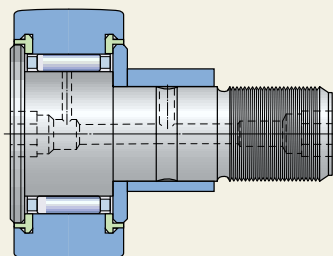
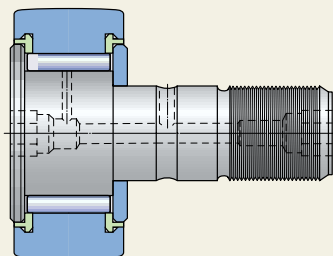

Fig 8



Cam followers

Cam followers of the NUKR design

Cam followers of the NUKR design (→ **fig 9**) are based on double row full complement cylindrical roller bearings. The outer ring has two integral flanges which axially guide the roller complement. The stud head and a flange ring which is pressed on to the stud shank guide the outer ring axially via the rollers. Sheet metal angle rings which are pressed into the outer ring and extend over the stud head and the flange ring provide efficient labyrinth seals.

The NUKR cam followers are suitable for heavy radial loads and, as the outer ring is axially guided by the rollers, they can also support heavy axial loads. They also permit relatively high speed operation. However, because of the full complement of rollers they require frequent relubrication. Grease can be supplied through the ends of the stud or through the lubrication hole in the stud shank.

The cam followers of the NUKRE design have an eccentric collar which is shrunk on to the stud (→ **fig 10**). As the collar covers the lubrication hole in the shank, these cam followers can only be relubricated via the ends of the stud.

Cam followers of the NUKR(E) design have an internal hexagon at the head and threaded ends which can be used for holding the cam follower during mounting. The lubrication holes at both ends are designed to take a grease nipple or an adapter for connection to a centralised lubrication system (→ “Accessories”, **page 186**). To differentiate from an earlier design which had a groove instead of the internal hexagon in the head and which could only take a grease nipple and not an adapter, these newer cam followers are identified by suffix A in the designation during a transition period, e.g. NUKR(E) 47 A.

The cam followers identified by suffix A have an enhanced runner profile (outside diameter of outer ring). The new design allows a more favourable distribution of stress than the crowned profile of the earlier design, even when running in a tilted position. This leads to higher stiffness and less wear between the runner surface and its counterface.

Fig 9

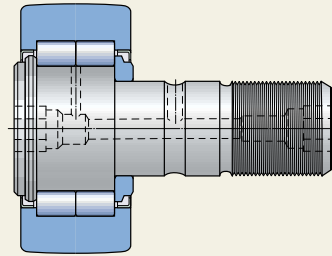
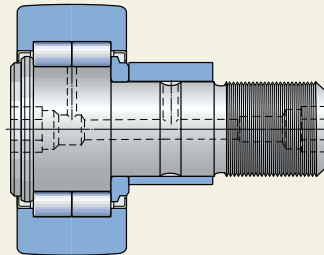

Fig 10



Cam followers of the PWKR design

These cam followers (→ **fig 11**) are fitted with rubbing seals (designation suffix .2RS) and are therefore particularly suitable for operation under arduous conditions. The outer ring has three integral flanges which provide axial guidance separately for the two rows of rollers (full complement). The stud head and a flange ring which is pressed on to the stud shank guide the outer ring axially via the rollers. The separate guidance of the two rows of rollers reduces the friction and thus heat generation. These cam followers are therefore suitable for the accommodation of heavy and even constantly acting axial loads such as are produced when the cam followers operate in an inclined position.

The particular characteristics of these cam followers are their seals and the large space between the roller rows. Sheet metal angle rings which are pressed into the outer ring serve as secondary seals. The primary seals consist of sealing lips of oil and wear-resistant nitrile rubber (NBR). The lips are vulcanised to the inside of the angle rings and exert a light pressure on the head and flange ring. These sealing lips greatly enhance the sealing efficiency both outwards and inwards. The large space between the two roller rows means that a large quantity of grease can be incorporated. The seals and grease limit the permissible operating temperature range to -25 to $+120$ °C.

Cam followers of the PWKR.2RS design can be operated for long periods without relubrication even where conditions are difficult. Relubrication is simple and can be accomplished via the holes at the head and threaded ends of the stud. These will take grease nipples or adapters for connection to centralised lubrication systems (→ “Accessories”, **page 186**)

Cam followers of the PWKRE.2RS design have a shrunk on eccentric collar (→ **fig 12**). As this covers the lubrication hole in the shank, it is only possible to relubricate through the stud ends.

Fig 11

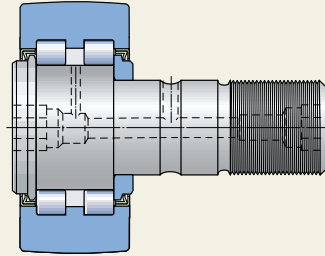
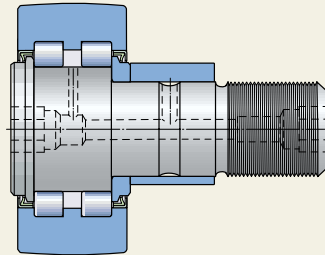

Fig 12



Cam followers

Accessories

These accessories are intended to ensure reliable lubrication and location of the cam followers. Some of the accessories are supplied with the cam followers (→ **Table 1**) whilst others must be ordered separately.

Grease nipples

Grease nipples with cylindrical shank are supplied loose with the cam followers and

must be inserted as required. Dimensions are given in **Table 2**.

Plugs

The end of the relubrication duct in the shank of KR cam followers not required for relubrication should be plugged. The plug should be pressed into place using a mandrel (→ **Table 3**).

Table 1

Accessories for cam followers



Grease nipple



Plug

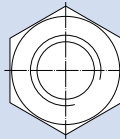

Hexagonal nut

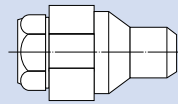

Adapter

Cam follower Design	Supplied with cam follower		To be ordered separately			
	Size without seals	with seals	Grease nipple	Plug	Hexagonal nut	Adapter
KR	16	16 PP/A	NIP A1	VD1	M 6×1	–
KRE	–	16 PPSK/A	–	–	M 6×1	–
KRV	19	19 PP/A	NIP A1	VD1	M 8×1,25	–
–	–	19 PPSK/A	–	–	M 8×1,25	–
–	22	22 PP	1 × NIP A1	VD1	M 10×1	–
22 B	22	22 PPA	2 × NIP A1×4,5	–	M 10×1	–
26	26	26 PP	1 × NIP A1	VD1	M 10×1	–
26 B	26	26 PPA	2 × NIP A1×4,5	–	M 10×1	–
30	30	30 PP	1 × NIP A2	VD2	M 12×1,5	–
30 B	30	30 PPA	2 × NIP A1×4,5	–	M 12×1,5	–
32	32	32 PP	1 × NIP A2	VD2	M 12×1,5	–
32 B	32	32 PPA	2 × NIP A1×4,5	–	M 12×1,5	–
35	35	35 PP	1 × NIP A2	VD2	M 16×1,5	–
35 B	35	35 PPA	2 × NIP A2×7,5	–	M 16×1,5	AP 8
40	40	40 PP	1 × NIP A2	VD2	M 18×1,5	–
40 B	40	40 PPA	2 × NIP A2×7,5	–	M 18×1,5	AP 8
–	–	47 PP	1 × NIP A3	VD3	M 20×1,5	–
–	–	47 PPA	2 × NIP A2×7,5	–	M 20×1,5	AP 10
–	–	52 PP	1 × NIP A3	VD3	M 20×1,5	–
–	–	52 PPA	2 × NIP A2×7,5	–	M 20×1,5	AP 10
–	–	62 PPA/B	2 × NIP A3×9,5	–	M 24×1,5	AP 14
–	–	72 PPA/B	2 × NIP A3×9,5	–	M 24×1,5	AP 14
–	–	80 PPA/B	2 × NIP A3×9,5	–	M 30×1,5	AP 14
–	–	90 PPA/B	2 × NIP A3×9,5	–	M 30×1,5	AP 14
NUKR	–	35	2 × NIP A2×7,5	–	M 16×1,5	AP 8
NUKRE	–	40	2 × NIP A2×7,5	–	M 18×1,5	AP 8
PWKR	–	47	2 × NIP A2×7,5	–	M 20×1,5	AP 10
PWKRE	–	52	2 × NIP A2×7,5	–	M 20×1,5	AP 10
–	–	62	2 × NIP A3×9,5	–	M 24×1,5	AP 14
–	–	72	2 × NIP A3×9,5	–	M 24×1,5	AP 14
–	–	80	2 × NIP A3×9,5	–	M 30×1,5	AP 14
–	–	90	2 × NIP A3×9,5	–	M 30×1,5	AP 14

Hexagonal nuts

Hexagonal nuts to ISO 4032:1986 or ISO 8673:1988, for the attachment of cam followers to the appropriate components, are also supplied loose with each cam follower. The nuts are of strength class 8.8 and are zinc galvanised to ISO 4042:1989. The dimensions and recommended tightening torques are given in **Table 4**.

Table 3

Plugs

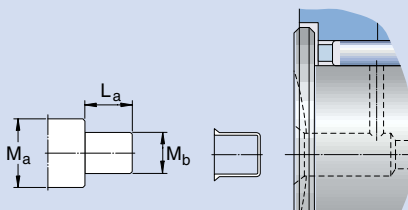

Plug Designation	Nominal diameter	Mandrel Dimensions		
		M_a	M_b	L_a
-	mm			
VD1	4	10	2,7	5,2
VD2	6	12	4,7	7,3
VD3	8	15	6,7	10

Table 2

Grease nipples

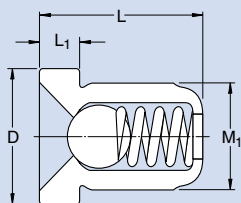

Designation	Dimensions			
	M_1	D	L	L_1
-	mm			
NIP A1	4	6	6	1,5
NIP A1×4,5	4	4,7	4,5	1
NIP A2	6	8	9	2
NIP A2×7,5	6	7,5	7,5	2
NIP A3	8	10	12	3
NIP A3×9,5	8	10	9,5	3

Table 4

Hexagonal nuts

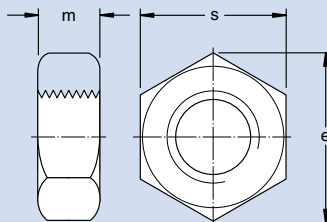

Size	Dimensions			Tightening torque	Standard ¹⁾
	m	e	s		
-	mm			Nm	-
M 6×1	5,2	11	10	3	1
M 8×1,25	6,8	14,4	13	8	1
M 10×1	8,4	17,8	16	15	2
M 12×1,5	10,8	20	18	22	2
M 16×1,5	14,8	26,8	24	58	2
M 18×1,5	15,8	29,6	27	87	2
M 20×1,5	18	33	30	120	2
M 24×1,5	21,5	39,5	36	220	2
M 30×1,5	25,6	50,9	46	450	2

¹⁾ ISO 4032:1986
ISO 8673:1988

Cam followers

Adapters for connection to centralised lubrication system

Adapters of type AP are intended to enable cam followers to be relubricated via a centralised lubrication system. They consist of a connection and a quick closure which will take, for example, polyamide tubing 4x0,75 to DIN 73378:1996 (→ fig 13). The designs and dimensions are given in Table 5.

Table 5

Adapters

Design 1

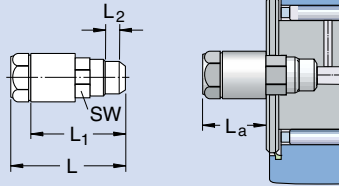

Design 2

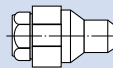

Designation	Dimensions				
	L	L ₁	L ₂	L _a	SW
–	mm				
AP 8	27	22	4	16	8
AP 10	27	22	5	15	10
AP 14	25	20	6	8	14

Fig 13

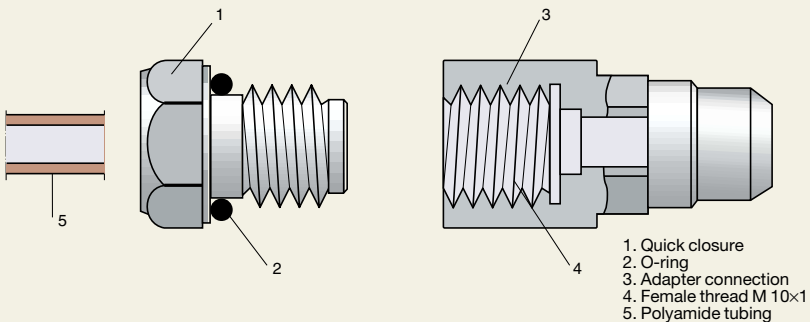

Dimensions

The dimensions of the cam followers conform to ISO 6278-1980 and, where standardised to ANSI/AFBMA Standard 18.1-1976.

Tolerances

SKF cam rollers are produced to Normal tolerances to ISO 492:1994 (→ **Table 2**, **page 17**) except for

- the tolerance of the profiled outside diameter which is $0/-0,050$ mm,
- the shank diameter tolerance which is h7, and
- the eccentric diameter tolerance which is h9.

The limits for tolerances h7 and h9 will be found in **Table 6**.

Internal clearance

SKF cam followers have a radial internal clearance in the C2 range for cylindrical and needle roller bearings corresponding to class 2 according to ISO 5793:1991. The values are given in **Table 6**, **page 21**.

Load carrying capacity

In contrast to normal roller bearings, where the outer ring is supported over its entire surface in the bore of a housing, the outer ring of a cam follower only has a small area of contact with the surface against which it runs. The deformation of the outer ring caused by this limited contact alters the force distribution in the bearing and thus has an influence on life and load carrying capacity. The basic load ratings given in the product tables take this influence into account.

The ability to carry dynamic loads depends on the requisite life, but it is important with reference to the strength of the outer ring that the value of the maximum dynamic radial load F_r is not exceeded.

The permissible static load for a cam follower is determined by the smaller of the values of F_{0r} and C_0 . If requirements regarding smooth running are small, the static load may exceed C_0 but should never exceed the maximum permissible static radial load F_{0r} .

Table 6

ISO tolerances					
Nominal dimension over incl.		h7 Deviations high low		h9 Deviations high low	
mm		µm		µm	
3	6	0	-12	0	-30
6	10	0	-15	0	-36
10	18	0	-18	0	-43
18	30	0	-21	0	-52
30	50	0	-25	0	-62

Fig 14

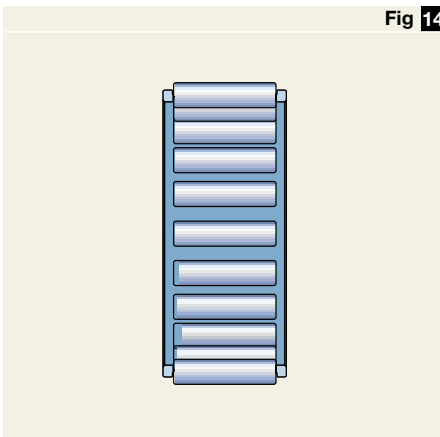

Cages

The cages of cam followers of the KR design are made of steel (→ **fig 14**).

Cam followers

Lubrication

All cam followers are supplied as standard filled with a high-quality lithium base grease of NLGI class 2 consistency. The grease is based on mineral oil and has good rust inhibiting properties. It has an operating temperature range of -25 to $+150$ °C.

SKF cam followers require little maintenance. To exploit their full service life, they must, however, be relubricated. This can be done through ducts in the stud (→ **fig 15**)

- from the head (1) side (bearing end),
- from the threaded end (2), and
- through the shank (3)

except for the following:

- cam followers KR 16 and KR 19, which can only be relubricated via the head;
- cam followers KR 16 and KR 19 in the PPSK and PPSKA designs which cannot be relubricated;
- cam followers with eccentric collar; the collar covers the relubrication hole in the stud shank so that they can only be relubricated via the stud ends.

Relubrication should preferably be undertaken while the first grease fill still has its full lubricating properties. Generally, where loads are light, speeds relatively low and the surroundings clean, cam followers can operate for long periods without relubrication. If, however, the environment is contaminated and damp, or if they operate for long periods at high speeds or temperatures higher than $+70$ °C, they must be relubricated frequently.

For relubrication it is recommended that SKF grease be used – grease LGMT 2 or preferably LGWA 2. This is a lithium complex grease with a mineral oil base and has good rust inhibiting properties.

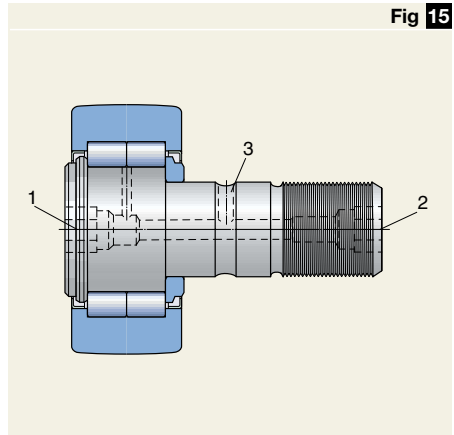
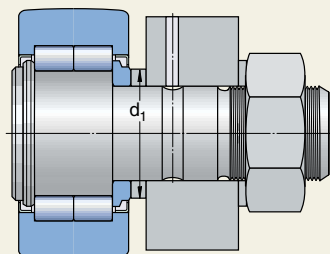

Fig 16



Design of associated components

The side washers and flange rings which are pressed on to the stud shank should, where possible, be supported over their entire face. It is therefore recommended that the support surface should have a diameter corresponding to the dimension d_1 (→ fig 16). The bore to take the stud should be machined to tolerance H7. For cam followers which are subjected to shock loads, the stud should preferably be mounted without clearance in its bore. It is also recommended that recommended torques given in **Table 4** on **page 187** for tightening the nuts be respected. If the requisite tightening torque cannot be achieved, the stud should be mounted with an interference fit.

Mounting instructions

Cam followers can be attached to associated components using conventional hexagonal nuts (→ fig 16). Appropriate nuts as shown in **Table 1** on **page 186** are supplied with each cam follower. To lock them, spring washers, for example to DIN 128:1994 are adequate.

It is recommended that the nuts be tightened to the torques quoted in **Table 4** on **page 187**. Only then will the full load carrying potential of the cam followers be available. A suitable tool can be inserted in the groove or internal hexagon at the head or threaded end of the stud to hold it while the nut is being tightened.

Depending on the mounting conditions, cam followers with eccentric collar can be adjusted to the required eccentricity via the groove or internal hexagon.

Blows to the head of the stud should be avoided. Care should also be taken to see that the lubrication hole lies in the unloaded zone. The position of this hole corresponds to the trademark on the stud head. The lubrication hole in the stud shank lies in the same direction and can be used for cam followers without eccentric collar either for relubrication purposes or for a locking device to prevent the stud from turning.

Cam followers D 16–22 mm

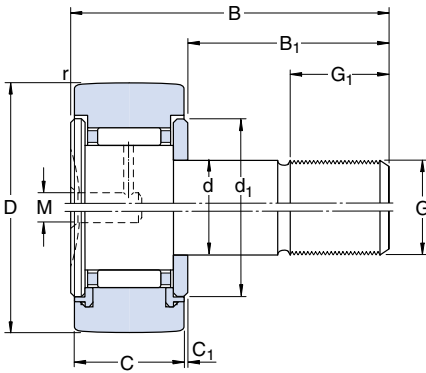

Series KR 16, KR 19
Series KR 16 PPA, KR 19 PPA

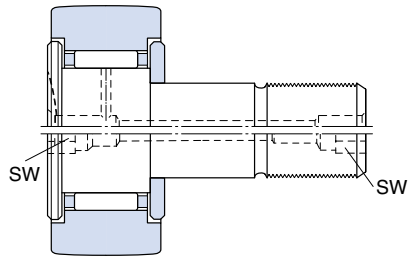

Series KR 22
Series KR 22 B

Dimensions													Mass	Designation ¹⁾		
Cam follower																
D	C	d	B	B ₁	C ₁	d ₁	G	G ₁	M	r	min	SW	Eccentric collar c	B ₃	kg	–
mm													kg	–		
16	11	6	28	16	0,6	12,5	M6	8	4	0,15	–	–	–	–	0,019	KR 16
	11	6	28	16	0,6	12	M6	8	4	0,15	–	–	–	–	0,018	KR 16 PP
	11	6	28	16	0,6	12,5	M6	8	4	0,15	–	–	–	–	0,018	KR 16 PPA
	11	6	28	16	0,6	12,5	M6	8	–	0,15	4	–	–	–	0,019	KR 16 PPSK ²⁾
	11	6	28	16	0,6	12,5	M6	8	–	0,15	4	–	–	–	0,019	KR 16 PPSKA²⁾
	11	6	28	16	0,6	12	M6	8	4	0,15	–	–	–	–	0,020	KR 16 PP
	11	6	28	16	0,6	12,5	M6	8	4	0,15	–	–	–	–	0,019	KRV 16 PPA
	11	9	28	16	0,6	12	M6	8	4	0,15	–	0,5	7	–	0,020	KRE 16 PP
	11	9	28	16	0,6	12,5	M6	8	4	0,15	–	0,5	7	–	0,020	KRE 16 PPA
	19	11	8	32	20	0,6	15	M8	10	4	0,15	–	–	–	–	0,029
11		8	32	20	0,6	14	M8	10	4	0,15	–	–	–	–	0,028	KR 19 PP
11		8	32	20	0,6	15	M8	10	4	0,15	–	–	–	–	0,029	KR 19 PPA
11		8	32	20	0,6	15	M8	10	–	0,15	4	–	–	–	0,029	KR 19 PPSK ²⁾
11		8	32	20	0,6	15	M8	10	–	0,15	4	–	–	–	0,029	KR 19 PPSKA²⁾
11		8	32	20	0,6	14	M8	10	4	0,15	–	–	–	–	0,032	KR 19 PP
11		8	32	20	0,6	15	M8	10	4	0,15	–	–	–	–	0,031	KRV 19 PPA
11		11	32	20	0,6	14	M8	10	4	0,15	–	0,5	9	–	0,031	KRE 19 PP
11		11	32	20	0,6	15	M8	10	4	0,15	–	0,5	9	–	0,032	KRE 19 PPA
22		12	10	36	23	0,6	17	M10×1	12	4	0,3	–	–	–	–	0,044
	12	10	36	23	0,6	17,5	M10×1	12	–	0,3	5	–	–	–	0,045	KR 22 B
	12	10	36	23	0,6	17	M10×1	12	4	0,3	–	–	–	–	0,044	KR 22 PP
	12	10	36	23	0,6	17,5	M10×1	12	–	0,3	5	–	–	–	0,043	KR 22 PPA
	12	10	36	23	0,6	17	M10×1	12	4	0,3	–	–	–	–	0,045	KR 22 PP
	12	10	36	23	0,6	17,5	M10×1	12	–	0,3	5	–	–	–	0,045	KRV 22 PPA
	12	13	36	23	0,6	17	M10×1	12	4	0,3	–	0,5	10	–	0,048	KRE 22 PP
	12	13	36	23	0,6	17,5	M10×1	12	–	0,3	5	0,5	10	–	0,047	KRE 22 PPA

¹⁾ All cam followers of the KR design where the designation is printed in grey are gradually being replaced by more robust designs

²⁾ Internal hexagon in the stud head only; cannot be relubricated

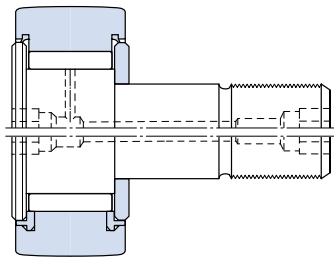

Series KRV 22 PP
Series KRV 22 PPA

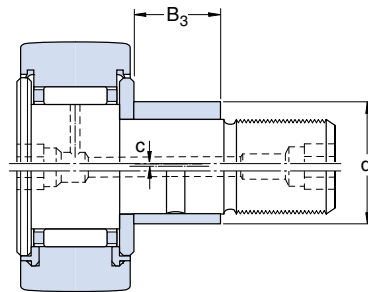

Series KRE 22 PP
Series KRE 22 PPA

Designation ¹⁾	Basic load ratings		Fatigue load limit P_u	Maximum radial forces		Speed rating
	dynamic C	static C_0		dynamic F_r	static F_{0r}	
–	N		N	N		r/min
KR 16	3 140	3 200	345	2 900	4 150	14 000
KR 16 PP	3 140	3 200	345	2 900	4 150	14 000
KR 16 PPA	3 140	3 200	345	2 900	4 150	14 000
KR 16 PPSK	3 140	3 200	345	2 900	4 150	14 000
KR 16 PPSKA	3 140	3 200	345	2 900	4 150	14 000
KRV 16 PP	4 730	6 550	720	4 050	5 700	3 800
KRV 16 PPA	4 730	6 550	720	4 050	5 700	3 800
KRE 16 PP	3 140	3 200	345	2 900	4 150	14 000
KRE 16 PPA	3 140	3 200	345	2 900	4 150	14 000
KR 19	3 470	3 800	415	3 800	5 500	11 000
KR 19 PP	3 470	3 800	415	3 800	5 500	11 000
KR 19 PPA	3 470	3 800	415	3 800	5 500	11 000
KR 19 PPSK	3 470	3 800	415	3 800	5 500	11 000
KR 19 PPSKA	3 470	3 800	415	3 800	5 500	11 000
KRV 19 PP	5 280	8 000	880	5 100	7 350	3 100
KRV 19 PPA	5 280	8 000	880	5 100	7 350	3 100
KRE 19 PP	3 470	3 800	415	3 800	5 500	11 000
KRE 19 PPA	3 470	3 800	415	3 800	5 500	11 000
KR 22	4 400	5 000	560	4 250	6 000	8 000
KR 22 B	4 400	5 000	560	4 250	6 000	8 000
KR 22 PP	4 400	5 000	560	4 250	6 000	8 000
KR 22 PPA	4 400	5 000	560	4 250	6 000	8 000
KRV 22 PP	6 050	9 150	1 040	5 700	8 150	2 600
KRV 22 PPA	6 050	9 150	1 040	5 700	8 150	2 600
KRE 22 PP	4 400	5 000	560	4 250	6 000	8 000
KRE 22 PPA	4 400	5 000	560	4 250	6 000	8 000

¹⁾ All cam followers of the KR design where the designation is printed in grey are gradually being replaced by more robust designs



Cam followers D 26 – 32 mm

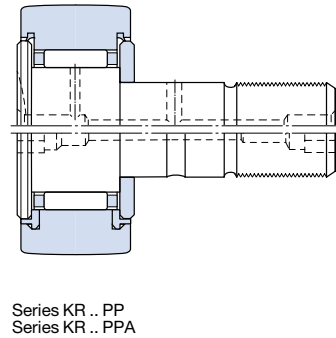
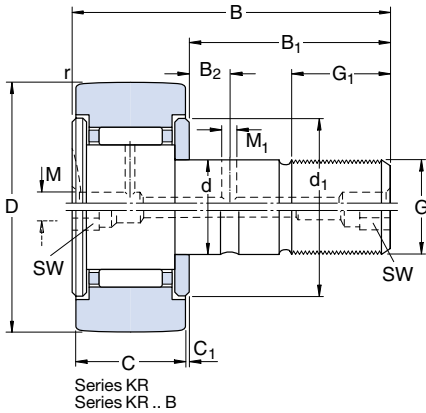

Dimensions Cam follower

D	C	d	B	B ₁	B ₂	C ₁	d ₁	G	G ₁	M	M ₁	r min	SW	Eccentric collar c B ₃		Mass kg	Designation ¹⁾	
mm																	kg	-
26	12	10	36	23	-	0,6	17	M 10×1	12	4	-	0,3	-	-	-	0,058	KR 26	
	12	10	36	23	-	0,6	17,5	M 10×1	12	-	-	0,3	5	-	-	0,059	KR 26 B	
	12	10	36	23	-	0,6	17	M 10×1	12	4	-	0,3	-	-	-	0,058	KR 26 PP	
	12	10	36	23	-	0,6	17,5	M 10×1	12	-	-	0,3	5	-	-	0,057	KR 26 PPA	
	12	10	36	23	-	0,6	17	M 10×1	12	4	-	0,3	-	-	-	0,061	KRV 26 PP	
	12	10	36	23	-	0,6	17,5	M 10×1	12	-	-	0,3	5	-	-	0,059	KRV 26 PPA	
	12	13	36	23	-	0,6	17	M 10×1	12	4	-	0,3	-	0,5	10	0,062	KRE 26 PP	
	12	13	36	23	-	0,6	17,5	M 10×1	12	-	-	0,3	5	0,5	10	0,062	KRE 26 PPA	
	30	14	12	40	25	6	0,6	23	M 12×1,5	13	6	3	0,6	-	-	-	0,087	KR 30
		14	12	40	25	6	0,6	23	M 12×1,5	13	-	3	0,6	6	-	-	0,092	KR 30 B
14		12	40	25	6	0,6	23	M 12×1,5	13	6	3	0,6	-	-	-	0,087	KR 30 PP	
14		12	40	25	6	0,6	23	M 12×1,5	13	-	3	0,6	6	-	-	0,088	KR 30 PPA	
14		12	40	25	6	0,6	23	M 12×1,5	13	6	3	0,6	-	-	-	0,089	KRV 30 PP	
14		12	40	25	6	0,6	23	M 12×1,5	13	-	3	0,6	6	-	-	0,091	KRV 30 PPA	
14		15	40	25	-	0,6	23	M 12×1,5	13	6	-	0,6	-	0,5	11	0,093	KRE 30 PP	
14		15	40	25	-	0,6	23	M 12×1,5	13	-	-	0,6	6	0,5	11	0,093	KRE 30 PPA	
32		14	12	40	25	6	0,6	23	M 12×1,5	13	6	3	0,6	-	-	-	0,098	KR 32
		14	12	40	25	6	0,6	23	M 12×1,5	13	-	3	0,6	6	-	-	0,10	KR 32 B
	14	12	40	25	6	0,6	23	M 12×1,5	13	6	3	0,6	-	-	-	0,098	KR 32 PP	
	14	12	40	25	6	0,6	23	M 12×1,5	13	-	3	0,6	6	-	-	0,098	KR 32 PPA	
	14	12	40	25	6	0,6	23	M 12×1,5	13	6	3	0,6	-	-	-	0,10	KRV 32 PP	
	14	12	40	25	6	0,6	23	M 12×1,5	13	-	3	0,6	6	-	-	0,10	KRV 32 PPA	
	14	15	40	25	-	0,6	23	M 12×1,5	13	6	-	0,6	-	0,5	11	0,10	KRE 32 PP	
	14	15	40	25	-	0,6	23	M 12×1,5	13	-	-	0,6	6	0,5	11	0,10	KRE 32 PPA	

¹⁾ All cam followers of the KR design where the designation is printed in grey are gradually being replaced by more robust designs

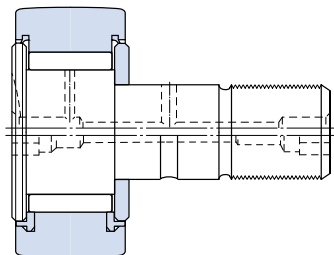

Series KRV .. PP
Series KRV .. PPA

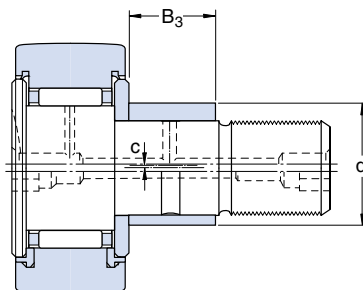

Series KRE .. PP
Series KRE .. PPA

Designation ¹⁾	Basic load ratings		Fatigue load limit P_u	Maximum radial forces		Speed rating
	dynamic C	static C_0		dynamic F_r	static F_{0r}	
–	N		N	N		r/min
KR 26	4 840	6 000	655	9 300	13 200	8 000
KR 26 B	4 840	6 000	655	9 300	13 200	8 000
KR 26 PP	4 840	6 000	655	9 300	13 200	8 000
KR 26 PPA	4 840	6 000	655	9 300	13 200	8 000
KRV 26 PP	6 820	11 000	1 250	11 400	16 300	2 600
KRV 26 PPA	6 820	11 000	1 250	11 400	16 300	2 600
KRE 26 PP	4 840	6 000	655	9 300	13 200	8 000
KRE 26 PPA	4 840	6 000	655	9 300	13 200	8 000
KR 30	6 440	8 000	880	7 800	11 200	5 500
KR 30 B	6 440	8 000	880	7 800	11 200	5 500
KR 30 PP	6 440	8 000	880	7 800	11 200	5 500
KR 30 PPA	6 440	8 000	880	7 800	11 200	5 500
KRV 30 PP	8 970	14 600	1 660	11 000	15 600	2 100
KRV 30 PPA	8 970	14 600	1 660	11 000	15 600	2 100
KRE 30 PP	6 440	8 000	880	7 800	11 200	5 500
KRE 30 PPA	6 440	8 000	880	7 800	11 200	5 500
KR 32	6 710	8 500	950	10 600	15 000	5 500
KR 32 B	6 710	8 500	950	10 600	15 000	5 500
KR 32 PP	6 710	8 500	950	10 600	15 000	5 500
KR 32 PPA	6 710	8 500	950	10 600	15 000	5 500
KRV 32 PP	9 350	15 300	1 760	14 300	20 400	2 100
KRV 32 PPA	9 350	15 300	1 760	14 300	20 400	2 100
KRE 32 PP	6 710	8 500	950	10 600	15 000	1 550
KRE 32 PPA	6 710	8 500	950	10 600	15 000	1 550

¹⁾ All cam followers of the KR design where the designation is printed in grey are gradually being replaced by more robust designs



Cam followers
D 35 – 40 mm

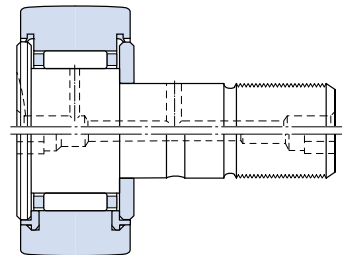
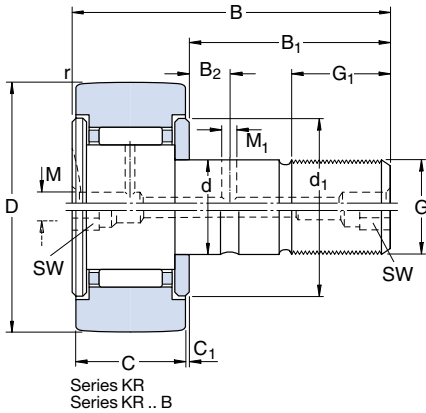

Series KR
Series KR .. B

Series KR .. PP
Series KR .. PPA

Dimensions
Cam follower

D	C	d	B	B ₁	B ₂	C ₁	d ₁	G	G ₁	M	M ₁	r	SW	Eccentric collar		Mass	Designation ¹⁾
													c	B ₃	kg	-	
mm																	
35	18	16	52	32,5	8	0,8	27	M 16×1,5	17	6	3	0,6	-	-	-	0,17	KR 35
	18	16	52	32,5	8	0,8	27,6	M 16×1,5	17	-	3	0,6	8	-	-	0,17	KR 35 B
	18	16	52	32,5	8	0,8	27	M 16×1,5	17	6	3	0,6	-	-	-	0,17	KR 35 PP
	18	16	52	32,5	8	0,8	27,6	M 16×1,5	17	-	3	0,6	8	-	-	0,16	KR 35 PPA
	18	16	52	32,5	8	0,8	27	M 16×1,5	17	6	3	0,6	-	-	-	0,17	KRV 35 PP
	18	16	52	32,5	8	0,8	27,6	M 16×1,5	17	-	3	0,6	8	-	-	0,17	KRV 35 PPA
	18	16	52	32,5	7,8	0,8	20	M 16×1,5	17	-	3	0,6	8	-	-	0,16	NUKR 35 A
	18	16	52	32,5	7,8	0,8	20	M 16×1,5	17	-	3	0,6	8	-	-	0,16	PWKRE 35.2RS
	18	20	52	32,5	-	0,8	27	M 16×1,5	17	6	-	0,6	-	1	14	0,18	KRE 35 PP
	18	20	52	32,5	-	0,8	27,6	M 16×1,5	17	-	-	0,6	8	1	14	0,18	KRE 35 PPA
	18	20	52	29,5	-	3,8	27	M 16×1,5	17	-	-	0,6	8	1	12	0,18	NUKRE 35 A
	18	20	52	29,5	-	3,8	27	M 16×1,5	17	-	-	0,6	8	1	12	0,18	PWKRE 35.2RS
40	20	18	58	36,5	8	0,8	32	M 18×1,5	19	6	3	1	-	-	-	0,25	KR 40
	20	18	58	36,5	8	0,8	31,5	M 18×1,5	19	-	3	1	8	-	-	0,25	KR 40 B
	20	18	58	36,5	8	0,8	32	M 18×1,5	19	6	3	1	-	-	-	0,25	KR 40 PP
	20	18	58	36,5	8	0,8	31,5	M 18×1,5	19	-	3	1	8	-	-	0,25	KR 40 PPA
	20	18	58	36,5	8	0,8	32	M 18×1,5	19	6	3	1	-	-	-	0,25	KRV 40 PP
	20	18	58	36,5	8	0,8	31,5	M 18×1,5	19	-	3	1	8	-	-	0,25	KRV 40 PPA
	20	18	58	36,5	8	0,8	22	M 18×1,5	19	-	3	1	8	-	-	0,24	NUKR 40 A
	20	18	58	36,5	8	0,8	22	M 18×1,5	19	-	3	1	8	-	-	0,24	PWKRE 40.2RS
	20	22	58	36,5	-	0,8	32	M 18×1,5	19	6	-	1	-	1	16	0,26	KRE 40 PP
	20	22	58	36,5	-	0,8	31,5	M 18×1,5	19	-	-	1	8	1	16	0,26	KRE 40 PPA
	20	22	58	33,5	-	3,8	30	M 18×1,5	19	-	-	1	8	1	14	0,26	NUKRE 40 A
	20	22	58	33,5	-	3,8	30	M 18×1,5	19	-	-	1	8	1	14	0,26	PWKRE 40.2RS

¹⁾ All cam followers of the KR design where the designation is printed in grey are gradually being replaced by more robust designs

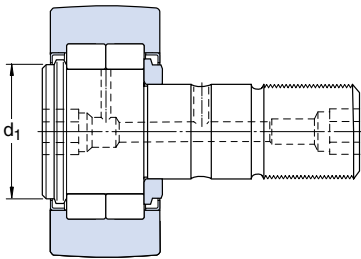

Series NUKR

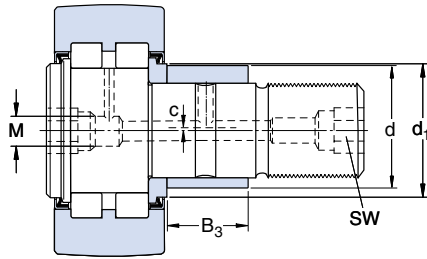

Series PWKRE.2RS

Designation ¹⁾	Basic load ratings		Fatigue load limit P_u	Maximum radial forces		Speed rating
	dynamic C	static C_0		dynamic F_r	static F_{0r}	
–	N		N	N		r/min
KR 35	9 520	13 700	1 560	11 400	16 300	3 600
KR 35 B	9 520	13 700	1 560	11 400	16 300	3 600
KR 35 PP	9 520	13 700	1 560	11 400	16 300	3 600
KR 35 PPA	9 520	13 700	1 560	11 400	16 300	3 600
KRV 35 PP	12 300	23 200	2 700	14 600	20 800	1 600
KRV 35 PPA	12 300	23 200	2 700	14 600	20 800	1 600
NUKR 35 A	16 800	17 600	2 000	8 650	12 200	6 500
PWKRE 35.2RS	11 900	11 400	1 200	8 650	12 500	6 000
KRE 35 PP	9 520	13 700	1 560	11 400	16 300	3 600
KRE 35 PPA	9 520	13 700	1 560	11 400	16 300	3 600
NUKRE 35 A	16 800	17 600	2 000	8 650	12 200	6 500
PWKRE 35.2RS	11 900	11 400	1 200	8 650	12 500	6 000
KR 40	10 500	14 600	1 730	12 500	18 000	2 900
KR 40 B	10 500	14 600	1 730	12 500	18 000	2 900
KR 40 PP	10 500	14 600	1 730	12 500	18 000	2 900
KR 40 PPA	10 500	14 600	1 730	12 500	18 000	2 900
KRV 40 PP	14 200	26 500	3 100	17 000	24 500	1 400
KRV 40 PPA	14 200	26 500	3 100	17 000	24 500	1 400
NUKR 40 A	19 000	22 000	2 500	14 000	20 000	5 500
PWKRE 40.2RS	13 800	14 300	1 500	13 700	19 600	5 000
KRE 40 PP	10 500	14 600	1 730	12 500	18 000	2 900
KRE 40 PPA	10 500	14 600	1 730	12 500	18 000	2 900
NUKRE 40 A	19 000	22 000	2 500	14 000	20 000	5 500
PWKRE 40.2RS	13 800	14 300	1 500	13 700	19 600	5 000

¹⁾ All cam followers of the KR design where the designation is printed in grey are gradually being replaced by more robust designs



Cam followers
D 47 – 62 mm

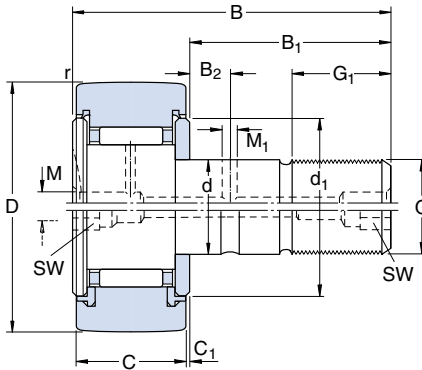

Series KR .. PP
Series KR .. PPA

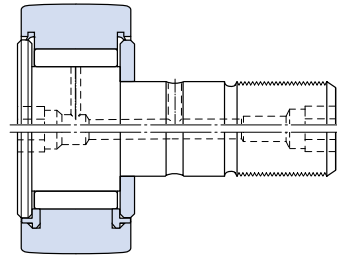

Series KRV .. PPB
Series KRV .. PPA

Dimensions
Cam follower

Dimensions														Mass	Designation ¹⁾		
D	C	d	B	B ₁	B ₂	C ₁	d ₁	G	G ₁	M	M ₁	r	SW	Eccentric collar c B ₃	kg	-	
mm														kg	-		
47	24	20	66	40,5	9	0,8	37	M 20×1,5	21	8	4	1	-	-	0,39	KR 47 PP	
	24	20	66	40,5	9	0,8	36,5	M 20×1,5	21	-	4	1	10	-	0,38	KR 47 PPA	
	24	20	66	40,5	9	0,8	36,5	M 20×1,5	21	8	4	1	-	-	0,39	KRV 47 PP	
	24	20	66	40,5	9	0,8	36,5	M 20×1,5	21	-	4	1	10	-	0,39	KRV 47 PPA	
	24	20	66	40,5	9	0,8	27	M 20×1,5	21	-	4	1	10	-	0,38	NUKR 47 A	
	24	20	66	40,5	9	0,8	27	M 20×1,5	21	-	4	1	10	-	0,38	PWKR 47.2RS	
	24	24	66	40,5	-	0,8	37	M 20×1,5	21	8	-	1	-	1	18	0,41	KRE 47 PP
	24	24	66	40,5	-	0,8	36,5	M 20×1,5	21	-	-	1	10	1	18	0,41	KRE 47 PPA
	24	24	66	40,5	-	0,8	27	M 20×1,5	21	-	-	1	10	1	18	0,40	NUKRE 47 A
	24	24	66	40,5	-	0,8	27	M 20×1,5	21	-	-	1	10	1	18	0,40	PWKRE 47.2RS
52	24	20	66	40,5	9	0,8	37	M 20×1,5	21	8	4	1	-	-	0,46	KR 52 PP	
	24	20	66	40,5	9	0,8	36,5	M 20×1,5	21	-	4	1	10	-	0,45	KR 52 PPA	
	24	20	66	40,5	9	0,8	36,5	M 20×1,5	21	8	4	1	-	-	0,46	KRV 52 PP	
	24	20	66	40,5	9	0,8	36,5	M 20×1,5	21	-	4	1	10	-	0,46	KRV 52 PPA	
	24	20	66	40,5	9	0,8	31	M 20×1,5	21	-	4	1	10	-	0,45	NUKR 52 A	
	24	20	66	40,5	9	0,8	31	M 20×1,5	21	-	4	1	10	-	0,45	PWKR 52.2RS	
	24	24	66	40,5	-	0,8	37	M 20×1,5	21	8	-	1	-	1	18	0,48	KRE 52 PP
	24	24	66	40,5	-	0,8	36,5	M 20×1,5	21	-	-	1	10	1	18	0,47	KRE 52 PPA
	24	24	66	40,5	-	0,8	31	M 20×1,5	21	-	-	1	10	1	18	0,47	NUKRE 52 A
	24	24	66	40,5	-	0,8	31	M 20×1,5	21	-	-	1	10	1	18	0,47	PWKRE 52.2RS
62	29	24	80	49,5	11	0,8	44	M 24×1,5	25	-	4	1	14	-	0,79	KR 62 PPB	
	29	24	80	49,5	11	0,8	44	M 24×1,5	25	-	4	1	14	-	0,77	KR 62 PPA	
	29	24	80	49,5	11	0,8	44	M 24×1,5	25	-	4	1	14	-	0,80	KRV 62 PPB	
	29	24	80	49,5	11	0,8	44	M 24×1,5	25	-	4	1	14	-	0,79	KRV 62 PPA	
	28	24	80	49,5	11	1,3	38	M 24×1,5	25	-	4	1	14	-	0,80	NUKR 62 A	
	28	24	80	49,5	11	1,3	38	M 24×1,5	25	-	4	1	14	-	0,80	PWKR 62.2RS	
	29	28	80	49,5	-	0,8	44	M 24×1,5	25	-	-	1	14	1	22	0,82	KRE 62 PPB
	29	28	80	49,5	-	0,8	44	M 24×1,5	25	-	-	1	14	1	22	0,80	KRE 62 PPA
	28	28	80	49,5	-	1,3	38	M 24×1,5	25	-	-	1	14	1	22	0,82	NUKRE 62 A
	28	28	80	49,5	-	1,3	38	M 24×1,5	25	-	-	1	14	1	22	0,82	PWKRE 62.2RS

¹⁾ All cam followers of the KR design where the designation is printed in grey are gradually being replaced by more robust designs

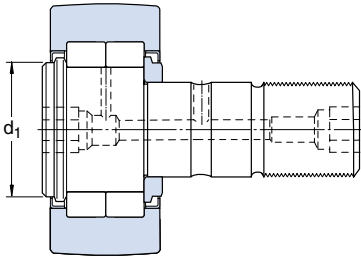

Series NUKR

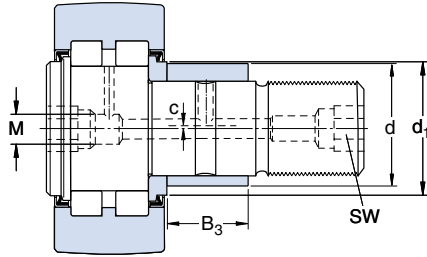

Series PWKRE.2RS

Designation ¹⁾	Basic load ratings		Fatigue load limit P_u	Maximum radial forces		Speed rating
	dynamic C	static C_0		dynamic F_r	static F_{0r}	
–	N		N	N		r/min
KR 47 PP	14 700	24 500	2 900	23 600	33 500	2 400
KR 47 PPA	14 700	24 500	2 900	23 600	33 500	2 400
KRV 47 PP	19 400	41 500	5 000	30 500	43 000	1 400
KRV 47 PPA	19 400	41 500	5 000	30 500	43 000	1 400
NUKR 47 A	28 600	33 500	3 900	17 600	25 000	4 200
PWKR 47.2RS	22 900	24 500	2 800	18 300	26 000	3 800
KRE 47 PP	14 700	24 500	2 900	23 600	33 500	2 400
KRE 47 PPA	14 700	24 500	2 900	23 600	33 500	2 400
NUKRE 47 A	28 600	33 500	3 900	17 600	25 000	4 200
PWKRE 47.2RS	22 900	24 500	2 800	18 300	26 000	3 800
KR 52 PP	15 700	27 000	3 200	36 000	51 000	2 400
KR 52 PPA	15 700	27 000	3 200	36 000	51 000	2 400
KRV 52 PP	20 900	46 500	5 600	45 000	64 000	1 300
KRV 52 PPA	20 900	46 500	5 600	45 000	64 000	1 300
NUKR 52 A	29 700	36 000	4 250	18 000	25 500	4 200
PWKR 52.2RS	23 800	26 500	3 050	18 600	26 500	2 800
KRE 52 PP	15 700	27 000	3 200	36 000	51 000	2 400
KRE 52 PPA	15 700	27 000	3 200	36 000	51 000	2 400
NUKRE 52 A	29 700	36 000	4 250	18 000	25 500	4 200
PWKRE 52.2RS	23 800	26 500	3 050	18 600	26 500	2 800
KR 62 PPB	24 600	44 000	5 500	58 500	85 000	1 900
KR 62 PPA	24 600	44 000	5 500	58 500	85 000	1 900
KRV 62 PPB	31 400	72 000	9 000	72 000	102 000	1 100
KRV 62 PPA	31 400	72 000	9 000	72 000	102 000	1 100
NUKR 62 A	41 300	48 000	5 850	25 000	36 000	2 600
PWKR 62.2RS	31 900	32 500	4 050	20 400	29 000	2 200
KRE 62 PPB	24 600	44 000	5 500	58 500	85 000	1 900
KRE 62 PPA	24 600	44 000	5 500	58 500	85 000	1 900
NUKRE 62 A	41 300	48 000	5 850	25 000	36 000	2 600
PWKRE 62.2RS	31 900	32 500	4 050	20 400	29 000	2 200

¹⁾ All cam followers of the KR design where the designation is printed in grey are gradually being replaced by more robust designs



Cam followers D 72 – 90 mm

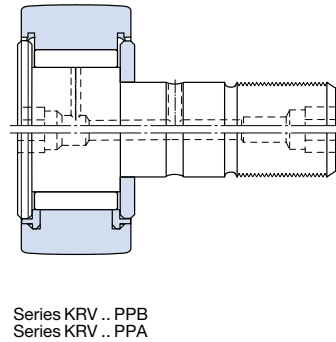
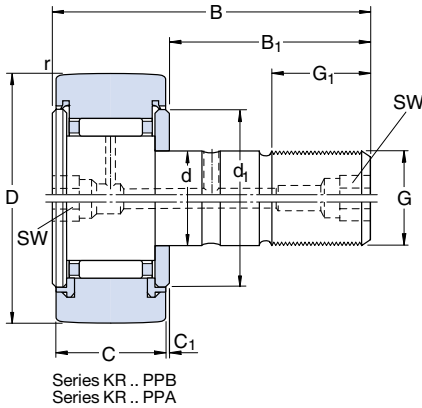

Dimensions Cam follower

D	C	d	B	B ₁	B ₂	C ₁	d ₁	G	G ₁	M ₁	r _{min}	SW	Eccentric collar c	B ₃	Mass kg	Designation ¹⁾	
mm																	
kg																	
-																	
72	29	24	80	49,5	11	0,8	44	M 24×1,5	25	4	1,1	14	-	-	1,01	KR 72 PPB	
	29	24	80	49,5	11	0,8	44	M 24×1,5	25	4	1,1	14	-	-	1,05	KR 72 PPA	
	29	24	80	49,5	11	0,8	44	M 24×1,5	25	4	1,1	14	-	-	1,05	KRV 72 PPB	
	29	24	80	49,5	11	0,8	44	M 24×1,5	25	4	1,1	14	-	-	1,03	KRV 72 PPA	
	28	24	80	49,5	11	1,3	44	M 24×1,5	25	4	1,1	14	-	-	1,02	NUKR 72 A	
	28	24	80	49,5	11	1,3	44	M 24×1,5	25	4	1,1	14	-	-	1,02	PWKR 72.2RS	
	29	28	80	49,5	-	0,8	44	M 24×1,5	25	-	1,1	14	1	22	1,04	KRE 72 PPB	
	29	28	80	49,5	-	0,8	44	M 24×1,5	25	-	1,1	14	1	22	1,04	KRE 72 PPA	
	28	28	80	49,5	-	1,3	44	M 24×1,5	25	-	1,1	14	1	22	1,05	NUKRE 72 A	
	28	28	80	49,5	-	1,3	44	M 24×1,5	25	-	1,1	14	1	22	1,05	PWKRE 72.2RS	
	80	35	30	100	63	15	1	53	M 30×1,5	32	4	1,1	14	-	-	1,55	KR 80 PPB
		35	30	100	63	15	1	53	M 30×1,5	32	4	1,1	14	-	-	1,61	KR 80 PPA
35		30	100	63	15	1	53	M 30×1,5	32	4	1,1	14	-	-	1,55	KRV 80 PPB	
35		30	100	63	15	1	53	M 30×1,5	32	4	1,1	14	-	-	1,64	KRV 80 PPA	
35		30	100	63	15	1	47	M 30×1,5	32	4	1,1	14	-	-	1,60	NUKR 80 A	
35		30	100	63	15	1	47	M 30×1,5	32	4	1,1	14	-	-	1,60	PWKR 80.2RS	
35		35	100	63	-	1	53	M 30×1,5	32	-	1,1	14	1,5	29	1,67	KRE 80 PPB	
35		35	100	63	-	1	53	M 30×1,5	32	-	1,1	14	1,5	29	1,67	KRE 80 PPA	
35		35	100	63	-	1	47	M 30×1,5	32	-	1,1	14	1,5	29	1,67	NUKRE 80 A	
35		35	100	63	-	1	47	M 30×1,5	32	-	1,1	14	1,5	29	1,67	PWKRE 80.2RS	
90		35	30	100	63	15	1	53	M 30×1,5	32	4	1,1	14	-	-	1,95	KR 90 PPB
		35	30	100	63	15	1	53	M 30×1,5	32	4	1,1	14	-	-	1,98	KR 90 PPA
	35	30	100	63	15	1	53	M 30×1,5	32	4	1,1	14	-	-	1,95	KRV 90 PPB	
	35	30	100	63	15	1	53	M 30×1,5	32	4	1,1	14	-	-	2,00	KRV 90 PPA	
	35	30	100	63	15	1	47	M 30×1,5	32	4	1,1	14	-	-	1,96	NUKR 90 A	
	35	30	100	63	15	1	47	M 30×1,5	32	4	1,1	14	-	-	1,96	PWKR 90.2RS	
	35	35	100	63	-	1	53	M 30×1,5	32	-	1,1	14	1,5	29	2,03	KRE 90 PPB	
	35	35	100	63	-	1	53	M 30×1,5	32	-	1,1	14	1,5	29	2,03	KRE 90 PPA	
	35	35	100	63	-	1	47	M 30×1,5	32	-	1,1	14	1,5	29	2,02	NUKRE 90 A	
	35	35	100	63	-	1	47	M 30×1,5	32	-	1,5	14	1,5	29	2,02	PWKRE 90.2RS	

¹⁾ All cam followers of the KR design where the designation is printed in grey are gradually being replaced by more robust designs

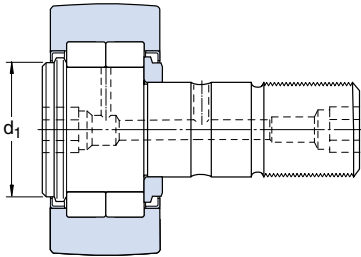

Series NUKR

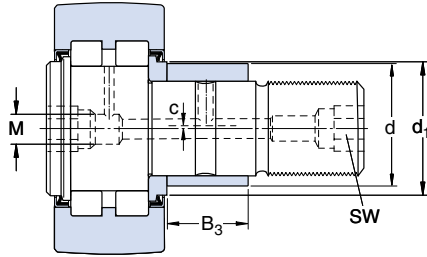

Series PWKRE.2RS

Designation ¹⁾	Basic load ratings		Fatigue load limit P_u	Maximum radial forces		Speed rating
	dynamic C	static C_0		dynamic F_r	static F_{0r}	
–	N		N	N		r/min
KR 72 PPB	26 000	48 000	6 000	100 000	143 000	1 900
KR 72 PPA	26 000	48 000	6 000	100 000	143 000	1 900
KRV 72 PPB	33 000	80 000	9 800	118 000	170 000	1 100
KRV 72 PPA	33 000	80 000	9 800	118 000	170 000	1 100
NUKR 72 A	45 700	58 500	7 100	34 500	50 000	2 600
PWKR 72.2RS	39 600	45 000	5 600	47 500	68 000	2 200
KRE 72 PPB	26 000	48 000	6 000	100 000	143 000	1 900
KRE 72 PPA	26 000	48 000	6 000	100 000	143 000	1 900
NUKRE 72 A	45 700	58 500	7 100	34 500	50 000	2 600
PWKRE 72.2RS	39 600	45 000	5 600	47 500	68 000	2 200
KR 80 PPB	36 900	72 000	9 000	106 000	150 000	1 300
KR 80 PPA	36 900	72 000	9 000	106 000	150 000	1 300
KRV 80 PPB	45 700	114 000	14 000	122 000	176 000	850
KRV 80 PPA	45 700	114 000	14 000	122 000	176 000	850
NUKR 80 A	69 300	86 500	10 800	48 000	69 500	1 800
PWKR 80.2RS	57 200	73 500	9 300	64 000	91 500	1 800
KRE 80 PPB	36 900	72 000	9 000	106 000	150 000	1 300
KRE 80 PPA	36 900	72 000	9 000	106 000	150 000	1 300
NUKRE 80 A	69 300	86 500	10 800	48 000	69 500	1 800
PWKRE 80.2RS	57 200	73 500	9 300	64 000	91 500	1 800
KR 90 PPB	38 000	76 500	9 500	160 000	228 000	1 300
KR 90 PPA	38 000	76 500	9 500	160 000	228 000	1 300
KRV 90 PPB	47 300	122 000	15 000	183 000	260 000	850
KRV 90 PPA	47 300	122 000	15 000	183 000	260 000	850
NUKR 90 A	78 100	102 000	12 700	86 500	125 000	1 800
PWKR 90.2RS	62 700	85 000	10 800	108 000	153 000	1 800
KRE 90 PPB	38 000	76 500	9 500	160 000	228 000	1 300
KRE 90 PPA	38 000	76 500	9 500	160 000	228 000	1 300
NUKRE 90 A	78 100	102 000	12 700	86 500	125 000	1 800
PWKRE 90.2RS	62 700	85 000	10 800	108 000	153 000	1 800

¹⁾ All cam followers of the KR design where the designation is printed in grey are gradually being replaced by more robust designs





Components and accessories

Inner rings	page 204
Needle rollers	page 211
Seals	page 214

Inner rings

Product tables page 207

SKF also supplies loose inner rings for needle roller bearings. Their use is particularly advantageous where needle roller and cage assemblies and drawn cup needle roller bearings are used, but where the shaft cannot be hardened and ground, i.e. raceways cannot be machined in the shaft. It has often been found beneficial to combine needle roller bearings with extended inner rings in order to permit larger axial displacements of the shaft relative to the housing than is possible with the standard-width rings, or to provide an ideal counterface for the lips of rubbing seals.

Three designs of needle roller bearing inner rings can be supplied by SKF:

- inner rings, series IR
- inner rings, series IRZ
- inner rings, series LR

Inner rings, series IR

Inner rings of series IR (→ fig 1) are the standard SKF inner rings for needle roller bearings. They are made of carbon chromium steel and are hardened and ground. To facilitate their combination with needle roller and cage assemblies or the outer ring assembly of needle roller bearings, they have a lead-in at each side of the raceway.

Some sizes of IR inner rings have a lubrication hole (→ fig 2). Such inner rings are identified by the designation suffix IS1.

Tolerances

The bore diameter and width of the IR inner rings are made to Normal tolerances in accordance with ISO 492:1994 (→ Table 2, page 17). The raceway diameter F tolerances have been chosen to give a normal radial internal clearance if the recommended shaft and housing tolerances are applied.

Fig 1

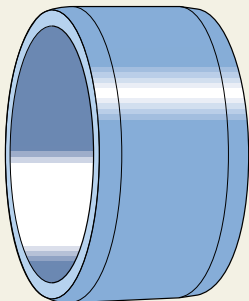
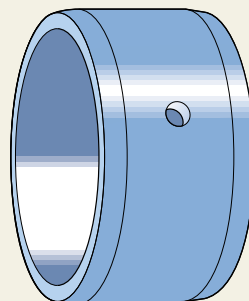

Fig 2



Inner ring seatings

The seatings for needle roller bearings on the shaft should be according to the following recommendations.

Shaft diameter tolerances

When inner rings are used under conditions of point load they may be mounted with a loose fit. In such cases the seatings should be machined to tolerance h6 or g6.

When the load rotates, the inner rings should have an interference fit. Sufficient interference will be obtained if the shaft tolerances given in **Table 1** are used.

Cylindricity

The cylindricity to ISO 1101-1985 should be as follows:

- inner rings under point load IT5/2
- inner rings under rotating load IT4/2

Runout

The abutments for the inner rings on the shaft should have a runout corresponding to IT4.

Inner rings, series IRZ

The inner rings of series IRZ (→ **fig 3**) are made of carbon chromium steel, and are hardened and ground. The raceway of these inner rings covers the whole ring width. For this reason, the use of IRZ inner rings is preferred where axial space is limited at the same time as relatively large axial displacements of the shaft have to be accommodated, or where counterfaces are required for seals.

All inner rings of series IRZ have one lubrication hole and carry the designation suffix IS1 to indicate this.

Tolerances

The bore diameter and width tolerances for IRZ inner rings are in accordance with the Normal tolerances specified in ISO 492:1994 (→ **Table 2**, **page 17**). The tolerances for the raceway diameter F have been chosen to give a normal radial internal clearance in the bearing, if the recommended shaft and housing seating tolerances are applied (→ "Inner ring seatings").

Table 1

Recommended shaft diameter tolerances		
Shaft diameter		ISO tolerance
over	incl.	
mm		–
–	50	k6
50	120	m6
120	250	n6

Fig 3

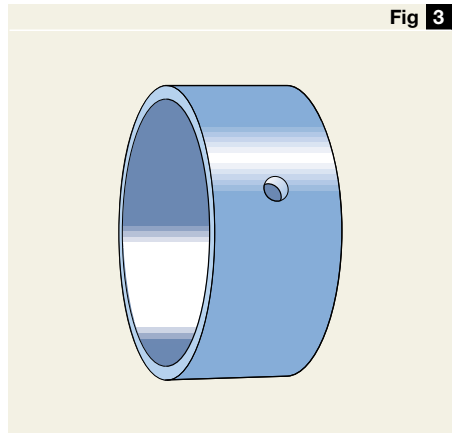

Inner rings

Inner rings, series LR

LR inner rings (→ **fig 4**) are made of carbon chromium steel and hardened. The bore and outside diameters are ground. The side faces are not ground and the edges are only smoothed. For applications where the larger width and runout tolerances are unimportant, LR inner rings offer an economic solution. They are, therefore, often used in combination with drawn cup needle roller bearings or needle roller and cage assemblies.

Tolerances

The bore diameter of LR inner rings is made to tolerance K6, the raceway diameter to h6 and the width to h12.

The values for the deviation from the nominal dimension for the tolerances mentioned above are given in **Table 2**.

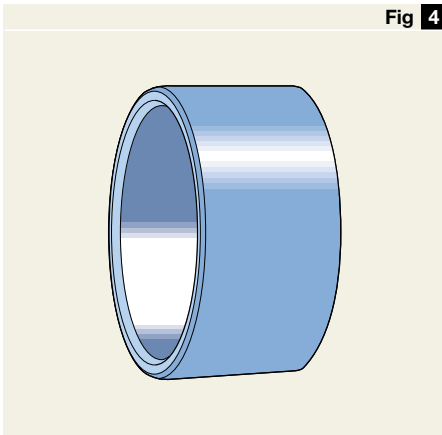
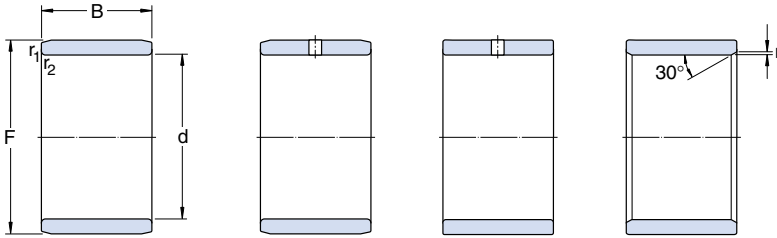

Fig 4

Table 2

ISO tolerances		h6		h12		K6	
Nominal dimension	over incl.	Deviations		Deviations		Deviations	
		high	low	high	low	high	low
mm		µm		µm		µm	
6	10	0	-9	0	-150	+2	-7
10	18	0	-11	0	-180	+2	-9
18	30	0	-13	0	-210	+2	-11
30	50	0	-16	0	-250	+3	-13
50	80	0	-19	0	-300	+4	-15

Inner rings
d 5–17 mm



Series IR

Series IR .. IS1

Series IRZ .. IS1

Series LR

Dimensions				Mass	Designation
d	F	B	$r_1, r_{1,2}$ min		
mm				kg	-
5	8	12	0,3	0,0028	IR 5×8×12
	8	16	0,3	0,0038	IR 5×8×16
6	9	12	0,3	0,0032	IR 6×9×12
	9	16	0,3	0,0043	IR 6×9×16
	10	10	0,3	0,0037	IR 6×10×10 IS1
	10	12	0,3	0,0046	IRZ 6×10×12 IS1
7	10	10,5	0,3	0,0031	IR 7×10×10,5
	10	10,5	0,3	0,0031	LR 7×10×10,5
	10	12	0,3	0,0036	IR 7×10×12
	10	16	0,3	0,0049	IR 7×10×16
8	12	10	0,3	0,0048	IR 8×12×10 IS1
	12	10,5	0,3	0,0050	IR 8×12×10,5
	12	10,5	0,3	0,0050	LR 8×12×10,5
	12	12	0,3	0,0057	IRZ 8×12×12 IS1
	12	12,5	0,3	0,0059	IR 8×12×12,5
	12	12,5	0,3	0,0059	LR 8×12×12,5
9	12	12	0,3	0,0045	IR 9×12×12
	12	16	0,3	0,0061	IR 9×12×16
10	13	12,5	0,3	0,0052	IR 10×13×12,5
	13	12,5	0,3	0,0052	LR 10×13×12,5
	14	12	0,3	0,0073	IR 10×14×12 IS1
	14	13	0,3	0,0074	IR 10×14×13
	14	14	0,3	0,0080	IRZ 10×14×14 IS1
	14	16	0,3	0,0092	IR 10×14×16
	14	20	0,3	0,012	IR 10×14×20
12	15	12	0,3	0,0058	IR 12×15×12
	15	12,5	0,3	0,0061	IR 12×15×12,5
	15	12,5	0,3	0,0061	LR 12×15×12,5
	15	16	0,3	0,0080	IR 12×15×16
	15	16,5	0,3	0,0081	IR 12×15×16,5
	15	16,5	0,3	0,0081	LR 12×15×16,5
	15	22,5	0,3	0,011	IR 12×15×22,5
	15	22,5	0,3	0,011	LR 12×15×22,5

Dimensions				Mass	Designation
d	F	B	$r_1, r_{1,2}$ min		
mm				kg	-
12	16	12	0,3	0,0079	IR 12×16×12 IS1
	16	13	0,3	0,0087	IR 12×16×13
	16	14	0,3	0,0095	IRZ 12×16×14 IS1
	16	16	0,3	0,011	IR 12×16×16
	16	20	0,3	0,014	IR 12×16×20
16	22	0,3	0,015	IR 12×16×22	
14	17	17	0,3	0,010	IR 14×17×17
15	18	12,5	0,3	0,0072	LR 15×18×12,5
	18	16	0,3	0,0096	IR 15×18×16
	18	16,5	0,3	0,0099	IR 15×18×16,5
	18	16,5	0,3	0,0099	LR 15×18×16,5
	19	16	0,3	0,013	IR 15×19×16
	19	20	0,3	0,016	IR 15×19×20
	20	12	0,3	0,012	IR 15×20×12 IS1
	20	13	0,3	0,014	IR 15×20×13
17	20	14	0,3	0,015	IRZ 15×20×14 IS1
	20	23	0,3	0,024	IR 15×20×23
	20	16	0,3	0,011	IR 17×20×16
	20	16,5	0,3	0,011	IR 17×20×16,5
	20	16,5	0,3	0,011	LR 17×20×16,5
	20	20	0,3	0,014	IR 17×20×20
	20	20,5	0,3	0,014	IR 17×20×20,5
	20	20,5	0,3	0,014	LR 17×20×20,5
	20	30,5	0,3	0,021	IR 17×20×30,5
	20	30,5	0,3	0,021	LR 17×20×30,5
	21	16	0,3	0,014	IR 17×21×16
	21	20	0,3	0,018	IR 17×21×20
	22	13	0,3	0,015	IR 17×22×13
22	14	0,3	0,016	IRZ 17×22×14 IS1	
22	16	0,3	0,019	IR 17×22×16	
22	23	0,3	0,027	IR 17×22×23	
24	20	0,3	0,034	IR 17×24×20	

Inner rings
d 20 – 85 mm

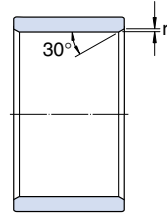
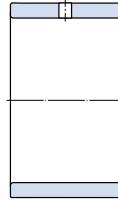
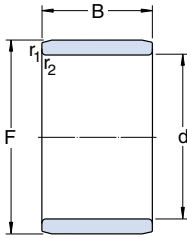

Series IR

Series IR .. IS1

Series IRZ .. IS1

Series LR

Dimensions		Mass		Designation	
d	F	B	r, r _{1,2} min		
mm			kg	-	
20	24	16	0,3	0,017	IR 20×24×16
	24	20	0,3	0,021	IR 20×24×20
	25	12,5	0,3	0,016	LR 20×25×12.5
	25	16	0,3	0,021	IR 20×25×16 IS1
	25	16,5	0,3	0,022	LR 20×25×16.5
	25	17	0,3	0,022	IR 20×25×17
	25	18	0,3	0,024	IRZ 20×25×18 IS1
	25	20	0,3	0,028	IR 20×25×20
	25	20,5	0,3	0,028	IR 20×25×20.5
	25	20,5	0,3	0,028	LR 20×25×20.5
	25	26,5	0,3	0,036	IR 20×25×26.5
	25	26,5	0,3	0,036	LR 20×25×26.5
	25	30	0,3	0,041	IR 20×25×30
	25	38,5	0,3	0,053	IR 20×25×38.5
25	38,5	0,3	0,053	LR 20×25×38.5	
28	20	0,6	0,045	IR 20×28×20	
22	26	16	0,3	0,018	IR 22×26×16
	26	20	0,3	0,023	IR 22×26×20
	28	17	0,3	0,030	IR 22×28×17
	28	20	0,3	0,035	IR 22×28×20
	28	20,5	0,3	0,036	IR 22×28×20.5
	28	20,5	0,3	0,036	LR 22×28×20.5
	28	30	0,3	0,054	IR 22×28×30
25	29	20	0,3	0,026	IR 25×29×20
	29	30	0,3	0,039	IR 25×29×30
	30	12,5	0,3	0,020	LR 25×30×12.5
	30	16	0,3	0,026	IR 25×30×16 IS1
	30	16,5	0,3	0,027	LR 25×30×16.5
	30	17	0,3	0,028	IR 25×30×17
	30	18	0,3	0,030	IRZ 25×30×18 IS1
	30	20	0,3	0,033	IR 25×30×20
	30	20,5	0,3	0,034	IR 25×30×20.5
	30	20,5	0,3	0,034	LR 25×30×20.5
	30	26,5	0,3	0,043	IR 25×30×26.5
	30	26,5	0,3	0,043	LR 25×30×26.5
	30	30	0,3	0,050	IR 25×30×30
	30	32	0,3	0,053	IR 25×30×32
	30	38,5	0,3	0,064	IR 25×30×38.5
	30	38,5	0,3	0,064	LR 25×30×38.5
32	22	0,6	0,052	IR 25×32×22	

Dimensions		Mass		Designation	
d	F	B	r, r _{1,2} min		
mm			kg	-	
28	32	17	0,3	0,025	IR 28×32×17
	32	20	0,3	0,028	IR 28×32×20
	32	30	0,3	0,044	IR 28×32×30
30	35	12,5	0,3	0,023	LR 30×35×12.5
	35	13	0,3	0,025	IR 30×35×13
	35	16	0,3	0,031	IR 30×35×16
	35	16,5	0,3	0,031	LR 30×35×16.5
	35	17	0,3	0,032	IR 30×35×17
	35	18	0,3	0,035	IRZ 30×35×18 IS1
	35	20	0,3	0,040	IR 30×35×20
	35	20,5	0,3	0,041	IR 30×35×20.5
	35	20,5	0,3	0,041	LR 30×35×20.5
	35	26	0,3	0,050	IR 30×35×26
35	30	0,3	0,059	IR 30×35×30	
37	18	0,6	0,050	IR 30×37×18	
37	22	0,6	0,061	IR 30×37×22	
38	20	0,6	0,065	IR 30×38×20 IS1	
32	37	20	0,3	0,042	IR 32×37×20
	37	30	0,3	0,063	IR 32×37×30
	40	20	0,6	0,068	IR 32×40×20
	40	36	0,6	0,12	IR 32×40×36
33	37	13	0,3	0,022	IR 33×37×13
35	40	12,5	0,3	0,027	LR 35×40×12.5
	40	16,5	0,3	0,037	LR 35×40×16.5
	40	17	0,3	0,038	IR 35×40×17
	40	20	0,3	0,044	IR 35×40×20
	40	20,5	0,3	0,046	IR 35×40×20.5
	40	20,5	0,3	0,046	LR 35×40×20.5
	40	30	0,3	0,068	IR 35×40×30
	42	20	0,6	0,064	IR 35×42×20 IS1
	42	21	0,6	0,068	IRZ 35×42×21 IS1
	42	23	0,6	0,074	IRZ 35×42×23 IS1
	42	36	0,6	0,12	IR 35×42×36
43	22	0,6	0,082	IR 35×43×22	

Dimensions				Mass	Designation
d	F	B	r, r _{1,2} min	kg	-
mm				kg	-
38	43	20	0,3	0,048	IR 38×43×20
	43	30	0,3	0,074	IR 38×43×30
40	45	16,5	0,3	0,041	LR 40×45×16.5
	45	17	0,3	0,043	IR 40×45×17
	45	20	0,3	0,051	IR 40×45×20
	45	20,5	0,3	0,053	IR 40×45×20.5
	45	20,5	0,3	0,053	LR 40×45×20.5
	45	30	0,3	0,077	IR 40×45×30
	48	22	0,6	0,092	IR 40×48×22
	48	23	0,6	0,097	IRZ 40×48×23 IS1
	48	40	0,6	0,17	IR 40×48×40
	50	20	1	0,11	IR 40×50×20 IS1
	50	22	1	0,12	IR 40×50×22
42	47	20	0,3	0,054	IR 42×47×20
	47	30	0,3	0,081	IR 42×47×30
45	50	20,5	0,3	0,058	LR 45×50×20.5
	50	25	0,6	0,071	IR 45×50×25
	50	25,5	0,3	0,074	IR 45×50×25.5
	50	25,5	0,3	0,074	LR 45×50×25.5
	50	35	0,6	0,10	IR 45×50×35
	52	22	0,6	0,089	IR 45×52×22
	52	23	0,6	0,093	IRZ 45×52×23 IS1
	52	40	0,6	0,16	IR 45×52×40
	55	20	1	0,12	IR 45×55×20 IS1
	55	22	1	0,13	IR 45×55×22
50	55	20	0,6	0,063	IR 50×55×20 IS1
	55	20,5	0,6	0,064	LR 50×55×20.5
	55	25	0,6	0,078	IR 50×55×25
	55	35	0,6	0,11	IR 50×55×35
	58	22	0,6	0,12	IR 50×58×22
	58	23	0,6	0,12	IRZ 50×58×23 IS1
	58	40	0,6	0,21	IR 50×58×40
	60	20	1	0,13	IR 50×60×20 IS1
	60	25	1	0,16	IR 50×60×25
	60	28	1	0,18	IR 50×60×28

Dimensions				Mass	Designation
d	F	B	r, r _{1,2} min	kg	-
mm				kg	-
55	60	25	0,6	0,086	IR 55×60×25
	60	35	0,6	0,12	IR 55×60×35
	63	25	1	0,14	IR 55×63×25
	63	45	1	0,26	IR 55×63×45
	65	28	1,1	0,20	IR 55×65×28
60	68	25	1	0,15	IR 60×68×25
	68	35	0,6	0,21	IR 60×68×35
	68	45	1	0,28	IR 60×68×45
	70	25	1	0,20	IR 60×70×25
	70	28	1,1	0,22	IR 60×70×28
65	72	25	1	0,14	IR 65×72×25
	72	45	1	0,26	IR 65×72×45
	73	25	1	0,16	IR 65×73×25
	73	35	1	0,23	IR 65×73×35
	75	28	1,1	0,23	IR 65×75×28
70	80	25	1	0,22	IR 70×80×25
	80	30	1	0,27	IR 70×80×30
	80	35	1	0,31	IR 70×80×35
	80	54	1	0,49	IR 70×80×54
75	85	25	1	0,24	IR 75×85×25
	85	30	1	0,29	IR 75×85×30
	85	35	1	0,34	IR 75×85×35
	85	54	1	0,52	IR 75×85×54
80	90	25	1	0,25	IR 80×90×25
	90	30	1	0,30	IR 80×90×30
	90	35	1	0,36	IR 80×90×35
	90	54	1	0,55	IR 80×90×54
85	95	26	1	0,28	IR 85×95×26
	95	36	1	0,39	IR 85×95×36
	100	35	1,1	0,58	IR 85×100×35
	100	63	1,1	1,05	IR 85×100×63

Inner rings
d 90 – 380 mm

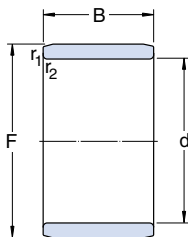

Dimensions				Mass	Designation
d	F	B	r _{1,2} min		
mm				kg	-
90	100	26	1	0,29	IR 90×100×26
	100	30	1	0,34	IR 90×100×30
	100	36	1	0,41	IR 90×100×36
	105	35	1,1	0,61	IR 90×105×35
	105	63	1,1	1,10	IR 90×105×63
95	105	26	1	0,31	IR 95×105×26
	105	36	1	0,43	IR 95×105×36
	110	35	1,1	0,64	IR 95×110×35
	110	63	1,1	1,15	IR 95×110×63
100	110	30	1,1	0,37	IR 100×110×30
	110	40	1,1	0,51	IR 100×110×40
	115	40	1,1	0,78	IR 100×115×40
110	120	30	1	0,41	IR 110×120×30
	125	40	1,1	0,84	IR 110×125×40
120	130	30	1	0,44	IR 120×130×30
	135	45	1,1	1,00	IR 120×135×45
130	145	35	1,1	0,86	IR 130×145×35
	150	50	1,5	1,70	IR 130×150×50
140	155	35	1,1	0,92	IR 140×155×35
	160	50	1,5	1,80	IR 140×160×50
150	165	40	1,1	1,10	IR 150×165×40
160	175	40	1,1	1,20	IR 160×175×40
170	185	45	1,1	1,45	IR 170×185×45
180	195	45	1,1	1,50	IR 180×195×45
190	210	50	1,5	2,40	IR 190×210×50
200	220	50	1,5	2,50	IR 200×220×50
220	240	50	1,5	2,75	IR 220×240×50
240	265	60	2	4,60	IR 240×265×60

Dimensions				Mass	Designation
d	F	B	r _{1,2} min		
mm				kg	-
260	285	60	2	5,00	IR 260×285×60
280	305	69	2	6,10	IR 280×305×69
300	330	80	2,1	9,20	IR 300×330×80
320	350	80	2,1	9,80	IR 320×350×80
340	370	80	2,1	10,0	IR 340×370×80
360	390	80	2,1	11,0	IR 360×390×80
380	415	100	2,1	17,0	IR 380×415×100

Needle rollers

Product tables **page 212**

SKF also supplies loose needle rollers. They can be used to produce full complement bearing arrangements for slow speed or oscillating operation which can carry heavy loads and are economic provided shaft and housing bore can serve as raceways. These should have the same quality and hardness as the rings of needle roller bearings. SKF needle rollers conform to ISO 3096:1996 for rollers with flat ends (B design). They are made from carbon chromium (bearing steel) and have a hardness of 58 to 65 HRC. The cylindrical surface of the rollers is slightly relieved towards the roller ends in order to avoid damaging edge stresses.

SKF supplies grade G2 needle rollers (ISO 6193-1980) with the dimensional and form tolerances shown in **Table 1**. The rollers are gauged according to their deviations from the nominal diameter. Needle rollers of each gauge are packed separately and the package is marked with the smallest and largest diameter deviations, e.g. N/M2

or M2/M4. M signifies minus and N zero. For a 2 mm nominal diameter needle roller with the deviations M2/M4, the actual diameter will lie between 1,996 and 1,998 mm. For bearing arrangements it is recommended to use needle rollers of the same gauge.

A consignment of needle rollers of the same nominal diameter may contain packages of one or more gauges depending on availability at the time.



Table 1

Dimensional and form accuracy of needle rollers of grade G2

Diameter D_w Deviation		Gauge tolerance	Gauge limits	Circularity tolerance to ISO 1101	Length L_w Tolerance
high	low				
μm					-
0	-10	2	0/-2 -1/-3 -2/-4 -3/-5 -4/-6 -5/-7 -6/-8 -7/-9 -8/-10	1	h13

Needle rollers

D_w 1–6 mm

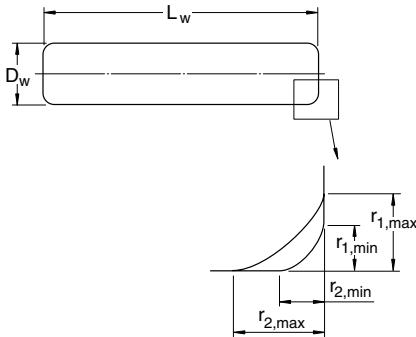

Dimensions					Mass	Designation
D_w	L_w	$r_{1,2}$ min	r_1 max	r_2 max	per 100	
mm					kg	–
1	7,8	0,1	0,4	0,6	0,048	RN-1×7.8 BF
1,5	5,8	0,1	0,4	0,6	0,081	RN-1.5×5.8 BF
	6,8	0,1	0,4	0,6	0,094	RN-1.5×6.8 BF
	7,8	0,1	0,4	0,6	0,108	RN-1.5×7.8 BF
	9,8	0,1	0,4	0,6	0,136	RN-1.5×9.8 BF
	11,8	0,1	0,4	0,6	0,164	RN-1.5×11.8 BF
	13,8	0,1	0,4	0,6	0,191	RN-1.5×13.8 BF
2	6,3	0,2	0,6	0,8	0,16	RN-2×6.3 BF
	7,8	0,2	0,6	0,8	0,19	RN-2×7.8 BF
	9,8	0,2	0,6	0,8	0,24	RN-2×9.8 BF
	11,8	0,2	0,6	0,8	0,29	RN-2×11.8 BF
	13,8	0,2	0,6	0,8	0,34	RN-2×13.8 BF
	15,8	0,2	0,6	0,8	0,39	RN-2×15.8 BF
	17,8	0,2	0,6	0,8	0,44	RN-2×17.8 BF
	19,8	0,2	0,6	0,8	0,49	RN-2×19.8 BF
	21,8	0,2	0,6	0,8	0,54	RN-2×21.8 BF
2,5	7,8	0,2	0,6	0,8	0,30	RN-2.5×7.8 BF
	9,8	0,2	0,6	0,8	0,38	RN-2.5×9.8 BF
	11,8	0,2	0,6	0,8	0,45	RN-2.5×11.8 BF
	13,8	0,2	0,6	0,8	0,53	RN-2.5×13.8 BF
	15,8	0,2	0,6	0,8	0,61	RN-2.5×15.8 BF
	17,8	0,2	0,6	0,8	0,69	RN-2.5×17.8 BF
	19,8	0,2	0,6	0,8	0,76	RN-2.5×19.8 BF
	21,8	0,2	0,6	0,8	0,84	RN-2.5×21.8 BF
23,8	0,2	0,6	0,8	0,92	RN-2.5×23.8 BF	
3	9,8	0,2	0,6	0,8	0,54	RN-3×9.8 BF
	11,8	0,2	0,6	0,8	0,65	RN-3×11.8 BF
	13,8	0,2	0,6	0,8	0,77	RN-3×13.8 BF
	15,8	0,2	0,6	0,8	0,88	RN-3×15.8 BF
	17,8	0,2	0,6	0,8	0,99	RN-3×17.8 BF
	19,8	0,2	0,6	0,8	1,10	RN-3×19.8 BF
	21,8	0,2	0,6	0,8	1,21	RN-3×21.8 BF
	23,8	0,2	0,6	0,8	1,32	RN-3×23.8 BF

Dimensions					Mass per 100	Designation
D _w	L _w	r _{1,2} min	r ₁ max	r ₂ max		
mm					kg	-
3,5	11,8	0,3	0,8	1,0	0,89	RN-3.5×11.8 BF
	13,8	0,3	0,8	1,0	1,04	RN-3.5×13.8 BF
	15,8	0,3	0,8	1,0	1,19	RN-3.5×15.8 BF
	17,8	0,3	0,8	1,0	1,34	RN-3.5×17.8 BF
	19,8	0,3	0,8	1,0	1,50	RN-3.5×19.8 BF
	21,8	0,3	0,8	1,0	1,65	RN-3.5×21.8 BF
	29,8	0,3	0,8	1,0	2,25	RN-3.5×29.8 BF
	34,8	0,3	0,8	1,0	2,63	RN-3.5×34.8 BF
4	11,8	0,3	0,8	1,0	1,16	RN-4×11.8 BF
	13,8	0,3	0,8	1,0	1,36	RN-4×13.8 BF
	15,8	0,3	0,8	1,0	1,56	RN-4×15.8 BF
	17,8	0,3	0,8	1,0	1,76	RN-4×17.8 BF
	19,8	0,3	0,8	1,0	1,95	RN-4×19.8 BF
	21,8	0,3	0,8	1,0	2,15	RN-4×21.8 BF
	23,8	0,3	0,8	1,0	2,35	RN-4×23.8 BF
	25,8	0,3	0,8	1,0	2,55	RN-4×25.8 BF
	27,8	0,3	0,8	1,0	2,74	RN-4×27.8 BF
	29,8	0,3	0,8	1,0	2,94	RN-4×29.8 BF
	34,8	0,3	0,8	1,0	3,43	RN-4×34.8 BF
	39,8	0,3	0,8	1,0	3,93	RN-4×39.8 BF
5	15,8	0,3	0,8	1,0	2,44	RN-5×15.8 BF
	19,8	0,3	0,8	1,0	3,05	RN-5×19.8 BF
	21,8	0,3	0,8	1,0	3,36	RN-5×21.8 BF
	23,8	0,3	0,8	1,0	3,67	RN-5×23.8 BF
	25,8	0,3	0,8	1,0	3,98	RN-5×25.8 BF
	27,8	0,3	0,8	1,0	4,28	RN-5×27.8 BF
	29,8	0,3	0,8	1,0	4,59	RN-5×29.8 BF
	34,8	0,3	0,8	1,0	5,36	RN-5×34.8 BF
	39,8	0,3	0,8	1,0	6,13	RN-5×39.8 BF
6	17,8	0,3	0,8	1,0	3,95	RN-6×17.8 BF

Seals

Product tables page 216

It is not always easy to find commercially available radial shaft seals for bearing arrangements incorporating needle roller bearings because of the very low cross section of these bearings. SKF supplies a range of special low cross section radial shaft seals for such bearing arrangements; the sealing lip is not spring loaded.

Two designs are available: the G design and the SD design. The latter has a secondary dust lip in addition to the primary sealing lip, and is used to retain lubricant in the bearing arrangement while excluding dust and other contaminants.

Radial shaft seals of G design

The G-design radial shaft seals are made of nitrile rubber (NBR) and are reinforced with sheet steel. Except for the smallest seals for shaft diameters up to and including 7 mm (→ fig 1) the steel reinforcement is completely embedded in the rubber (→ fig 2).

The rubber outside diameter provides reliable sealing between the seal and the housing bore.

If the seal is to be used primarily for lubricant retention it should be mounted with the lip pointing inwards; if the primary purpose is to exclude contaminants, the lip should point outwards, away from the bearing.

Radial shaft seals of SD design

The SD-design radial shaft seals (→ fig 3) have a primary sealing lip without garter spring and an additional rubbing lip. The seals are made of polyurethane elastomer reinforced with a ring of polyamide.

The primary sealing lip, i.e. the larger of the two lips, should always point towards the medium which is to be sealed. Thus if protection is required against contaminants, the lip should face outwards; the secondary (smaller) lip will retain lubricant in the bearing arrangement. The space between the

Fig 1

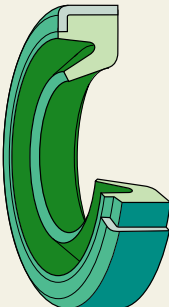
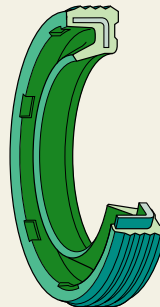

Fig 2



two lips should be filled with grease which will provide additional protection.

The SD seals are resistant to lubricating oils, even those containing small quantities of EP additives, and also to mineral oil based greases.

Design of associated components

The housing bore tolerances normally recommended for needle roller bearings, for example, will give a sufficient interference fit to the seals, and no additional axial location will be needed. To simplify mounting, the bore should have a 5 to 10° lead-in (DIN 3760:1966). The riding surface of the sealing lips on the shaft should be hardened and ground. The surface roughness R_a should lie between 0,2 and 0,8 μm (R_z between 1 and 4 μm) if the maximum permissible peripheral speeds are to be used.

The shaft ends should also have a lead-in to DIN 3760:1966, to prevent dishing of the sealing lips during mounting.

Speeds

The permissible rotational speeds depend on the diameter of the counterface and the permissible maximum circumferential speeds. These are

- 10 m/s for G seals, and
- 7 m/s for SD seals,

provided that the recommendations given under “Design of associated components” are adhered to.

Operating temperature range

The permissible operating temperature range for G-design seals is -40 to $+120$ °C, and for SD-design seals it is -20 to $+100$ °C.

Mounting

The seals should be mounted so that they are concentric with the shaft and perpendicular to it. The use of a suitable mounting tool (\rightarrow fig 4) should be used to prevent the seal from skewing. The outside diameter of G-design seals should be lightly oiled to ease installation. If the shaft ends are not chamfered or rounded, a mounting sleeve (\rightarrow fig 4) should be used to prevent damage to the seal.

Fig 3

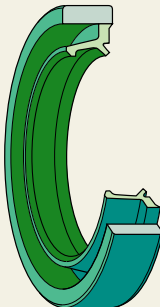
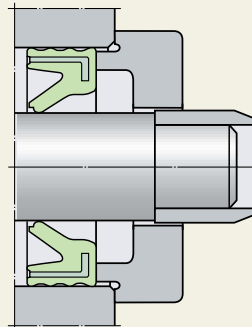
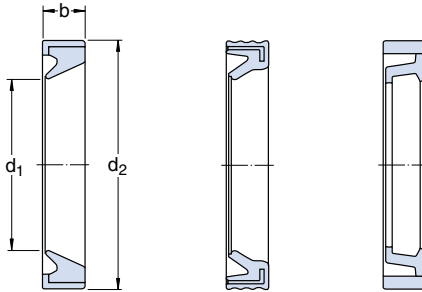

Fig 4



Radial shaft seals with low cross sectional height
d 4–70 mm



Series G
 $d_1 \leq 7 \text{ mm}$

Series G
 $d_1 \geq 8 \text{ mm}$

Series SD

Dimensions			Mass per 100	Designation	Dimensions			Mass per 100	Designation
d_1	d_2	b			d_1	d_2	b		
mm			kg	–	mm			kg	–
4	8	2	0,018	G 4×8×2	16	22	3	0,13	G 16×22×3
						22	3	0,060	SD 16×22×3
5	9	2	0,019	G 5×9×2	16	24	3	0,13	G 16×24×3
		2	0,022	G 5×10×2		24	3	0,080	SD 16×24×3
6	10	2	0,021	G 6×10×2	16	25	3	0,16	G 16×25×3
		2	0,038	G 6×12×2		17	23	3	0,13
7	11	2	0,025	G 7×11×2	23		3	0,060	SD 17×23×3
		2	0,052	G 7×14×2	25		3	0,15	G 17×25×3
8	12	3	0,041	G 8×12×3	25	3	0,080	SD 17×25×3	
		3	0,065	G 8×15×3	18	24	3	0,12	G 18×24×3
		3	0,040	SD 8×15×3		24	3	0,060	SD 18×24×3
9	13	3	0,044	G 9×13×3	26	4	0,18	G 18×26×4	
		3	0,069	G 9×16×3	26	4	0,11	SD 18×26×4	
10	14	3	0,050	G 10×14×3	19	27	4	0,20	G 19×27×4
		3	0,090	G 10×17×3		27	4	0,11	SD 19×27×4
		3	0,044	SD 10×17×3	20	26	4	0,18	G 20×26×4
12	16	3	0,060	G 12×16×3		26	4	0,080	SD 20×26×4
		3	0,090	G 12×18×3	28	4	0,21	G 20×28×4	
		3	0,050	SD 12×18×3	28	4	0,11	SD 20×28×4	
		3	0,10	G 12×19×3	21	29	4	0,22	G 21×29×4
3	0,060	SD 12×19×3	22	28		4	0,18	G 22×28×4	
13	19	3		0,090	G 13×19×3	28	4	0,090	SD 22×28×4
		14		20	3	0,10	G 14×20×3	30	4
3	0,050		SD 14×20×3		30	4	0,13	SD 22×30×4	
3	0,11		G 14×21×3		24	32	4	0,25	G 24×32×4
3	0,13		G 14×22×3			32	4	0,14	SD 24×32×4
3	0,070		SD 14×22×3		25	32	4	0,23	G 25×32×4
15	21	3	0,10	G 15×21×3		33	4	0,25	G 25×33×4
		3	0,050	SD 15×21×3		33	4	0,13	SD 25×33×4
3	0,13	G 15×23×3	35	4		0,26	G 25×35×4		
3	0,070	SD 15×23×3	35	4		0,19	SD 25×35×4		

Dimensions			Mass per 100	Designation
d ₁	d ₂	b		
mm			kg	-
26	34	4	0,26	G 26×34×4
	34	4	0,14	SD 26×34×4
28	35	4	0,24	G 28×35×4
	35	4	0,13	SD 28×35×4
	37	4	0,31	G 28×37×4
29	38	4	0,32	G 29×38×4
30	37	4	0,27	G 30×37×4
	37	4	0,13	SD 30×37×4
	40	4	0,36	G 30×40×4
	40	4	0,21	SD 30×40×4
32	42	4	0,37	G 32×42×4
	42	4	0,24	SD 32×42×4
	45	4	0,51	G 32×45×4
35	42	4	0,30	G 35×42×4
	42	4	0,15	SD 35×42×4
	45	4	0,41	G 35×45×4
	45	4	0,25	SD 35×45×4
37	47	4	0,40	G 37×47×4
	47	4	0,27	SD 37×47×4
38	48	4	0,44	G 38×48×4
	48	4	0,28	SD 38×48×4
40	47	4	0,33	G 40×47×4
	47	4	0,17	SD 40×47×4
	50	4	0,46	G 40×50×4
	50	4	0,29	SD 40×50×4
	52	5	0,48	G 40×52×5
	52	5	0,45	SD 40×52×5
42	52	4	0,47	G 42×52×4
	52	4	0,30	SD 42×52×4
43	53	4	0,48	G 43×53×4

Dimensions			Mass per 100	Designation
d ₁	d ₂	b		
mm			kg	-
45	52	4	0,38	G 45×52×4
	52	4	0,19	SD 45×52×4
	55	4	0,52	G 45×55×4
	55	4	0,32	SD 45×55×4
50	58	4	0,45	G 50×58×4
	58	4	0,24	SD 50×58×4
	62	5	1,05	G 50×62×5
	62	5	0,55	SD 50×62×5
55	63	5	0,71	G 55×63×5
70	78	5	0,90	G 70×78×5



Product index

The product range shown in this catalogue comprises more than 1 600 bearings, support rollers and cam followers, inner rings and accessories. In order to enable the user to quickly find the technical data for a product known only by its designation, the products are listed by designation in alpha-numerical order in this index. The page on which the product will be found is given as well as a code number to identify the product type. The codes are explained in the following.

- 1 Needle roller and cage assembly
- 2 Drawn cup needle roller bearing, with open ends
- 3 Drawn cup needle roller bearing, with closed end
- 4 Needle roller bearing with flanges, without inner ring
- 5 Needle roller bearing with flanges, with inner ring
- 6 Needle roller bearing without flanges, without inner ring
- 7 Needle roller bearing without flanges, with inner ring
- 8 Alignment needle roller bearing, without inner ring
- 9 Alignment needle roller bearing, with inner ring
- 10 Needle roller and cage thrust assembly
- 11 Raceway washer for thrust bearing
- 12 Thrust washer for thrust bearing
- 13 Shaft washer for thrust bearing
- 14 Housing washer for thrust bearing
- 15 Combined needle roller/angular contact ball bearing
- 16 Combined needle roller/thrust ball bearing
- 17 Combined needle roller/cylindrical roller thrust bearing
- 18 Support roller
- 19 Cam follower
- 20 Inner ring
- 21 Needle roller
- 22 Seal

Product index

Designation	Code	Page	Designation	Code	Page
AS 0414	12	125	BK 1412	3	58
AS 0515	12	125	BK 1414 RS	3	58
AS 0619	12	125	BK 1512	3	58
AS 0821	12	125	BK 1516	3	58
AS 1024	12	125	BK 1612	3	58
AS 1226	12	125	BK 1614 RS	3	58
AS 1528	12	125	BK 1616	3	58
AS 1730	12	125	BK 1622	3	58
AS 2035	12	125	BK 1812	3	60
AS 2542	12	125	BK 1816	3	60
AS 3047	12	125	BK 2016	3	60
AS 3552	12	125	BK 2018 RS	3	60
AS 4060	12	125	BK 2020	3	60
AS 4565	12	125	BK 2212	3	60
AS 5070	12	125	BK 2216	3	60
AS 5578	12	125	BK 2518 RS	3	60
AS 6085	12	125	BK 2520	3	60
AS 6590	12	125	BK 2526	3	62
AS 7095	12	125	BK 2538	3	62
AS 75100	12	125	BK 3012	3	62
AS 80105	12	125	BK 3016	3	62
AS 85110	12	127	BK 3020	3	62
AS 90120	12	127	BK 3026	3	62
AS 100135	12	127	BK 3038	3	62
AS 110145	12	127	BK 3520	3	62
AS 120155	12	127	BK 4020	3	62
AS 130170	12	127	BK 4520	3	64
AS 140180	12	127	G 4×8×2	22	216
AS 150190	12	127	G 5×9×2	22	216
AS 160200	12	127	G 5×10×2	22	216
AXK 0414 TN	10	124	G 6×10×2	22	216
AXK 0515 TN	10	124	G 6×12×2	22	216
AXK 0619 TN	10	124	G 7×11×2	22	216
AXK 0821 TN	10	124	G 7×14×2	22	216
AXK 1024	10	124	G 8×12×3	22	216
AXK 1226	10	124	G 8×15×3	22	216
AXK 1528	10	124	G 9×13×3	22	216
AXK 1730	10	124	G 9×16×3	22	216
AXK 2035	10	124	G 10×14×3	22	216
AXK 2542	10	124	G 10×17×3	22	216
AXK 3047	10	124	G 12×16×3	22	216
AXK 3552	10	124	G 12×18×3	22	216
AXK 4060	10	124	G 12×19×3	22	216
AXK 4565	10	124	G 13×19×3	22	216
AXK 5070	10	124	G 14×20×3	22	216
AXK 5578	10	124	G 14×21×3	22	216
AXK 6085	10	124	G 14×22×3	22	216
AXK 6590	10	124	G 15×21×3	22	216
AXK 7095	10	124	G 15×23×3	22	216
AXK 75100	10	124	G 16×22×3	22	216
AXK 80105	10	124	G 16×24×3	22	216
AXK 85110	10	126	G 16×25×3	22	216
AXK 90120	10	126	G 17×23×3	22	216
AXK 100135	10	126	G 17×25×3	22	216
AXK 110145	10	126	G 18×24×3	22	216
AXK 120155	10	126	G 18×26×4	22	216
AXK 130170	10	126	G 19×27×4	22	216
AXK 140180	10	126	G 20×26×4	22	216
AXK 150190	10	126	G 20×28×4	22	216
AXK 160200	10	126	G 21×29×4	22	216
BK 0306 TN	3	56	G 22×28×4	22	216
BK 0408	3	56	G 22×30×4	22	216
BK 0509	3	56	G 24×32×4	22	216
BK 0609	3	56	G 25×32×4	22	216
BK 0709	3	56	G 25×33×4	22	216
BK 0808	3	56	G 25×35×4	22	216
BK 0810	3	56	G 26×34×4	22	217
BK 0910	3	56	G 28×35×4	22	217
BK 0912	3	56	G 28×37×4	22	217
BK 1010	3	56	G 29×38×4	22	217
BK 1012	3	56	G 30×37×4	22	217
BK 1015	3	56	G 30×40×4	22	217
BK 1210	3	58	G 32×42×4	22	217
BK 1212	3	58	G 32×45×4	22	217
BK 1312	3	58	G 35×42×4	22	217

Designation	Code	Page	Designation	Code	Page
G 35×45×4	22	217	HK 1620.2RS	2	58
G 37×47×4	22	217	HK 1622	2	58
G 38×48×4	22	217	HK 1712	2	58
G 40×47×4	22	217	HK 1812	2	60
G 40×50×4	22	217	HK 1814 RS	2	60
G 40×52×5	22	217	HK 1816	2	60
G 42×52×4	22	217	HK 1816.2RS	2	60
G 43×53×4	22	217	HK 2010	2	60
G 45×52×4	22	217	HK 2012	2	60
G 45×55×4	22	217	HK 2016	2	60
G 50×58×4	22	217	HK 2016.2RS	2	60
G 50×62×5	22	217	HK 2018 RS	2	60
G 55×63×5	22	217	HK 2020	2	60
G 70×78×5	22	213	HK 2020.2RS	2	60
GS 81102	14	125	HK 2030	2	60
GS 81103	14	125	HK 2210	2	60
GS 81104	14	125	HK 2212	2	60
GS 81105	14	125	HK 2214 RS	2	60
GS 81106	14	125	HK 2216	2	60
GS 81107	14	125	HK 2216.2RS	2	60
GS 81108	14	125	HK 2218 RS	2	60
GS 81109	14	125	HK 2220	2	60
GS 81110	14	125	HK 2220.2RS	2	60
GS 81111	14	125	HK 2512	2	60
GS 81112	14	125	HK 2516	2	60
GS 81113	14	125	HK 2516.2RS	2	60
GS 81114	14	125	HK 2518 RS	2	60
GS 81115	14	125	HK 2520	2	60
GS 81116	14	125	HK 2520.2RS	2	60
GS 81117	14	127	HK 2524.2RS	2	60
GS 81118	14	127	HK 2526	2	60
GS 81120	14	127	HK 2530.2RS	2	62
GS 81122	14	127	HK 2538	2	62
GS 81124	14	127	HK 2816	2	62
GS 81126	14	127	HK 2820	2	62
GS 81128	14	127	HK 2820.2RS	2	62
GS 81130	14	127	HK 3012	2	62
GS 81132	14	127	HK 3016	2	62
HK 0306 TN	2	56	HK 3016.2RS	2	62
HK 0408	2	56	HK 3018 RS	2	62
HK 0509	2	56	HK 3020	2	62
HK 0608	2	56	HK 3020.2RS	2	62
HK 0609	2	56	HK 3024.2RS	2	62
HK 0709	2	56	HK 3026	2	62
HK 0808	2	56	HK 3038	2	62
HK 0810	2	56	HK 3512	2	62
HK 0810 RS	2	56	HK 3516	2	62
HK 0812.2RS	2	56	HK 3516.2RS	2	62
HK 0908	2	56	HK 3518 RS	2	62
HK 0910	2	56	HK 3520	2	62
HK 0912	2	56	HK 3520.2RS	2	62
HK 1010	2	56	HK 4012	2	62
HK 1012	2	56	HK 4016	2	62
HK 1012 RS	2	56	HK 4016.2RS	2	62
HK 1014.2RS	2	56	HK 4018 RS	2	62
HK 1015	2	56	HK 4020	2	62
HK 1210	2	58	HK 4020.2RS	2	62
HK 1212	2	58	HK 4512	2	64
HK 1214 RS	2	58	HK 4516	2	64
HK 1216.2RS	2	58	HK 4518 RS	2	64
HK 1312	2	58	HK 4520	2	64
HK 1412	2	58	HK 4520.2RS	2	64
HK 1414 RS	2	58	HK 5020	2	64
HK 1416.2RS	2	58	HK 5022 RS	2	64
HK 1512	2	58	HK 5024.2RS	2	64
HK 1514 RS	2	58	HK 5025	2	64
HK 1516	2	58	HK 5520	2	64
HK 1516.2RS	2	58	HK 5528	2	64
HK 1518 RS	2	58	HK 6012	2	64
HK 1520.2RS	2	58	HK 6020	2	64
HK 1522	2	58	HK 6032	2	64
HK 1612	2	58	IR 5×8×12	20	207
HK 1614 RS	2	58	IR 5×8×16	20	207
HK 1616	2	58	IR 6×9×12	20	207
HK 1616.2RS	2	58	IR 6×9×16	20	207



Product index

Designation	Code	Page	Designation	Code	Page
IR 6×10×10 IS1	20	207	IR 30×35×17	20	208
IR 7×10×10.5	20	207	IR 30×35×20	20	208
IR 7×10×12	20	207	IR 30×35×20.5	20	208
IR 7×10×16	20	207	IR 30×35×26	20	208
IR 8×12×10.5	20	207	IR 30×35×30	20	208
IR 8×12×12.5	20	207	IR 30×37×18	20	208
IR 8×12×10 IS1	20	207	IR 30×37×22	20	208
IR 9×12×12	20	207	IR 30×38×20 IS1	20	208
IR 9×12×16	20	207	IR 32×37×20	20	208
IR 10×13×12.5	20	207	IR 32×37×30	20	208
IR 10×14×12 IS1	20	207	IR 32×40×20	20	208
IR 10×14×13	20	207	IR 32×40×36	20	208
IR 10×14×16	20	207	IR 33×37×13	20	208
IR 10×14×20	20	207	IR 35×40×17	20	208
IR 12×15×12	20	207	IR 35×40×20	20	208
IR 12×15×12.5	20	207	IR 35×40×20.5	20	208
IR 12×15×16	20	207	IR 35×40×30	20	208
IR 12×15×16.5	20	207	IR 35×42×20 IS1	20	208
IR 12×15×22.5	20	207	IR 35×42×36	20	208
IR 12×16×12 IS1	20	207	IR 35×43×22	20	208
IR 12×16×13	20	207	IR 38×43×20	20	209
IR 12×16×16	20	207	IR 38×43×30	20	209
IR 12×16×20	20	207	IR 40×45×17	20	209
IR 12×16×22	20	207	IR 40×45×20	20	209
IR 14×17×17	20	207	IR 40×45×30	20	209
IR 15×18×16	20	207	IR 40×48×22	20	209
IR 15×18×16.5	20	207	IR 40×48×40	20	209
IR 15×19×16	20	207	IR 40×50×20 IS1	20	209
IR 15×19×20	20	207	IR 40×50×22	20	209
IR 15×20×12 IS1	20	207	IR 42×47×20	20	209
IR 15×20×13	20	207	IR 42×47×30	20	209
IR 15×20×23	20	207	IR 45×50×25	20	209
IR 17×20×16	20	207	IR 45×50×25.5	20	209
IR 17×20×16.5	20	207	IR 45×50×35	20	209
IR 17×20×20	20	207	IR 45×52×22	20	209
IR 17×20×20.5	20	207	IR 45×52×40	20	209
IR 17×20×30.5	20	207	IR 45×55×20 IS1	20	209
IR 17×21×16	20	207	IR 45×55×22	20	209
IR 17×21×20	20	207	IR 50×55×20 IS1	20	209
IR 17×22×13	20	207	IR 50×55×25	20	209
IR 17×22×16	20	207	IR 50×55×35	20	209
IR 17×22×23	20	207	IR 50×58×22	20	209
IR 17×24×20	20	207	IR 50×58×40	20	209
IR 20×24×16	20	208	IR 50×60×20 IS1	20	209
IR 20×24×20	20	208	IR 50×60×25	20	209
IR 20×25×16 IS1	20	208	IR 50×60×28	20	209
IR 20×25×17	20	208	IR 55×60×25	20	209
IR 20×25×20	20	208	IR 55×60×35	20	209
IR 20×25×20.5	20	208	IR 55×63×25	20	209
IR 20×25×26.5	20	208	IR 55×63×45	20	209
IR 20×25×30	20	208	IR 55×65×28	20	209
IR 20×25×38.5	20	208	IR 60×68×25	20	209
IR 20×28×20	20	208	IR 60×68×35	20	209
IR 22×26×16	20	208	IR 60×68×45	20	209
IR 22×26×20	20	208	IR 60×70×25	20	209
IR 22×28×17	20	208	IR 60×70×28	20	209
IR 22×28×20	20	208	IR 65×72×25	20	209
IR 22×28×20.5	20	208	IR 65×72×45	20	209
IR 22×28×30	20	208	IR 65×73×25	20	209
IR 25×29×20	20	208	IR 65×73×35	20	209
IR 25×29×30	20	208	IR 65×75×28	20	209
IR 25×30×16 IS1	20	208	IR 70×80×25	20	209
IR 25×30×17	20	208	IR 70×80×30	20	209
IR 25×30×20	20	208	IR 70×80×35	20	209
IR 25×30×20.5	20	208	IR 70×80×54	20	209
IR 25×30×26.5	20	208	IR 75×85×25	20	209
IR 25×30×30	20	208	IR 75×85×30	20	209
IR 25×30×32	20	208	IR 75×85×35	20	209
IR 25×30×38.5	20	208	IR 75×85×54	20	209
IR 25×32×22	20	208	IR 80×90×25	20	209
IR 28×32×17	20	208	IR 80×90×30	20	209
IR 28×32×20	20	208	IR 80×90×35	20	209
IR 28×32×30	20	208	IR 80×90×54	20	209
IR 30×35×13	20	208	IR 85×95×26	20	209
IR 30×35×16	20	208	IR 85×95×36	20	209

Designation	Code	Page	Designation	Code	Page
IR 85×100×35	20	209	K 10×16×12 TN	1	40
IR 85×100×63	20	209	K 12×15×10 TN	1	40
IR 90×100×26	20	210	K 12×15×13 TN	1	40
IR 90×100×30	20	210	K 12×16×13 TN	1	40
IR 90×100×36	20	210	K 12×17×13 TN	1	40
IR 90×105×35	20	210	K 12×18×12 TN	1	40
IR 90×105×63	20	210	K 14×18×10	1	41
IR 95×105×26	20	210	K 14×18×13	1	41
IR 95×105×36	20	210	K 14×18×17	1	41
IR 95×110×35	20	210	K 14×20×12	1	41
IR 95×110×63	20	210	K 15×18×17 TN	1	41
IR 100×110×30	20	210	K 15×19×10	1	41
IR 100×110×40	20	210	K 15×19×13	1	41
IR 100×115×40	20	210	K 15×19×17	1	41
IR 110×120×30	20	210	K 15×20×13	1	41
IR 110×125×40	20	210	K 15×21×15	1	41
IR 120×130×30	20	210	K 15×21×21	1	41
IR 120×135×45	20	210	K 16×20×10	1	41
IR 130×145×35	20	210	K 16×20×13	1	41
IR 130×150×50	20	210	K 16×20×17	1	41
IR 140×155×35	20	210	K 16×22×12	1	41
IR 140×160×50	20	210	K 16×22×16	1	41
IR 150×165×40	20	210	K 16×22×20	1	41
IR 160×175×40	20	210	K 16×24×20	1	41
IR 170×185×45	20	210	K 17×21×10	1	41
IR 180×195×45	20	210	K 17×21×13	1	41
IR 190×210×50	20	210	K 17×21×17	1	41
IR 200×220×50	20	210	K 18×22×10	1	41
IR 220×240×50	20	210	K 18×22×13	1	41
IR 240×265×60	20	210	K 18×22×17	1	41
IR 260×285×60	20	210	K 18×24×12	1	41
IR 280×305×69	20	210	K 18×24×13	1	41
IR 300×330×80	20	210	K 18×24×20	1	41
IR 320×350×80	20	210	K 18×25×22	1	41
IR 340×370×80	20	210	K 18×28×16	1	41
IR 360×390×80	20	210	K 19×23×13	1	41
IR 380×415×100	20	210	K 19×23×17	1	41
IRZ 6×10×12 IS1	20	207	K 20×24×10	1	42
IRZ 8×12×12 IS1	20	207	K 20×24×13	1	42
IRZ 10×14×14 IS1	20	207	K 20×24×17	1	42
IRZ 12×16×14 IS1	20	207	K 20×26×12	1	42
IRZ 15×20×14 IS1	20	207	K 20×26×13	1	42
IRZ 17×22×14 IS1	20	207	K 20×26×17	1	42
IRZ 20×25×18 IS1	20	208	K 20×26×20	1	42
IRZ 25×30×18 IS1	20	208	K 20×28×20	1	42
IRZ 30×35×18 IS1	20	208	K 20×28×25	1	42
IRZ 35×42×21 IS1	20	208	K 20×30×30	1	42
IRZ 35×42×23 IS1	20	208	K 21×25×13	1	42
IRZ 40×48×23 IS1	20	209	K 22×26×10	1	42
IRZ 45×52×23 IS1	20	209	K 22×26×13	1	42
IRZ 50×58×23 IS1	20	209	K 22×26×17	1	42
K 3×5×7 TN	1	40	K 22×28×17	1	42
K 3×5×9 TN	1	40	K 22×29×16	1	42
K 3×6×7 TN	1	40	K 22×30×15 TN	1	42
K 4×7×7 TN	1	40	K 23×35×16 TN	1	42
K 4×7×10 TN	1	40	K 24×28×10	1	42
K 5×8×8 TN	1	40	K 24×28×13	1	42
K 5×8×10 TN	1	40	K 24×28×17	1	42
K 6×9×8 TN	1	40	K 24×30×17	1	42
K 6×9×10 TN	1	40	K 24×30×31 ZW	1	42
K 6×10×13 TN	1	40	K 25×29×10	1	42
K 7×9×7 TN	1	40	K 25×29×13	1	42
K 7×10×8 TN	1	40	K 25×29×17	1	42
K 7×10×10 TN	1	40	K 25×30×17	1	42
K 8×11×8 TN	1	40	K 25×30×20	1	42
K 8×11×10 TN	1	40	K 25×30×26 ZW	1	42
K 8×11×13 TN	1	40	K 25×31×17	1	42
K 8×12×10 TN	1	40	K 25×31×21	1	42
K 9×12×10 TN	1	40	K 25×32×16	1	42
K 9×12×13 TN	1	40	K 25×33×20	1	42
K 10×13×10 TN	1	40	K 25×33×24	1	42
K 10×13×13 TN	1	40	K 25×35×30	1	42
K 10×13×16 TN	1	40	K 26×30×13	1	43
K 10×14×10 TN	1	40	K 26×30×17	1	43
K 10×14×13 TN	1	40	K 26×30×22 ZW	1	43



Product index

Designation	Code	Page	Designation	Code	Page
K 28×33×13	1	43	K 58×65×36 ZW	1	45
K 28×33×17	1	43	K 60×65×20	1	45
K 28×34×17	1	43	K 60×65×30	1	45
K 28×35×16	1	43	K 60×66×33 ZW	1	45
K 28×35×18	1	43	K 60×66×40 ZW	1	45
K 30×34×13	1	43	K 60×68×20	1	45
K 30×35×13	1	43	K 60×68×23	1	45
K 30×35×17	1	43	K 60×68×25	1	45
K 30×35×27	1	43	K 60×68×30 ZW	1	45
K 30×37×16	1	43	K 60×75×42	1	45
K 30×37×18	1	43	K 62×70×40 ZW	1	45
K 30×40×18	1	43	K 64×70×16	1	45
K 30×40×30	1	43	K 65×70×20	1	45
K 32×37×13	1	43	K 65×70×30	1	45
K 32×37×17	1	43	K 65×73×23	1	45
K 32×37×27	1	43	K 65×73×30	1	45
K 32×38×20	1	43	K 68×74×20	1	46
K 32×39×16	1	43	K 68×74×30	1	46
K 32×39×18	1	43	K 70×76×20	1	46
K 32×40×25	1	43	K 70×76×30	1	46
K 35×40×13	1	43	K 70×78×25	1	46
K 35×40×17	1	43	K 70×78×30	1	46
K 35×40×25	1	43	K 72×80×20	1	46
K 35×40×27 TN	1	43	K 73×79×20	1	46
K 35×42×16	1	43	K 75×81×20	1	46
K 35×42×18	1	43	K 75×81×30	1	46
K 35×42×20	1	43	K 75×83×23	1	46
K 35×42×30	1	43	K 75×83×30	1	46
K 35×45×20	1	43	K 80×86×20	1	46
K 37×42×17	1	43	K 80×86×30	1	46
K 37×45×26	1	43	K 80×88×30	1	46
K 38×43×17	1	44	K 85×92×20	1	46
K 38×43×27	1	44	K 90×97×20	1	46
K 38×46×20	1	44	K 90×98×27	1	46
K 38×46×32	1	44	K 90×98×30	1	46
K 39×44×26 ZW	1	44	K 95×103×30	1	46
K 40×45×13	1	44	K 100×107×21	1	46
K 40×45×17	1	44	K 100×108×27	1	46
K 40×45×27	1	44	K 100×108×30	1	46
K 40×47×18	1	44	K 105×112×21	1	46
K 40×48×20	1	44	K 110×117×24	1	46
K 42×47×13	1	44	K 110×118×30	1	46
K 42×47×17	1	44	K 115×123×27	1	46
K 42×47×30 ZW	1	44	K 120×127×24	1	47
K 42×50×20	1	44	K 125×133×35	1	47
K 43×48×17	1	44	K 130×137×24	1	47
K 43×48×27	1	44	K 135×143×35	1	47
K 45×50×17	1	44	K 145×153×26	1	47
K 45×50×27	1	44	K 145×153×36	1	47
K 45×52×18	1	44	K 150×160×46	1	47
K 45×52×21 TN	1	44	K 155×163×26	1	47
K 45×53×20	1	44	K 155×163×36	1	47
K 45×53×21	1	44	K 160×170×46	1	47
K 45×53×28	1	44	K 165×173×26	1	47
K 45×59×18 TN	1	44	K 175×183×32	1	47
K 47×52×17	1	44	K 185×195×37	1	47
K 47×52×27	1	44	K 195×205×37	1	47
K 47×53×25	1	44	K 210×220×42	1	47
K 50×55×13.5	1	45	K 220×230×42	1	47
K 50×55×17	1	45	K 240×250×42	1	47
K 50×55×20	1	45	K 265×280×50	1	47
K 50×55×30	1	45	KR 16	19	192
K 50×57×18	1	45	KR 16 PP	19	192
K 50×58×20	1	45	KR 16 PPA	19	192
K 50×58×25	1	45	KR 16 PPSK	19	192
K 52×57×12	1	45	KR 16 PPSKA	19	192
K 55×60×20	1	45	KR 19	19	192
K 55×60×27	1	45	KR 19 PP	19	192
K 55×60×30	1	45	KR 19 PPA	19	192
K 55×62×18	1	45	KR 19 PPSK	19	192
K 55×63×15	1	45	KR 19 PPSKA	19	192
K 55×63×20	1	45	KR 22	19	192
K 55×63×25	1	45	KR 22 B	19	192
K 55×63×32	1	45	KR 22 PP	19	192
K 58×65×18	1	45	KR 22 PPA	19	192

Designation	Code	Page	Designation	Code	Page
KR 26	19	194	KRV 40 PPA	19	196
KR 26 B	19	194	KRV 47 PP	19	198
KR 26 PP	19	194	KRV 47 PPA	19	198
KR 26 PPA	19	194	KRV 52 PP	19	198
KR 30	19	194	KRV 52 PPA	19	198
KR 30 B	19	194	KRV 62 PPB	19	198
KR 30 PP	19	194	KRV 62 PPA	19	198
KR 30 PPA	19	194	KRV 72 PPB	19	200
KR 32	19	194	KRV 72 PPA	19	200
KR 32 B	19	194	KRV 80 PPB	19	200
KR 32 PP	19	194	KRV 80 PPA	19	200
KR 32 PPA	19	194	KRV 90 PPB	19	200
KR 35	19	196	KRV 90 PPA	19	200
KR 35 B	19	196	LR 7×10×10.5	20	207
KR 35 PP	19	196	LR 8×12×10.5	20	207
KR 35 PPA	19	196	LR 8×12×12.5	20	207
KR 40	19	196	LR 10×13×12.5	20	207
KR 40 B	19	196	LR 12×15×12.5	20	207
KR 40 PP	19	196	LR 12×15×16.5	20	207
KR 40 PPA	19	196	LR 12×15×22.5	20	207
KR 47 PP	19	198	LR 15×18×12.5	20	207
KR 47 PPA	19	198	LR 15×18×16.5	20	207
KR 52 PP	19	198	LR 17×20×16.5	20	207
KR 52 PPA	19	198	LR 17×20×20.5	20	207
KR 62 PPB	19	198	LR 17×20×30.5	20	207
KR 62 PPA	19	198	LR 20×25×12.5	20	208
KR 72 PPB	19	200	LR 20×25×16.5	20	208
KR 72 PPA	19	200	LR 20×25×20.5	20	208
KR 80 PPB	19	200	LR 20×25×26.5	20	208
KR 80 PPA	19	200	LR 20×25×38.5	20	208
KR 90 PPB	19	200	LR 22×28×20.5	20	208
KR 90 PPA	19	200	LR 25×30×12.5	20	208
KRE 16 PP	19	192	LR 25×30×16.5	20	208
KRE 16 PPA	19	192	LR 25×30×20.5	20	208
KRE 19 PP	19	192	LR 25×30×26.5	20	208
KRE 19 PPA	19	192	LR 25×30×38.5	20	208
KRE 22 PP	19	192	LR 30×35×12.5	20	208
KRE 22 PPA	19	192	LR 30×35×16.5	20	208
KRE 26 PP	19	194	LR 30×35×20.5	20	208
KRE 26 PPA	19	194	LR 35×40×12.5	20	208
KRE 30 PP	19	194	LR 35×40×16.5	20	208
KRE 30 PPA	19	194	LR 35×40×20.5	20	208
KRE 32 PP	19	194	LR 40×45×16.5	20	209
KRE 32 PPA	19	194	LR 40×45×20.5	20	209
KRE 35 PP	19	196	LR 45×50×20.5	20	209
KRE 35 PPA	19	196	LR 45×50×25.5	20	209
KRE 40 PP	19	196	LR 50×55×20.5	20	209
KRE 40 PPA	19	196	LS 0619	11	125
KRE 47 PP	19	198	LS 0821	11	125
KRE 47 PPA	19	198	LS 1024	11	125
KRE 52 PP	19	198	LS 1226	11	125
KRE 52 PPA	19	198	LS 1528	11	125
KRE 62 PPB	19	198	LS 1730	11	125
KRE 62 PPA	19	198	LS 2035	11	125
KRE 72 PPB	19	200	LS 2542	11	125
KRE 80 PPA	19	200	LS 3047	11	125
KRE 80 PPB	19	200	LS 3552	11	125
KRE 90 PPA	19	200	LS 4060	11	125
KRE 90 PPB	19	200	LS 4565	11	125
KRE 72 PPA	19	200	LS 5070	11	125
KRV 16 PP	19	192	LS 5578	11	125
KRV 16 PPA	19	192	LS 6085	11	125
KRV 19 PP	19	192	LS 6590	11	125
KRV 19 PPA	19	192	LS 7095	11	125
KRV 22 PP	19	192	LS 75100	11	125
KRV 22 PPA	19	192	LS 80105	11	125
KRV 26 PP	19	194	LS 85110	11	127
KRV 26 PPA	19	194	LS 90120	11	127
KRV 30 PP	19	194	LS 100135	11	127
KRV 30 PPA	19	194	LS 110145	11	127
KRV 32 PP	19	194	LS 120155	11	127
KRV 32 PPA	19	194	LS 130170	11	127
KRV 35 PP	19	196	LS 140180	11	127
KRV 35 PPA	19	196	LS 150190	11	127
KRV 40 PP	19	196	LS 160200	11	127

Product index

Designation	Code	Page	Designation	Code	Page
NA 22/6.2RS	18	170	NA 4918	5	96
NA 22/8.2RS	18	170	NA 4919	5	96
NA 2200.2RS	18	170	NA 4920	5	96
NA 2201.2RS	18	170	NA 4922	5	96
NA 2202.2RS	18	170	NA 4924	5	96
NA 2203.2RS	18	170	NA 4926	5	96
NA 2204.2RS	18	170	NA 4928	5	96
NA 2205.2RS	18	170	NA 69/22	5	90
NA 2206.2RS	18	170	NA 69/28	5	90
NA 2207.2RS	18	170	NA 69/32	5	90
NA 2208.2RS	18	170	NA 6901	5	88
NA 2209.2RS	18	170	NA 6902	5	88
NA 2210.2RS	18	170	NA 6903	5	88
NA 4822	5	96	NA 6904	5	90
NA 4824	5	96	NA 6905	5	90
NA 4826	5	96	NA 6906	5	90
NA 4828	5	96	NA 6907	5	92
NA 4830	5	96	NA 6908	5	92
NA 4832	5	96	NA 6909	5	92
NA 4834	5	96	NA 6910	5	92
NA 4836	5	96	NA 6911	5	94
NA 4838	5	96	NA 6912	5	94
NA 4840	5	96	NA 6913	5	94
NA 4844	5	96	NA 6914	5	94
NA 4848	5	98	NA 6915	5	94
NA 4852	5	98	NA 6916	5	94
NA 4856	5	98	NA 6917	5	94
NA 4860	5	98	NA 6918	5	96
NA 4864	5	98	NA 6919	5	96
NA 4868	5	98	NAO 6×17×10 TN	7	104
NA 4872	5	98	NAO 9×22×12 TN	7	104
NA 4876	5	98	NAO 12×24×13	7	104
NA 49/22	5	90	NAO 12×28×12	7	104
NA 49/28	5	90	NAO 15×28×13	7	104
NA 49/32	5	90	NAO 15×32×12	7	104
NA 4900	5	88	NAO 17×30×13	7	104
NA 4900 RS	5	88	NAO 17×35×16	7	104
NA 4900.2RS	5	88	NAO 20×35×17	7	104
NA 4901	5	88	NAO 20×37×16	7	104
NA 4901 RS	5	88	NAO 25×40×17	7	104
NA 4901.2RS	5	88	NAO 25×42×16	7	104
NA 4902	5	88	NAO 25×42×32	7	104
NA 4902 RS	5	88	NAO 30×45×17	7	104
NA 4902.2RS	5	88	NAO 30×45×26	7	104
NA 4903	5	88	NAO 30×47×16	7	104
NA 4903 RS	5	88	NAO 30×47×18	7	104
NA 4903.2RS	5	88	NAO 35×50×17	7	104
NA 4904	5	90	NAO 35×55×20	7	104
NA 4904 RS	5	90	NAO 40×55×17	7	104
NA 4904.2RS	5	90	NAO 50×68×20	7	104
NA 4905	5	90	NAO 70×100×30	7	104
NA 4905 RS	5	90	NAO 80×110×30	7	104
NA 4905.2RS	5	90	NAO 90×120×30	7	104
NA 4906	5	90	NATR 5	18	172
NA 4906 RS	5	90	NATR 5 PP	18	172
NA 4906.2RS	5	90	NATR 5 PPA	18	172
NA 4907	5	92	NATR 6	18	172
NA 4907 RS	5	92	NATR 6 PP	18	172
NA 4907.2RS	5	92	NATR 6 PPA	18	172
NA 4908	5	92	NATR 8	18	172
NA 4908 RS	5	92	NATR 8 PP	18	172
NA 4908.2RS	5	92	NATR 8 PPA	18	172
NA 4909	5	92	NATR 10	18	172
NA 4909 RS	5	92	NATR 10 PP	18	172
NA 4909.2RS	5	92	NATR 10 PPA	18	172
NA 4910	5	92	NATR 12	18	172
NA 4910 RS	5	92	NATR 12 PP	18	172
NA 4910.2RS	5	92	NATR 12 PPA	18	172
NA 4911	5	94	NATR 15	18	174
NA 4912	5	94	NATR 15 PP	18	174
NA 4913	5	94	NATR 15 PPA	18	174
NA 4914	5	94	NATR 17	18	174
NA 4915	5	94	NATR 17 PP	18	174
NA 4916	5	94	NATR 17 PPA	18	174
NA 4917	5	94	NATR 20	18	174

Designation	Code	Page	Designation	Code	Page
NATR 20 PP	18	174	NK 19/20	4	76
NATR 20 PPA	18	174	NK 20/16	4	76
NATR 25	18	174	NK 20/20	4	76
NATR 25 PP	18	174	NK 21/16	4	76
NATR 25 PPA	18	174	NK 21/20	4	76
NATR 30	18	176	NK 22/16	4	76
NATR 30 PP	18	176	NK 22/20	4	76
NATR 30 PPA	18	176	NK 24/16	4	76
NATR 35 PP	18	176	NK 24/20	4	76
NATR 35 PPA	18	176	NK 25/16	4	76
NATR 40 PP	18	176	NK 25/20	4	76
NATR 40 PPA	18	176	NK 26/16	4	76
NATR 50 PP	18	176	NK 26/20	4	76
NATR 50 PPA	18	176	NK 28/20	4	78
NATV 5	18	172	NK 28/30	4	78
NATV 5 PP	18	172	NK 29/20	4	78
NATV 5 PPA	18	172	NK 29/30	4	78
NATV 6	18	172	NK 30/20	4	78
NATV 6 PP	18	172	NK 30/30	4	78
NATV 6 PPA	18	172	NK 32/20	4	78
NATV 8	18	172	NK 32/30	4	78
NATV 8 PP	18	172	NK 35/20	4	78
NATV 8 PPA	18	172	NK 35/30	4	78
NATV 10	18	172	NK 37/20	4	78
NATV 10 PP	18	172	NK 37/30	4	78
NATV 10 PPA	18	172	NK 38/20	4	78
NATV 12	18	172	NK 38/30	4	78
NATV 12 PP	18	172	NK 40/20	4	80
NATV 12 PPA	18	172	NK 40/30	4	80
NATV 15	18	174	NK 42/20	4	80
NATV 15 PP	18	174	NK 42/30	4	80
NATV 15 PPA	18	174	NK 43/20	4	80
NATV 17	18	174	NK 43/30	4	80
NATV 17 PP	18	174	NK 45/20	4	80
NATV 17 PPA	18	174	NK 45/30	4	80
NATV 20	18	174	NK 47/20	4	80
NATV 20 PP	18	174	NK 47/30	4	80
NATV 20 PPA	18	174	NK 50/25	4	80
NATV 25	18	174	NK 50/35	4	80
NATV 25 PP	18	174	NK 55/25	4	80
NATV 25 PPA	18	174	NK 55/35	4	80
NATV 30	18	176	NK 60/25	4	82
NATV 30 PP	18	176	NK 60/35	4	82
NATV 30 PPA	18	176	NK 65/25	4	82
NATV 35 PP	18	176	NK 65/35	4	82
NATV 35 PPA	18	176	NK 68/25	4	82
NATV 40 PP	18	176	NK 68/35	4	82
NATV 40 PPA	18	176	NK 70/25	4	82
NATV 50 PP	18	176	NK 70/35	4	82
NATV 50 PPA	18	176	NK 73/25	4	82
NK 5/10 TN	4	74	NK 73/35	4	82
NK 5/12 TN	4	74	NK 75/25	4	82
NK 6/10 TN	4	74	NK 75/35	4	82
NK 6/12 TN	4	74	NK 80/25	4	82
NK 7/10 TN	4	74	NK 80/35	4	82
NK 7/12 TN	4	74	NK 85/25	4	84
NK 8/12 TN	4	74	NK 85/35	4	84
NK 8/16 TN	4	74	NK 90/25	4	84
NK 9/12 TN	4	74	NK 90/35	4	84
NK 9/16 TN	4	74	NK 95/26	4	84
NK 10/12 TN	4	74	NK 95/36	4	84
NK 10/16 TN	4	74	NK 100/26	4	84
NK 12/12	4	74	NK 100/36	4	84
NK 12/16	4	74	NK 105/26	4	84
NK 14/16	4	74	NK 105/36	4	84
NK 14/20	4	74	NK 110/30	4	84
NK 15/16	4	74	NK 110/40	4	84
NK 15/20	4	74	NK1 5/12 TN	5	88
NK 16/16	4	74	NK1 5/16 TN	5	88
NK 16/20	4	74	NK1 6/12 TN	5	88
NK 17/16	4	74	NK1 6/16 TN	5	88
NK 17/20	4	74	NK1 7/12 TN	5	88
NK 18/16	4	76	NK1 7/16 TN	5	88
NK 18/20	4	76	NK1 9/12	5	88
NK 19/16	4	76	NK1 9/16	5	88



Product index

Designation	Code	Page	Designation	Code	Page
NKI 10/16	5	88	NKIB 5908	15	134
NKI 10/20	5	88	NKIB 5909	15	134
NKI 12/16	5	88	NKIB 5910	15	134
NKI 12/20	5	88	NKIB 5911	15	134
NKI 15/16	5	88	NKIB 5912	15	134
NKI 15/20	5	88	NKIB 5913	15	136
NKI 17/16	5	88	NKIB 5914	15	136
NKI 17/20	5	88	NKIS 17	5	88
NKI 20/16	5	90	NKIS 20	5	90
NKI 20/20	5	90	NKIS 25	5	90
NKI 22/16	5	90	NKIS 30	5	90
NKI 22/20	5	90	NKIS 35	5	92
NKI 25/20	5	90	NKIS 40	5	92
NKI 25/30	5	90	NKIS 45	5	92
NKI 28/20	5	90	NKIS 50	5	92
NKI 28/30	5	90	NKIS 55	5	94
NKI 30/20	5	90	NKIS 60	5	94
NKI 30/30	5	90	NKIS 65	5	94
NKI 32/20	5	90	NKS 24	4	76
NKI 32/30	5	90	NKS 25	4	76
NKI 35/20	5	92	NKS 28	4	78
NKI 35/30	5	92	NKS 30	4	78
NKI 38/20	5	92	NKS 32	4	78
NKI 38/30	5	92	NKS 35	4	78
NKI 40/20	5	92	NKS 37	4	78
NKI 40/30	5	92	NKS 40	4	80
NKI 42/20	5	92	NKS 43	4	80
NKI 42/30	5	92	NKS 45	4	80
NKI 45/25	5	92	NKS 50	4	80
NKI 45/35	5	92	NKS 55	4	80
NKI 50/25	5	92	NKS 60	4	82
NKI 50/35	5	92	NKS 65	4	82
NKI 55/25	5	94	NKS 70	4	82
NKI 55/35	5	94	NKS 75	4	82
NKI 60/25	5	94	NKX 10 TN	16	148
NKI 60/35	5	94	NKX 10 ZTN	16	148
NKI 65/25	5	94	NKX 12	16	148
NKI 65/35	5	94	NKX 12 Z	16	148
NKI 70/25	5	94	NKX 15	16	148
NKI 70/35	5	94	NKX 15 Z	16	148
NKI 75/25	5	94	NKX 17	16	148
NKI 75/35	5	94	NKX 17 Z	16	148
NKI 80/25	5	94	NKX 20	16	148
NKI 80/35	5	94	NKX 20 Z	16	148
NKI 85/26	5	94	NKX 25	16	148
NKI 85/36	5	94	NKX 25 Z	16	148
NKI 90/26	5	96	NKX 30	16	148
NKI 90/36	5	96	NKX 30 Z	16	148
NKI 95/26	5	96	NKX 35	16	148
NKI 95/36	5	96	NKX 35 Z	16	148
NKI 100/30	5	96	NKX 40	16	148
NKI 100/40	5	96	NKX 40 Z	16	148
NKIA 59/22	15	134	NKX 45	16	148
NKIA 5901	15	134	NKX 45 Z	16	148
NKIA 5902	15	134	NKX 50	16	148
NKIA 5903	15	134	NKX 50 Z	16	148
NKIA 5904	15	134	NKX 60	16	148
NKIA 5905	15	134	NKX 60 Z	16	148
NKIA 5906	15	134	NKX 70	16	148
NKIA 5907	15	134	NKX 70 Z	16	148
NKIA 5908	15	134	NKXR 15	17	156
NKIA 5909	15	134	NKXR 15 Z	17	156
NKIA 5910	15	134	NKXR 17	17	156
NKIA 5911	15	134	NKXR 17 Z	17	156
NKIA 5912	15	134	NKXR 20	17	156
NKIA 5913	15	136	NKXR 20 Z	17	156
NKIA 5914	15	136	NKXR 25	17	156
NKIB 59/22	15	134	NKXR 25 Z	17	156
NKIB 5901	15	134	NKXR 30	17	156
NKIB 5902	15	134	NKXR 30 Z	17	156
NKIB 5903	15	134	NKXR 35	17	156
NKIB 5904	15	134	NKXR 35 Z	17	156
NKIB 5905	15	134	NKXR 40	17	156
NKIB 5906	15	134	NKXR 40 Z	17	156
NKIB 5907	15	134	NKXR 45	17	156

Designation	Code	Page	Designation	Code	Page
NKXR 45 Z	17	156	PWKR 35.2RS	19	196
NKXR 50	17	156	PWKR 40.2RS	19	196
NKXR 50 Z	17	156	PWKR 47.2RS	19	198
NNTR 50×130×65.2ZL	18	178	PWKR 52.2RS	19	198
NNTR 55×140×70.2ZL	18	178	PWKR 62.2RS	19	198
NNTR 60×150×75.2ZL	18	178	PWKR 72.2RS	19	200
NNTR 65×160×75.2ZL	18	178	PWKR 80.2RS	19	200
NNTR 70×180×85.2ZL	18	178	PWKR 90.2RS	19	200
NNTR 80×200×90.2ZL	18	178	PWKRE 35.2RS	19	196
NNTR 90×220×100.2ZL	18	178	PWKRE 40.2RS	19	196
NNTR 100×240×105.2ZL	18	178	PWKRE 47.2RS	19	198
NNTR 110×260×115.2ZL	18	178	PWKRE 52.2RS	19	198
NNTR 120×290×135.2ZL	18	178	PWKRE 62.2RS	19	198
NNTR 130×310×146.2ZL	18	178	PWKRE 72.2RS	19	200
NUKR 35 A	19	196	PWKRE 80.2RS	19	200
NUKR 40 A	19	196	PWKRE 90.2RS	19	200
NUKR 47 A	19	198	PWTR 15.2RS	18	174
NUKR 52 A	19	198	PWTR 17.2RS	18	174
NUKR 62 A	19	198	PWTR 20.2RS	18	174
NUKR 72 A	19	200	PWTR 25.2RS	18	174
NUKR 80 A	19	200	PWTR 30.2RS	18	176
NUKR 90 A	19	200	PWTR 35.2RS	18	176
NUKRE 35 A	19	196	PWTR 40.2RS	18	176
NUKRE 40 A	19	196	PWTR 45.2RS	18	176
NUKRE 47 A	19	198	PWTR 50.2RS	18	176
NUKRE 52 A	19	198	PWTR 1542.2RS	18	174
NUKRE 62 A	19	198	PWTR 1747.2RS	18	174
NUKRE 72 A	19	200	PWTR 2052.2RS	18	174
NUKRE 80 A	19	200	PWTR 2562.2RS	18	176
NUKRE 90 A	19	200	PWTR 3072.2RS	18	176
NUTR 15 A	18	174	PWTR 3580.2RS	18	176
NUTR 17 A	18	174	PWTR 4090.2RS	18	176
NUTR 20 A	18	174	PWTR 45100.2RS	18	178
NUTR 25 A	18	174	PWTR 50110.2RS	18	178
NUTR 30 A	18	176	RN-1×7.8 BF	21	212
NUTR 35 A	18	176	RN-1.5×5.8 BF	21	212
NUTR 40 A	18	176	RN-1.5×6.8 BF	21	212
NUTR 45 A	18	176	RN-1.5×7.8 BF	21	212
NUTR 50 A	18	176	RN-1.5×9.8 BF	21	212
NUTR 1542 A	18	176	RN-1.5×11.8 BF	21	212
NUTR 1747 A	18	176	RN-1.5×13.8 BF	21	212
NUTR 2052 A	18	176	RN-2×6.3 BF	21	212
NUTR 2562 A	18	176	RN-2×7.8 BF	21	212
NUTR 3072 A	18	176	RN-2×9.8 BF	21	212
NUTR 3580 A	18	176	RN-2×11.8 BF	21	212
NUTR 4090 A	18	176	RN-2×13.8 BF	21	212
NUTR 45100 A	18	178	RN-2×15.8 BF	21	212
NUTR 50110 A	18	178	RN-2×17.8 BF	21	212
NX 7 TN	16	146	RN-2×19.8 BF	21	212
NX 7 ZTN	16	146	RN-2×21.8 BF	21	212
NX 10	16	146	RN-2.5×7.8 BF	21	212
NX 10 Z	16	146	RN-2.5×9.8 BF	21	212
NX 12	16	146	RN-2.5×11.8 BF	21	212
NX 12 Z	16	146	RN-2.5×13.8 BF	21	212
NX 15	16	146	RN-2.5×15.8 BF	21	212
NX 15 Z	16	146	RN-2.5×17.8 BF	21	212
NX 17	16	146	RN-2.5×19.8 BF	21	212
NX 17 Z	16	146	RN-2.5×21.8 BF	21	212
NX 20	16	146	RN-2.5×23.8 BF	21	212
NX 20 Z	16	146	RN-3×9.8 BF	21	212
NX 25	16	146	RN-3×11.8 BF	21	212
NX 25 Z	16	146	RN-3×13.8 BF	21	212
NX 30	16	146	RN-3×15.8 BF	21	212
NX 30 Z	16	146	RN-3×17.8 BF	21	212
NX 35	16	146	RN-3×19.8 BF	21	212
NX 35 Z	16	146	RN-3×21.8 BF	21	212
PNA 12/28	9	114	RN-3×23.8 BF	21	212
PNA 15/32	9	114	RN-3.5×11.8 BF	21	213
PNA 17/35	9	114	RN-3.5×13.8 BF	21	213
PNA 20/42	9	114	RN-3.5×15.8 BF	21	213
PNA 22/44	9	114	RN-3.5×17.8 BF	21	213
PNA 25/47	9	114	RN-3.5×19.8 BF	21	213
PNA 30/52	9	114	RN-3.5×21.8 BF	21	213
PNA 35/55	9	114	RN-3.5×29.8 BF	21	213
PNA 40/62	9	114	RN-3.5×34.8 BF	21	213

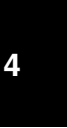

Product index

Designation	Code	Page	Designation	Code	Page
RN-4×11.8 BF	21	213	RNA 4906	4	78
RN-4×13.8 BF	21	213	RNA 4906 RS	4	78
RN-4×15.8 BF	21	213	RNA 4906.2RS	4	78
RN-4×17.8 BF	21	213	RNA 4907	4	80
RN-4×19.8 BF	21	213	RNA 4907 RS	4	80
RN-4×21.8 BF	21	213	RNA 4907.2RS	4	80
RN-4×23.8 BF	21	213	RNA 4908	4	80
RN-4×25.8 BF	21	213	RNA 4908 RS	4	80
RN-4×27.8 BF	21	213	RNA 4908.2RS	4	80
RN-4×29.8 BF	21	213	RNA 4909	4	80
RN-4×34.8 BF	21	213	RNA 4909 RS	4	80
RN-4×39.8 BF	21	213	RNA 4909.2RS	4	80
RN-5×15.8 BF	21	213	RNA 4910	4	82
RN-5×19.8 BF	21	213	RNA 4910 RS	4	82
RN-5×21.8 BF	21	213	RNA 4910.2RS	4	82
RN-5×23.8 BF	21	213	RNA 4911	4	82
RN-5×25.8 BF	21	213	RNA 4912	4	82
RN-5×27.8 BF	21	213	RNA 4913	4	82
RN-5×29.8 BF	21	213	RNA 4914	4	82
RN-5×34.8 BF	21	213	RNA 4915	4	84
RN-5×39.8 BF	21	213	RNA 4916	4	84
RN-6×17.8 BF	21	213	RNA 4917	4	84
RNA 22/6.2RS	18	168	RNA 4918	4	84
RNA 22/8.2RS	18	168	RNA 4919	4	84
RNA 2200.2RS	18	168	RNA 4920	4	84
RNA 2201.2RS	18	168	RNA 4922	4	84
RNA 2202.2RS	18	168	RNA 4924	4	84
RNA 2203.2RS	18	168	RNA 4926	4	84
RNA 2204.2RS	18	168	RNA 4928	4	86
RNA 2205.2RS	18	168	RNA 69/22	4	78
RNA 2206.2RS	18	168	RNA 69/28	4	78
RNA 2207.2RS	18	168	RNA 69/32	4	80
RNA 2208.2RS	18	168	RNA 6901	4	74
RNA 2209.2RS	18	168	RNA 6902	4	76
RNA 2210.2RS	18	168	RNA 6903	4	76
RNA 4822	4	84	RNA 6904	4	76
RNA 4824	4	84	RNA 6905	4	78
RNA 4826	4	84	RNA 6906	4	78
RNA 4828	4	86	RNA 6907	4	80
RNA 4830	4	86	RNA 6908	4	80
RNA 4832	4	86	RNA 6909	4	80
RNA 4834	4	86	RNA 6910	4	82
RNA 4836	4	86	RNA 6911	4	82
RNA 4838	4	86	RNA 6912	4	82
RNA 4840	4	86	RNA 6913	4	82
RNA 4844	4	86	RNA 6914	4	82
RNA 4848	4	86	RNA 6915	4	84
RNA 4852	4	86	RNA 6916	4	84
RNA 4856	4	86	RNA 6917	4	84
RNA 4860	4	86	RNA 6918	4	84
RNA 4864	4	86	RNA 6919	4	84
RNA 4868	4	86	RNAO 5×10×8 TN	6	100
RNA 4872	4	86	RNAO 6×13×8 TN	6	100
RNA 4876	4	86	RNAO 7×14×8 TN	6	100
RNA 49/22	4	78	RNAO 8×15×10 TN	6	100
RNA 49/28	4	78	RNAO 10×17×10 TN	6	100
RNA 49/32	4	80	RNAO 12×22×12 TN	6	100
RNA 4900	4	74	RNAO 15×23×13	6	100
RNA 4900 RS	4	74	RNAO 16×24×13	6	100
RNA 4900.2RS	4	74	RNAO 16×28×12	6	100
RNA 4901	4	74	RNAO 17×25×13	6	100
RNA 4901 RS	4	74	RNAO 18×30×24	6	100
RNA 4901.2RS	4	74	RNAO 20×28×13	6	100
RNA 4902	4	76	RNAO 20×28×26	6	100
RNA 4902 RS	4	76	RNAO 20×32×12	6	100
RNA 4902.2RS	4	76	RNAO 22×30×13	6	100
RNA 4903	4	76	RNAO 22×35×16	6	100
RNA 4903 RS	4	76	RNAO 25×35×17	6	100
RNA 4903.2RS	4	76	RNAO 25×35×26	6	100
RNA 4904	4	76	RNAO 25×37×16	6	100
RNA 4904 RS	4	76	RNAO 30×40×17	6	100
RNA 4904.2RS	4	76	RNAO 30×42×16	6	100
RNA 4905	4	78	RNAO 30×42×32	6	100
RNA 4905 RS	4	78	RNAO 35×45×13	6	102
RNA 4905.2RS	4	78	RNAO 35×45×17	6	102

Designation	Code	Page	Designation	Code	Page
RNAO 35×45×26	6	102	SD 38×48×4	22	217
RNAO 35×47×16	6	102	SD 40×47×4	22	217
RNAO 35×47×18	6	102	SD 40×50×4	22	217
RNAO 35×47×32	6	102	SD 40×52×5	22	217
RNAO 40×50×17	6	102	SD 42×52×4	22	217
RNAO 40×50×34	6	102	SD 45×52×4	22	217
RNAO 40×55×20	6	102	SD 45×55×4	22	217
RNAO 40×55×40	6	102	SD 50×58×4	22	217
RNAO 45×55×17	6	102	SD 50×62×5	22	217
RNAO 45×62×40	6	102	STO 5 TN	18	170
RNAO 50×62×20	6	102	STO 6 TN	18	170
RNAO 50×65×20	6	102	STO 8 TN	18	170
RNAO 50×65×40	6	102	STO 10	18	170
RNAO 55×68×20	6	102	STO 12	18	170
RNAO 60×78×20	6	102	STO 15	18	170
RNAO 60×78×40	6	102	STO 17	18	170
RNAO 65×85×30	6	102	STO 20	18	170
RNAO 70×90×30	6	102	STO 25	18	170
RNAO 80×100×30	6	102	STO 30	18	170
RNAO 90×105×26	6	102	STO 35	18	170
RNAO 90×110×30	6	102	STO 40	18	170
RNAO 100×120×30	6	102	STO 45	18	170
RPNA 15/28	8	112	STO 50	18	170
RPNA 18/32	8	112	WS 81102	13	125
RPNA 20/35	8	112	WS 81103	13	125
RPNA 25/42	8	112	WS 81104	13	125
RPNA 28/44	8	112	WS 81105	13	125
RPNA 30/47	8	112	WS 81106	13	125
RPNA 35/52	8	112	WS 81107	13	125
RPNA 40/55	8	112	WS 81108	13	125
RPNA 45/62	8	112	WS 81109	13	125
RSTO 5 TN	18	168	WS 81110	13	125
RSTO 6 TN	18	168	WS 81111	13	125
RSTO 8 TN	18	168	WS 81112	13	125
RSTO 10	18	168	WS 81113	13	125
RSTO 12	18	168	WS 81114	13	125
RSTO 15	18	168	WS 81115	13	125
RSTO 17	18	168	WS 81116	13	125
RSTO 20	18	168	WS 81117	13	127
RSTO 25	18	168	WS 81118	13	127
RSTO 30	18	168	WS 81120	13	127
RSTO 35	18	168	WS 81122	13	127
RSTO 40	18	168	WS 81124	13	127
RSTO 45	18	168	WS 81126	13	127
RSTO 50	18	168	WS 81128	13	127
SD 8×15×3	22	216	WS 81130	13	127
SD 10×17×3	22	216	WS 81132	13	127
SD 12×18×3	22	216			
SD 12×19×3	22	216			
SD 14×20×3	22	216			
SD 14×22×3	22	216			
SD 15×21×3	22	216			
SD 15×23×3	22	216			
SD 16×22×3	22	216			
SD 16×24×3	22	216			
SD 17×23×3	22	216			
SD 17×25×3	22	216			
SD 18×24×3	22	216			
SD 18×26×4	22	216			
SD 19×27×4	22	216			
SD 20×26×4	22	216			
SD 20×28×4	22	216			
SD 22×28×4	22	216			
SD 22×30×4	22	216			
SD 24×32×4	22	216			
SD 25×33×4	22	216			
SD 25×35×4	22	216			
SD 26×34×4	22	217			
SD 28×35×4	22	217			
SD 30×37×4	22	217			
SD 30×40×4	22	217			
SD 32×42×4	22	217			
SD 35×42×4	22	217			
SD 35×45×4	22	217			
SD 37×47×4	22	217			

SKF®

www.motralec.com
service-commercial@motralec.com

