

THERMOBILE®



Parts List IMA 61 111 150 AXIAAL.

41722800

41724800

41726800

THERMOBILE[®]

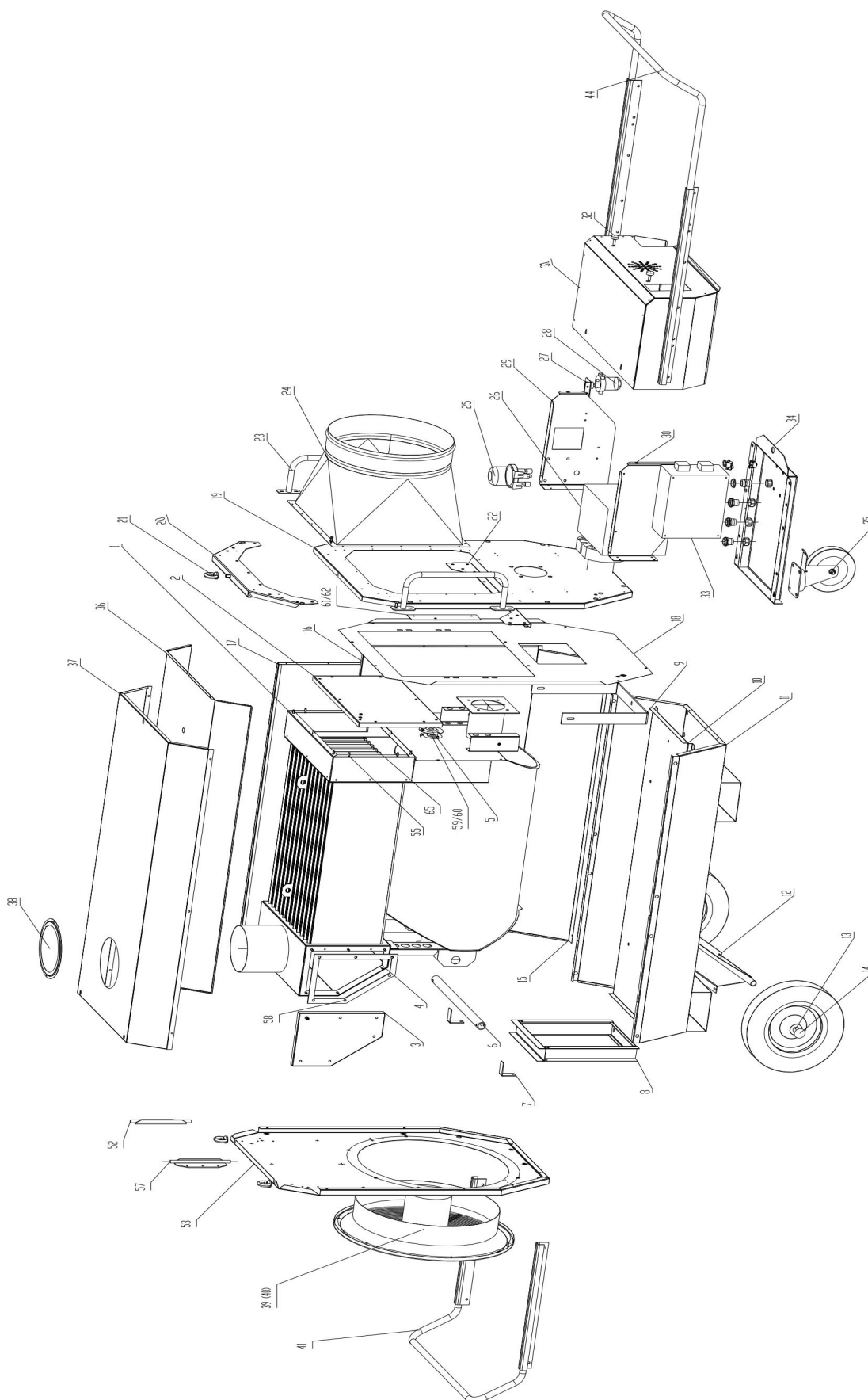

THERMOBILE®

Pos	Beschrijving Nederlands	Description English	Description Francais	Beschreibung Deutsch
1	branderkamer+WW	burnerchamber+heatexchanger	chambre de com.+ échangeur	Brennerkammer WärmeTau.
2	deksel WW voor	cover heat exchanger front	couvercle échangeur inférieur	Deckel vorne
3	deksel WW zijkant	cover heat exchanger back	couvercle échangeur jonction	Deckel seite
4	pakking voor posnr.3	gasket pos.number 3	join no. 3	Abdichtung nu. 3
5	kijkglashouder	window frame	support fenêtre	Rahmen von Schauglass
6	branderkamerophanging	burnerchamber support	chambre de combustion anneau	Brennerkammer Stütze
7	beugel	support	anneau	Bügel
8	steun branderkamer	support burnerchamber	anneau chambre de combustion	Brennerkammer Stütze
9	stelbeugel branderk.	adjst. bracketburnerchamber	support de réglage ch. de com.	Stellbügel
10	grondplaat	ground plate	tôle inférieure	Aufbaublech unten
11	bodembak	bottom	fond	Bodenblech
12	wielas	axle	axe	Achse
13	wiel	wheel	roue	Rad
14	starlock	starlock	capot	Radkappe
15	stralingsplaat L/R	radiation plate l+r	plaque radiante laterál g/d	Stralungsblech L+R
16	str.plaat zijpan. L+R	radiation plate l+r	plaque radiante laterál g/d	Stralungsblech L+R
17	zijpanelen L&R	side panel l+r	panneaux latéral g/d	Seitenwand L+R
18	stralingsplaat uitblaas	radiation plate front	plaque radiante sortie d'air	Stralungsblech Vornseite
19	uitblaaspaneel	front panel	sortie d'air	Ausblaßblech
20	verst.plaat boven	lifting profile	profilé de renforcement en haut	Verstärkungsprofil oben
21	oogmoer M12	lifting lug	anneau de suspension	Hebeöse
22	verst.plaat onder	reinforcement profile	profilé de renforcement en bas	Verstärkungsprofil unter
23	duwbeugel	conveyor handle	barre à pousser	Fahrbügel
24	uitblaasconus	outlet panel	cone de soufflage	Ausblaßconus
25	tigerloop	tigerloop	tigerloop	Tigerloop
26	brander slw	burner slw	brûleur slw	Brenner slw
27	filterbeugel	bracket oil filter	support filtre	Montagestütze Ölfilter
28	oliefilter	oil filter	filtre	Ölfilter
29	regenkap steun oliefilter	bracket oil filter	support protection filtre	Stütze Ölfilter
30	regenkap steun schakelkast	bracket switch box	support protection boîtier	Stütze schaltschrank
31a	regenkap zijpl. Links	raincover plate left	plaque de jonction gauche	Regenschütz Platte Links
31b	regenkap zijpl.rechts	raincover plate right	plaque de jonction droite	Regenschütz Platte Rechts
31c	regenkap	rain cover	protection de pluie	Regenschütz
32	kartelbout	bolt	boulon	Bolzen
33	schakelkast gemont.	switch box complete	boîtier électrique complet	Schaltkasten komplett
34	olieopvangbak	mounting plate swivel castor	plaque de fixation roues	Schwenkradblech
35	zwenkwiel	swivel castor	roue roulette	Schwenkrad
36	stralingsplaat deksel	radiation plate cover	plaque radiante supérieure	Stralungsblech Deckel
37	deksel	cover	couvercle	Deckel
38	schoorsteenring	chimney ring	collier pour cheminée	Schornsteinring
39	motor	motor	moteur	Motor
40	aanzuigpaneel	back panel radial	panneau radial	Ansaugpanel
41	stootbeugel	bumper	boufflet	Stoßbügel
42				
43				
44	stootbeugel	bumper	boufflet	Stoßbügel
45				

THERMOBILE®

Pos	Nederlands	English	Français	Deutsch
46				
47				
48				
49				
50				
51				
52	hoeklijn gel.links	angle plate left	piece d'angle gauche	Winkelstütze Links
53	aanzuigpaneel	back panel axial	panneau axial	Ansaugpanel
53a	str.plaat aanz.paneel	radiation plate back panel	plaque radiante pour 53	Kuhl platte für 53
54				
55	pakking voor posnr.2	gasket pos.number 2	join no. 2	Abdichtung nu. 2
56				
57	hoeklijn gel.rechts	angle plate right	piece d'angle droite	Winkelstütze Rechts
58	pakking	gasket	join	Abdichtung
59	pakking 1kijkglas	gasket 1	join no. 1	Abdichtung 1
60	pakking 2kijkglas	gasket 1	join no. 2	Abdichtung 2
60a	kijkglas	Inspection glass	fenêtre d'inspection	Inspektionsfenster
61				
62				
63				
64				
65	rookgasremmer	smoke gas resistance	résistance côté	Leitblech Rauchgass
Pos.	IMA 61 AX	IMA 111 AX	IMA 150 AX	
1	41.722.325	41.724.755	41.726.755	
2	41.722.307	41.724.659/01	41.726.021	
3	41.722.282	41.729.948	41.729.948	
4	41.722.309	41.726.125	41.726.125	
5	41.729.914	41.729.914	41.729.914	
6	41.722.288	41.724.521	41.726.106	
7	41.722.292/01	41.728.292/01	41.728.292/01	
8	41.722.289_7964/01	41.724.543_7964	41.726.028_7964	
9	41.722.301_7964	41.726.027_7964/01	41.726.027_7964/01	
10	41.722.042_05	41.724.042/07	41.726.084/01	
11	41.722.043_7964/05	41.724.668_7964	41.726.097_7964	
12	41.722.084_7964/05	41.724.080_7964/05	41.726.080_7964/03	
13	41.815.065	41.815.065	41.815.065	
14	41.524.194	41.524.194	41.524.194	
15	41.722.054	41.724.054/01	41.726.086	
16	41.722.057/03	41.724.057/08	41.726.088	
17	41.722.049_UV rood	41.724.168_UV rood/03	41.726.087_UV rood	
18	41.722.133/01	41.724.403/04	41.726.107/01	
19	41.722.132_7964	41.724.402_7964/03	41.726.091_7964/01	
20	41.722.280	41.724.280	41.726.093/01	
21	40.501.909	40.501.909	40.501.909	
22	41.722.089	41.724.089/01	41.726.092	
23	41.722.071_7964	41.724.071_7964	41.724.071_7964	

THERMOBILE®

Pos.	IMA 61 AX	IMA 111 AX	IMA 150 AX	
24	41.722.223_7964	41.724.223_7964	41.726.100_7964	
25	41.522.127	41.522.127	41.522.127	
26	41.522.050	41.524.130	41.726.150	
27	99.084.130_7964/04	99.084.130_7964/04	99.084.130_7964/04	
28	41.520.027	41.520.027	41.520.027	
29	41.722.135_7964	41.728.413_7964/05	41.728.413_7964/05	
30	41.722.134_7964	41.728.412_7964/03	41.728.412_7964/03	
31a	41.722.128_7964	41.724.422_7964	41.726.114_7964	
31b	41.722.129_7964	41.724.423_7964	41.726.115_7964	
31c	41.722.127_7964	41.724.411_7964/03	41.726.113_7964/01	
32	41.900.821	41.900.821	41.900.821	
33	41.722.316	41.722.316	41.722.316	
34	41.722.087_7964/03	41.724.087_7964/06	41.726.079_7964/03	
35	41.724.083	41.728.665	41.724.083	
36	41.722.295	41.724.653/01	41.726.085	
37	41.722.294_UV rood	41.724.652_UV rood/02	41.726.089_UV rood	
38	99.084.017_7964/01	41.728.297_7964	41.728.297_7964	
39	41.722.805	41.724.805	41.726.805	
40	41.722.806_7964	41.724.803_7964	41.726.803_7964	
41	41.722.807_7964	41.724.163_7964	41.726.809_7964	
42			41.728.099 (cond. 30mF)	
43				
44	41.722.160_7964/04	41.724.160_7964/03	41.726.112_7964	
45				
46				
47				
48				
49				
50				
51				
52	41.722.207	41.722.207	41.722.207	
53	41.722.803_7964	41.724.803_7964/02	41.726.803_7964	
53a	41.722.804	41.724.804/01	41.726.804	
54				
55	00.003.629	00.003.629	00.003.629	
56				
57	41.722.207	41.722.207	41.722.207	
58	41.726.125	41.726.125	41.726.125	
59	41.726.129	41.726.129	41.726.129	
60	41.726.130	41.726.130	41.726.130	
60a	41.900.775	41.900.775	41.900.775	
61				
62				
63				
64				
65	41.722.308/02	41.724.547/02	41.726.037/02	

THERMOBILE®

POS.	Olie aanvoer	Oil supply	Tigerloop		
1a	trafo(optie)	Transformer	transformateur	Transformator	41.728.185
1b	trafo set	Transformer kit			41.728.190
2	flowcontrol	flowcontrol	flowcontrol	Flowcontrol	41.522.127
3	beugel oliefilter	bracket oil filter	support filtre	Montagestütze Ölfilter	99.084.130_7964/04
4	slangpilaar 3/8'	hose socket	adapteur de tuyau	Schlauchansluß	41.520.025
5	oliefilter	oil filter	filtre	Ölfiter	41.520.027

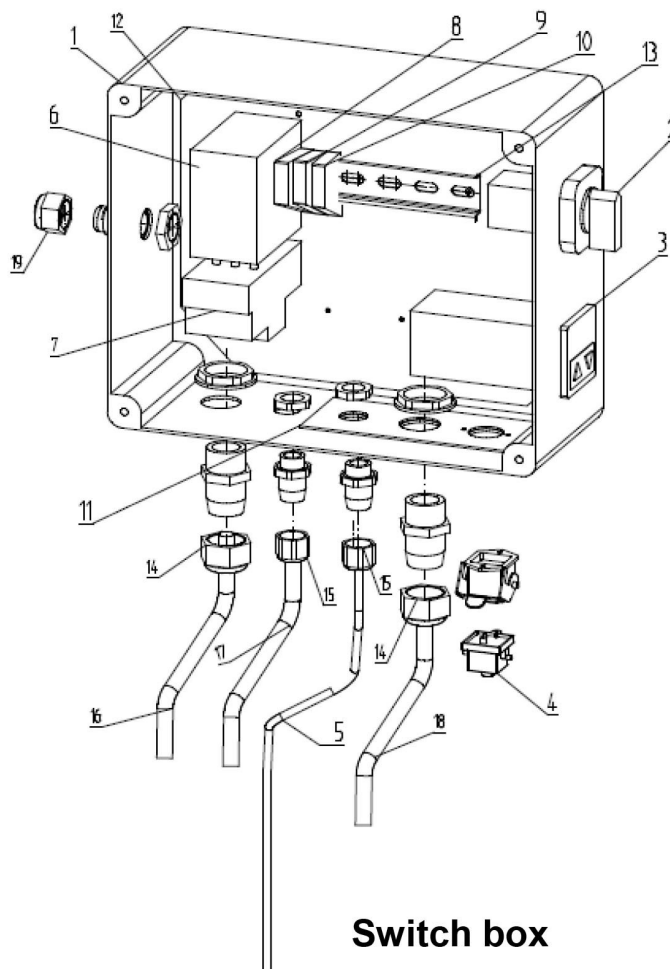
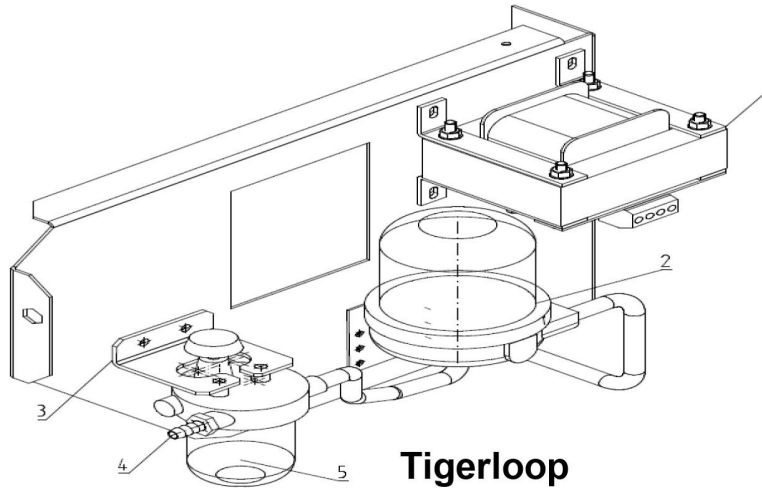

THERMOBILE®

	SWITCH BOX	SWITCH BOX	SWITCH BOX	SWITCH BOX
Pos.	NEDERLANDS	ENGLISCH	FRANCAIS	DEUTSCH
1	schakelkast geboord	switch box with holes	boîtier électrique	Schaltschrank montagebereit
2	schakelaar santon	switch santon	interrupteur santon	Schalter Santon
3	temp. Regelaar	temperature regulator	température régulateur	Temperatur Controller
4	stekerhuis	thermostat connection	prise thermostat	Thermostatansluß
	stekkerinzet	thermostat connection	prise thermostat	Thermostatansluß
	afdekkapje	bridge circuit plug thermostat	fiche court circuit	Brückenstecker
5	temperatuur sensor	temperature censor	température capteur	Temperatur Sensor
6	magneetschakelaar	magnetic switch	interrupteur magnétique	Magnetschalter
7	thermisch relais	thermal relay	protection thermique	Thermische Schutz
8	Relais omron	Relay omron	Relais omron	Schutz omron
9	Relais houder	Relay holder	Relais détenteur	Schutz behalter
10				
11	verstevinging plaat	plate	collier de fixation	Verstärkungsprofil
12	montage plaat	mounting plate	base du sessous de puvot	Montageplatte
13	DIN rail	rail	rail	Schiene
14	wartel M25x1,5	cable gland M25	Écrou	Kabelverschraubung
	wartelmoer M25x1,5	screw cap	Écrou de raccord	Mutter
15	wartel M16x1,5	cable gland M16	Écrou	Kabelverschraubung
	wartelmoer M16x1,5	screw cap	Écrou de raccord	Mutter
16	motorkabel	motor cable	moteur cablé	Motorkabel
17	branderkabel	burner cable	cablé bruleur	Brenner Kabel
18				
19	wartel M20x1,5	cable gland M20	Écrou	Kabelverschraubung
	wartelmoer M20x1,5	screw cap	Écrou de raccord	Mutter
pos	IMA 61 AX	IMA 111 AX	IMA 150 AX	
1	41.722.293/02	41.722.293/02	41.722.293/02	
2	41.728.424	41.728.424	41.728.424	
3	41.729.861	41.729.861	41.729.861	
4	40.202.092	40.202.092	40.202.092	
	40.202.091	40.202.091	40.202.091	
	40.226.030	40.226.030	40.226.030	
5	41.729.852	41.729.852	41.729.852	
6				
7				
8	41.740.328	41.740.328	41.740.328	
9	41.740.330	41.740.330	41.740.330	
10				
11	41.724.511	41.724.511	41.724.511	
12	41.722.264/03	41.722.264/02	41.722.264/02	
13	41.722.314	41.722.314	41.722.314	
14	40.503.022	40.503.022	40.503.022	
	40.503.023	40.503.023	40.503.023	
15	40.503.016	40.503.016	40.503.016	
	40.503.021	40.503.021	40.503.021	
16	41.722.802	41.724.802	41.726.802	
17	41.722.665	41.722.662	41.722.662	
18	40.202.088	40.202.088	40.202.088	
19	40.503.022	40.503.022	40.503.022	
	40.503.023	40.503.023	40.503.023	
	41.722.018	41.722.018	41.722.018	Fuse holder
	41.218.003	41.218.003	41.218.003	Fuse 10A

THERMOBILE®

SLV 22/44/55 Brander/Burner/Bruleur/Brenner

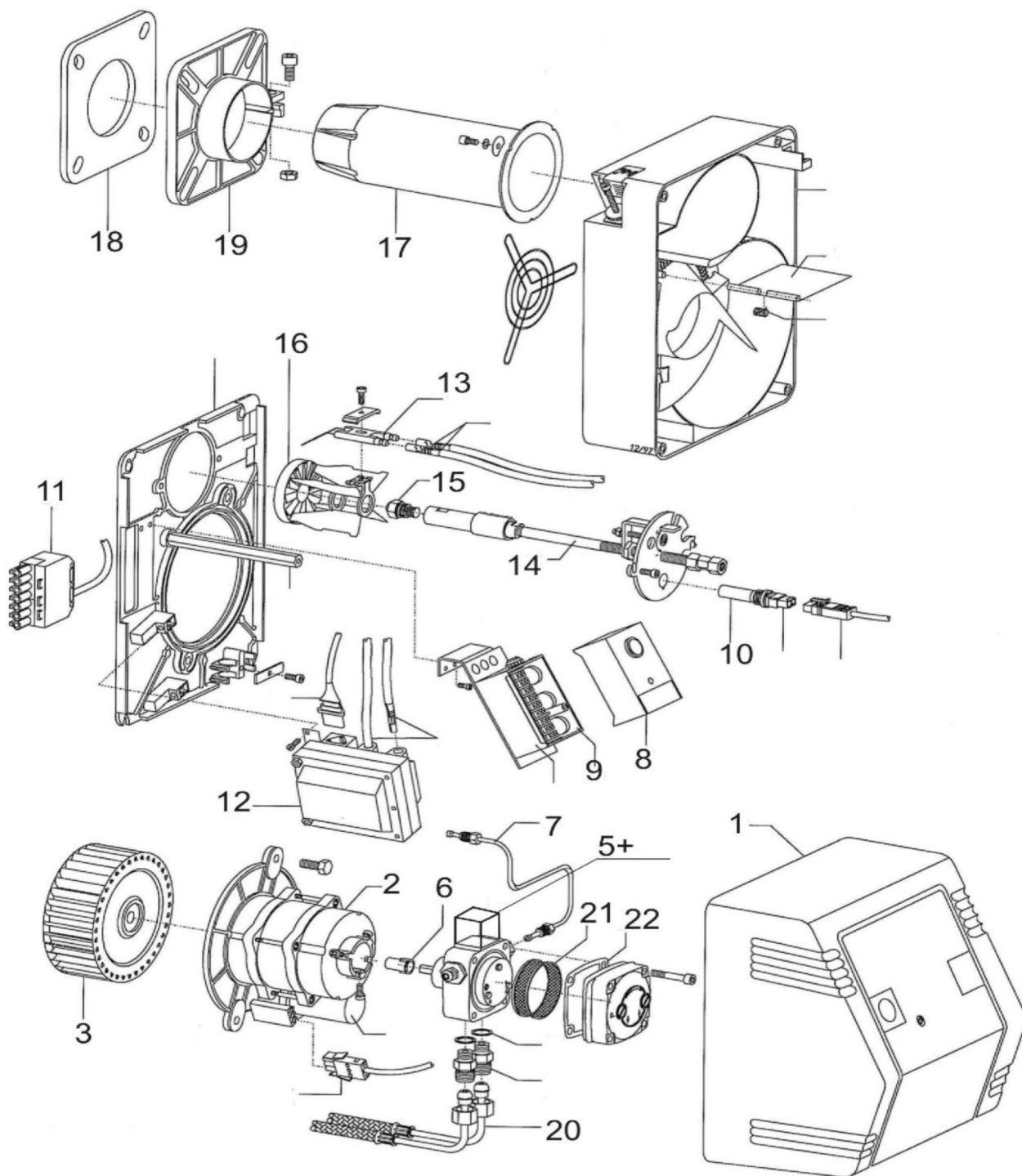

THERMOBILE®

SLV 22/44/55 Brander/Burner/Bruleur/Brenner

	Nederlands	English	Francais	Deutsch
1	Branderkap	Burner cover	Capot du brûleur	Brennerschutzhause
2	Brandermotor	Burner motor	Moteur du brûleur	Brennermotor
3	Ventilator	Fan	Ventilateur	Lüfterrad
4	Brandstofpomp	Fuelpump	Pompe à fuel	Pumpe
5	Magneetventiel	Magnetic valve	Vanne électromagnétique	Magnetventil
6	Pompkoppeling	Pump coupling	Accouplement de la pompe	Pumpenkupplung
7	Drukleiding	Pressure pipe	Tubepompe	Druckleitung
8	Branderautomaat	Burner relay	Relais du brûleur	Steuerrelais
9	Konsole branderautomaat	Support burner relay	Console relais du brûleur	Relaissockel
10	Fotocel MZ 770 + adapter	Photocell MZ 770 +adapter	Cellule photo-electr. MZ 770 +adapteur	Fotozelle MZ 770 +adapter
11	Kontrastekker	Coupling socket	Fiche de raccordement	Stecker
12	Ontstekingstrafo	Ignition transformer	Transformateur d'allumage	Zündtrafo
13	Ontstekingselektrode	Ignition electrode	Électrode d'allumage	Zündelektrode
14	Verstuihverhouder	Nozzle holder	Support de gicleur	Düsenstock
15	Verstuiver	Nozzle	Gicleur	Öldüse
16	Stuwplaat	Swivel disc	Volet de gicleur	Turbolator
17	Branderpijp	Burner pipe	Guelard	Flammrohr
18	Flenspakking	Flange packing	Joint de bride	Klingerit Flansch
19	Branderflens	Burner flange	Bride du brûleur	Brennerflansch
20a	Brandstofslang	Fuel pump hose	Tuyau de fuel	Ölleitung red
20b	Brandstofslang	Fuel pump hose	Tuyau de fuel	Ölleitung green
21	Oliepompfilter	Fuel pump filter	Filtre de pompe à fuel	Pumpenfilter
22	Pomppakking	Pumpgasket		
-*	Urenteller	Hour counter	Compteur horaire	Stundenzähler
-*	Beugel urenteller	Counter bracket	Anneau de compteur	Zählerbügel
-*	Kabel urenteller	Counter cable	Câble de compteur	Zählerkabel
	SLW 22	SLW 44	SLW 55	
1	41.520.067	41.524.131	41.524.131	
2	41.520.068	41.524.132	41.524.132	
3	41.520.069	41.524.133	41.524.133	
4	41.520.070/01	41.520.070/01	41.520.070/01	
5	41.000.388	41.000.388	41.000.388	
6	40.223.041	40.223.041	40.223.041	
7	41.520.071	41.524.137	41.524.137	
8	41.524.112	41.524.112	41.524.112	
9	41.524.113	41.524.113	41.524.113	
10	41.000.376 + 41.000.379	41.000.376+ 41.000.379	41.000.376+ 41.000.379	
11	41.520.045	41.520.045	41.520.045	
12	41.524.139	41.524.139	41.524.139	
13	41.524.140	41.524.240	41.524.240	
14	41.527.207	41.728.119	41.728.119	
15	40.504.709	41.524.042/ima-111 40.238.021/ima-150	41.728.101	
16	41.522.051	41.524.143	41.524.143	
17	41.520.074	41.524.144	41.524.144	
18	41.520.075	41.524.145	41.524.145	
19	41.520.076	41.524.146	41.524.146	
20a	41.728.315	41.728.315	41.728.315	
20b	41.728.316	41.728.316	41.728.316	
21	41.000.387	41.000.387	41.000.387	
22	40.202.121	40.202.121	40.202.121	
-*	41.729.107	41.729.107	41.729.107	
-*	41.728.208	41.728.208	41.728.208	
-*	41.728.209	41.728.209	41.728.209	

THERMOBILE®

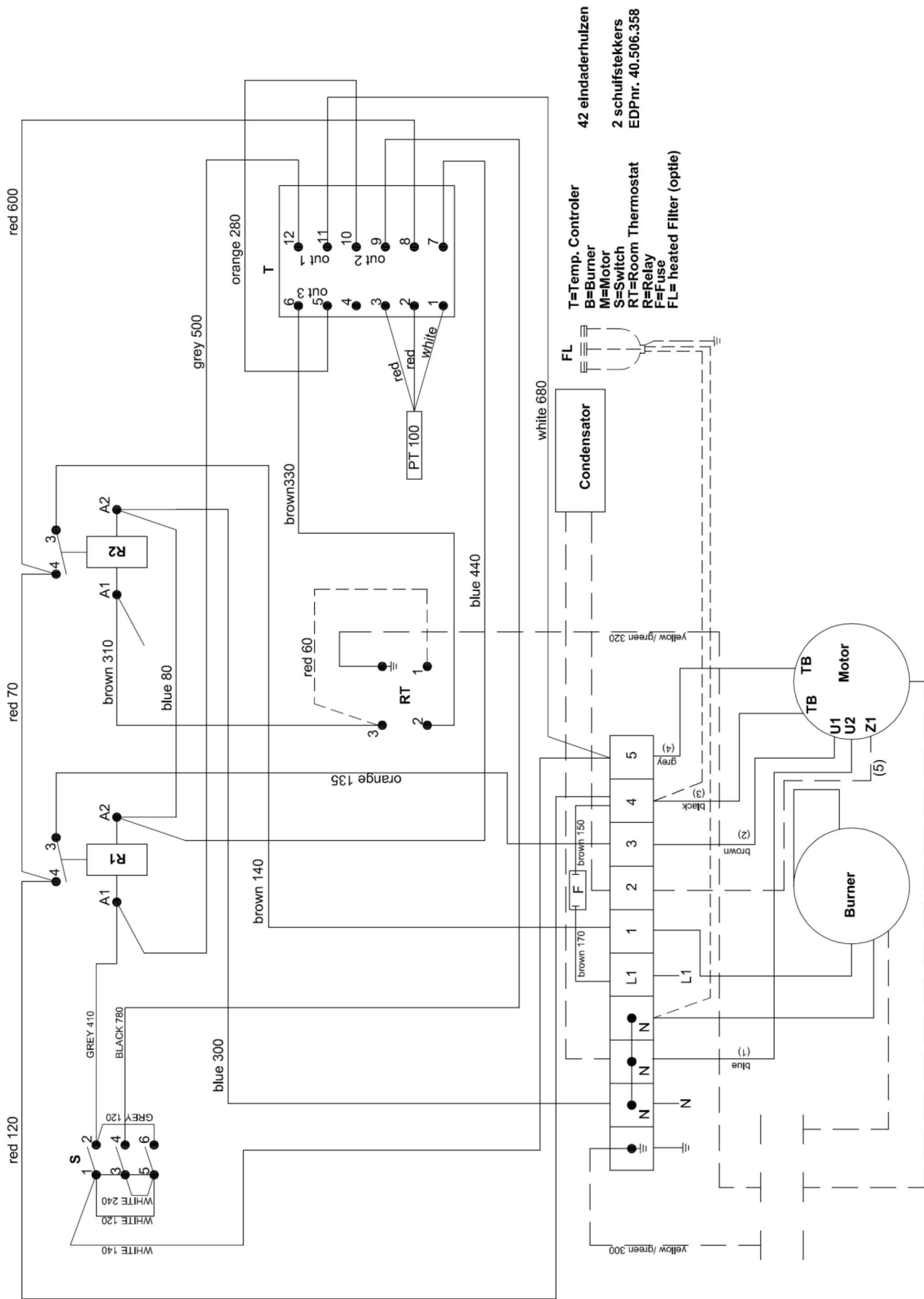

41724801
IMA 61 111 150 AXIAAL

EG-VERKLARING VAN OVEREENSTEMMING

THERMOBILE INDUSTRIES B.V.
Gevestigd aan de Konijnenberg 80 , 4825 BD BREDA,
Verklaren geheel onder eigen verantwoordelijkheid dat het producten,

**OLIE GESTOOKTE LUCHTVERHITTER
IMA-61/IMA-111/IMA-150/IMA-200**

Voldoen aan de volgende EG – richtlijnen.
Machine-richtlijnen: 2006/42/EG
Laagspanningsrichtlijn: 2006/95/EG
EMC-richtlijn: 2004/108/EG

Nederland, Breda, 23-3-2011
Maurice de Vlieger
Sales & Marketing
Director

EG-KONFORMITÄTSERKLÄRUNG

THERMOBILE INDUSTRIES B.V.
Konijnenberg 80 , 4825 BD BREDA,
Erklären hiermit eigenverantwortlich , daß die Produkte,

**HEIZÖL GEHEIZTE LUFTERHITZER
IMA-61/IMA-111/IMA-150/IMA-200**

Wo auf sich diese Erklärung bezieht, hergestellt ist gemäß der
Bestimmungen der Richtlinien für:
Maschinen-Richtlinien: 2006/42/EG
Niederspannungsrichtlinie: 2006/95/EG
EMV-Richtlinie: 2004/108/EG

Die Niederlande, Breda, 23-3-2011
Maurice de Vlieger
Sales & Marketing
Director

CE-DECLARATION OF CONFORMANCE

THERMOBILE INDUSTRIES B.V.
Konijnenberg 80 , 4825 BD BREDA,
Declares fully under own responsibility that the products:

**OIL FIRED INDIRECT HEATER
IMA-61/IMA-111/IMA-150/IMA- 200**

To which this statement has reference to, are in conformity
with the following regulations:

Machine-regulations: 2006/42/EC
Low Voltage Directive: 2006/95/EC
EMC-regulation: 2004/108/EC

The Netherlands, Breda, 23-3-2011
Maurice de Vlieger
Sales & Marketing
Director

DÉCLARATION DE CONFORMITÉ CE

THERMOBILE INDUSTRIES B.V.
Konijnenberg 80 , 4825 BD BREDA, LES PAYS-BAS,
Déclare sous sa seule responsabilité que les produits:

**GÉNÉRATEURS AU FIOUL À ÉCHANGEUR
IMA-61/IMA-111/IMA-150/IMA- 200**

Auxquels se réfère cette déclaration, sont conformes aux
normes suivantes:
Directive sur les machines:2006/42/CE
Directive sur la basse tension: 2006/95/CE
Directive sur la compatibilité électromagnétique: 2004/108/CE

Les Pays-Bas, Breda, 23-3-2011
Maurice de Vlieger
Sales & Marketing
Director

DECLARACIÓN CE DE CONFORMIDAD

THERMOBILE INDUSTRIES B.V.,
Konijnenberg 80, NL-4825 BD BREDA,
asume plena responsabilidad al declarar que los productos:

**CALENTADOR DE AIRE CALIENTE DE
COMBUSTIÓN INDIRECTA IMA-61/IMA-111/IMA-150/IMA-200**

cumple con las siguientes directivas CE:
Directiva de máquinas: 2006/42/CE
Directiva de baja tensión: 2006/95/CE
Directiva EMC: 2004/108/CE

Holanda, Breda, 09-05-2011
Maurice de Vlieger
Sales & Marketing
Director

ЕС-Декларация соответствия

THERMOBILE INDUSTRIES B.V.,
Konijnenberg 80, NL-4825 BD BREDA с
полной ответственностью заявляет, что
изделия:

**ЖИДКОТОПЛИВНЫЕ НАГРЕВАТЕЛИ
НЕПРЯМОГО ТИПА IMA-61/IMA-111/IMA-150/IMA- 200**

к которым относится данное заявление,
соответствуют следующим директивам ЕС:

Нормы машинного оборудования 2006/42/ЕС
Инструкция по работе с низким напряжением 2006/95/ЕС

Нидерланды, Бреда, 09-05-2011
Maurice de Vlieger
Sales & Marketing
Director
