

AQTL/AQTH/AQTC/AQTR



English

Français

Deutsch

Italiano

Español



269
↓
478 kW



273
↓
670 kW



Air-Cooled Water Chillers and Heat Pumps

Refroidisseurs d'Eau et Pompe à Chaleur Refroidis à l'Air

Luftgekühlte Flüssigkeitskühler und Wärmepumpen

Refrigeratori d'Acqua e Pompe di Calore Raffreddati ad Aria

Enfriadores de Agua y Bomba de Calor Condensadas con Aire

IOM AQT.410-N.2 GB

Part number / Codice / Code / Code / Código : 035B09056-000A

Supersedes / Annulla e sostituisce / Annule et remplace / Annulliert und ersetzt /

Anula y sustituye: **035B09056-000**

"Notified Body / Organismo Notificato / Organisme Notifié / Benannte
Zertifizierungsstelle / Organismo Notificado **No. 1115 PASCAL**"



1 FOREWORD		5 START-UP	
1.1 Introduction	3	5.1 Preliminary check	21
1.2 Warranty	3	5.2 Start-up	21
1.3 Emergency stop/Normal stop	3	5.3 Checking the operation	22
1.4 An introduction to this manual	3	5.4 Delivery to the customer	22
2 SAFETY		6 CONTROL	
2.1 Foreword	4	6.1 Control of AQT	
2.2 Definitions	4	The "CHILLER CONTROL" system	23
2.3 Access to the unit	5	6.2 Display	24
2.4 General precautions	5	6.3 Key board	24
2.5 Precautions against residual risks	5	6.4 Protection and safety equipment	27
2.6 Precautions during maintenance operations	6	6.5 HPF version configuration	28
2.7 Safety labels	7	7 GENERAL DESCRIPTION	
2.8 Safety regulations	9	7.1 Introduction	29
3 TRANSPORT, LIFTING AND POSITIONING		7.2 General specifications	29
3.1 Inspection	12	7.3 Compressors	29
3.2 Lifting	12	7.4 Refrigeration circuits	29
3.3 Anchoring	13	7.5 Water heat exchanger	29
3.4 Storage	13	7.6 Air heat exchanger	30
4 INSTALLATION		7.7 Fans	30
4.1 Positioning of the unit	14	7.8 Electric power supply and control system	32
4.2 Spring Isolator Installation	14	7.9 Accessories	32
4.3 External hydraulic circuit	15	8 TECHNICAL DATA	
4.4 Hydraulic connection	16	8.1 Pressure drop	33
4.5 Draining the Defrosting Waste Water (for heat pump unit only)	16	8.2 Technical data	34
4.6 Power supply	17	8.3 Unit Electrical data	44
4.7 Electrical connections	17	8.4 Hydraulic Features	46
4.8 Connecting plate-type evaporator temperature sensors	19	8.5 Position of shock absorbers and weight distribution on supports	49
4.9 Total heat recovery features	20	8.6 Overall dimensions	56
		8.7 Services spaces	68

9 MAINTENANCE

9.1	General requirements	69
9.2	Planned maintenance	69
9.3	Refrigerant charge	70
9.4	Compressor	70
9.5	Condenser	70
9.6	Fans	70
9.7	Dehydrating filter	71
9.8	Sight glass	71
9.9	Electronic expansion valve	71
9.10	Evaporator	71

10 TROUBLESHOOTING 72

11 SPARE PARTS

11.1	Spare parts list	74
11.2	Oil for compressors	74
11.3	Wiring diagram	74

12 DISMANTLING, DEMOLITION AND SCRAPPING

12.1	Generalities	75
------	--------------	----

Foreword

1 FOREWORD

1.1 Introduction

Airwell-Italia units, manufactured to state-of-the-art design and implementation standards, ensure top performance, reliability and fitness to any type of air-conditioning systems.

These units are designed for cooling water or glycolated water (and for water heating in heat pump models) and are unfit for any purposes other than those specified in this manual.

This manual includes all the information required for a proper installation of the units, as well as the relevant operating and maintenance instructions.

It is therefore recommended to read this manual carefully before installation or any operation on the machine. The chiller installation and maintenance must be carried out by skilled personnel only (where possible, by one of Airwell-Italia's Authorised Service Centers).

The manufacturer may not be held liable for any damage to people or property caused by improper installation, start-up and/or improper use of the unit and/or failure to implement the procedures and instructions included in this manual.

1.2 Warranty

These units are delivered complete, tested and ready for being operated. Any form of warranty will become null and void in the event that the appliance is modified without Airwell-Italia's preliminary written authorisation.

This warranty shall apply providing that the installation instructions have been complied with (either issued by Airwell-Italia, or deriving from the current practice), and the Form 1 ("Start-up") has been filled-in and mailed to Airwell-Italia (attn. After-Sales Service).

In order for this warranty to be valid, the following conditions shall be met:

- The machine must be operated only by skilled personnel from Airwell-Italia's Authorised After-Sales Service.
- Maintenance must be performed only by skilled personnel - from one of Airwell-Italia's Authorised After-Sales Centers.
- Use only original Airwell-Italia spare parts.
- Carry out all the planned maintenance provided for by this manual in a timely and proper way.

Failure to comply with any of these conditions will automatically void the warranty.

1.3 Emergency stop / Normal stop

The emergency stop of the unit can be enabled using the master switch on the control panel (move down the lever).

For a normal stop, press the relevant push-buttons.

To restart the appliance, follow the procedure detailed in this manual.

1.4 An introduction to the manual

For safety reasons, it is imperative to follow the instructions given in this manual. In case of any damage caused by non-compliance with these instructions, the warranty will immediately become null and void.

Conventions used throughout the manual:



The Danger sign recalls your attention to a certain procedure or practice which, if not followed, may result in serious damage to people and property.



The Warning sign precedes those procedures that, if not followed, may result in serious damage to the appliance.



The Notes contain important observations.



The Useful Tips provide valuable information that optimises the efficiency of the appliance.

This manual and its contents, as well as the documentation which accompanies the unit, are and remain the property of Airwell-Italia, which reserves any and all rights thereon. This manual may not be copied, in whole or in part, without Airwell-Italia's written authorization.

2 SAFETY

2.1 Foreword

These units must be installed in conformity with the provisions of Machinery Directive 98/37/EC, Low Voltage Directive 2006/95/EC, Pressure Vessels Directive 97/23/EC, Electromagnetic Interference Directive 89/336/EC, as well as with other regulations applicable in the country of installation. If these provisions are not complied with, the unit must not be operated.



The unit must be grounded, and no installation and/or maintenance operations may be carried out before deenergising the electrical panel of the unit.

Failure to respect the safety measures mentioned above may result in electrocution hazard and fire in the presence of any short-circuits.



Inside the heat exchangers, the compressors and the refrigeration lines, this unit contains liquid and gaseous refrigerant under pressure. The release of this refrigerant may be dangerous and cause injuries.



The units are not designed to be operated with natural refrigerants, such as hydrocarbons. Airwell-Italia may not be held liable for any problems deriving from the replacement of original refrigerant or the introduction of hydrocarbons.

Airwell-Italia units are designed and manufactured according to the requirements of European Standard PED 97/23/EC (pressure vessels).

- The used refrigerants are included in group II (non-hazardous fluids).
- The maximum working pressure values are mentioned on the unit's data plate.
- Suitable safety devices (pressure switches and safety valves) have been provided, to prevent any anomalous overpressure inside the plant.
- The vents of the safety valves are positioned and oriented in such a way as to reduce the risk of contact with the operator, in the event that the valve is operated. Anyway, the installer will convey the discharge of the valves far from the unit.
- Dedicated guards (removable panels with tools) and danger signs indicate the presence of hot pipes or components (high surface temperature).



The guards of the fans (only for units provided with air heat exchangers) must be always mounted and must never be removed before de-energising the appliance.



It is the User's responsibility to ensure that the unit is fit for the conditions of intended use and that both installation and maintenance are carried out by experienced personnel, capable of respecting all the recommendations provided by this manual. It is important that the unit is adequately supported, as detailed in this manual. Non-compliance with these recommendations may create hazardous situations for the personnel.



The unit must rest on a base which meets the characteristics specified in this manual; a base with inadequate characteristics is likely to become a source of serious injury to the personnel.



The unit has not been design to withstand loads and/or stress that may be transmitted by adjacent units, piping and/or structures. Each external load or stress transmitted to the unit may break or cause breakdowns in the unit's structure, as well as serious dangers to people. In these cases, any form of warranty will automatically become null and void.



The packaging material must not be disposed of in the surrounding environment or burnt.

2.2 Definitions

OWNER: means the legal representative of the company, body or individual who owns the plant where Airwell-Italia unit has been installed; he/she has the responsibility of making sure that all the safety regulations specified in this manual are complied with, along with the national laws in force.

INSTALLER: means the legal representative of the company who has been given by the owner the job of positioning and performing the hydraulic, electric and other connections of Airwell-Italia unit to the plant: he/she is responsible for handling and properly installing the appliance, as specified in this manual and according to the national regulations in force.

OPERATOR: means a person authorised by the owner to do on Airwell-Italia unit all the regulation and control operations expressly described in this manual, that must be strictly complied with, without exceeding the scope of the tasks entrusted to him.

ENGINEER: means a person authorised directly by Airwell-Italia or, in all EC countries, excluding Italy, under his full responsibility, by the distributor of Airwell-Italia product, to perform any routine and extraordinary maintenance operations, as well as any regulation, control, servicing operations and the replacement of pieces, as may be necessary during the life of the unit.

2.3 Access to the unit

The unit must be placed in an area which can be accessed also by OPERATORS and ENGINEERS; otherwise the unit must be surrounded by a fence at not less than 2 meters from the external surface of the machine.

OPERATORS and ENGINEERS must enter the fenced area only after wearing suitable clothing (safety shoes, gloves, helmet etc.). The INSTALLER personnel or any other visitor must always be accompanied by an OPERATOR.

For no reason shall any unauthorised personnel be left alone in contact with the unit.

2.4 General precautions

The OPERATOR must simply use the controls of the unit; he must not open any panel, other than the one providing access to the control module.

The INSTALLER must simply work on the connections between plant and machine; he must not open any panels of the machine and he must not enable any control.

When you approach or work on the unit, follow the precautions listed below:

- do not wear loose clothing or jewellery or any other accessory that may be caught in moving parts
- wear suitable personal protective equipment (gloves, goggles etc.) when you have to work in the presence of free flames (welding operations) or with compressed air
- if the unit is placed in a closed room, wear ear protection devices
- cut off connecting pipes, drain them in order to balance the pressure to the atmospheric value before disconnecting them, disassemble connections, filters, joints or other line items
- do not use your hands to check for any pressure drops

- use tools in a good state of repair; be sure to have understood the instructions before using them
- be sure to have removed all tools, electrical cables and any other objects before closing and starting the unit again

2.5 Precautions against residual risks

Prevention of residual risks caused by the control system

- be sure to have perfectly understood the operating instructions before carrying out any operation on the control panel
- when you have to work on the control panel, keep always the operating instructions within reach
- start the unit only after you have checked its perfect connection to the plant
- promptly inform the ENGINEER about any alarm involving the unit
- do not reset manual restoration alarms unless you have identified and removed their cause

Prevention of residual mechanical risks

- install the unit according to the instructions provided in this manual
- carry out all the periodical maintenance operations prescribed by this manual
- wear a protective helmet before accessing the interior of the unit
- before opening any panelling of the machine, make sure that it is secured to it by hinges
- do not touch air condensation coils without wearing protective gloves
- do not remove the guards from moving elements while the unit is running
- check the correct position of the moving elements' guards before restarting the unit

Prevention of residual electrical risks

- connect the unit to the mains according to the instructions provided in this manual
- periodically carry out all the maintenance operations specified by this manual
- disconnect the unit from the mains by the external disconnecting switch before opening the electrical board
- check the proper grounding of the unit before start-up
- check all the electrical connections, the connecting cables, and in particular the insulation; replace worn or damaged cables

- periodically check the board's internal wiring
- do not use cables having an inadequate section or flying connections, even for limited periods of time or in an emergency

Prevention of other residual risks

- make sure that the connections to the unit conform to the instructions provided in this manual and on the unit's panelling
- if you have to disassemble a piece, make sure that it has been properly mounted again before restarting the unit
- do not touch the delivery pipes from the compressor, the compressor and any other piping or component inside the machine before wearing protective gloves
- keep a fire extinguisher for electrical appliances near the machine
- on the units installed indoors, connect the safety valve of the refrigeration circuit to a piping network that can channel any overflowing refrigerant outside
- remove and leak of fluid inside and outside the unit
- collect the waste liquids and dry any oil spillage
- periodically clean the compressor compartment, to remove any fouling
- do not store flammable liquids near the unit
- do not disperse the refrigerant and the lubricating oil into the environment
- weld only empty pipes; do not approach flames or other sources of heat to refrigerant pipes
- do not bend/hit pipes containing fluids under pressure

2.6 Precautions during maintenance operations

Maintenance operations can be carried out by authorised technicians only.

Before performing any maintenance operations:

- disconnect the unit from the mains with the external disconnecting switch
- place a warning sign "do not turn on - maintenance in progress" on the external disconnecting switch
- make sure that on-off remote controls are inhibited
- wear suitable personal protective equipment (helmet, safety gloves, goggles and shoes etc.)

To carry out any measurements or checks which require the activation of the machine:

- work with the electrical board open only for the necessary time
- close the electrical board as soon as the measurement or check has been completed
- for outdoor units, do not carry out any operations in the presence of dangerous climatic conditions (rain, snow, mist etc.)

The following precautions must be always adopted:

- do not scatter the fluids of the refrigeration circuit in the surrounding environment
- when replacing an eprom or electronic cards, use always suitable devices (extractor, antistatic bracelet, etc.)
- to replace a compressor, the evaporator, the condensing coils or any other weighty element, make sure that the lifting equipment is consistent with the weight to be lifted
- in air units with independent compressor compartment, do not access the fan compartment unless you have disconnected the machine by the disconnecting switch on the board and you have placed a warning sign "do not turn on - maintenance in progress"
- contact Airwell-Italia for any modifications to the refrigeration, hydraulic or wiring diagram of the unit, as well as to its control logics
- contact Airwell-Italia if it is necessary to perform very difficult disassembly and assembly operations
- use only original spare parts purchased directly from Airwell-Italia or the official retailers of the companies on the recommended spare parts list
- contact Airwell-Italia if it is necessary to handle the unit one year after its positioning on site or if you wish to dismantle it.

2.7 Safety labels

The labels below will be affixed to each unit in the indicated point:



Identification of the refrigerant - External door

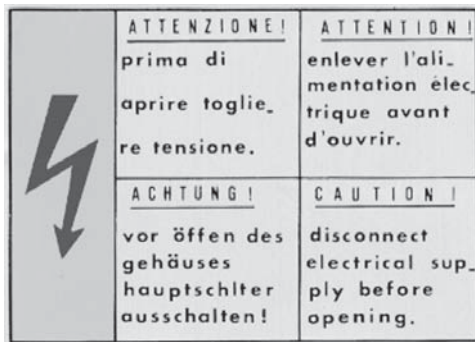

Electrical warning Adjacent to the master switch



Read the instruction - On the electrical board



On the compressor box

COD. PRODOTTO NEUTRO PRODUCT CODE	<input type="text"/>
MODELLO MODEL	<input type="text"/>
CE	<input type="text"/>
OdL	<input type="text"/>
MATRICOLA SERIAL NUMBER	<input type="text"/>
ANNO DI COSTRUZIONE	<input type="text"/>
CARICA REFR. REFRIGERANT CHARGE	CIRCUITO 1 2 3 4 Kg <input type="text"/> <input type="text"/> <input type="text"/> <input type="text"/>
ALTA PRESSIONE HIGH PRESSURE	(max) bar <input type="text"/>
BASSA PRESSIONE LOW PRESSURE	(max) bar <input type="text"/>
ALIM. POTENZA MAIN SUPPLY	V/PH/Hz <input type="text"/> <input type="text"/>
CORRENTE DI SPUNTO LRA	(max) A <input type="text"/>
CORRENTE A PIENO CARICO	(max) A <input type="text"/>
POTENZA ASSORBITA POWER INPUT	(max) Kw <input type="text"/>
PRESS. ESERC. ACQUA WATER OPERATION PRESSURE	(max) bar <input type="text"/>
MASSA MASS	(max) Kg <input type="text"/>
ITELCO-INDUSTRY S.r.l. Via XXV Aprile 29 20030 BARLASSINA MI (ITALIA) MADE IN ITALY	

Identification of the unit - Outside, on the right-hand front column



Gravity centre - Base



Grounding connection - On the electrical board, adjacent to the connection

ATTENZIONE

INSERIRE LE RESISTENZE DI RISCALDAMENTO OLIO ALMENO 12 ORE PRIMA DI OGNI AVVIAMENTO (SE PREVISTE)
PRIMA DELLA MESSA IN TENSIONE ASSICURARSI CHE LE VITI DEI CIRCUITI ELETTRICI SIANO SERRATE COMPLETAMENTE

WARNING

ENERGIZE THE CRANKCASE HEATER FOR AT LEAST 12 HOURS BEFORE EACH STARTING (IF FITTED)
BEFORE TIGHTENING-UP, TO TIGHTEN ALL TERMINAL SCREWS ESPECIALLY THOSE IN MAIN CIRCUIT

WARNUNG

OLSUMPFHEIZUNG (FALLS VORHANDEN) 12 STUNDEN VOR DEM START EINSCHALTEN VOR INBETRIEBNAHME ALLE SCHRAUBENVERBINDUNGEN NACHZIEHEN, BESONDERS DIE ELEKTRISCHEN ANSCHLÜSSE

ATTENTION

ALIMENTER ELECTRIQUEMENT LA RESISTANCE DE CARTER AU MOINS 12 HEURES AVANT CHAQUE DEMARRAGE (SI MONTE SUR LE PRODUIT)
AVANT DE DEMARRER LA MACHINE, VERIFIER LE SERRAGE DE TOUTES LES BORNES A VIS, SPECIALMENT DANS LE BOITIER ELECTRIQUE

ATENCIÓN

ATENCIÓN! ALIMENTAR ELÉCTRICAMENTE LA RESISTENCIA DE CARTER AL MENOS 12 HORAS ANTES DE CADA PUESTA EN MARCHA (SI ESTA EQUIPADA EN LA UNIDAD)
ANTES DE LA PUESTA EN MARCHA, COMPROBAR QUE LOS BORNES ESTÁN BIEN APRETADOS, ESPECIALMENTE EN EL CUADRO ELÉCTRICO

035B00057-000 MADE IN ITALY

**Start-up warning -
Outside the door of the electrical board**

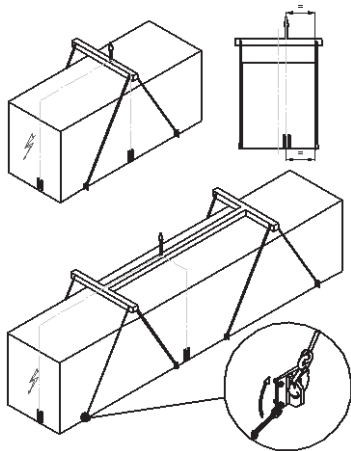

Instruction for the lifting

EIN - INLET
ENTRÉE - ENTRATA
AUS - OUTLET
SORTIE - USCITA
**Fitting identification -
Adjacent to fittings**

CERTIFICATO DI COLLAUDO PRODUZIONE ITELCO-CLIMA
ITELCO-CLIMA PRODUCTION TEST CERTIFICATE

UNITA' ARIA-ARIA/ARIA-ACQUA - SEMICENTRALI - CHILLER AIR/AIR AIR/WATER

PROGR. COLL. NUMBER CHECK	DESCRIZIONE DEI TEST DESCRIPTION OF QUALITY CHECK	TIMERO OPERAT. INSP. CODE
01	VERIFICA ASSEMBLAGGIO VERIFY ASSEMBLY COMPLETE	
02	VERIFICA VISIVA CABLAGGIO COLLEG. ELETTRICI E CONNESSIONE VERIFY WIRING CONNECTIONS	
03	VUOTO E CARICA REF. VACUUM AND CHARGE TEST	
04	VERIFICA CON CERCAFUGHE TENUTA CIRCUITO FRIGORIFERO REFRIGERANT LEAK TEST	
05	PROVE FUNZIONALI CON RILIEVI TEMPERATURA/PRESSIONI-RUMORE FUNCTION AND RUN TEST NOISE TEST	
06	VERIFICA INTERVENTI SICUREZZE PRESSIONE E TEMPERATURA CHECK OPERATION AND SAFETY DEVICES	
07	VERIFICA TENUTA CIRCUITO IDR. E FUNZIONAMENTO POMPA (SU PACK) HYDRAULIC CIRCUIT TEST (PUMP CHECK ONLY FOR PACK UNIT)	
08	VERIFICA MONTAGGIO ACCESSORI (SE PREVISTI) E DOCUMENTAZIONE CHECK ACCESSORIES-DOCUMENTATION	
09	CONTROLLO ESTETICO FINALE E PULIZIA INTERNA VISUAL CHECK FOR DIRT AND DAMAGE	

**Final Test Certificate -
Inside the external door**



ATTENZIONE! BORDI TAGLIANTI
VORSICHT! SCHARFE RÄNDER
CAUTION! SHARP EDGES
ATTENTION! BORDS COUPANTS
ATENCIÓN! PERFIL AFILADO

On the coil

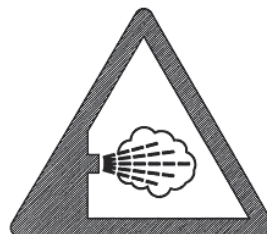

**Warning - safety
valves' vents**



**Warning - high-
temperature zones
Adjacent to hot
pipes or
components**

2.8 Safety regulations

Refrigerant data	Safety data: R410A
Toxicity	Low
Contact with skin	If sprayed, the refrigerant is likely to cause frost burns. If absorbed by the skin, the danger is very limited; it may cause a slight irritation, and the liquid is degreasing. Unfreeze the affected skin with water. Remove the contaminated clothes with great care - in the presence of frost burns, the clothes may stick to the skin. Wash with plenty of warm water the affected skin. In the presence of symptoms such as irritation or blisters, obtain medical attention.
Contact with eyes	Vapours do not cause harmful effects. The spraying of refrigerant may cause frost burns. Wash immediately with a proper solution or with tap water for at least 10 minutes, and then obtain medical attention.
Ingestion	Very unlikely - should something happen, it will cause frost burns. Do not induce vomiting. Only if the patient is conscious, wash out mouth with water and give some 250 ml of water to drink. Then, obtain medical attention.
Inhalation	R410A: remarkable concentrations in the air may have an anaesthetic effect, up to fainting. The exposure to considerable amounts may cause irregular heartbeat, up to the sudden death of the patient. Very high concentrations may result in the risk of asphyxia, due to the reduction in the oxygen percentage in the atmosphere. Remove the patient to fresh air and keep warm and at rest. If necessary, give oxygen. In case of breathing difficulties or arrest, proceed with artificial respiration. In case of cardiac arrest, proceed with cardiac massage. Then, obtain medical attention.
Recommendations	Semiotics or support therapy is recommended. Cardiac sensitisation has been observed that, in the presence of circulating catecholamines such as adrenalin, may cause cardiac arrhythmia and accordingly, in case of exposure to high concentrations, cardiac arrest.
Prolonged exposure	R410A: a study on the effects of exposure to 50,000 ppm during the whole life of rats has identified the development of benign testicle tumour. This situation should therefore be negligible for personnel exposed to concentrations equal to or lower than professional levels.
Professional levels	R410A: Recommended threshold: 1000 ppm v/v - 8 hours TWA.
Stability	R410A: Not specified
Conditions to avoid	Do not use in the presence of flames, burning surfaces and excess humidity.
Hazardous reactions	May react with sodium, potassium, barium and other alkaline metals. Incompatible substances: magnesium and alloys with magnesium concentrations > 2%.
Hazardous decomposition products	R410A: Halogen acids produced by thermal decomposition and hydrolysis.

General precautions	Do not inhale concentrated vapours. Their concentration in the atmosphere should not exceed the minimum preset values and should be maintained below the professional threshold. Being more weighty than the air, the vapour concentrates on the bottom, in narrow areas. Therefore, the exhaust system must work at low level.
Respiratory system protection	If you are in doubt about the concentration in the atmosphere, it is recommended to wear a respirator approved by an accident-prevention Authority, of the independent or oxygen type.
Storage	Cylinders must be stored in a dry and fresh place, free from any fire hazard, far from direct sunlight or other sources of heat, radiators etc. Keep a temperature below 50 °C.
Protective clothing	Wear overalls, protective gloves and goggles or a mask.
Accidental release measures	It is important to wear protective clothing and a respirator. Stop the source of the leak, if you can do this without danger. Negligible leaks can be left evaporating under the sun, providing that the room is well ventilated. Considerable leaks: ventilate the room. Reduce the leak with sand, earth or other absorbing substances. Make sure that the liquid does not channelled into gutters, sewers or pits where the vapours are likely to create a stuffy atmosphere.
Disposal	The best method is recovery and recycling. If this method is not practicable, dispose according to an approved procedure, that shall ensure the absorption and neutralization of acids and toxic agents.
Fire fighting information	R410A: Not flammable in the atmosphere.
Cylinders	The cylinders, if exposed to fire, shall be cooled by water jets; otherwise, if heated, they may explode.
Protective fire fighting equipment	In case of fire, wear an independent respirator and protective clothing.

Lubricant oil data	Safety data: Polyester oil (POE)
Classification	Not harmful
Contact with skin	May cause slight irritation. Does not require first aid measures. It is recommended to follow usual personal hygiene measures, including washing the exposed skin with soap and water several times a day. It is also recommended to wash your overalls at least once a week.
Contact with eyes	Wash thoroughly with a suitable solution or tap water.
Ingestion	Seek medical advice immediately.
Inhalation	Seek medical advice immediately.
Conditions to avoid	Strong oxidising substances, caustic or acid solutions, excess heat. May corrode some types of paint or rubber.
Protection of the respiratory system	Use in well ventilated rooms.
Protective clothing	Always wear protective goggles or a mask. Wearing protective gloves is not mandatory, but is recommended in case of prolonged exposure to refrigerant oil.
Accidental release measures	It is important to wear protective clothing and, especially, goggles. Stop the source of the leak. Reduce the leak with absorbing substances (sand, sawdust or any other absorbing material available on the market).
Disposal	The refrigerant oil and its waste will be disposed of in an approved incinerator, in conformity with the provisions and the local regulations applicable to oil waste.
Fire fighting information	In the presence of hot liquid or flames, use dry powder, carbon dioxide or foam. If the leak is not burning, use a water jet to remove any vapours and to protect the personnel responsible for stopping the leak.
Cylinders	The cylinders exposed to a fire will be cooled with water jets in case of fire.
Fire fighting protective equipment	In case of fire, wear an independent respirator.

3 TRANSPORT, LIFTING AND POSITIONING

Refrigerators are supplied assembled (apart from standard antivibrating rubber supports, that will be installed on site). The equipment are full of refrigerant and oil, in the quantity required for a proper operation.

3.1 Inspection

When the unit is delivered, it is recommended to check it carefully and to identify any damage occurred during transportation. The goods are shipped ex-factory, at the buyer's risk. Check that the delivery includes all the components listed in the order.

In case of damage, note it down on the carrier's delivery note and issue a claim according to the instructions provided in the delivery note.

In the presence of any serious damage, that does not affect the surface only, it is recommended to inform Airwell-Italia immediately.

Please note that Airwell-Italia may not be held liable for any damage to the equipment during transportation, even though the carrier has been appointed by the factory.

3.2 Lifting

The unit must be lifted by using the hooks inserted into the relevant eyebolts (see the figure).

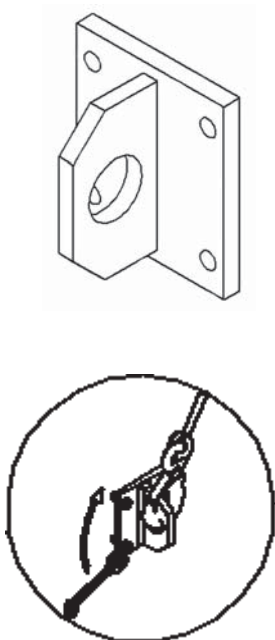

It is recommended to use a spacer to prevent cables from damaging the unit (see the figure).

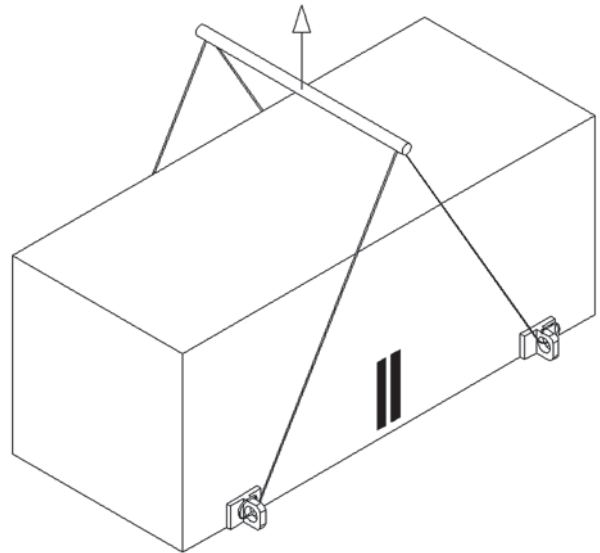

Before positioning the unit, make sure that the place of installation is appropriate and sturdy enough to hold the weight and to withstand the stress caused by the operation of the whole assembly.



Do not displace the unit on rollers, and do not lift it with a lift truck.

**Unit must be lifted carefully.
To lift unit slowly and regularly.**

To lift and displace the unit:

- Insert and secure eyebolts into the holes marked on the frame.
- Insert spacer between cables.
- Hook near the barycentre of the unit.
- The cables must be long enough to form, if tensioned, an angle of at least 45° with respect to the horizontal plane.



For lifting operations, use only tools and material fit for this purpose, in accordance with accident-prevention regulations.



During the lifting and handling of the unit, be careful not to damage the finned pack of the coils positioned on the sides of the unit. The sides of the unit must be protected by cardboard or plywood sheets.



It is recommended not to remove the protective plastic envelope, that should prevent scraps from penetrating into the appliance and any damage to the surfaces, until the unit is ready for operation.



The lifting eyebolts protrude from the base of the unit; it is therefore recommended to remove them once the unit has been lifted and positioned, if in your opinion they are likely to become a source of hazard and injury.

The eyebolts must be mounted on the unit whenever it shall be displaced and then lifted again.

3.3 Anchoring

It is not essential to secure the unit to the foundations, unless in areas where there is a serious risk of earthquake, or if the appliance is installed on the top of a steel frame.

3.4 Storage

When the unit is to be stored before installation, adopt a few precautions to prevent any damage or risk of corrosion or wear:

- plug or seal every single opening, such as water fittings
- do not store the appliance in a room where the temperature exceeds 50°C for the units using R410A and, if possible, do not expose to direct sunlight
- minimum storage temperature is -25 °C
- it is recommended to store the unit in a roof where traffic is minimized, to prevent the risk of accidental damage
- the unit must not be washed with a steam jet
- take away and leave to the site manager all the keys providing access to the control board

Finally, it is recommended to carry out visual inspections at regular intervals.

4 INSTALLATION

4.1 Positioning of the unit



Before installing the unit, make sure that the structure of the building and/or the supporting surface can withstand the weight of the appliance. The weights of the units are listed in Chapter 8 of this manual.

These units have been designed for outdoor installation on a solid surface. Standard accessories include antivibrating rubber supports, that must be positioned under the base.

When the unit is to be installed on the ground, it is necessary to provide a concrete base, to ensure a uniform distribution of the weights.

As a general rule, no special sub-bases are required. However, if the unit is to be installed on the top of inhabited rooms, it is advisable to rest it on spring shock absorbers (optional), that will minimise the transmission of any vibration to the structures.

To choose the place of installation of the unit, bear in mind that:

- the longitudinal axis of the unit must be parallel to the direction of prevailing winds, so as to ensure a uniform distribution of the air on finned exchangers
- the unit must not be installed near boilers' vent pipes
- the unit must not be installed leeward with respect to sources of air contaminated by greases, such as, for example, the outlets to kitchen exhaust hoods into the atmosphere. Otherwise, the grease is likely to deposit on the fins of the refrigerant /air exchangers, and would fix every type of atmospheric impurity, resulting in the quick clogging of the exchangers
- the unit must not be installed in areas subject to considerable snow falling
- the unit must not be installed in areas subject to flooding, under gutters etc.
- the unit must not be installed in air shafts, narrow courts or other small places, where the noise may be reflected by the walls or the air ejected by fans may short-circuit itself on refrigerant/air heat exchangers or condenser
- the place of installation must be have all the necessary spaces for air circulation and maintenance operations (see Chapter 8).

4.2 Spring Isolator Installation

- Prepare the base, that must be flat and plane.
- Lift the appliance and insert shock absorbers as follows:

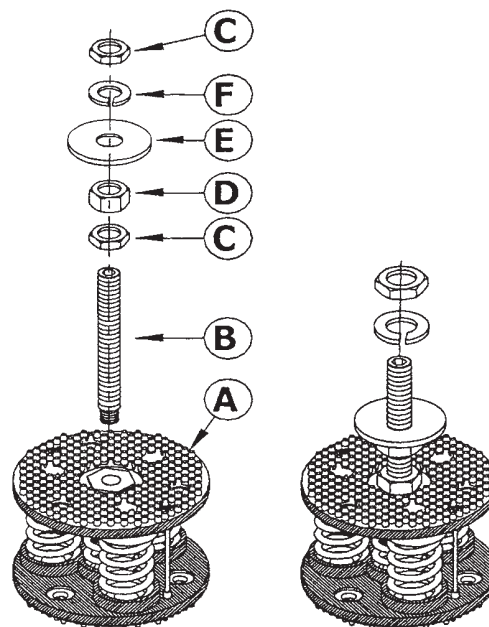

1) Proceed to assemble the jack components.

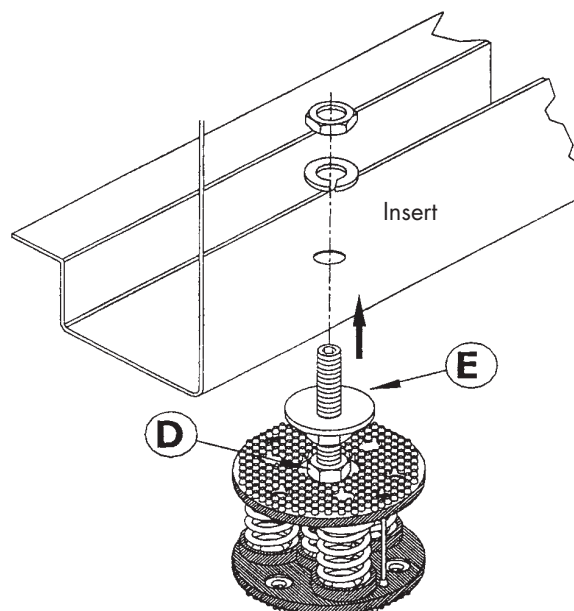

Installation

- 2) Fit the jack in the threaded housing on the upper plate of the antivibration mount. Next fit the jack mounted on the antivibration mount in the hole in the machine base.

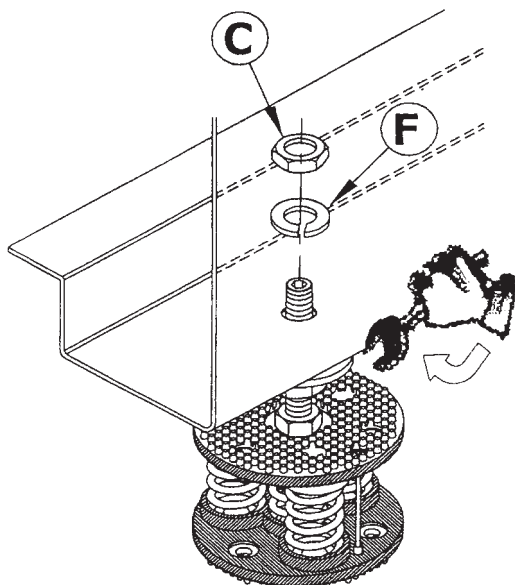

- 3) Make sure the machine base is resting on the flat washer (pos. E) of the jack. To offset any leveling problems, adjust the top nut (pos. D) using an adequate spanner. Lock in position with grower washer (pos.F) and low nut (pos. C).

At the end of this operation, make sure the machine is elastic on the axes and compensating antivibration joints can be fitted in the water connections.

4.3 External hydraulic circuit



The external hydraulic circuit must ensure the water flow to the evaporator under any working or adjustment conditions.

The external hydraulic circuit should consist of the following elements:

- A circulation pump that can ensure the necessary capacity and discharge head.
- The capacity of the primary hydraulic circuit should not be less than 7.5 litres/KW of cooling capacity, in order to prevent the repeated start-up of the compressor and any damage to it. If the water capacity in the primary piping of the circuit and in the evaporator is lower than this value, an

insulated storage tank shall be installed.

- A membrane expansion vessel provided with safety valve with vent, that must be visible.



The capacity of the expansion vessel must allow for an expansion of at least 2% of the volume of the fluid in the circuit (evaporator, piping, user circuit and standby tank, if any). The expansion vessel needs not be isolated, because no water can circulate inside it.

- A flow switch, to disable the appliance when the water is not circulating.



The flow switch must be connected (terminals 1-2) as shown in the wiring diagram of the "User's Terminal Box" (Paragraph 4.7).

To install the flow switch, follow the manufacturer's instructions.

As a general rule, the flow switch shall be mounted on a horizontal pipe, at a distance from the curves equal to 10 times the diameter of the pipe and far from valves or other components that are likely to hinder the water flow upstream of or downstream from the flow switch.

- The bleed valves must be mounted on the highest point of the piping.
- The stop valves must be mounted on the piping of the water entering/leaving the condenser.
- The discharge points (provided with plugs, cocks etc.) must be arranged in the lowest point of the piping.

Then:

- Provide the evaporator with a by-pass circuit equipped with a valve to wash the plant.
- Insulate the piping, to prevent the risk of heat loss.
- Position a filter on the suction side of the evaporator of the heat recovery condenser.

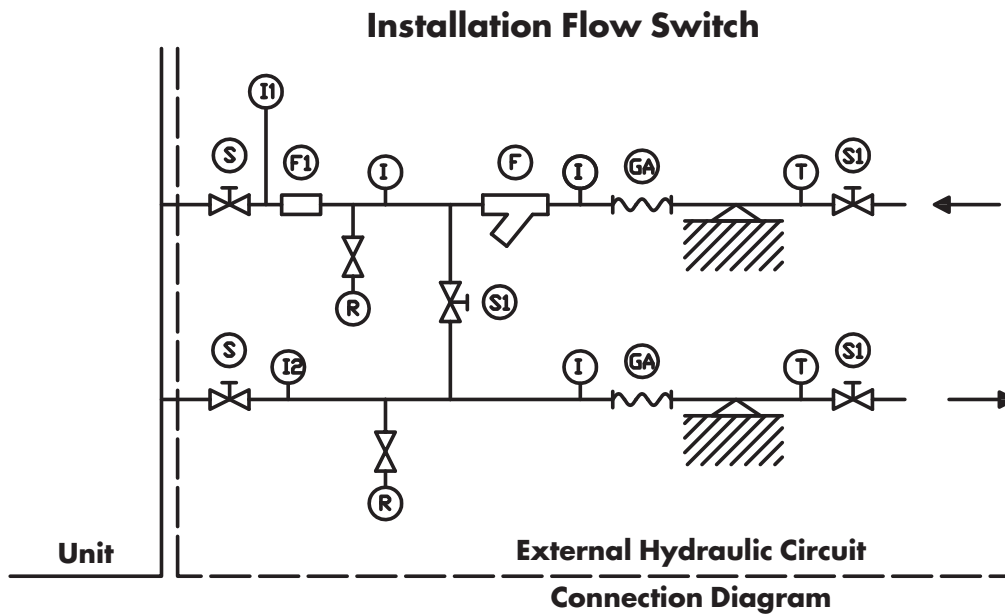

Legends:

I: Pressure gauge connection
 S: Gate valve
 F1: Flow Switch
 GA: Flexible hoses

R: Drain cock
 T: Thermometer
 F: Filter
 I1/I2: Pressure gauge connection to measure pressure drop or head pressure



Before filling the circuit, it is important to check that it is free from any foreign matter, sand, gravels, rust, welding deposits, waste and other materials that may damage the evaporator.

When cleaning the lines, it is recommended to create a circuit by-pass. It is important to mount a filtering medium (30 mesh) upstream of the chiller.



If necessary, the water required to fill the circuit must be treated to obtain the requested PH.

4.4 Hydraulic connection

The water inlet/outlet fittings shall conform to the instructions provided by the plates affixed near the connection points.

4.5 Draining the defrosting waste water (for heat pump unit only)

When heat pump units work in heating mode, during defrosting cycles, they may discharge water from the base. This is why the units should be installed at least 200 mm above the floor level, so as to allow the free drainage of waste water, without the risk of producing ice banks.

The heat pump units must be installed in positions where the defrosting water cannot create any damage.

Installation

4.6 Power supply



Before carrying out any operations on the electrical system, make sure that the unit is deenergised.



It is important that the appliance is grounded.



The company in charge of the installation shall conform to the standards applicable to outdoor electrical connections.

Airwell-Italia may not be held liable for any damage and/or injury caused by failure to comply with these precautions.

The unit conforms to EN 60204-1.

The following connections shall be provided:

- A 3-phase and grounding connection for the power supply circuit.
- The electrical distribution system shall meet the power absorbed by the appliance.
- The disconnecting and magnetothermal switches must be sized to control the starting current of the unit.
- The power supply lines and the insulation devices must be designed in such a way that every line independent.
- It is recommended to install differential switches, to prevent any damage caused by phase drops.
- The fans and compressors are supplied through contactors controlled from the control panel.
- Each motor is provided with an internal safety thermal device and external fuses.
- The power supply cables must be inserted into dedicated openings on the front of the unit, and they will enter the electrical board through holes drilled on the bottom of the board.

4.7 Electrical connections

The unit must be installed on site according to the Machinery Directive (98/37/EC), the Low Voltage Directive (Low voltage directive 2006/95/EC), the Electromagnetic Interference Directive (89/336/EC) and the usual procedures and standards applicable in the place of installation. The unit must not be operated if its installation has not been carried out according to the instructions provided in this manual.

The power supply lines must consist of insulated copper conductors, dimensioned for the maximum absorbed current.

Connection to terminals must be performed according to the diagram of connections (User's Terminal Box) provided in this manual and according to the wiring diagram which accompanies the unit.



Before connecting the power supply lines, check that the available voltage value does not exceed the range specified in the Electric Data (Chapter 8).

For 3-phase systems, check also that the unbalance between the phases does not exceed 2%. To perform this check, measure the differences between the voltage of each phase couple and their mean value during operation. The maximum % value of these differences (unbalance) must not exceed 2% of the mean voltage.

If the unbalance is unacceptable, contact the Energy Distributor to solve this problem.



Supplying the unit through a line whose unbalance exceeds the permissible value will automatically void the warranty.

AQTL/AQTH Version – Electrical Connections

QG - Y1

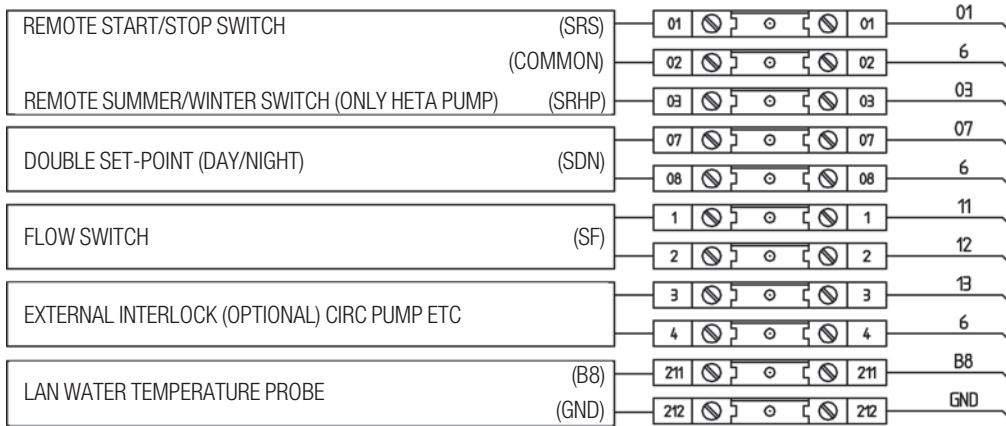

QG - Y2

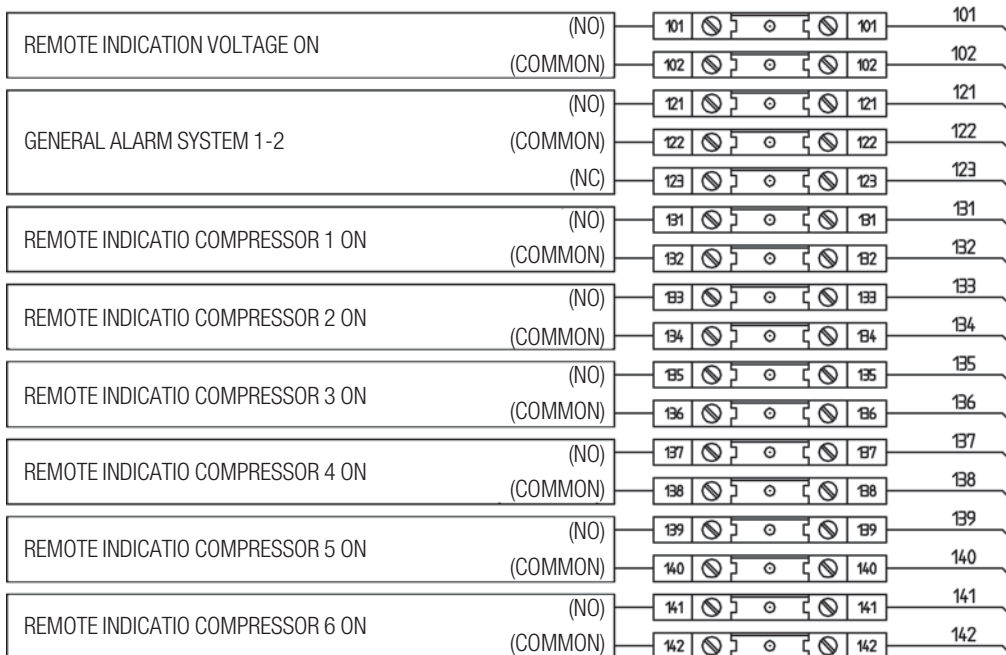

QG - Y3

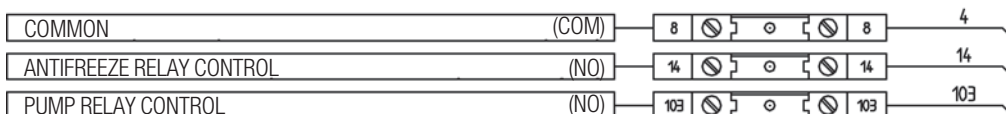

4.8 Connecting plate-type evaporator temperature sensors

AQTL, AQTH and AQTR units are provided with fittings for hydraulic connections between heat exchangers and plant. Each fittings is complete with sensor well to fasten temperature sensor (BT-IN and

BT-OUT). Fittings are supplied separate and must be mounted during the installation of the unit, as explained in the instruction below.

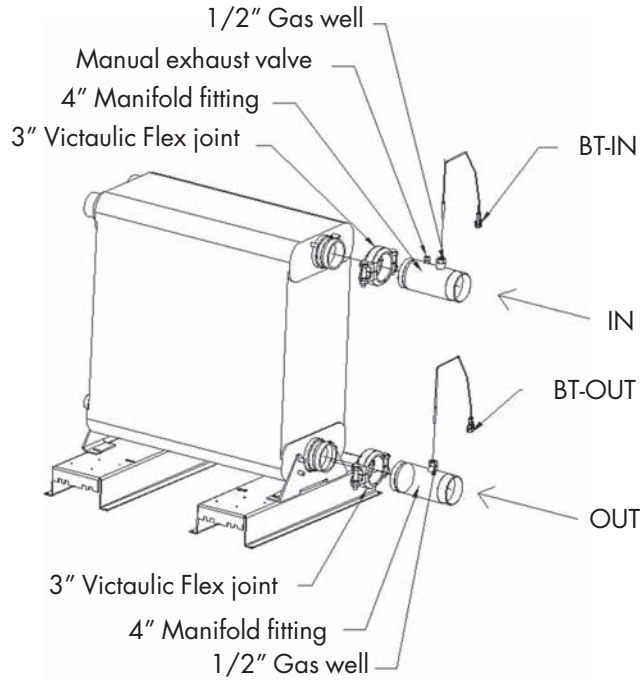

Connecting the plate type evaporator's temperature sensors (version with pump)

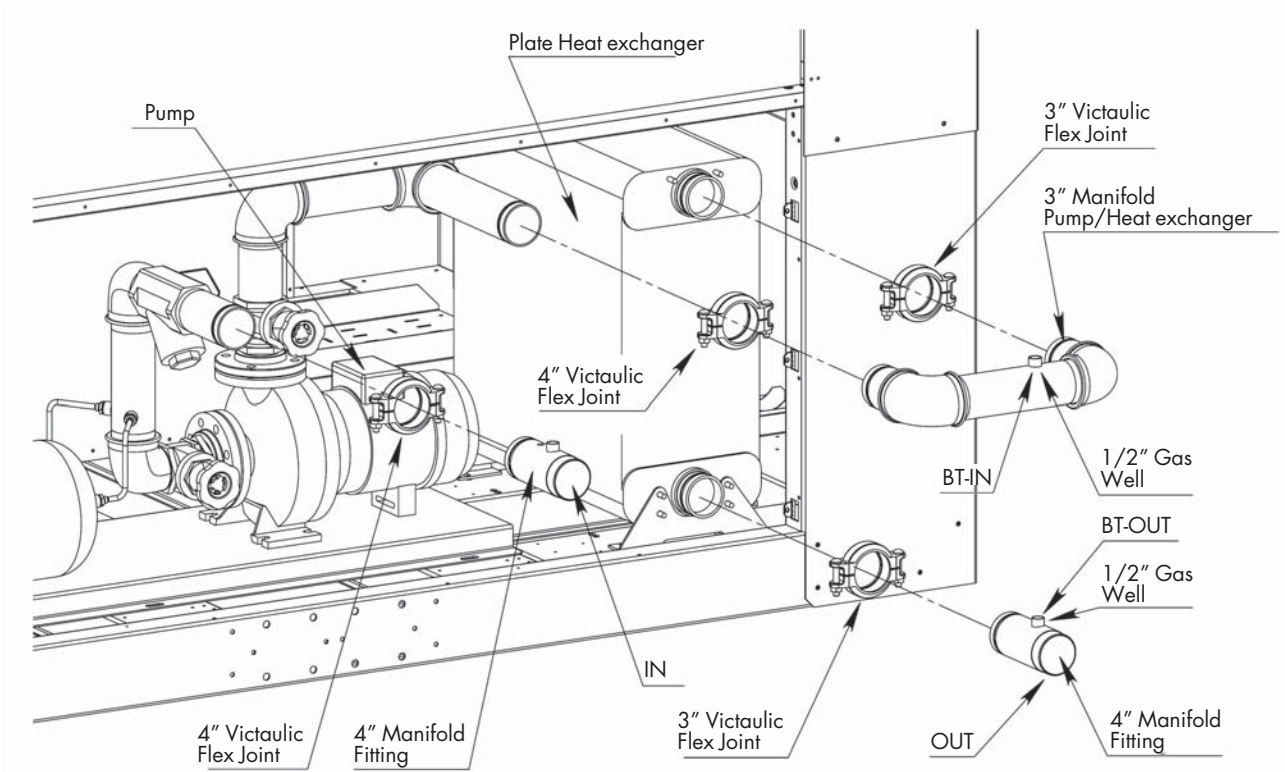

Connecting the plate type evaporator's temperature sensors (version with pump and buffer tank)

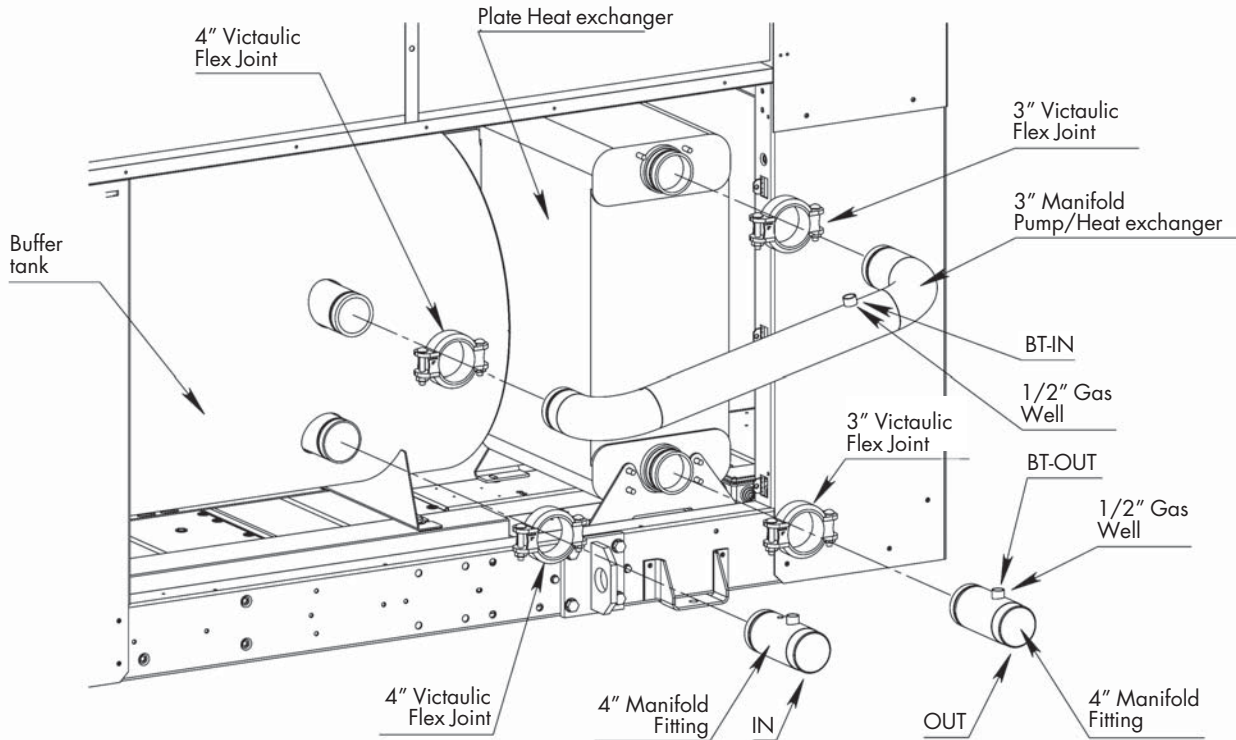

4.9 Total heat recovery features

Temperature sensors

Temperature sensors for recovery system water control, BTRin e BTRout, are supplied by factory with the unit, already wired, and must be fitted on the water connections at the heat reclaim condenser inlet and outlet (see wiring diagram).

Three-way valve

The three-way valve must be installed on-site. It permits bypassing the heat reclaim condenser for correct operation at low return water temperature. Water and electrical connections, as well as thermal insulation must be made at the time of installation on-site.

The best position is close to heat reclaim condenser (to achieve a small water circuit).

NOTE: The space required by this valve does not permit installation on the factory

Forced shuttering

When recovery system is on, a commutation from air condensing and water condensing takes place. At the same time compressor-tandem is automatically shuttered to allow the control of condensation in the transient phase. The same process takes place when the system commutates from water condensing to air condensing.

5 START-UP



The unit must be started for the first time by personnel suitably trained by one of Airwell-Italia's Authorised Service Centre. Failure to meet this requirement will immediately void the warranty.



The operations carried out by Airwell-Italia personnel are limited to the start-up of the unit, and do not include any other operation on the plant, such as, for example, electrical and hydraulic connections etc. All the other operations before start-up, including oil pre-heating for at least 12 hours, must be performed by the Installer.

5.1 Preliminary check

The checks listed below shall be performed before starting the unit and before the arrival of the personnel authorised by Airwell-Italia.

- Check the section of power supply and grounding cables; make sure that terminals are tightened and check the correct operation of contactors, with the master switch open.
- Check that any voltage and phase variation in the power supply does not exceed the prefixed thresholds.
- Connect the contacts of the flow switch and the thermal relay of the pump and of the other devices (if any), to terminals 1-2 and 3-4, respectively.
- Check that the components of the external water circuit (pump, user equipment, filters, power supply tank and reservoir, if any) have been installed properly, and according to the manufacturer's instructions.
- Check the filling of the hydraulic circuits, and make sure that the fluid circulation is correct, without any trace of leaks and air bubbles. If you use ethylene glycol as antifreeze, check that its percentage is correct.
- Check that the direction of rotation of the pumps is correct, and that fluids have been circulating for at least 12 hours for both pumps. Then, clean the filters on the suction side of the pumps.
- Adjust the liquid distribution network in such a way that the flow rate is within the specified range.
- Check that the water quality is up to the specifications.
- Check that oil heaters, if any, have been turned on at least 12 hours before.

5.2 Start-up

Start-up sequence:

- Turn on the master switch (at least 12 hours before).
- Check that the oil in the compressor has reached the requested temperature (the minimum temperature outside the pan must be approx. 40°C) and that the auxiliary control circuit is energised.
- Check the operation of all the external equipment, and make sure that the control devices of the plant are properly calibrated.
- Start the pump and check that the water flow is correct.
- Set the desired fluid temperature on the control board.
- Start the appliance (see Chapter 6).
- Check the correct direction of rotation of compressors. Scroll compressors cannot compress the refrigerant when they rotate in the opposite direction. To make sure that they are rotating in the correct direction, simply check that, just after the start-up of the compressor, the pressure drops on the LP side and rises on the HP side. Furthermore, if a scroll compressor rotate in the opposite direction, there is a considerable rise in the sound level of the unit, as well as in a dramatic reduction of current absorption compared to normal values. In case of wrong rotation, the scroll compressor can be definitely damaged.
- After about 15 minutes of operation check that there are no bubbles, through the sight glass on the liquid line.



The presence of bubbles may indicate that a part of the refrigerant charge has been released in one or more points. It is important to remove these leaks before proceeding.

- Repeat the start-up procedure after removing the leaks.
- Check the oil level in the compressor's sight glass.

5.3 Checking the operation

Check the following:

- The temperature of the water entering the evaporator.
- The temperature of the water leaving the evaporator.
- The level of the water flow rate in the evaporator, if possible.
- The current absorption upon the start of the compressor and in case of stabilised operation.
- The fan's current absorption.

Check that the condensing and evaporation temperatures, during operation at high and low pressure detected by the pressure gauges of the refrigerant, are within the following range:
(On the units not provided with HP/LP pressure gauges for the refrigerant, connect a pressure gauge to the Shrader valves on the refrigeration circuit).

HP side	Approx. 15 to 21°C above the temperature of the air entering the condenser, for R410A units.
LP side	Approx. 2 to 4°C below the temperature of the leaving chilled water, for R410A units.

5.4 Delivery to the customer

- Train the user according to the instructions provided in Section 6.

6 GENERAL INFORMATION

Introduction

This document contains the information and the operating instructions for AQT.

This information is for the after-sales service and the production operators, for the end-of-line testing.

Main Characteristics

- Microprocessor control
- User-friendly keyboard
- Proportional and integral control of the return water temperature (RWT)
- Hysteresis control of the leaving water temperature (LWT)
- Access code to enter the Manufacturer's Level
- Access code to enter the Assistance Level
- Alarm and LED
- Backlighted LCD
- Closed-loop condensing pressure control
- Pump-Down logic (start-stop)
- Rotation of the compressor operation
- Oil return function
- Night mode (or Low Noise) control
- Counting of the pump/compressors' hours of operation
- Display and control of superheating by EEV
- Display of discharge and suction pressure values
- History of stored alarms (option)
- Programming of different setpoints with 4 ranges of time/setpoint.

The following accessories can be also connected:

- Real Time Clock Memory Card: alarm history and programming of different setpoints with ranges of time
- Serial Communication RS485 Card; to connect the **Chiller Control** to a BMS network
- Remote Display Terminal
- Wire Remote Control

6.1 Control of AQT The "CHILLER CONTROL" system

The AQT machines are provided with a microprocessor card which is fully programmed in factory for the control of a chiller with 2 circuits, 2/3 compressors per circuit, a high-pressure transducer per circuit, electronic expansion valve.

Keyboard & Display Terminal

General information

The figure shows the terminal with the front door open.

It is provided with a LCD 4 lines x 20 columns, keyboard and microprocessor-controlled LED's, so as to allow the programming of the control parameters (setpoint, differential bands, alarm thresholds) and themain operations to be carried out by the user.

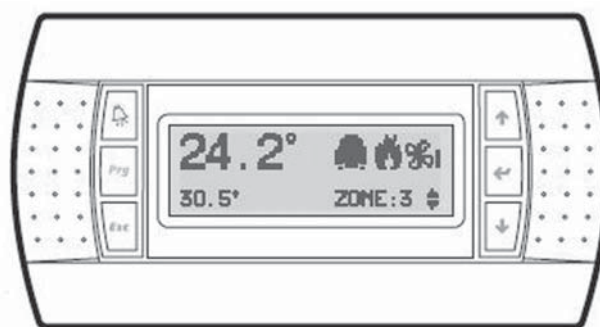

Terminal & Key Board description

The terminal makes it possible to carry out the following operations:

- the initial configuration of the machine
- the change of all the main operating parameters
- the display of the detected alarms
- the display of all the measured quantities

The terminal and the card are connected by a 6-way phone cable.

The connection of the terminal to the basic card is not essential for the normal operation of the controller.



Access to the "display mask" of the machine status.

Utente
Costruttore
Manutenzione
In/Out

Setpoint
Versione
Fasce orarie



Esc key: allows you to move from one mask to another.



Alarm key: used to display the alarms, to reset them in manual. Press it one to display the mask of the activated alarm, press it again to reset the alarm signal.



Prg-Esc keys: Pressing these keys at the same time, allows you to turn the unit on/off.



Up-Down keys: allows you to set the control parameters' values and to move from one mask to another (not backlighted).



Enter key: used to move the cursor inside the masks and to save the values of the set parameters.



Alarm-Enter keys: Press these keys at the same time to enter the "historical alarm" after 1' come back at status machine menu'.

6.2 Display

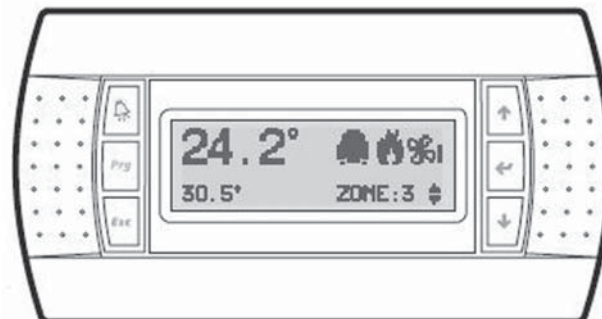

The display is an LCD 4 lines x 20 columns. The quantities and the information about the operation of the unit are alternated in the form of subsequent screens, named.

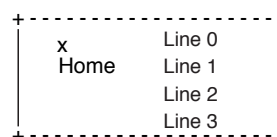

6.3 Keyboard

Arrows key - Up/Down/Enter

If the cursor is in the top left-hand corner (Home), press the UP/DOWN keys to access the subsequent masks associated to the selected branch. If a mask includes some value setting fields and you press the ENTER key, the cursor will reach these fields. Once you have reached the quantity setting field, you can modify any value (within the expected limits) by pressing the UP/DOWN keys. After you have selected the desired value, press the ENTER key again to store it.

■ Alarms



Alarm	Description	Comp Circ 1 Status	Comp Circ 2 Status	Fan Circuit 1 Status	Fan Circuit 2 Status	Pump Status	Reset out/man
AL01	Power supply wrong	OFF	OFF	OFF	OFF	OFF	MAN
AL02	Antifreeze alarm	OFF	OFF	OFF	OFF	OFF	MAN
AL03	Interlock	OFF	OFF	OFF	OFF	OFF	MAN
AL04	Lack of flow	OFF	OFF	OFF	OFF	OFF	AUTO 1/hour
AL05	SYS #1 Low suction pressure	OFF	ON	OFF	ON	ON	AUTO 1/hour
AL06	SYS #2 Low suction pressure	ON	OFF	ON	OFF	ON	AUTO 1/hour
AL07	SYS #1 High pressure supply	OFF	ON	OFF	ON	ON	AUTO 1/hour
AL08	SYS #2 High pressure supply	ON	OFF	ON	OFF	ON	AUTO 1/hour
AL91	SYS #1 Thermal compressor 1	OFF COMP1	ON	ON	ON	ON	AUTO 1/hour
AL92	SYS #1 Thermal compressor 2	OFF COMP2	ON	ON	ON	ON	AUTO 1/hour
AL93	SYS #1 Thermal compressor 3	OFF COMP3	ON	ON	ON	ON	AUTO 1/hour
AL101	SYS #2 Thermal compressor 1	ON	OFF COMP1	ON	ON	ON	AUTO 1/hour
AL102	SYS #2 Thermal compressor 2	ON	OFF COMP2	ON	ON	ON	AUTO 1/hour
AL103	SYS #2 Thermal compressor 3	ON	OFF COMP3	ON	ON	ON	AUTO 1/hour
AL11	Recovery antifreeze alarm	Recovery disabled					
AL141	SYS #1 Thermal cond.fans 1	OFF	ON	OFF	ON	ON	MAN
AL142	SYS #1 Thermal cond.fans2	OFF	ON	OFF	ON	ON	MAN
AL151	SYS #2 Thermal cond.fans 1	ON	OFF	OFF	ON	ON	MAN
AL152	SYS #2 Thermal cond.fans2	ON	OFF	OFF	ON	ON	MAN
AL16	SYS #1 Compressor diff.press.alarm	OFF	ON	OFF	ON	ON	MAN
AL17	SYS #2 Compressor diff.press.alarm	ON	OFF	ON	OFF	ON	MAN
AL21	Remote setpoint out of range	OFF	OFF	OFF	OFF	OFF	MAN
AL22	Press.suction SYS1 Sensoralarm	OFF	ON	OFF	ON	ON	AUTO 1/hour
AL23	Press.discharge SYS1 Sensoralarm	OFF	ON	OFF	ON	ON	MAN
AL24	Temp.Return Water Damaged Sensor	OFF	OFF	OFF	OFF	OFF	MAN
AL25	Temp Leaving Water Damaged Sensor	OFF	OFF	OFF	OFF	OFF	MAN
AL26	Press Suction SYS2 Sensoralarm	ON	OFF	ON	OFF	ON	MAN
AL27	Press.Discharge SYS2 Sensoralarm	ON	OFF	ON	OFF	ON	MAN
AL28	Temperatur Chill.net Sensoralarm	OFF	OFF	OFF	OFF	OFF	MAN
AL29	Temperatur Coil SYS1 Sensoralarm	OFF	ON	OFF	ON	ON	MAN
AL30	Temperatur Coil SYS2 Sensoralarm	ON	OFF	ON	OFF	ON	MAN
AL301	Outdoor Air Temper. Sensoralarm	OFF	OFF	OFF	OFF	OFF	MAN
AL302	Temp.Discharge SYS1 Sensoralarm	OFF	ON	OFF	ON	ON	MAN
AL303	Temp.Discharge SYS2 Sensoralarm	ON	OFF	ON	OFF	ON	MAN
AL304	Temp.Return Recovery Sensoralarm	OFF	OFF	OFF	OFF	OFF	MAN
AL305	Temp Leaving Recovery Sensoralarm	OFF	OFF	OFF	OFF	OFF	MAN
AL311	SYS #1 compressor 1 maintenance	ON	ON	ON	ON	ON	MAN
AL312	SYS #1 compressor 2 maintenance	ON	ON	ON	ON	ON	MAN
AL313	SYS #1 compressor 3 maintenance	ON	ON	ON	ON	ON	MAN
AL321	SYS #2 compressor 1 maintenance	ON	ON	ON	ON	ON	MAN
AL322	SYS #2 compressor 2 maintenance	ON	ON	ON	ON	ON	MAN
AL323	SYS #2 compressor 3 maintenance	ON	ON	ON	ON	ON	MAN
AL33	Evaporator Pump Maintenance	ON	ON	ON	ON	ON	MAN
AL44	pCOe disconnected	ON	ON	ON	ON	ON	MAN
AL45	Analog input probe channel 1 broken	OFF	OFF	OFF	OFF	OFF	MAN
AL46	Analog input probe channel 2 broken	OFF	OFF	OFF	OFF	OFF	MAN
AL47	Analog input probe channel 3 broken	OFF	OFF	OFF	OFF	OFF	MAN
AL48	Analog input probe channel 4 broken	OFF	OFF	OFF	OFF	OFF	MAN
AL51	EEV Motor error (check wirings) SYS1	OFF	ON	OFF	ON	ON	MAN
AL52	MOP timeout (check timeout) SYS1	OFF	ON	OFF	ON	ON	MAN
AL53	LOP timeout (check timeout) SYS1	OFF	ON	OFF	ON	ON	MAN
AL54	Low SuperHeat (check timeout)	OFF	ON	OFF	ON	ON	MAN

Control

Alarm	Description	Comp Circ 1 Status	Comp Circ 2 Status	Fan Circuit 1 Status	Fan Circuit 2 Status	Pump Status	Reset aut/man
AL55	High SuperHeat (check timeout)	OFF	ON	OFF	ON	ON	MAN
AL56	EEV not closed during power OFF	OFF	ON	OFF	ON	ON	MAN
AL57	Probe S1 error	OFF	ON	OFF	ON	ON	MAN
AL58	Probe S2 error	OFF	ON	OFF	ON	ON	MAN
AL59	Probe S3 error	OFF	ON	OFF	ON	ON	MAN
AL60	EVD Gohead request (maintenance menu)	OFF	ON	OFF	ON	ON	MAN
AL61	Lan disconnected	OFF	ON	OFF	ON	ON	MAN
AL62	Auto Setup Procedure not completed	OFF	ON	OFF	ON	ON	MAN
AL63	EEprom error	OFF	ON	OFF	ON	ON	MAN
AL64	EEV Motor error (check wirings)	ON	OFF	ON	OFF	ON	MAN
AL65	MOP timeout (check timeout)	ON	OFF	ON	OFF	ON	MAN
AL66	LOP timeout (check timeout)	ON	OFF	ON	OFF	ON	MAN
AL67	Low SuperHeat (check timeout)	ON	OFF	ON	OFF	ON	MAN
AL68	High SuperHeat (check timeout)	ON	OFF	ON	OFF	ON	MAN
AL69	EEV not closed during power OFF	ON	OFF	ON	OFF	ON	MAN
AL70	Probe S1 error	ON	OFF	ON	OFF	ON	MAN
AL71	Probe S2 error	ON	OFF	ON	OFF	ON	MAN
AL72	Probe S3 error	ON	OFF	ON	OFF	ON	MAN
AL73	EVD Gohead request (maintenance menu)	ON	OFF	ON	OFF	ON	MAN
AL74	Lan disconnected	ON	OFF	ON	OFF	ON	MAN
AL75	Auto Setup Procedure not completed	ON	OFF	ON	OFF	ON	MAN

■ Setpoint

Pressing the Set key allows you to enter the Set point level accessible to the user. The parameters that can be set are listed below, along with the limit values and the default values (standard shop settings):

User parameters	Control mode	Min value	Max value	Default
Cooling Setpoint	RWT Return Control	8	20	10
	LWT Leaving Control	6	20	8
Cooling Setpoint - glycol water	RWT Return Control	-15	20	10
	LWT Leaving Control	-15	20	8
Proportional band Neutral band	RWT Return Control	1	10	5
	LWT Leaving Control	1	6	2
Heating Setpoint	RWT Return Control	20	45	40
	LWT Leaving Control	20	50	40
Languages	--	ITA ENG FRE GER SPA		ITA
System On/Off				
System 1 #	--	OFF	ON	OFF
System 2 #	--	OFF	ON	OFF
Unit Management		Cooling	Heating	

Control

6.4 Protection and Safety Equipment

Defrosting System (only for AQTH models)

The AQTH units are provided with an automatic defrosting system, which prevents the formation of excessive ice banks on coolant/air exchangers during heat pump operation.

This system, which is part of the electronic control system, is of the time/suction pressure type, and when the suction pressure detected by a sensor drops below a fixed limit, once the preset time is over, switches from heating to cooling the operation of the unit, with the fans stopped.

During the defrosting cycle the compressor works normally, but the coil's fans remain off. The defrosting cycle stops after the coil has been defrosted, and at this point the unit can work in heating mode again.



For safety purposes, fans are started also during defrosting, if the discharge pressure reaches considerable values.

Frost Protection for the Chilled Fluid

These units are provided with frost protection for the chilled fluid. This protection consists of an electrical resistor positioned in contact with the coolant/circulating fluid exchanger, which is activated (although the unit is off) when the temperature of the fluid drops below 5 °C - the standard value for a non-glycol unit.

If the leaving water temperature drops below 4 °C (standard value for a non-glycol unit) the machine's antifreeze alarm is activated. If the circulating fluid is water, before the beginning of the cold season it is advisable to drain the circuit to prevent water frosting.

If the circuit cannot be drained, it is essential to avoid de-energizing the unit, so as to permit the activation, when necessary, of the frost protection.

Compressor protection

Compressors are equipped with a heating element to prevent oil dilution, which may result in remarkable risks of failure of compressors.

The windings of the compressors' motors are provided with a thermal protection.

For AQT models an accessory kit for thermal protection is available, for any overcurrent of scroll compressors, which shall be shop-mounted.

Electrical flow switch

To ensure the correct operation of the unit, a electrical flow switch must be installed, to prevent the unit working in case of insufficient circulation of the chilled fluid.



The electrical flow switch must be carefully installed, according to the instructions given by the Manufacturer.

The electrical flow switch must be installed on the pressing side of the circulation pump for the fluid, just upstream of the heat exchanger's inlet. The electrical flow switch must be installed in a horizontal straight length of piping, in a position reasonably far (both upstream and downstream) from localized pressure drops (curves, valves etc.).

Continuous Regulation of the Fan Speed

The fans' speed regulator, if installed, allows the unit to work at an ambient temperature down to -18 °C.

Differential pressure switch

This pressure switch halts the operation of the unit in the event that it does not detect a sufficient pressure drop through the exchanger.

6.5 HPF version configuration

Units equipped with special brushless fans (HPF) can be set-up on the field to give the unit a specific static pressure.

By entering parameter in service level - Max Speed (Vdc) - it is possible to modify high static pressure.

The table below shows the correspondance between chiller model, fan RPM, high static pressure.

Size	Fan Static Pressure [Pa]	Fan RPM	Parameter in Service Level: Max Speed (Vdc)
1206	0	900	7,6
	30	950	8,1
	55	1000	8,5
	85	1050	8,9
	120	1110	9,4
1355	0	900	7,6
	25	950	8,1
	55	1000	8,5
	85	1050	8,9
	120	1110	9,4
1506	0	900	7,6
	25	950	8,1
	50	1000	8,5
	80	1050	8,9
	120	1110	9,4
1656	0	900	7,6
	15	950	8,1
	45	1000	8,5
	80	1050	8,9
	120	1110	9,4
1806	0	900	7,6
	10	950	8,1
	40	1000	8,5
	75	1050	8,9
	120	1110	9,4
2106	0	900	7,6
	15	950	8,1
	45	1000	8,5
	80	1050	8,9
	120	1110	9,4
2406	0	900	7,6
	10	950	8,1
	40	1000	8,5
	75	1050	8,9
	120	1110	9,4

General Description

7 GENERAL DESCRIPTION

7.1 Introduction

AQT units are water chillers /air-water heat pumps provided with hermetic scroll compressors with two refrigeration circuits.

These units are fit for cooling and heating intermedia-

te fluids (glycoled water), for air-conditioning applications in industrial processes.

These units can be installed outdoor on the roof of a building or at ground level.

This series includes the following versions:

Version (STD/HSE ¹)	Description
Base Low Noise version (BLN ²) Low Noise version (LN) Extra Low Noise version (ELN) High Temperature version (HT)	Air condensing chillers/heat pumps, using R410A refrigerant.

¹ High efficiency Units (HSE) with brushless fans

² A High Pressure Fan (HPF) version is available

For each AQT version, the corresponding condensing unit version (AQTC) is available

Available options:

Options	Description
AQTL/D AQTH/D	The heat recovery is carried out by a desuperheater mounted on the compressor's discharge line.
AQTR	Total heat recovery is carried out by a heat exchanger mounted on the compressor's discharge line in parallel with the condensing circuit. Heat recovery function is activated by mean of a 4-ways valve.

7.2 General specifications

AQT units are supplied complete and provided with all connecting pipes for the refrigerant and internal wiring.

The refrigeration circuit of each unit undergoes a pressure test, is drained, vacuumised, dehydrated and filled with refrigerant, and includes the necessary oil. Once assembled, each unit is subjected to a complete final testing and the correct operation of all refrigeration circuits is checked.

The base and the frame of each unit are made of very thick galvanised sheet, and are secured by screw and stainless bolts. All panels are secured by screw and tropicalised steel bolts, they can be disassembled for easy access to internal components.

All galvanised steel parts are painted with white polyester resin (RAL 9001), to ensure the resistance of the unit to corrosion and weather agents over time.

7.3 Compressors

These units are provided with hermetic scroll compressors, with built-in motor protection.

Compressors are mounted on shock absorbers to reduce vibrations. Motors are of direct start-up type, cooled by the sucked refrigerant gas.

Thermistors protect the windings from any overtemperatures and the electronic control checks that the delivery temperature is within the permissible range.

The capacity control, as well as the control of the delivered cooling capacity, are always ensured by the electronic control.

7.4 Refrigeration circuits

Each unit has two complete refrigeration circuits, including: a service valve to fill the unit with refrigerant, shut-off valves, thermostatic expansion valve, dehydrating filter, sight glass with humidity indicator, a differential pressure switch for the water.

The outdoor AQTC units, deriving from the AQTL versions, are marked by the absence of the evaporator, and are equipped with shutoff cocks on the suction line and on the liquid line, so as to allow the connection of remote evaporators.

Furthermore, each circuit is equipped with safety devices in accordance with PED 97/23/EC: HP and LP pressure switches, safety valves providing protection in case of fire or malfunction of compressors.

7.5 Water heat exchanger

The evaporators are of stainless steel plate type.

Their thermal insulation is ensured by a thick flexible closed-cell heat-insulating jacket. Furthermore, the frost protection is ensured by electric heaters.

These exchangers can work at pressures up to 10 bar on the hydraulic side and 30 bar on the refrigerant side.

General Description

The hydraulic connections to the evaporator are of 3" Victaulic type.

7.6 Air heat exchanger

Coils are made of copper pipes in staggered rows, mechanically expanded inside an aluminium finned pack.

7.7 Fans

Fans are of directly coupling propeller type, provided with aluminium blade with wing profile. Each fan is provided with galvanised steel accident-prevention guard. Finally, motors are completely closed, protection class IP54, protection thermostat immersed in windings.

AQTL refrigeration diagram

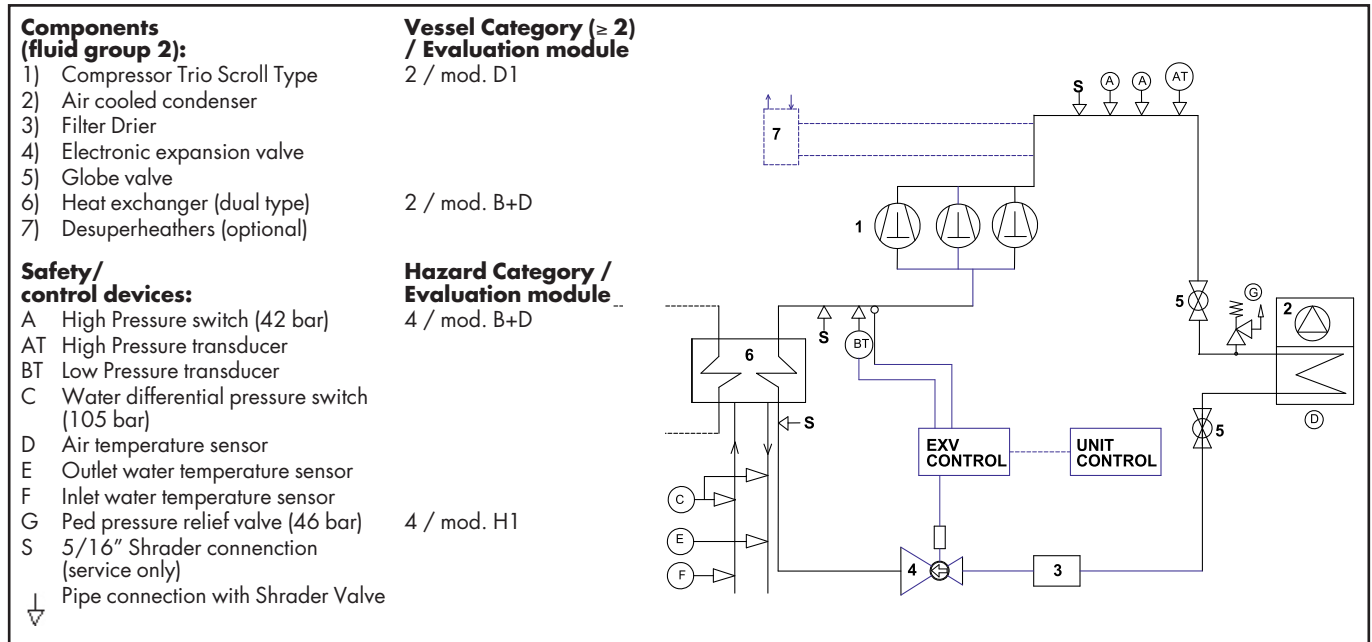

AQTH refrigeration diagram

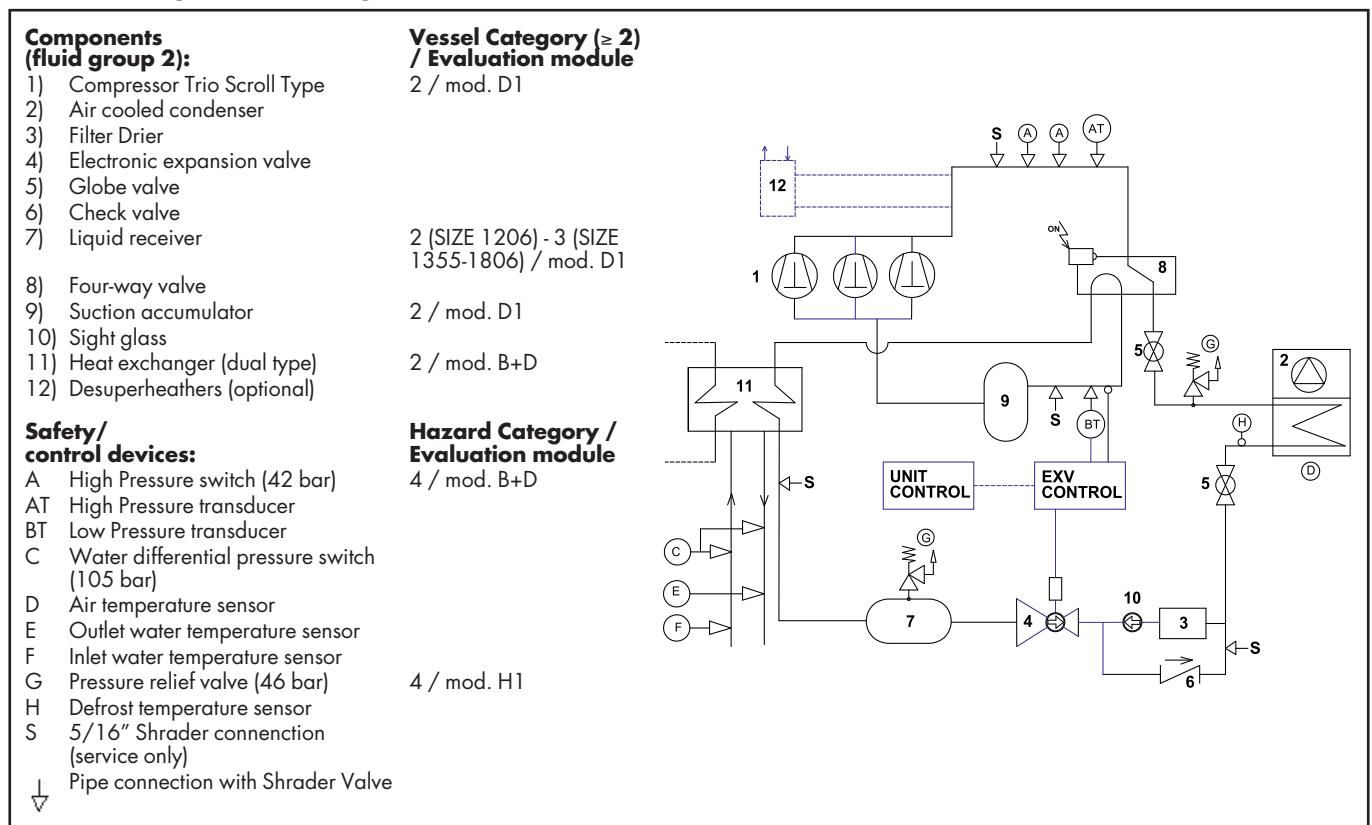

AQTC refrigeration diagram

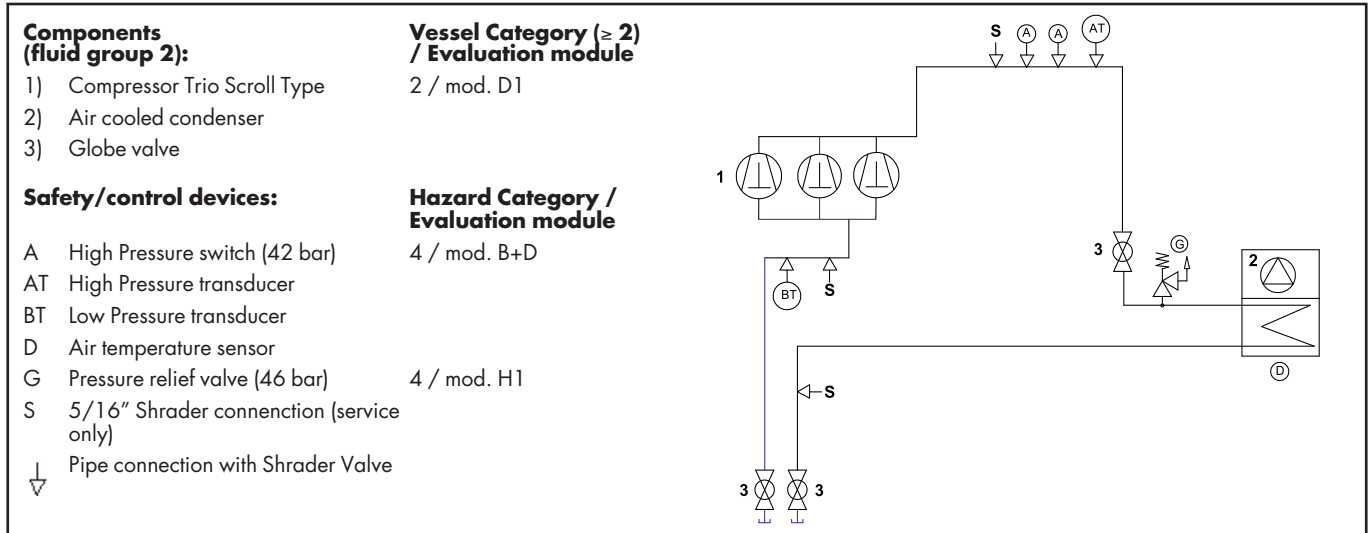

AQTR refrigeration diagram

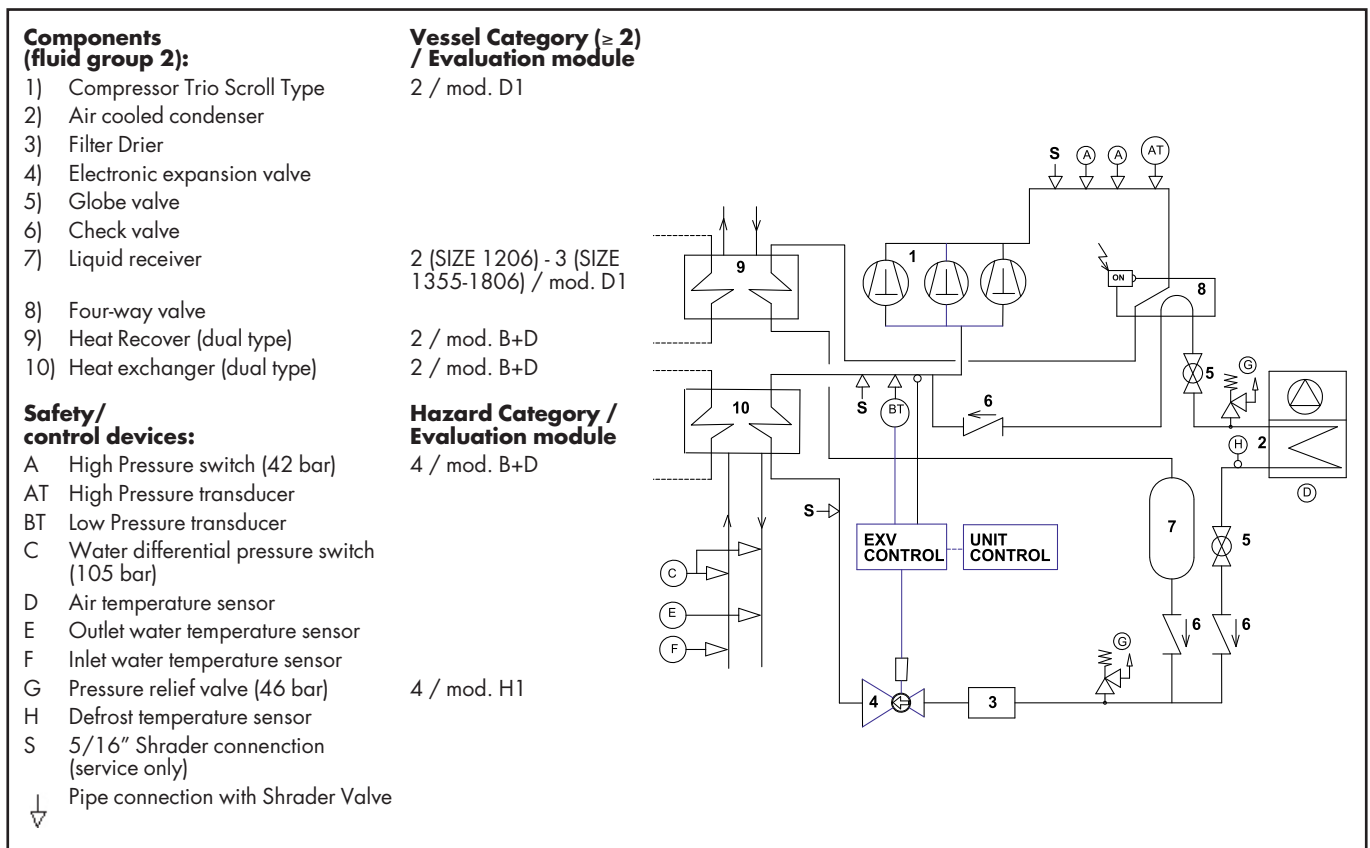

7.8 Electric power supply and control system

The control compartment contains an electronic card with keyboard and a display for working parameters, alarms, if any, and operating blocks. It is complete with remote control switches and protection fuses for the motors of compressors, fans and pumps.

7.9 Accessories

List of available accessories, provided separately, to be mounted on site by the installer:

Water flow switch

Prevents the operation of the unit when the chilled fluid is insufficient. It is advisable to install a flow switch, to ensure the correct operation of the unit.

Water filter

Filter to be mounted on the suction side of the water heat exchanger.

Antivibrating supports (AVM)

Isolating spring supports, equipped with bolts for fastening to the base. They are supplied separated from the unit and must be mounted on site by the customer, at his own expense.

Fan speed regulator

The speed regulator of the fans is mounted as a standard accessory for the Extra Low Noise units, and is an optional accessory for the Standard and Low Noise units. The fan speed is controlled in order to work at a low room temperature, and allows the unit to work down to a room temperature of -18°C . The control can be of the pressostatic step type, with temperature correction, or of continuous type (under pressure), with electronic regulator. The regulator is of electronic type only for the Extra Low Noise versions.

Wire-type remote control kit

The kit includes a remote control for wall mounting, complete with 3m-long connecting cable, and installation manual and a transformer. For longer distances (i.e. up to 50m) you can use a multipolar cable of minimum section (0.25mm). Conductors should be connected directly and according to the diagram which accompanies the installation instructions.

Remote wall terminal

Makes it possible to check the unit through a remote terminal, up to a maximum distance of 200 meters.

RS-485 serial card (for MODBUS or LONWORK or BACNET)

A communication interface makes it possible to control and manage the unit from a local station, with RS485 connection, up to a distance of 1,000m. It is possible to obtain the remote control and the management, by inserting the control into the management plant of the building.

8 TECHNICAL DATA

8.1 Pressure drops

PRESSURE DROP IN THE EVAPORATOR*								
		AQTL/H/R 1206	AQTL/H/R 1355	AQTL/H/R 1506	AQTL/H/R 1656	AQTL/H/R 1806	AQTL/H/R 2106	AQTL/H/R 2406
K	kPa/(l/s)²	0,21	0,21	0,15	0,15	0,08	0,08	0,08
Minimum flow rate	l/s	8,6	10,0	10,8	12,2	14,1	16,5	18,7
Nominal flow rate	l/s	13,8	16,1	17,3	19,4	22,6	26,4	29,9
Maximum flow rate	l/s	23,0	26,8	28,8	32,4	37,7	44,0	49,8
Minimum pressure drop	kPa	15,8	21,4	17,9	22,6	16,2	22,1	28,2
Nominal pressure drop	kPa	40,5	54,7	45,8	57,9	41,4	56,6	72,1
Maximum pressure drop	kPa	112,4	152,0	127,2	160,8	115,0	157,2	200,4

$$\Delta P = K \cdot Q^2$$

PRESSURE DROP IN THE DESUPERHEATER*								
		AQTL/H/R 1206	AQTL/H/R 1355	AQTL/H/R 1506	AQTL/H/R 1656	AQTL/H/R 1806	AQTL/H/R 2106	AQTL/H/R 2406
K	kPa/(l/s)²	14,63	10,01	10,01	6,49	6,49	4,15	4,15
Minimum flow rate	l/s	1,1	1,3	1,4	1,6	1,8	2,1	2,3
Nominal flow rate	l/s	1,8	2,0	2,2	2,5	2,9	3,3	3,7
Maximum flow rate	l/s	2,9	3,3	3,7	4,1	4,8	5,6	6,2
Minimum pressure drop	kPa	17,9	15,7	18,9	15,7	20,8	18,1	22,5
Nominal pressure drop	kPa	45,7	40,3	48,3	40,1	53,3	46,4	57,6
Maximum pressure drop	kPa	127,0	111,9	134,2	111,3	148,2	128,9	160,0

$$\Delta P = K \cdot Q^2$$

PRESSURE DROP IN THE RECOVERY CONDENSER*								
		AQTR 1206	AQTR 1355	AQTR 1506	AQTR 1656	AQTR 1806	AQTR 2106	AQTR 2406
K	kPa/(l/s)²	0,21	0,21	0,15	0,15	0,08	0,08	0,08
Minimum flow rate	l/s	8,5	9,9	10,7	12,0	14,0	16,4	18,5
Nominal flow rate	l/s	13,7	15,9	17,1	19,3	22,4	26,2	29,6
Maximum flow rate	l/s	22,8	26,5	28,5	32,1	37,3	43,6	49,4
Minimum pressure drop	kPa	15,5	21,0	17,5	22,2	15,8	21,7	27,6
Nominal pressure drop	kPa	39,6	53,7	44,8	56,7	40,5	55,6	70,8
Maximum pressure drop	kPa	110,1	149,3	124,4	157,6	112,6	154,3	196,6

$$\Delta P = K \cdot Q^2$$

* data refer to BLN version

8.2 Technical data

AQTL BLN		1206	1355	1506	1656	1806	2106	2406
Power supply	V/ph/Hz	400 (± 10%) / 3 / 50						
Number of refrigerant circuits		2	2	2	2	2	2	2
Total capacity steps	%	17-33-50- 67-83- 100	19-37-56- 78-100	17-33-50- 67-83- 100	15-30-45- 64-82- 100	17-33-50- 67-83- 100	15-30-45- 64-82- 100	17-33-50- 67-83- 100

Refrigerant

Type		R410A						
Charge (1)	kg	35+35	35+37	37+37	37+47	47+47	54+69	69+69

Compressor

Type		Scroll						
Number		6	5	6	6	6	6	6
Start-up type		Direct						
N° of loading stages		0/100	0/100	0/100	0/100	0/100	0/100	0/100

Evaporator

Type		Plate						
Number		1	1	1	1	1	1	1
Water flow rate	l/s	13,8	16,1	17,3	19,4	22,6	26,4	29,9
Pressure drop	kPa	40,5	54,7	45,8	57,9	41,4	56,6	72,1
Water volume	l	25	25	28	28	38	38	40

Hydraulic connections

Type		Threaded gas male						
Inlet diameter	inch	4"	4"	4"	4"	4"	4"	4"
Outlet diameter	inch	4"	4"	4"	4"	4"	4"	4"

Air cooled condenser

Type		Al/Cu (standard version), Copper fins, Blue fins, Fin guard silver treatment						
------	--	--	--	--	--	--	--	--

Weight

Shipping weight	kg	3157	3201	3388	3567	3784	4503	4676
Operating weight	kg	3182	3226	3416	3595	3822	4541	4714

Additional weight

HSE*/HPF** versions	kg	0	0	0	0	0	0	0
Desuperheater versions	kg	0	0	0	0	0	0	0
With pump/s	kg	420	420	420	420	420	468	468
With pump/s and tank 750 lt	kg	1200	1200	1200	1200	1200	1580	1580
Copper Fins	kg	489	489	489	581	674	897	1034

Dimensions

Length	mm	4000	4000	4000	4000	4000	6000	6000
Width	mm	2200	2200	2200	2200	2200	2200	2200
Height	mm	2550	2550	2550	2550	2550	2550	2550

(1) Indicative value. Always refer to the value specified on the unit's label

(*) HSE Units with high efficiency brushless fans

(**) HPF Units with high static pressure fans

AQTL LN		1206	1355	1506	1656	1806	2106	2406
Power supply	V/ph/Hz	400 (± 10%) / 3 / 50						
Number of refrigerant circuits		2	2	2	2	2	2	2
Total capacity steps	%	17-33-50- 67-83- 100	19-37-56- 78-100	17-33-50- 67-83- 100	15-30-45- 64-82- 100	17-33-50- 67-83- 100	15-30-45- 64-82- 100	17-33-50- 67-83- 100

Refrigerant

Type		R410A						
Charge (1)	kg	35+35	35+37	37+37	37+47	54+54	54+69	69+69

Compressor

Type		Scroll						
Number		6	5	6	6	6	6	6
Start-up type		Direct						
N° of loading stages		0/100	0/100	0/100	0/100	0/100	0/100	0/100

Evaporator

Type		Plate						
Number		1	1	1	1	1	1	1
Water flow rate	l/s	13,3	15,5	16,7	18,8	21,8	25,5	28,8
Pressure drop	kPa	37,7	50,9	42,6	54,0	38,5	52,6	66,9
Water volume	l	25	25	28	28	38	38	40

Hydraulic connections

Type		Threaded gas male						
Inlet diameter	inch	4"	4"	4"	4"	4"	4"	4"
Outlet diameter	inch	4"	4"	4"	4"	4"	4"	4"

Air cooled condenser

Type		Al/Cu (standard version), Copper fins, Blue fins, Fin guard silver treatment						
------	--	--	--	--	--	--	--	--

Weight

Shipping weight	kg	3157	3201	3388	3567	4271	4503	4676
Operating weight	kg	3182	3226	3416	3595	4309	4541	4714

Additional weight

HSE* versions	kg	0	0	0	0	0	0	0
Desuperheater versions	kg	0	0	0	0	0	0	0
With pump/s	kg	420	420	420	420	420	468	468
With pump/s and tank 750 lt	kg	1200	1200	1200	1200	1200	1580	1580
Copper Fins	kg	489	489	489	581	760	897	1034

Dimensions

Length	mm	4000	4000	4000	4000	6000	6000	6000
Width	mm	2200	2200	2200	2200	2200	2200	2200
Height	mm	2550	2550	2550	2550	2550	2550	2550

(1) Indicative value. Always refer to the value specified on the unit's label

(*) HSE Units with high efficiency brushless fans

Technical data

AQTL ELN		1206	1355	1506	1656	1806	2106	2406
Power supply	V/ph/Hz	400 (± 10%) / 3 / 50						
Number of refrigerant circuits		2	2	2	2	2	2	2
Total capacity steps	%	17-33-50- 67-83- 100	19-37-56- 78-100	17-33-50- 67-83- 100	15-30-45- 64-82- 100	17-33-50- 67-83- 100	15-30-45- 64-82- 100	17-33-50- 67-83- 100

Refrigerant

Type		R410A						
Charge (1)	kg	35+35	35+37	37+37	37+47	54+54	54+69	69+69

Compressor

Type		Scroll						
Number		6	5	6	6	6	6	6
Start-up type		Direct						
N° of loading stages		0/100	0/100	0/100	0/100	0/100	0/100	0/100

Evaporator

Type		Plate						
Number		1	1	1	1	1	1	1
Water flow rate	l/s	12,9	14,9	16,1	18,1	21,0	24,3	27,4
Pressure drop	kPa	35,1	47,3	39,7	50,2	35,8	47,9	60,4
Water volume	l	25	25	28	28	38	38	40,4

Hydraulic connections

Type		Threaded gas male						
Inlet diameter	inch	4"	4"	4"	4"	4"	4"	4"
Outlet diameter	inch	4"	4"	4"	4"	4"	4"	4"

Air cooled condenser

Type		Al/Cu (standard version), Copper fins, Blue fins, Fin guard silver treatment						
------	--	--	--	--	--	--	--	--

Weight

Shipping weight	kg	3157	3201	3388	3567	4271	4503	4676
Operating weight	kg	3182	3226	3416	3595	4309	4541	4714

Additional weight

HSE* versions	kg	0	0	0	0	0	0	0
Desuperheater versions	kg	0	0	0	0	0	0	0
With pump/s	kg	420	420	420	420	420	468	468
With pump/s and tank 750 lt	kg	1200	1200	1200	1200	1200	1580	1580
Copper Fins	kg	489	489	489	581	760	897	1034

Dimensions

Length	mm	4000	4000	4000	4000	6000	6000	6000
Width	mm	2200	2200	2200	2200	2200	2200	2200
Height	mm	2550	2550	2550	2550	2550	2550	2550

(1) Indicative value. Always refer to the value specified on the unit's label

(*) HSE Units with high efficiency brushless fans

AQLT HT		1206	1355	1506	1656	1806	2106	2406
Power supply	V/ph/Hz	400 (± 10%) / 3 / 50						
Number of refrigerant circuits		2	2	2	2	2	2	2
Total capacity steps	%	17-33-50-67-83-100	19-37-56-78-100	17-33-50-67-83-100	15-30-45-64-82-100	17-33-50-67-83-100	15-30-45-64-82-100	17-33-50-67-83-100

Refrigerant

Type		R410A						
Charge (1)	kg	35+35	35+37	37+37	37+47	47+47	54+69	69+69

Compressor

Type		Scroll						
Number		6	5	6	6	6	6	6
Start-up type		Direct						
N° of loading stages		0/100	0/100	0/100	0/100	0/100	0/100	0/100

Evaporator

Type		Plate						
Number		1	1	1	1	1	1	1
Water flow rate	l/s	14,0	16,2	17,5	19,6	22,8	26,6	30,1
Pressure drop	kPa	41,3	55,7	46,8	59,0	42,3	57,4	73,3
Water volume	l	25	25	28	28	38	38	40,4

Hydraulic connections

Type		Threaded gas male						
Inlet diameter	inch	4"	4"	4"	4"	4"	4"	4"
Outlet diameter	inch	4"	4"	4"	4"	4"	4"	4"

Air cooled condenser

Type		Al/Cu (standard version), Copper fins, Blue fins, Fin guard silver treatment						
------	--	--	--	--	--	--	--	--

Weight

Shipping weight	kg	3157	3201	3388	3567	3784	4503	4676
Operating weight	kg	3182	3226	3416	3595	3822	4541	4714

Additional weight

Desuperheater versions	kg	0	0	0	0	0	0	0
With pump/s	kg	420	420	420	420	420	468	468
With pump/s and tank 750 lt	kg	1200	1200	1200	1200	1200	1580	1580
Copper Fins	kg	489	489	489	581	674	897	1034

Dimensions

Length	mm	4000	4000	4000	4000	4000	6000	6000
Width	mm	2200	2200	2200	2200	2200	2200	2200
Height	mm	2550	2550	2550	2550	2550	2550	2550

(1) Indicative value. Always refer to the value specified on the unit's label

Technical data

AQTH BLN		1206	1355	1506	1656	1806	2106	2406
Power supply	V/ph/Hz	400 ($\pm 10\%$) / 3 / 50						
Number of refrigerant circuits		2	2	2	2	2	2	2
Total capacity steps	%	17-33-50-67-83-100	19-37-56-78-100	17-33-50-67-83-100	15-30-45-64-82-100	17-33-50-67-83-100	15-30-45-64-82-100	17-33-50-67-83-100

Refrigerant

Type		R410A						
Charge (1)	kg	37+37	37+39	39+39	40+49	49+49	56+71	71+71

Compressor

Type		Scroll						
Number		6	5	6	6	6	6	6
Start-up type		Direct						
N° of loading stages		0/100	0/100	0/100	0/100	0/100	0/100	0/100

Evaporator

Type		Plate						
Number		1	1	1	1	1	1	1
Water flow rate	l/s	13,6	15,6	16,8	18,9	21,8	24,4	27,6
Pressure drop	kPa	39,1	51,5	43,3	54,8	38,6	48,3	61,5
Water volume	l	25	25	28	28	38	38	40,4

Hydraulic connections

Type		Threaded gas male						
Inlet diameter	inch	4"	4"	4"	4"	4"	4"	4"
Outlet diameter	inch	4"	4"	4"	4"	4"	4"	4"

Air cooled condenser

Type		Al/Cu (standard version), Copper fins, Blue fins, Fin guard silver treatment						
------	--	--	--	--	--	--	--	--

Weight

Shipping weight	kg	3319	3384	3592	3772	4005	4658	4836
Operating weight	kg	3344	3409	3620	3800	4043	4696	4874

Additional weight

HSE*/HPF** versions	kg	0	0	0	0	0	0	0
Desuperheater versions	kg	0	0	0	0	0	0	0
With pump/s	kg	420	420	420	420	420	468	468
With pump/s and tank 750 lt	kg	1200	1200	1200	1200	1200	1580	1580
Copper Fins	kg	489	489	489	581	674	840	920

Dimensions

Length	mm	4000	4000	4000	4000	4000	6000	6000
Width	mm	2200	2200	2200	2200	2200	2200	2200
Height	mm	2550	2550	2550	2550	2550	2550	2550

(1) Indicative value. Always refer to the value specified on the unit's label

(*) HSE Units with high efficiency brushless fans

(**) HPF Units with high static pressure fans

Technical data

AQTH LN		1206	1355	1506	1656	1806	2106	2406
Power supply	V/ph/Hz	400 (± 10%) / 3 / 50						
Number of refrigerant circuits		2	2	2	2	2	2	2
Total capacity steps	%	17-33-50- 67-83- 100	19-37-56- 78-100	17-33-50- 67-83- 100	15-30-45- 64-82- 100	17-33-50- 67-83- 100	15-30-45- 64-82- 100	17-33-50- 67-83- 100

Refrigerant

Type		R410A						
Charge (1)	kg	37+37	37+39	39+39	40+49	56+56	56+71	71+71

Compressor

Type		Scroll						
Number		6	5	6	6	6	6	6
Start-up type		Direct						
N° of loading stages		0/100	0/100	0/100	0/100	0/100	0/100	0/100

Evaporator

Type		Plate						
Number		1	1	1	1	1	1	1
Water flow rate	l/s	13,1	15,1	16,2	18,3	21,1	22,7	25,6
Pressure drop	kPa	36,4	48,1	40,4	51,0	36,0	41,7	52,7
Water volume	l	25	25	28	28	38	38	40,4

Hydraulic connections

Type		Threaded gas male						
Inlet diameter	inch	4"	4"	4"	4"	4"	4"	4"
Outlet diameter	inch	4"	4"	4"	4"	4"	4"	4"

Air cooled condenser

Type		Al/Cu (standard version), Copper fins, Blue fins, Fin guard silver treatment						
------	--	--	--	--	--	--	--	--

Weight

Shipping weight	kg	3319	3384	3592	3772	4504	4658	4836
Operating weight	kg	3344	3409	3620	3800	4542	4696	4874

Additional weight

HSE* versions	kg	0	0	0	0	0	0	0
Desuperheater versions	kg	0	0	0	0	0	0	0
With pump/s	kg	420	420	420	420	420	468	468
With pump/s and tank 750 lt	kg	1200	1200	1200	1200	1200	1580	1580
Copper Fins	kg	489	489	489	581	760	840	920

Dimensions

Length	mm	4000	4000	4000	4000	6000	6000	6000
Width	mm	2200	2200	2200	2200	2200	2200	2200
Height	mm	2550	2550	2550	2550	2550	2550	2550

(1) Indicative value. Always refer to the value specified on the unit's label

(*) HSE Units with high efficiency brushless fans

Technical data

AQTH ELN		1206	1355	1506	1656	1806	2106	2406
Power supply	V/ph/Hz	400 ($\pm 10\%$) / 3 / 50						
Number of refrigerant circuits		2	2	2	2	2	2	2
Total capacity steps	%	17-33-50- 67-83- 100	19-37-56- 78-100	17-33-50- 67-83- 100	15-30-45- 64-82- 100	17-33-50- 67-83- 100	15-30-45- 64-82- 100	17-33-50- 67-83- 100

Refrigerant

Type		R410A						
Charge (1)	kg	37+37	37+39	39+39	40+49	56+56	56+71	71+71

Compressor

Type		Scroll						
Number		6	5	6	6	6	6	6
Start-up type		Direct						
N° of loading stages		0/100	0/100	0/100	0/100	0/100	0/100	0/100

Evaporator

Type		Plate						
Number		1	1	1	1	1	1	1
Water flow rate	l/s	12,6	14,5	15,6	17,6	20,3	22,2	24,6
Pressure drop	kPa	33,8	44,5	37,4	47,3	33,4	40,0	48,8
Water volume	l	25	25	28	28	38	38	40,4

Hydraulic connections

Type		Threaded gas male						
Inlet diameter	inch	4"	4"	4"	4"	4"	4"	4"
Outlet diameter	inch	4"	4"	4"	4"	4"	4"	4"

Air cooled condenser

Type		Al/Cu (standard version), Copper fins, Blue fins, Fin guard silver treatment						
------	--	--	--	--	--	--	--	--

Weight

Shipping weight	kg	3319	3384	3592	3772	4504	4658	4836
Operating weight	kg	3344	3409	3620	3800	4542	4696	4874

Additional weight

HSE* versions	kg	0	0	0	0	0	0	0
Desuperheater versions	kg	0	0	0	0	0	0	0
With pump/s	kg	420	420	420	420	420	468	468
With pump/s and tank 750 lt	kg	1200	1200	1200	1200	1200	1580	1580
Copper Fins	kg	489	489	489	581	760	840	920

Dimensions

Length	mm	4000	4000	4000	4000	6000	6000	6000
Width	mm	2200	2200	2200	2200	2200	2200	2200
Height	mm	2550	2550	2550	2550	2550	2550	2550

(1) Indicative value. Always refer to the value specified on the unit's label

(*) HSE Units with high efficiency brushless fans

Technical data

AQTH HT		1206	1355	1506	1656	1806	2106	2406
Power supply	V/ph/Hz	400 (± 10%) / 3 / 50						
Number of refrigerant circuits		2	2	2	2	2	2	2
Total capacity steps	%	17-33-50- 67-83- 100	19-37-56- 78-100	17-33-50- 67-83- 100	15-30-45- 64-82- 100	17-33-50- 67-83- 100	15-30-45- 64-82- 100	17-33-50- 67-83- 100

Refrigerant

Type		R410A						
Charge (1)	kg	37+37	37+39	39+39	40+49	49+49	56+71	71+71

Compressor

Type		Scroll						
Number		6	5	6	6	6	6	6
Start-up type		Direct						
N° of loading stages		0/100	0/100	0/100	0/100	0/100	0/100	0/100

Evaporator

Type		Plate						
Number		1	1	1	1	1	1	1
Water flow rate	l/s	13,7	15,6	17,0	19,1	22,1	25,9	29,3
Pressure drop	kPa	39,9	51,5	44,3	55,9	39,5	54,4	69,4
Water volume	l	25	25	28	28	38	38	40,4

Hydraulic connections

Type		Threaded gas male						
Inlet diameter	inch	4"	4"	4"	4"	4"	4"	4"
Outlet diameter	inch	4"	4"	4"	4"	4"	4"	4"

Air cooled condenser

Type		Al/Cu (standard version), Copper fins, Blue fins, Fin guard silver treatment						
------	--	--	--	--	--	--	--	--

Weight

Shipping weight	kg	3319	3384	3592	3772	4005	4658	4836
Operating weight	kg	3344	3409	3620	3800	4043	4696	4874

Additional weight

Desuperheater versions	kg	0	0	0	0	0	0	0
With pump/s	kg	420	420	420	420	420	468	468
With pump/s and tank 750 lt	kg	1200	1200	1200	1200	1200	1580	1580
Copper Fins	kg	489	489	489	581	674	840	920

Dimensions

Length	mm	4000	4000	4000	4000	4000	6000	6000
Width	mm	2200	2200	2200	2200	2200	2200	2200
Height	mm	2550	2550	2550	2550	2550	2550	2550

(1) Indicative value. Always refer to the value specified on the unit's label

Technical data

AQTC BLN/LN/ELN/HT		1206	1355	1506	1656	1806	2106	2406
Power supply	V/ph/Hz	400 (± 10%) / 3 / 50						
Number of refrigerant circuits		2	2	2	2	2	2	2
Total capacity steps	%	17-33-50-67-83-100	19-37-56-78-100	17-33-50-67-83-100	15-30-45-64-82-100	17-33-50-67-83-100	15-30-45-64-82-100	17-33-50-67-83-100

Refrigerant

Type		R410A
------	--	-------

Compressor

Type		Scroll						
Number		6	5	6	6	6	6	6
Start-up type		Direct						
N° of loading stages		0/100	0/100	0/101	0/102	0/103 (BLN/HT) 0/104 (LN/ELN)	0/100	0/100

Air cooled condenser

Type		Al/Cu (standard version), Copper fins, Blue fins, Fin guard silver treatment
------	--	--

Refrigerant connections

Inlet diameter	inch	1 1/8"	1 1/8"	1 1/8"	1 3/8"	1 3/8"	1 1/8"	1 1/8"
Outlet diameter	inch	2 1/8"	2 1/8"	2 1/8"	2 1/8" - 2 5/8"	2 5/8"	2 1/8"	2 1/8"

Weight

Shipping weight	kg	2974	3012	3182	3350	3515	4187	4360
						4014 (LN/ELN)		

Additional weight

HSE*/HPF** versions	kg	0	0	0	0	0	0	0
Copper Fins	kg	489	489	489	581	674 (BLN/HT)	897	1034
						760 (LN/ELN)		

Dimensions

Length	mm	4000	4000	4000	4000	4000 (BLN/HT)	6000	6000
						6000 (LN/ELN)		
Width	mm	2200	2200	2200	2200	2200	2200	2200
Height	mm	2550	2550	2550	2550	2550	2550	2550

(*) HSE Units with high efficiency brushless fans

(**) HPF Units with high static pressure fans

Technical data

AQTR BLN/LN/ELN/HT		1206	1355	1506	1656	1806	2106	2406
Power supply	V/ph/Hz	400 (± 10%) / 3 / 50						
Number of refrigerant circuits		2	2	2	2	2	2	2
Total capacity steps	%	17-33-50-67-83-100	19-37-56-78-100	17-33-50-67-83-100	15-30-45-64-82-100	17-33-50-67-83-100	15-30-45-64-82-100	17-33-50-67-83-100

Refrigerant

Type	R410A
------	-------

Compressor

Type	Scroll							
Number	6	5	6	6	6	6	6	6
Start-up type	Direct							
N° of loading stages	0/100	0/100	0/100	0/100	0/100	0/100	0/100	0/100

Evaporator

Type	Plate							
Number	1	1	1	1	1	1	1	1
Water flow rate	l/s	13,7	15,9	17,1	19,3	22,4	26,2	29,6
Pressure drop	kPa	39,7	53,7	44,8	56,7	40,5	55,6	70,8
Water volume	l	25	25	28	28	38	38	40,4

Hydraulic connections

Type	Threaded gas male							
Inlet diameter	inch	4"	4"	4"	4"	4"	4"	4"
Outlet diameter	inch	4"	4"	4"	4"	4"	4"	4"

Recovery condenser

Type	Plate							
Number	1	1	1	1	1	1	1	1
Water flow rate	l/s	13,7	15,9	17,1	19,3	22,4	26,2	29,6
Pressure drop	kPa	39,6	53,7	44,8	56,7	40,5	55,6	70,8
Water volume	l	25	25	28	28	38	38	40,4

Hydraulic connections

Type	Threaded gas male							
Inlet diameter	inch	4"	4"	4"	4"	4"	4"	4"
Outlet diameter	inch	4"	4"	4"	4"	4"	4"	4"

Air cooled condenser

Type	Al/Cu (standard version), Copper fins, Blue fins, Fin guard silver treatment							
------	--	--	--	--	--	--	--	--

Weight

Shipping weight	kg	3435	3500	3719	3898	4174 (BLN)	4807	5036
						4627 (LN-ELN)		
Operating weight	kg	3485	3550	3775	3954	4250 (BLN)	4883	5112
						4703 (LN-ELN)		

Additional weight

HSE*/HPF** versions	kg	0	0	0	0	0	0	0
Copper Fins	kg	489	489	489	581	674 (BLN-HT)	897	1034
						760 (LN-ELN)		

Dimensions

Length	mm	4000	4000	4000	4000	4000 (BLN)	6000	6000
						6000 (LN-ELN)		
Width	mm	2200	2200	2200	2200	2200	2200	2200
Height	mm	2550	2550	2550	2550	2550	2550	2550

(*) HSE Units with high efficiency brushless fans

(**) HPF Units with high static pressure fans

8.3 Unit Electrical Data

AQTL/AQTH/AQTC/AQTR BLN		1206	1355	1506	1656	1806	2106	2406(**)
Rated voltage	V/ph/Hz	400 (± 10%) / 3 / 50						
Max. absorbed power	kW	150	134	191	209	227	265	298/302
Max. current FLA	A	321	302	413	459	504	476	530/538
Max. start-up current LRA	A	485	497	608	700	745	788	842/850
External fuses	A	315	315	400	400	500	500	630
Max. cable section (*)	mm ²	185	185	2x150	2x150	2x185	2x185	2x185

Exchanger resistance

Rated voltage	V/ph/Hz	230 (± 10%) / 1 / 50						
Max. absorbed power	W	370						

AQTL/AQTH/AQTC/AQTR LN/ELN		1206	1355	1506	1656	1806	2106	2406(**)
Rated voltage	V/ph/Hz	400 (± 10%) / 3 / 50						
Max. absorbed power	kW	147	131	187	204	222	259	292/294
Max. current FLA	A	315	294	403	447	492	462	514/518
Max. start-up current LRA	A	479	489	598	688	733	774	826/830
External fuses	A	315	315	400	400	500	500	630
Max. cable section (*)	mm ²	185	185	2x150	2x150	2x185	2x185	2x185

Exchanger resistance

Rated voltage	V/ph/Hz	230 (± 10%) / 1 / 50						
Max. absorbed power	W	370						

AQTL/AQTH/AQTC/AQTR HSE BLN/LN/ELN/HT / HPF		1206	1355	1506	1656	1806	2106	2406(**)
Rated voltage	V/ph/Hz	400 (± 10%) / 3 / 50						
Max. absorbed power	kW	153	139	196	215	234	272	307/312
Max. current FLA	A	322	304	415	461	507	479	533/541
Max. start-up current LRA	A	486	499	610	702	748	791	845/853
External fuses	A	315	315	400	400	500	500	630
Max. cable section (*)	mm ²	185	185	2x150	2x150	2x185	2x185	2x185

Exchanger resistance

Rated voltage	V/ph/Hz	230 (± 10%) / 1 / 50						
Max. absorbed power	W	370						

(*) The dimensioning of the unit's power cables is the responsibility of the installer, who shall consider: the rating, the maximum working temperature in the room, the type of insulation and the cable laying, the maximum length of the power supply line.

(**) The second data for size 2406 refers to AQTH.

Compressors Electrical Data

AQTL/AQTH/AQTC/AQTR		1206	1355	1506	1656	1806	2106	2406
Number	-	6	5	6	6	6	6	6
Max. absorbed power	kW	circuit 1 - (23,8+23,8+23,8) circuit 2 - (23,8+23,8+23,8)	circuit 1 - (23,8+23,8+23,8) circuit 2 - (30+30)	circuit 1 - (30+30+30) circuit 2 - (30+30+30)	circuit 1 - (30+30+30) circuit 2 - (35,4+35,4+35,4)	circuit 1 - (35,4+35,4+35,4) circuit 2 - (35,4+35,4+35,4)	circuit 1 - (36,1+36,1+36,1) circuit 2 - (46,7+46,7+46,7)	circuit 1 - (46,7+46,7+46,7) circuit 2 - (46,7+46,7+46,7)
Max. current FLA	A	circuit 1 - (51+51+51) circuit 2 - (51+51+51)	circuit 1 - (51+51+51) circuit 2 - (65+65)	circuit 1 - (65+65+65) circuit 2 - (65+65+65)	circuit 1 - (65+65+65) circuit 2 - (79+79+79)	circuit 1 - (79+79+79) circuit 2 - (79+79+79)	circuit 1 - (65,4+65,4+65,4) circuit 2 - (82+82+82)	circuit 1 - (82+82+82) circuit 2 - (82+82+82)
Oil pan resistor	W	circuit 1 - (150+150+150) circuit 2 - (150+150+150)	circuit 1 - (150+150+150) circuit 2 - (150+150+150)	circuit 1 - (150+150+150) circuit 2 - (150+150+150)	circuit 1 - (150+150+150) circuit 2 - (150+150+150)	circuit 1 - (150+150+150) circuit 2 - (150+150+150)	circuit 1 - (150+150+150) circuit 2 - (150+150+150)	circuit 1 - (150+150+150) circuit 2 - (150+150+150)

Fans Electrical Data

AQTL/AQTH/AQTC/AQTR BLN		1206	1355	1506	1656	1806	2106	2406
Rated voltage	V/ph/Hz	400 (± 10%) / 3 / 50						
Number	-	4	5	6	7	8	9	10-12*
Rated power	kW	1,80	1,80	1,80	1,80	1,80	1,80	1,80
Absorbed rated current FLA	A	3,8	3,8	3,8	3,8	3,8	3,8	3,8

AQTL/AQTH/AQTC/AQTR LN/ELN		1206	1355	1506	1656	1806	2106	2406
Rated voltage	V/ph/Hz	400 (± 10%) / 3 / 50						
Number	-	4	5	6	7	8	9	10-12*
Rated power	kW	1,15	1,15	1,15	1,15	1,15	1,15	1,15
Absorbed rated current FLA	A	2,2	2,2	2,2	2,2	2,2	2,2	2,2

AQTL/AQTH/AQTC/AQTR HSE BLN/LN/ELN/HT/HPF		1206	1355	1506	1656	1806	2106	2406
Rated voltage	V/ph/Hz	400 (± 10%) / 3 / 50						
Number	-	4	5	6	7	8	9	10-12*
Rated power	kW	2,67	2,67	2,67	2,67	2,67	2,67	2,67
Absorbed rated current FLA	A	4,1	4,1	4,1	4,1	4,1	4,1	4,1

* The second data refers to AQTH

Pumps electrical data

AQTL/AQTH 1/2P-SP		1206	1355	1506	1656	1806	2106	2406
Rated voltage	V/ph/Hz	400 (± 10%) / 3 / 50						
Rated power	kW	5,5	5,5	5,5	7,5	7,5	11	11
Absorbed rated current FLA	A	10,1	10,1	10,1	13,7	13,7	20	20

AQTL/AQTH 1/2P-HP		1206	1355	1506	1656	1806	2106	2406
Rated voltage	V/ph/Hz	400 (± 10%) / 3 / 50						
Rated power	kW	7,5	7,5	7,5	11	11	15	15
Absorbed rated current FLA	A	13,7	13,7	13,7	20	20	26,7	26,7

8.4 Hydraulic Features

AQTL/AQTH Unit

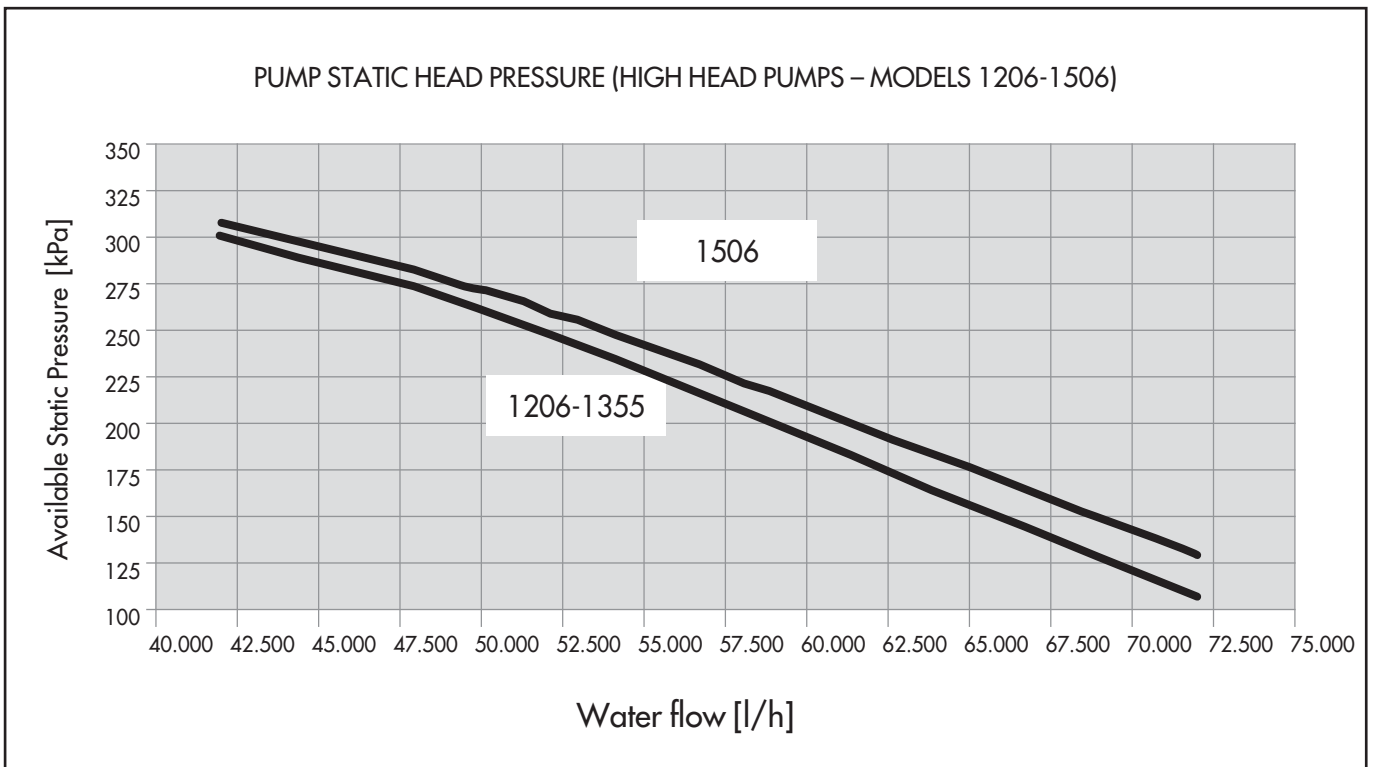
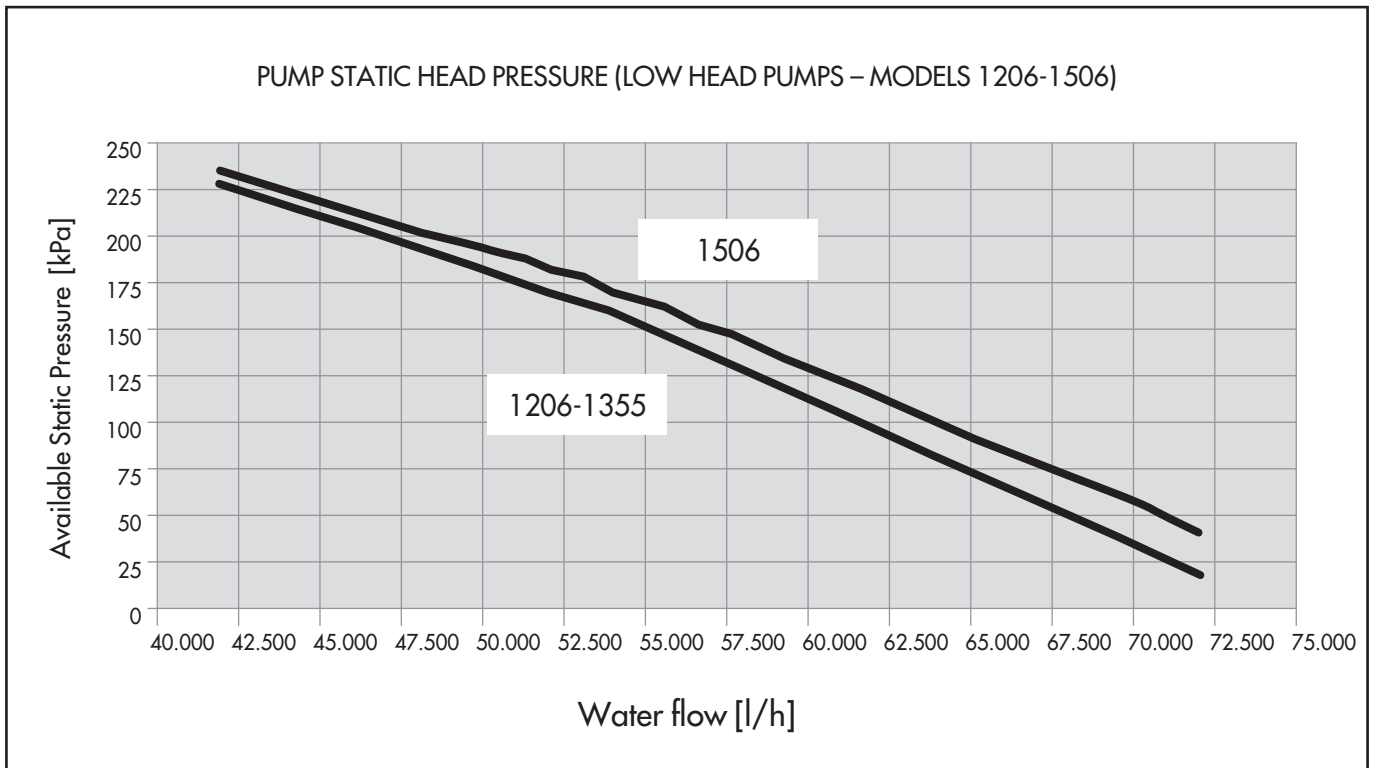

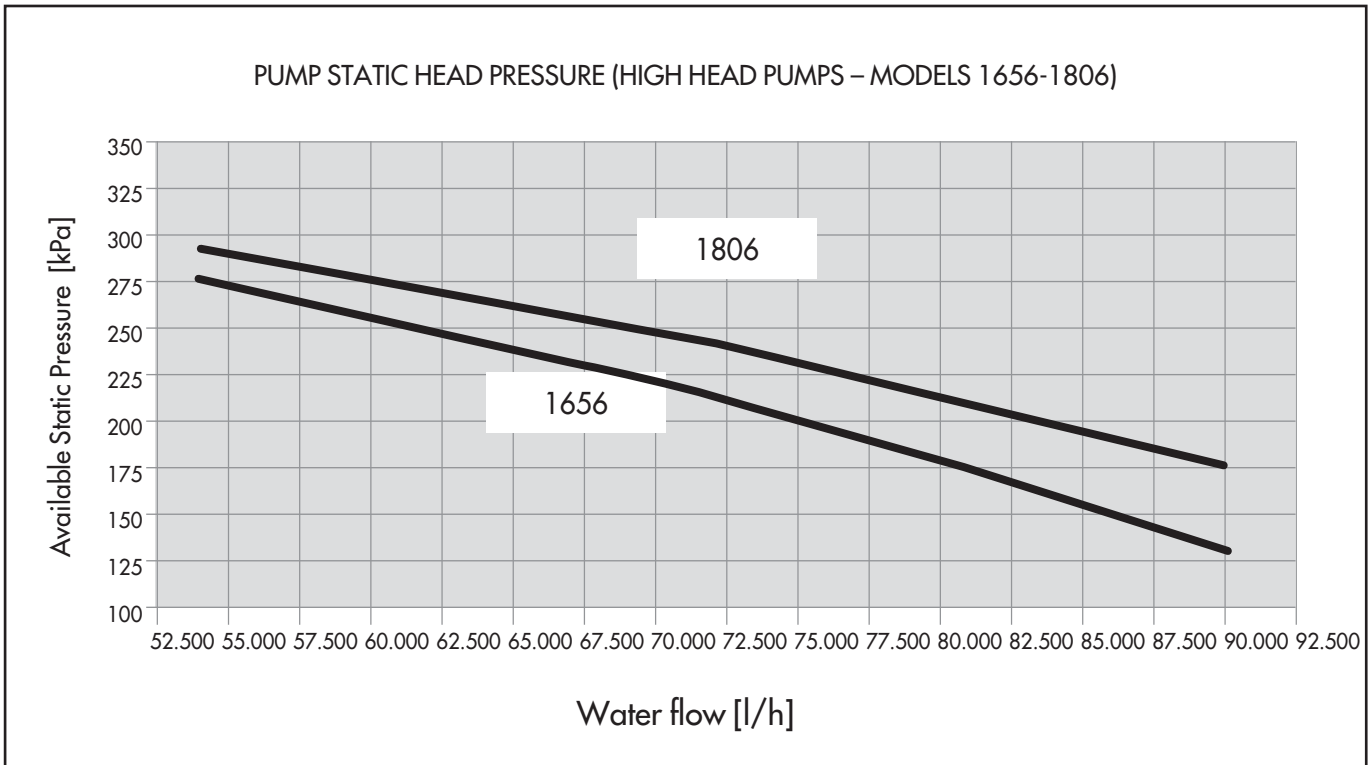
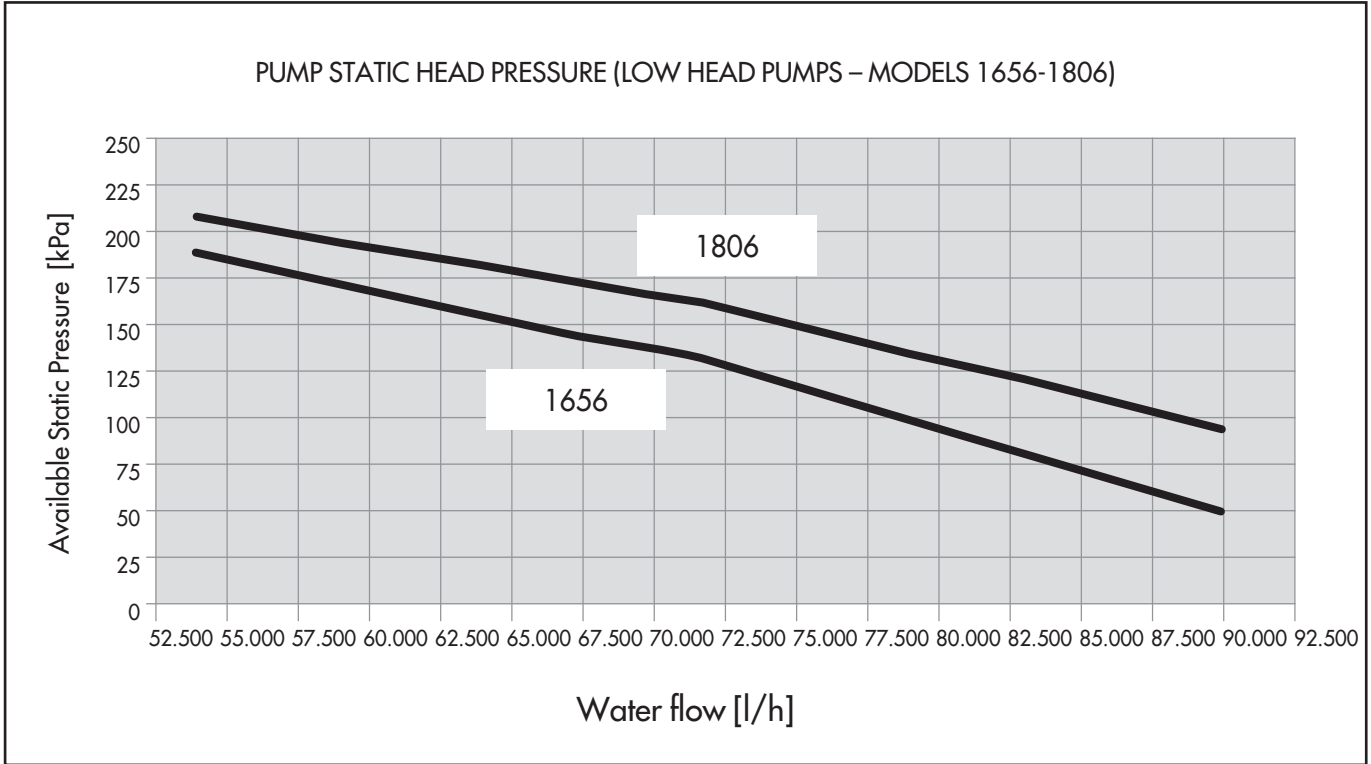

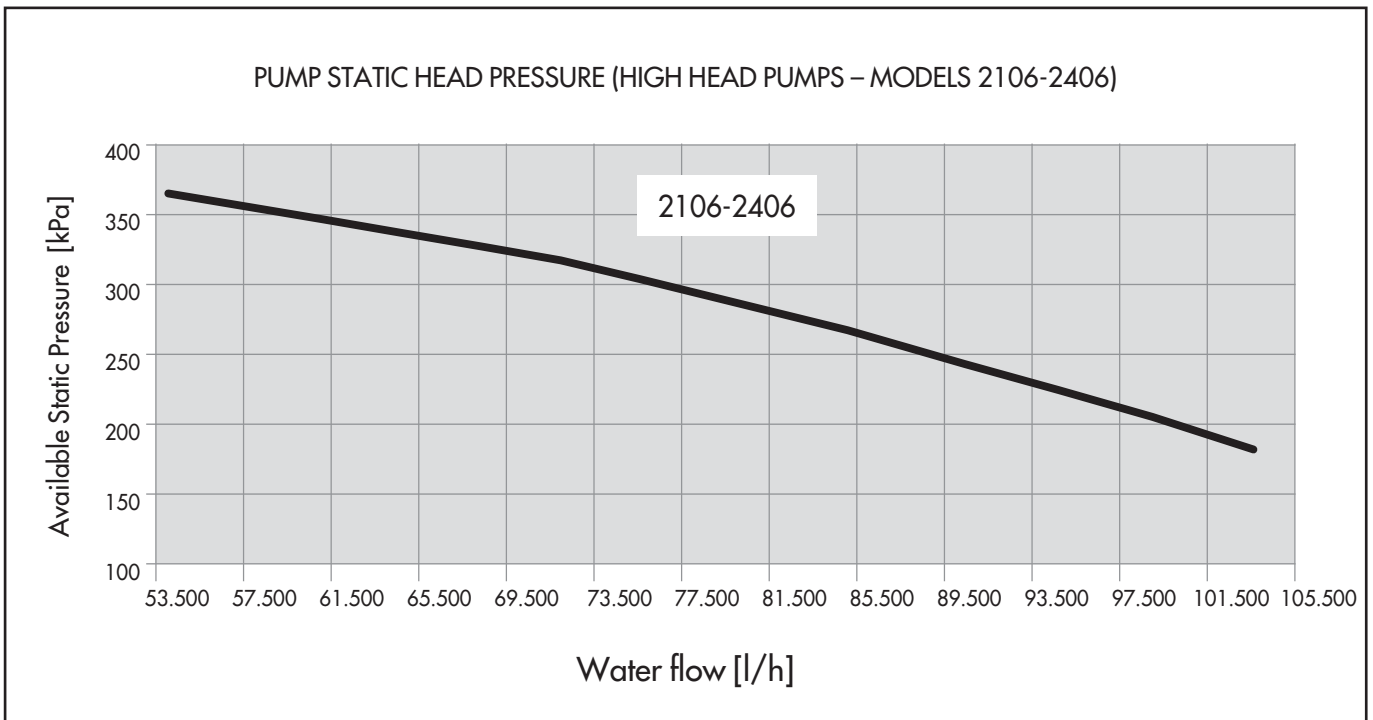
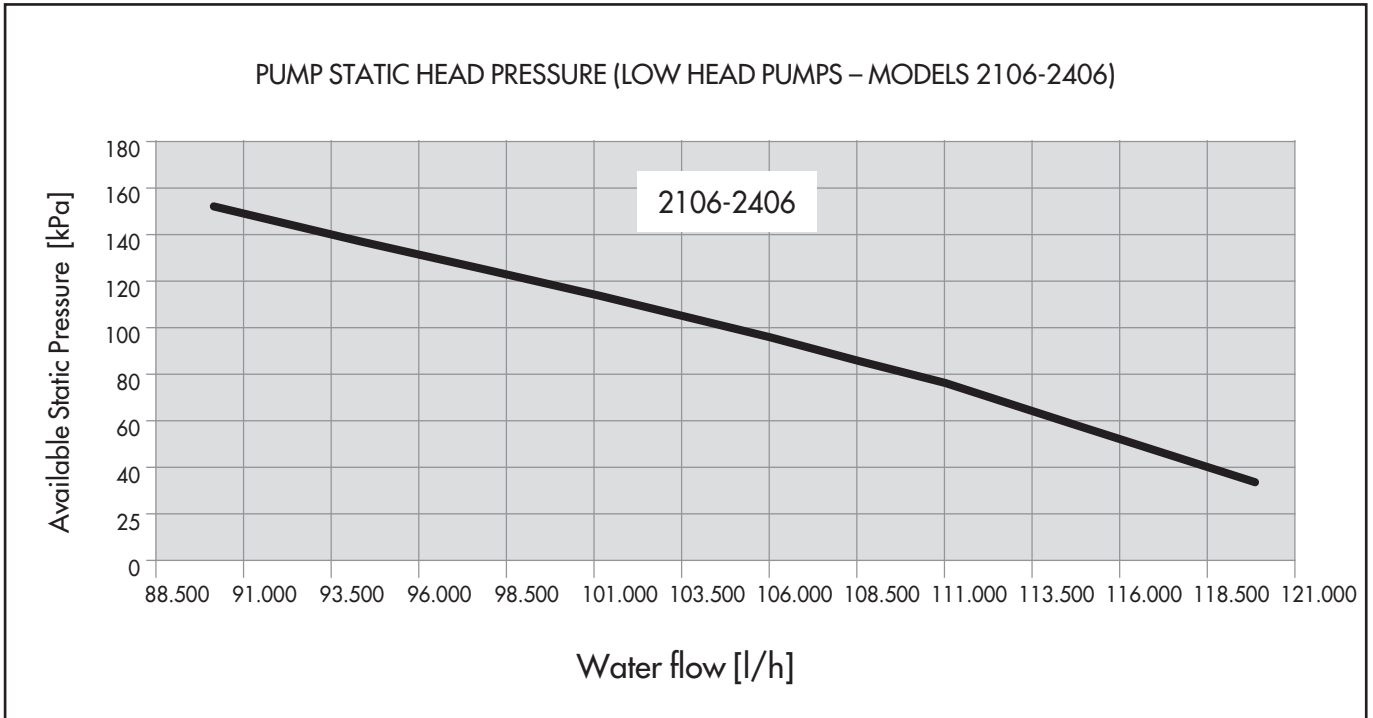

8.5 Position of shock adsorbers and weight distribution on supports

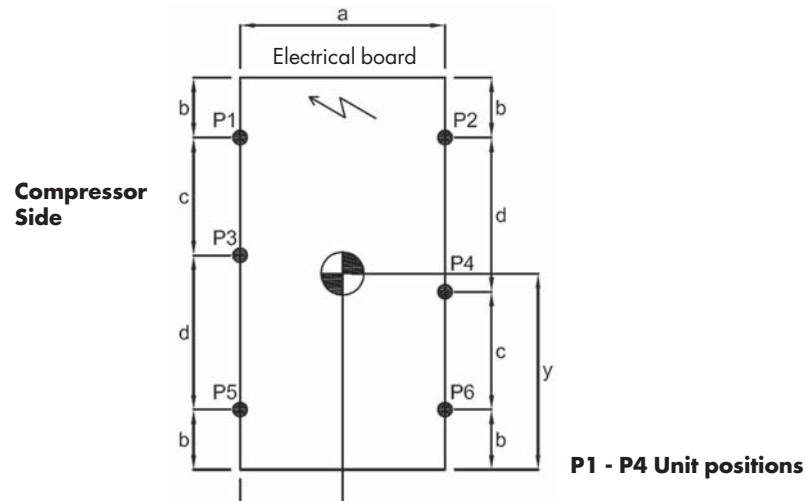

AQTL 1206 - 1806 Al/Cu All STD Versions

AQTL Al/Cu	Weight distribution						Operating weight	Shipping weight	P1-P6 coordinates*				CG coordinates	
	F1	F2	F3	F4	F5	F6			a	b	c	d	x	y
	kg	kg	kg	kg	kg	kg	kg	kg	mm	mm	mm	mm	mm	mm
1206	735	535	644	416	526	326	3182	3157	2099	613	1208	1583	886	2207
1355	722	514	652	423	561	353	3226	3201	2099	613	1208	1583	883	2163
1506	782	555	696	443	583	356	3416	3388	2099	613	1208	1583	875	2187
1656	836	593	736	462	605	362	3595	3567	2099	613	1208	1583	870	2204
1806	884	649	772	502	626	390	3822	3784	2099	613	1208	1583	889	2213
1206 1P	758	599	656	465	522	363	3362	3337	2099	613	1208	1583	934	2217
1355 1P	745	578	664	472	558	391	3406	3381	2099	613	1208	1583	930	2175
1506 1P	805	619	708	491	580	394	3596	3568	2099	613	1208	1583	921	2197
1656 1P	859	656	748	510	602	399	3775	3747	2099	613	1208	1583	914	2213
1806 1P	907	712	784	551	622	427	4002	3964	2099	613	1208	1583	929	2220
1206 2P	738	644	659	541	557	463	3602	3577	2099	613	1208	1583	1003	2157
1355 2P	725	623	668	548	592	490	3646	3621	2099	613	1208	1583	999	2118
1506 2P	785	664	711	567	615	493	3836	3808	2099	613	1208	1583	987	2142
1656 2P	839	702	752	587	637	499	4015	3987	2099	613	1208	1583	977	2159
1806 2P	887	757	787	627	657	527	4242	4204	2099	613	1208	1583	989	2169
1206 1PT	602	607	695	729	816	822	4272	3497	2099	613	1208	1583	1104	1869
1355 1PT	589	587	703	736	852	849	4316	3541	2099	613	1208	1583	1099	1839
1506 1PT	650	628	747	755	874	852	4506	3728	2099	613	1208	1583	1084	1871
1656 1PT	704	665	787	775	896	858	4685	3907	2099	613	1208	1583	1073	1896
1806 1PT	751	721	823	815	916	886	4912	4124	2099	613	1208	1583	1078	1917
1206 2PT	589	615	700	761	846	872	4382	3607	2099	613	1208	1583	1120	1844
1355 2PT	576	594	708	767	881	900	4426	3651	2099	613	1208	1583	1115	1815
1506 2PT	636	635	752	787	904	903	4616	3838	2099	613	1208	1583	1100	1847
1656 2PT	690	673	792	806	926	908	4795	4017	2099	613	1208	1583	1088	1873
1806 2PT	738	728	828	846	946	936	5022	4234	2099	613	1208	1583	1092	1894

* Dimensions are referred to unit with antivibration mounted isolators.

Technical data

AQTL 1206 - 1806 Cu/Cu All STD Versions

AQTL Cu/Cu	Weight distribution						Operating weight	Shipping weight	P1-P6 coordinates*				CG coordinates	
	F1	F2	F3	F4	F5	F6			a	b	c	d	x	y
	kg	kg	kg	kg	kg	kg	kg	kg	mm	mm	mm	mm	mm	mm
1206	826	620	745	513	638	431	3774	3749	2099	613	1208	1583	913	2161
1355	815	600	754	521	675	460	3825	3800	2099	613	1208	1583	910	2124
1506	877	642	800	541	699	464	4023	3995	2099	613	1208	1583	903	2146
1656	944	692	855	576	738	487	4292	4264	2099	613	1208	1583	901	2157
1806	1008	763	909	633	778	534	4626	4588	2099	613	1208	1583	919	2160
1206 1P	849	683	756	562	635	469	3954	3929	2099	613	1208	1583	953	2171
1355 1P	838	664	766	569	672	497	4005	3980	2099	613	1208	1583	950	2136
1506 1P	900	706	811	590	695	501	4203	4175	2099	613	1208	1583	940	2156
1656 1P	967	756	866	624	734	524	4472	4444	2099	613	1208	1583	937	2166
1806 1P	1031	827	920	682	775	571	4806	4768	2099	613	1208	1583	951	2169
1206 2P	829	729	760	638	669	568	4194	4169	2099	613	1208	1583	1011	2123
1355 2P	818	709	770	645	706	597	4245	4220	2099	613	1208	1583	1008	2089
1506 2P	880	751	815	666	730	601	4443	4415	2099	613	1208	1583	996	2111
1656 2P	947	801	870	700	769	623	4712	4684	2099	613	1208	1583	990	2123
1806 2P	1011	872	924	758	810	671	5046	5008	2099	613	1208	1583	1000	2128
1206 1PT	694	692	796	826	929	927	4864	4089	2099	613	1208	1583	1098	1874
1355 1PT	682	672	805	833	966	956	4915	4140	2099	613	1208	1583	1094	1848
1506 1PT	744	715	850	854	990	960	5113	4335	2099	613	1208	1583	1081	1876
1656 1PT	811	765	906	888	1029	983	5382	4604	2099	613	1208	1583	1071	1898
1806 1PT	876	836	959	946	1069	1030	5716	4928	2099	613	1208	1583	1075	1916
1206 2PT	680	700	801	857	958	978	4974	4199	2099	613	1208	1583	1113	1852
1355 2PT	669	680	810	865	995	1006	5025	4250	2099	613	1208	1583	1108	1827
1506 2PT	731	722	855	885	1019	1010	5223	4445	2099	613	1208	1583	1095	1855
1656 2PT	798	772	911	920	1058	1033	5492	4714	2099	613	1208	1583	1084	1878
1806 2PT	862	843	965	977	1099	1080	5826	5038	2099	613	1208	1583	1088	1897

AQTH 1206 - 1806 Al/Cu All STD Versions

AQTH Al/Cu	Weight distribution						Operating weight	Shipping weight	P1-P6 coordinates*				CG coordinates	
	F1	F2	F3	F4	F5	F6			a	b	c	d	x	y
	kg	kg	kg	kg	kg	kg	kg	kg	mm	mm	mm	mm	mm	mm
1206	766	557	676	439	558	349	3344	3319	2099	613	1208	1583	887	2197
1355	757	539	688	449	597	380	3409	3384	2099	613	1208	1583	885	2154
1506	821	583	736	471	624	386	3620	3592	2099	613	1208	1583	878	2176
1656	875	620	776	491	646	391	3800	3772	2099	613	1208	1583	873	2193
1806	926	678	815	533	669	422	4043	4005	2099	613	1208	1583	891	2201
1206 1P	788	621	687	488	554	386	3524	3499	2099	613	1208	1583	933	2207
1355 1P	780	603	699	497	594	417	3589	3564	2099	613	1208	1583	930	2166
1506 1P	844	647	747	520	620	423	3800	3772	2099	613	1208	1583	921	2186
1656 1P	898	684	787	539	642	428	3980	3952	2099	613	1208	1583	914	2202
1806 1P	949	742	826	581	666	459	4223	4185	2099	613	1208	1583	929	2209
1206 2P	769	666	691	564	589	486	3764	3739	2099	613	1208	1583	1000	2150
1355 2P	760	648	703	573	629	517	3829	3804	2099	613	1208	1583	996	2112
1506 2P	824	692	751	596	655	523	4040	4012	2099	613	1208	1583	984	2135
1656 2P	878	729	791	615	677	528	4220	4192	2099	613	1208	1583	975	2151
1806 2P	929	787	830	658	701	559	4463	4425	2099	613	1208	1583	985	2161
1206 1PT	633	629	726	752	848	845	4434	3659	2099	613	1208	1583	1097	1874
1355 1PT	624	611	738	761	888	876	4499	3724	2099	613	1208	1583	1092	1846
1506 1PT	688	656	786	784	914	882	4710	3932	2099	613	1208	1583	1077	1877
1656 1PT	742	693	827	803	937	887	4890	4112	2099	613	1208	1583	1066	1900
1806 1PT	793	751	866	846	960	918	5133	4345	2099	613	1208	1583	1071	1920
1206 2PT	619	637	731	783	878	895	4544	3769	2099	613	1208	1583	1112	1850
1355 2PT	611	619	743	793	918	926	4609	3834	2099	613	1208	1583	1108	1823
1506 2PT	675	663	791	816	944	932	4820	4042	2099	613	1208	1583	1093	1854
1656 2PT	729	700	832	835	966	937	5000	4222	2099	613	1208	1583	1081	1878
1806 2PT	780	758	871	877	990	968	5243	4455	2099	613	1208	1583	1085	1899

* Dimensions are referred to unit with antivibration mounted isolators.

AQTH 1206 - 1806 Cu/Cu All STD Versions

AQTH Cu/Cu	Weight distribution						Operating weight	Shipping weight	P1-P6 coordinates*				CG coordinates	
	F1	F2	F3	F4	F5	F6			a	b	c	d	x	y
	kg	kg	kg	kg	kg	kg	kg	kg	mm	mm	mm	mm	mm	mm
1206	838	628	756	521	650	440	3833	3808	2099	613	1208	1583	913	2159
1355	829	610	768	531	689	471	3898	3873	2099	613	1208	1583	911	2122
1506	893	654	816	554	716	477	4110	4082	2099	613	1208	1583	904	2143
1656	961	705	872	588	755	500	4381	4353	2099	613	1208	1583	902	2153
1806	1025	776	926	646	796	547	4717	4679	2099	613	1208	1583	920	2157
1206 1P	860	692	768	570	646	477	4013	3988	2099	613	1208	1583	952	2169
1355 1P	852	674	780	580	686	508	4078	4053	2099	613	1208	1583	950	2133
1506 1P	916	718	828	602	712	514	4290	4262	2099	613	1208	1583	941	2153
1656 1P	984	769	883	637	752	537	4561	4533	2099	613	1208	1583	937	2163
1806 1P	1048	840	937	695	792	584	4897	4859	2099	613	1208	1583	951	2166
1206 2P	841	737	771	646	681	577	4253	4228	2099	613	1208	1583	1010	2121
1355 2P	832	719	784	656	721	608	4318	4293	2099	613	1208	1583	1007	2088
1506 2P	896	763	831	678	747	614	4530	4502	2099	613	1208	1583	995	2109
1656 2P	964	814	887	713	787	637	4801	4773	2099	613	1208	1583	989	2120
1806 2P	1028	885	941	771	827	684	5137	5099	2099	613	1208	1583	999	2126
1206 1PT	705	700	807	834	940	936	4923	4148	2099	613	1208	1583	1096	1876
1355 1PT	696	683	819	844	980	967	4988	4213	2099	613	1208	1583	1092	1851
1506 1PT	760	727	867	866	1006	973	5200	4422	2099	613	1208	1583	1079	1878
1656 1PT	828	777	922	901	1046	996	5471	4693	2099	613	1208	1583	1069	1900
1806 1PT	892	849	977	959	1087	1043	5807	5019	2099	613	1208	1583	1074	1918
1206 2PT	691	708	812	866	970	986	5033	4258	2099	613	1208	1583	1110	1854
1355 2PT	683	690	824	875	1010	1017	5098	4323	2099	613	1208	1583	1106	1830
1506 2PT	747	734	872	898	1036	1023	5310	4532	2099	613	1208	1583	1093	1858
1656 2PT	815	785	928	933	1076	1046	5581	4803	2099	613	1208	1583	1082	1880
1806 2PT	879	856	982	991	1116	1093	5917	5129	2099	613	1208	1583	1086	1898

AQTC 1206 - 1806 Al/Cu All STD Versions

AQTC Al/Cu	Weight distribution						Operating weight	Shipping weight	P1-P6 coordinates*				CG coordinates	
	F1	F2	F3	F4	F5	F6			a	b	c	d	x	y
	kg	kg	kg	kg	kg	kg	kg	kg	mm	mm	mm	mm	mm	mm
1206	684	447	624	368	545	308	2.974	2.974	2.099	613	1.208	1.583	835	2.157
1355	670	425	631	373	579	334	3.012	3.012	2.099	613	1.208	1.583	832	2.110
1506	725	458	672	388	603	335	3.182	3.182	2.099	613	1.208	1.583	822	2.135
1656	778	494	711	406	623	339	3.350	3.350	2.099	613	1.208	1.583	819	2.156
1806	809	519	741	430	653	363	3.515	3.515	2.099	613	1.208	1.583	827	2.151

AQTC 1206 - 1806 Cu/Cu All STD Versions

AQTC Cu/Cu	Weight distribution						Operating weight	Shipping weight	P1-P6 coordinates*				CG coordinates	
	F1	F2	F3	F4	F5	F6			a	b	c	d	x	y
	kg	kg	kg	kg	kg	kg	kg	kg	mm	mm	mm	mm	mm	mm
1206	756	517	705	450	638	398	3.463	3.463	2.099	613	1.208	1.583	870	2.120
1355	742	495	712	455	672	425	3.501	3.501	2.099	613	1.208	1.583	867	2.080
1506	798	528	754	470	696	426	3.671	3.671	2.099	613	1.208	1.583	857	2.103
1656	864	577	808	503	733	446	3.932	3.932	2.099	613	1.208	1.583	858	2.118
1806	909	615	853	543	781	488	4.189	4.189	2.099	613	1.208	1.583	868	2.110

* Dimensions are referred to unit with antivibration mounted isolators.

Technical data

AQTR 1206 - 1806 Al/Cu All STD Versions

AQTR Al/Cu	Weight distribution						Operating weight	Shipping weight	P1-P6 coordinates*				CG coordinates	
	F1	F2	F3	F4	F5	F6			a	b	c	d	x	y
	kg	kg	kg	kg	kg	kg	kg	kg	mm	mm	mm	mm	mm	mm
1206	792	616	685	476	545	369	3485	3435	2099	613	1208	1583	923	2220
1355	783	598	698	486	585	400	3550	3500	2099	613	1208	1583	920	2178
1506	850	648	746	512	610	408	3775	3719	2099	613	1208	1583	915	2200
1656	904	685	787	531	633	414	3954	3898	2099	613	1208	1583	908	2214
1806	965	765	829	587	651	452	4250	4174	2099	613	1208	1583	934	2227

AQTR 1206 - 1806 Cu/Cu All STD Versions

AQTR Cu/Cu	Weight distribution						Operating weight	Shipping weight	P1-P6 coordinates*				CG coordinates	
	F1	F2	F3	F4	F5	F6			a	b	c	d	x	y
	kg	kg	kg	kg	kg	kg	kg	kg	mm	mm	mm	mm	mm	mm
1206	894	719	771	558	609	435	3986	3936	2099	613	1208	1583	945	2220
1355	857	671	780	570	679	493	4052	4002	2099	613	1208	1583	942	2143
1506	924	721	829	596	704	501	4276	4220	2099	613	1208	1583	936	2164
1656	992	771	885	631	744	524	4547	4491	2099	613	1208	1583	932	2173
1806	1066	865	942	703	780	579	4936	4860	2099	613	1208	1583	956	2181

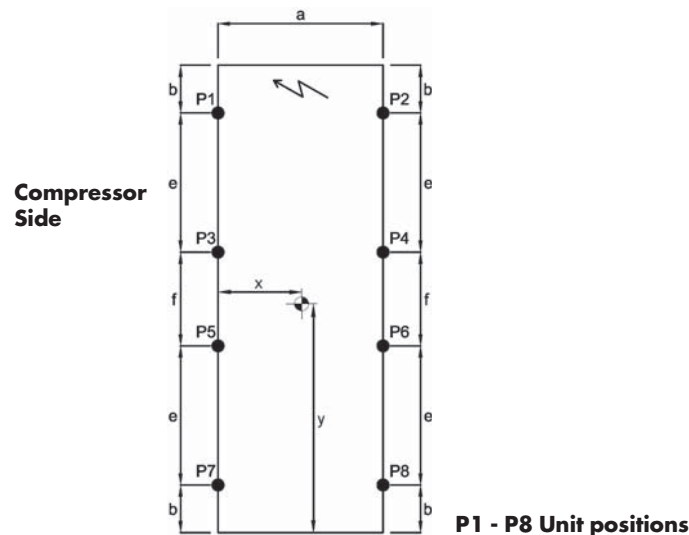

P1 - P8 Unit positions

AQTL/AQTH/AQTC/AQTR 1806 Al/Cu (LN and ELN)

1806 LN/ELN	Weight distribution								Operating weight	Shipping weight	P1-P8 coordinates*				CG coordinates	
	F1	F2	F3	F4	F5	F6	F7	F8			a	b	e	f	x	y
	kg	kg	kg	kg	kg	kg	kg	kg	kg	kg	mm	mm	mm	mm	mm	mm
AQTL	899	694	701	496	584	379	386	181	4321	4283	2099	577	1882	1116	893	3617
AQTL1P	931	756	714	539	586	411	370	194	4501	4463	2099	577	1882	1116	929	3648
AQTL2P	938	901	750	713	639	602	452	415	4741	4703	2099	577	1882	1116	982	3543
AQTL1PT	902	777	711	587	599	474	408	283	5411	4623	2099	577	1882	1116	1064	3469
AQTL2PT	942	922	755	735	645	625	458	438	5521	4733	2099	577	1882	1116	1077	3457
AQTH	999	695	785	481	658	354	444	140	4554	4516	2099	577	1882	1116	812	3634
AQTH1P	1031	756	798	523	660	385	427	153	4734	4696	2099	577	1882	1116	849	3662
AQTH2P	1002	778	795	571	672	448	466	242	4974	4936	2099	577	1882	1116	904	3561
AQTH1PT	1038	902	834	698	713	577	509	373	5644	4856	2099	577	1882	1116	991	3488
AQTH2PT	1042	923	839	720	719	600	516	397	5754	4966	2099	577	1882	1116	1006	3477
AQTR	1035	766	796	527	655	386	416	147	4728	4652	2099	577	1882	1116	853	3680
AQTC	831	592	669	430	573	334	412	173	4014	4014	2099	577	1882	1116	843	3543

* Dimensions are referred to unit with antivibration mounted isolators.

AQTL/AQTH/AQTC/AQTR 1806 Cu/Cu (LN and ELN)

1806 LN/ELN	Weight distribution								Operating weight	Shipping weight	P1-P8 coordinates*				CG coordinates	
	F1	F2	F3	F4	F5	F6	F7	F8			a	b	e	f	x	y
	kg	kg	kg	kg	kg	kg	kg	kg	kg	kg	mm	mm	mm	mm	mm	mm
AQTL	984	779	794	589	681	476	491	286	5081	5043	2099	577	1882	1116	923	3505
AQTL1P	1016	840	807	632	683	508	475	299	5261	5223	2099	577	1882	1116	953	3536
AQTL2P	1023	986	843	806	737	700	557	520	5501	5463	2099	577	1882	1116	997	3450
AQTL1PT	987	862	804	679	696	571	513	388	6171	5383	2099	577	1882	1116	1067	3395
AQTL2PT	1027	1007	848	828	742	722	564	544	6281	5493	2099	577	1882	1116	1079	3386
AQTH	1084	780	877	573	755	451	549	245	5314	5276	2099	577	1882	1116	852	3524
AQTH1P	1116	841	891	616	757	483	532	258	5494	5456	2099	577	1882	1116	883	3553
AQTH2P	1087	863	888	664	770	546	571	347	5734	5696	2099	577	1882	1116	929	3470
AQTH1PT	1123	986	927	791	810	674	614	478	6404	5616	2099	577	1882	1116	1003	3415
AQTH2PT	1126	1007	932	812	816	697	621	502	6514	5726	2099	577	1882	1116	1016	3406
AQTR	1120	851	889	620	752	483	521	252	5488	5412	2099	577	1882	1116	886	3568
AQTC	915	676	762	523	671	432	517	278	4774	4774	2099	577	1882	1116	882	3436

AQTL 2106-2406 Al/Cu All STD Version

AQTL	Weight distribution								Operating weight	Shipping weight	P1-P8 coordinates*				CG coordinates	
	F1	F2	F3	F4	F5	F6	F7	F8			a	b	e	f	x	y
	kg	kg	kg	kg	kg	kg	kg	kg	kg	kg	mm	mm	mm	mm	mm	mm
2106	934	723	733	522	614	403	412	202	4543	4505	2099	577	1882	1116	898	3597
2406	953	744	755	546	637	428	439	229	4731	4693	2099	577	1882	1116	907	3566
2106 1P	941	762	742	563	624	445	425	245	4747	4709	2099	577	1882	1116	934	3566
2406 1P	961	783	764	586	647	470	451	273	4935	4897	2099	577	1882	1116	941	3538
2106 2P	951	812	754	615	637	499	441	302	5011	4973	2099	577	1882	1116	976	3530
2406 2P	970	833	776	639	661	524	467	330	5199	5161	2099	577	1882	1116	982	3505
2106 1PT	1004	1014	802	812	682	691	479	489	5973	4935	2099	577	1882	1116	1099	3459
2406 1PT	1024	1035	824	835	705	717	505	517	6161	5123	2099	577	1882	1116	1100	3439
2106 2PT	1024	1057	812	845	686	719	474	507	6123	5085	2099	577	1882	1116	1115	3469
2406 2PT	911	941	728	758	619	649	436	467	6311	5273	2099	577	1882	1116	1116	3450

AQTL 2106-2406 Cu/Cu All STD Version

AQTL	Weight distribution								Operating weight	Shipping weight	P1-P8 coordinates*				CG coordinates	
	F1	F2	F3	F4	F5	F6	F7	F8			a	b	e	f	x	y
	kg	kg	kg	kg	kg	kg	kg	kg	kg	kg	mm	mm	mm	mm	mm	mm
2106	1023	808	837	622	726	512	541	326	5395	5357	2099	577	1882	1116	926	3466
2406	1064	855	878	669	767	558	581	372	5745	5707	2099	577	1882	1116	940	3439
2106 1P	1059	878	852	671	729	548	522	341	5599	5561	2099	577	1882	1116	957	3500
2406 1P	1100	925	893	717	770	594	562	387	5949	5911	2099	577	1882	1116	969	3472
2106 2P	1026	901	848	723	743	618	565	440	5863	5825	2099	577	1882	1116	1003	3411
2406 2P	1067	948	889	770	783	664	605	486	6213	6175	2099	577	1882	1116	1012	3389
2106 1PT	1093	1099	906	912	795	801	607	613	6825	6037	2099	577	1882	1116	1096	3373
2406 1PT	1134	1146	947	958	835	847	648	659	7175	6387	2099	577	1882	1116	1099	3356
2106 2PT	1113	1142	916	945	799	828	602	631	6975	6187	2099	577	1882	1116	1110	3383
2406 2PT	1154	1189	957	992	840	875	642	677	7325	6537	2099	577	1882	1116	1112	3366

* Dimensions are referred to unit with antivibration mounted isolators.

Technical data

AQTH 2106-2406 Al/Cu All STD Version

AQTH	Weight distribution								Operating weight	Shipping weight	P1-P8 coordinates*				CG coordinates	
	F1	F2	F3	F4	F5	F6	F7	F8			a	b	e	f	x	y
	kg	kg	kg	kg	kg	kg	kg	kg	kg	kg	mm	mm	mm	mm	mm	mm
2106	1021	707	808	495	683	369	470	156	4709	4671	2099	577	1882	1116	813	3608
2406	1046	737	831	522	703	395	489	180	4903	4865	2099	577	1882	1116	828	3591
2106 1P	1057	777	823	543	685	405	452	171	4913	4875	2099	577	1882	1116	853	3640
2406 1P	1082	807	846	571	706	431	470	195	5107	5069	2099	577	1882	1116	867	3623
2106 2P	1011	800	812	601	694	483	494	283	5177	5333	2099	577	1882	1116	921	3520
2406 2P	1049	830	842	623	720	501	513	294	5371	5333	2099	577	1882	1116	921	3520
2106 1PT	1079	986	865	772	738	645	524	431	6040	5002	2099	577	1882	1116	1028	3479
2406 1PT	1116	1028	900	812	771	684	555	467	6333	5295	2099	577	1882	1116	1034	3462
2106 2PT	1111	1041	887	817	755	685	532	462	6289	5251	2099	577	1882	1116	1046	3480
2406 2PT	1136	1071	910	845	776	711	550	485	6483	5445	2099	577	1882	1116	1051	3471

AQTH 2106-2406 Cu/Cu All STD Version

AQTH	Weight distribution								Operating weight	Shipping weight	P1-P8 coordinates*				CG coordinates	
	F1	F2	F3	F4	F5	F6	F7	F8			a	b	e	f	x	y
	kg	kg	kg	kg	kg	kg	kg	kg	kg	kg	mm	mm	mm	mm	mm	mm
2106	1115	801	911	597	790	476	587	273	5549	5511	2099	577	1882	1116	855	3496
2406	1148	840	943	635	821	513	616	307	5823	5785	2099	577	1882	1116	870	3477
2106 1P	1151	870	926	646	793	512	568	288	5753	5715	2099	577	1882	1116	888	3528
2406 1P	1184	910	958	683	824	549	597	322	6027	5989	2099	577	1882	1116	901	3508
2106 2P	1118	893	922	698	806	582	611	387	6017	5979	2099	577	1882	1116	936	3440
2406 2P	1152	933	954	735	837	618	640	421	6291	6253	2099	577	1882	1116	946	3425
2106 1PT	1185	1092	980	887	858	765	653	560	6979	6191	2099	577	1882	1116	1036	3399
2406 1PT	1219	1131	1012	924	889	801	683	595	7253	6465	2099	577	1882	1116	1042	3387
2106 2PT	1204	1134	990	920	863	792	648	578	7129	6341	2099	577	1882	1116	1051	3408
2406 2PT	1238	1174	1022	957	894	829	677	613	7403	6615	2099	577	1882	1116	1056	3397

* Dimensions are referred to unit with antivibration mounted isolators.

AQTC 2106-2406 Al/Cu All STD Version

AQTC	Weight distribution								Operating weight	Shipping weight	P1-P8 coordinates*				CG coordinates	
	F1	F2	F3	F4	F5	F6	F7	F8			a	b	e	f	x	y
	kg	kg	kg	kg	kg	kg	kg	kg	kg	kg	mm	mm	mm	mm	mm	mm
2106	856	609	694	448	599	352	438	191	4187	4187	2099	577	1882	1116	846	3520
2406	873	628	714	470	620	376	462	217	4360	4360	2099	577	1882	1116	857	3492

AQTC 2106-2406 Cu/Cu All STD Version

AQTC	Weight distribution								Operating weight	Shipping weight	P1-P8 coordinates*				CG coordinates	
	F1	F2	F3	F4	F5	F6	F7	F8			a	b	e	f	x	y
	kg	kg	kg	kg	kg	kg	kg	kg	kg	kg	mm	mm	mm	mm	mm	mm
2106	956	709	804	557	714	467	562	315	5084	5084	2099	577	1882	1116	889	3405
2406	956	715	806	564	716	475	566	324	5122	5122	2099	577	1882	1116	894	3399

AQTR 2106-2406 Al/Cu All STD Version

AQTR	Weight distribution								Operating weight	Shipping weight	P1-P8 coordinates*				CG coordinates	
	F1	F2	F3	F4	F5	F6	F7	F8			a	b	e	f	x	y
	kg	kg	kg	kg	kg	kg	kg	kg	kg	kg	mm	mm	mm	mm	mm	mm
2106	1056	775	821	540	681	400	446	165	4883	4807	2099	577	1882	1116	851	3649
2406	1087	815	846	575	703	432	463	191	5112	5036	2099	577	1882	1116	870	3635

AQTR 2106-2406 Cu/Cu All STD Version

AQTR	Weight distribution								Operating weight	Shipping weight	P1-P8 coordinates*				CG coordinates	
	F1	F2	F3	F4	F5	F6	F7	F8			a	b	e	f	x	y
	kg	kg	kg	kg	kg	kg	kg	kg	kg	kg	mm	mm	mm	mm	mm	mm
2106	1156	875	930	649	796	515	570	289	5780	5704	2099	577	1882	1116	888	3528
2406	1202	931	972	701	836	564	606	334	6146	6070	2099	577	1882	1116	907	3506

* Dimensions are referred to unit with antivibration mounted isolators.

8.6 Overall dimensions

AQTL/AQTH 1206-1806

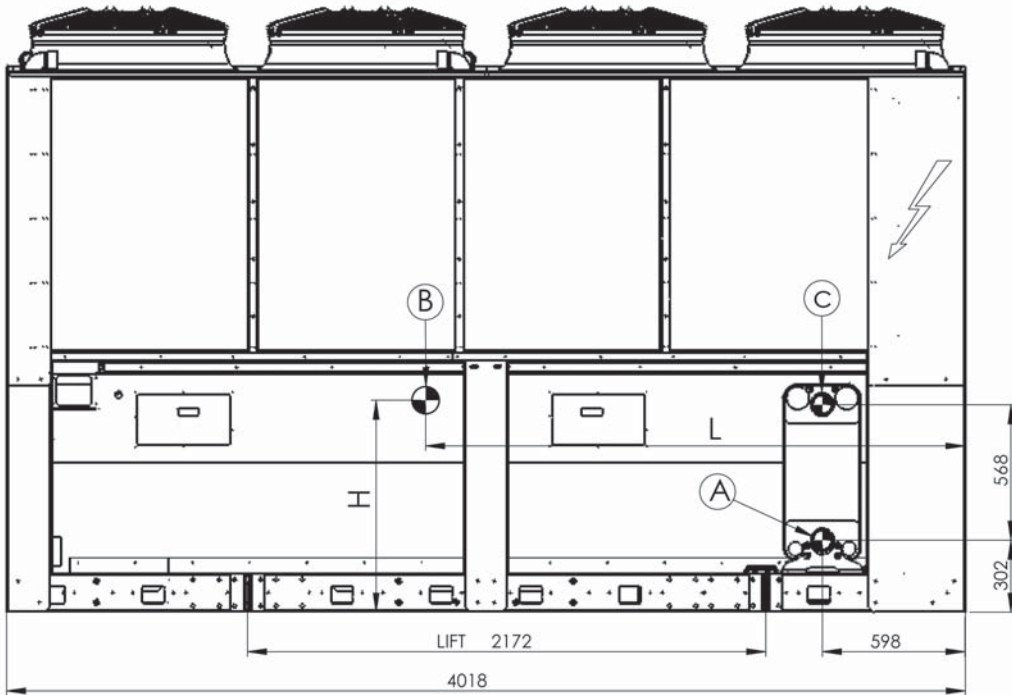

1806

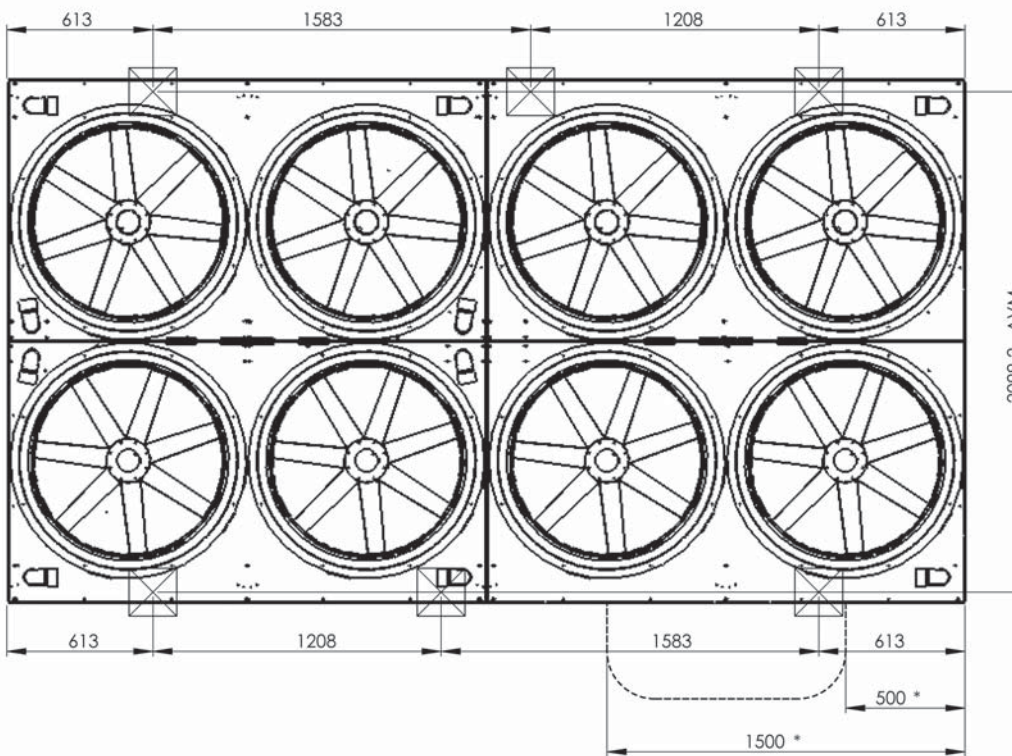

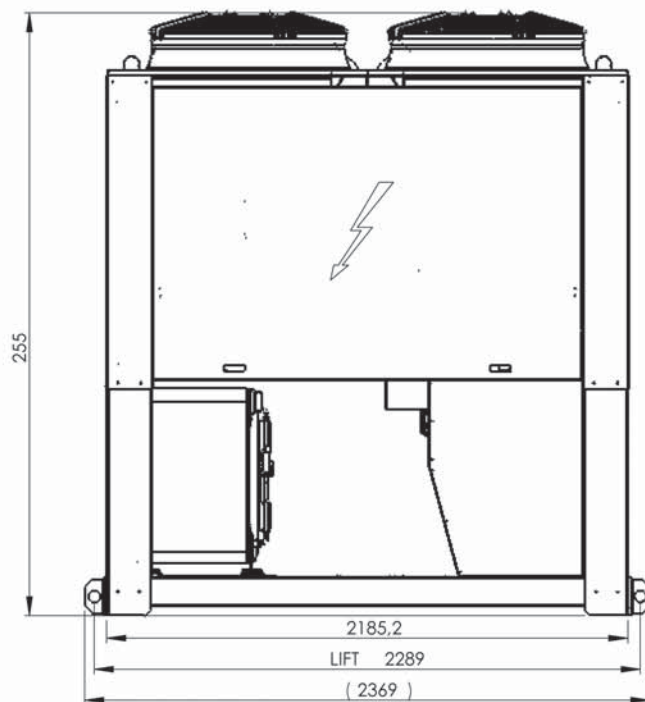
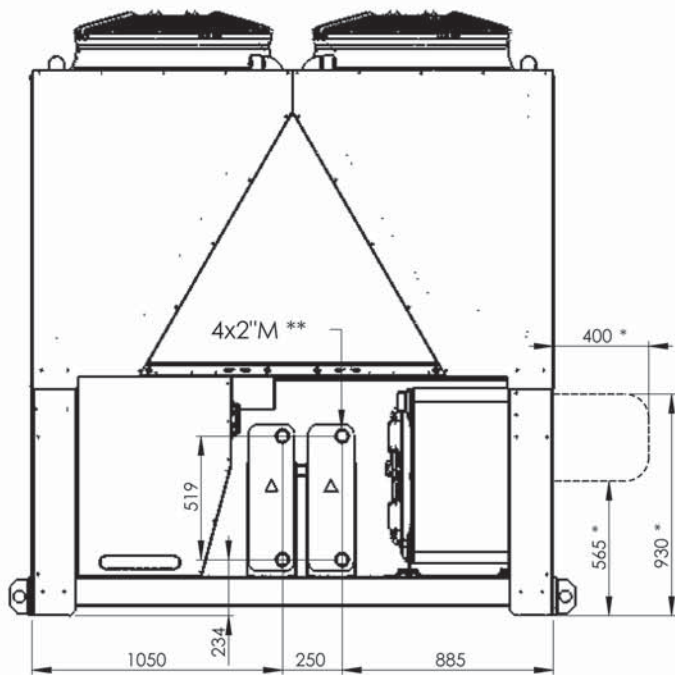

1656

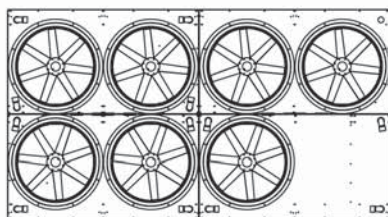

1506

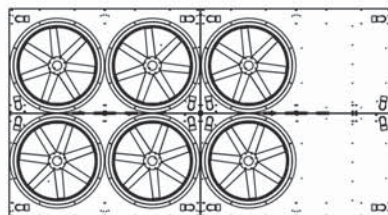

1355

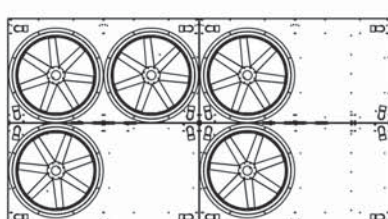

1206

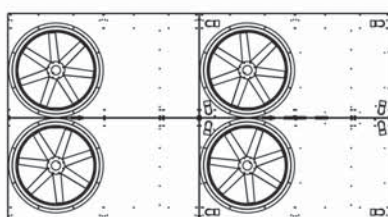

(*) Only with hydro pumps
(**) Only for desuperheater

WATER CONNECTION STANDARD		
Water outlet "A"	4"	
Water inlet "C"	4"	
WATER CONNECTION HYDRO OPTION		
	H	L
1P-LP	889	2260
1P-HP		
2P-LP	343	2238
2P-HP		
750 L TANK	414	1377
Water inlet "B"	4"M	

AQTL/AQTH 1806 ELN AQTL/AQTH 2106-2406

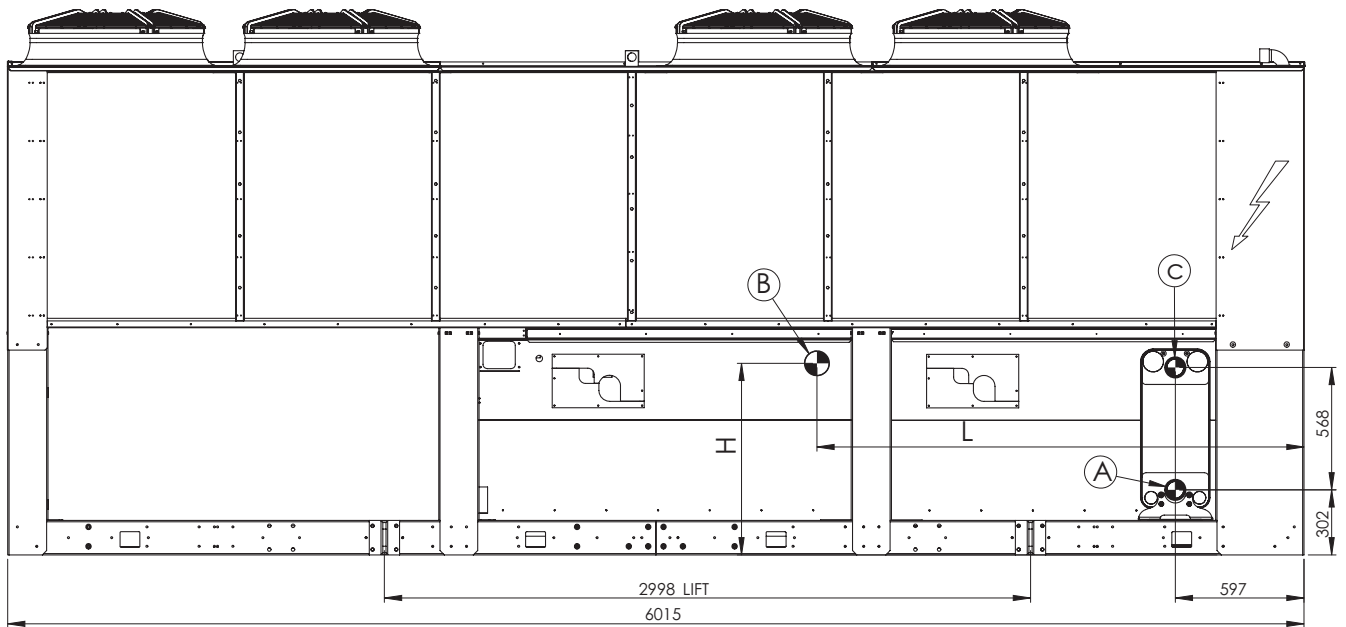

1806 ELN

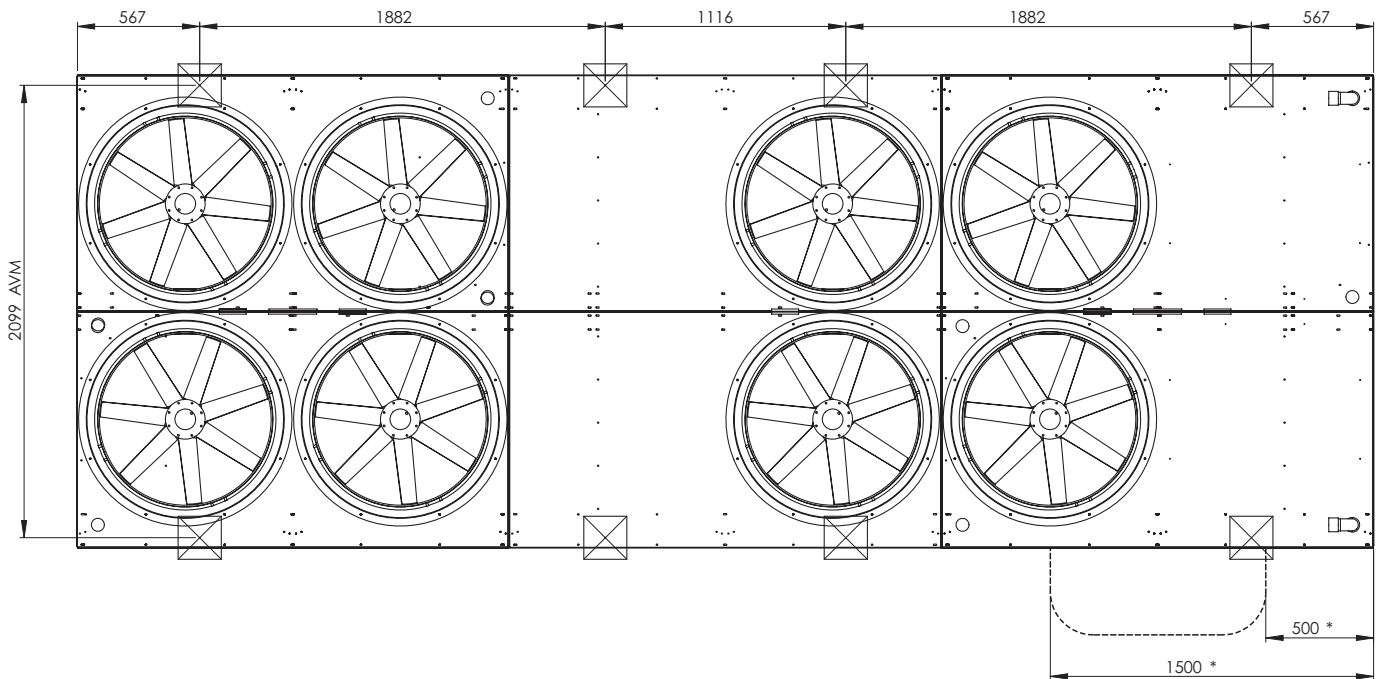

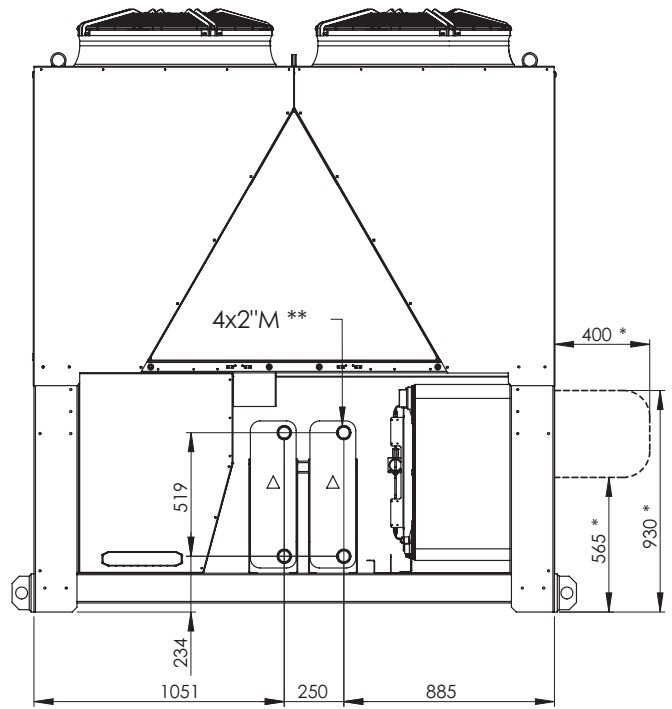
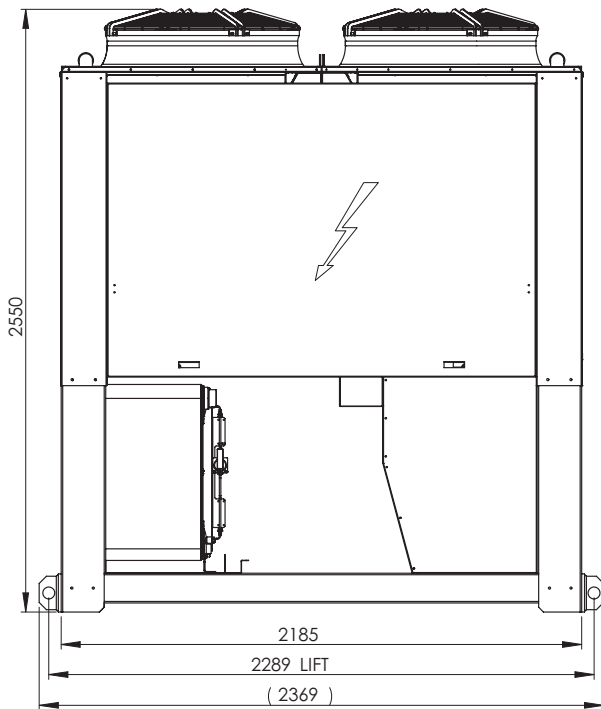

2106

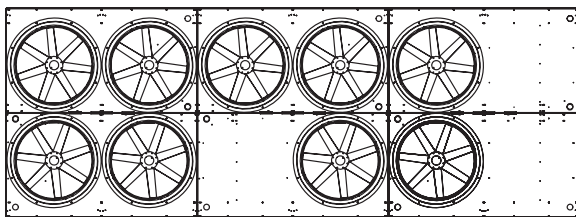

2406
AQTL

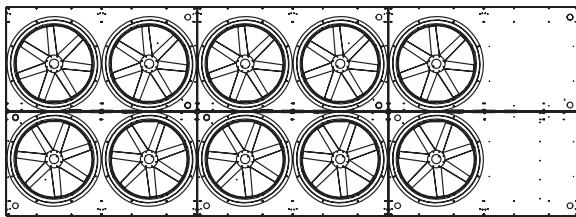

2406
AQTH

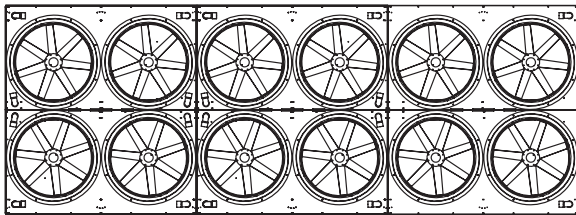

WATER CONNECTION STANDARD		
Water outlet "A"	4"	
Water inlet "C"	4"	
WATER CONNECTION HYDRO OPTION		
	H	L
1P-LP	889	2260
1P-HP		
2P-LP	343	2238
2P-HP		
750 L TANK	414	1377
Water inlet "B"	4"M	

AQTC 1206-1806

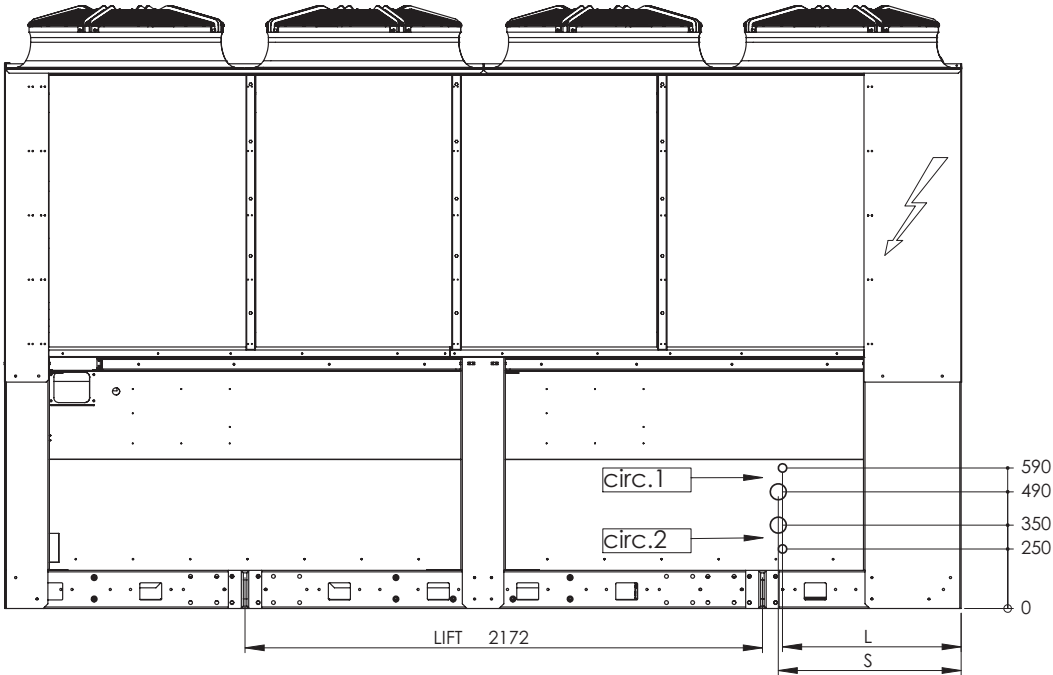

1806

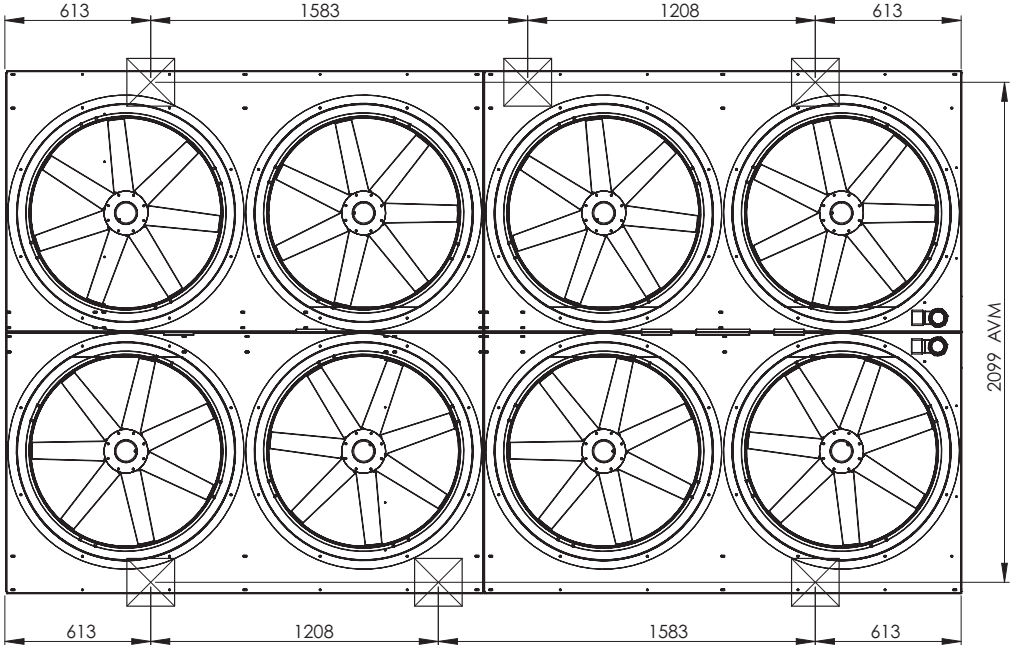

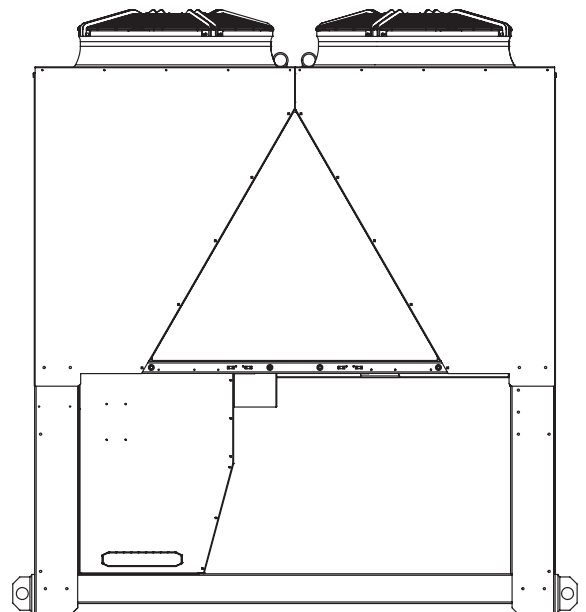
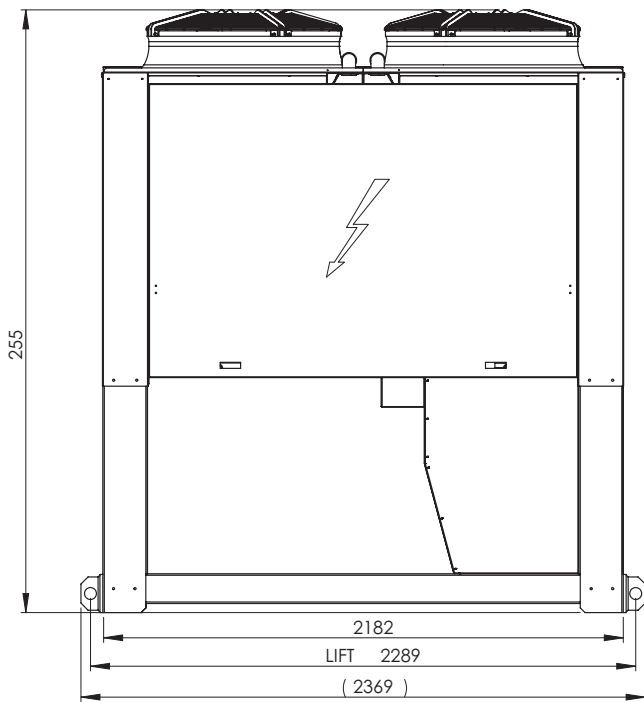

1656

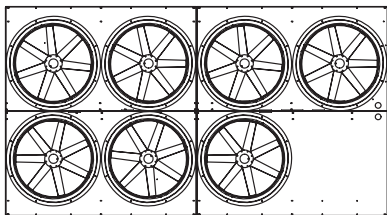

1506

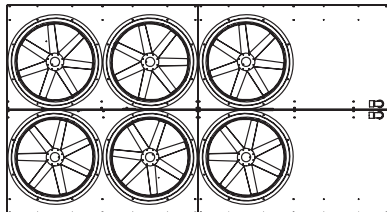

1355

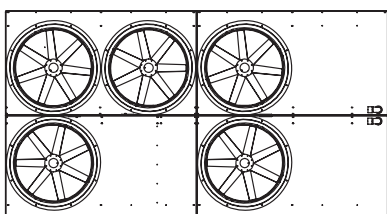

1206

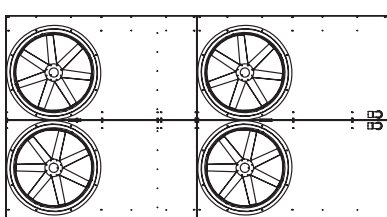

REFRIGERANT CONNECTION				
	Liquid line		Suction line	
	L (mm)	Ø	S (mm)	Ø
1206-1506	735	1"1/8	735	2"1/8
1656-1806	750	1"3/8	750	2"5/8

Technical data

AQTC 1806 ELN AQTC 2106-2406

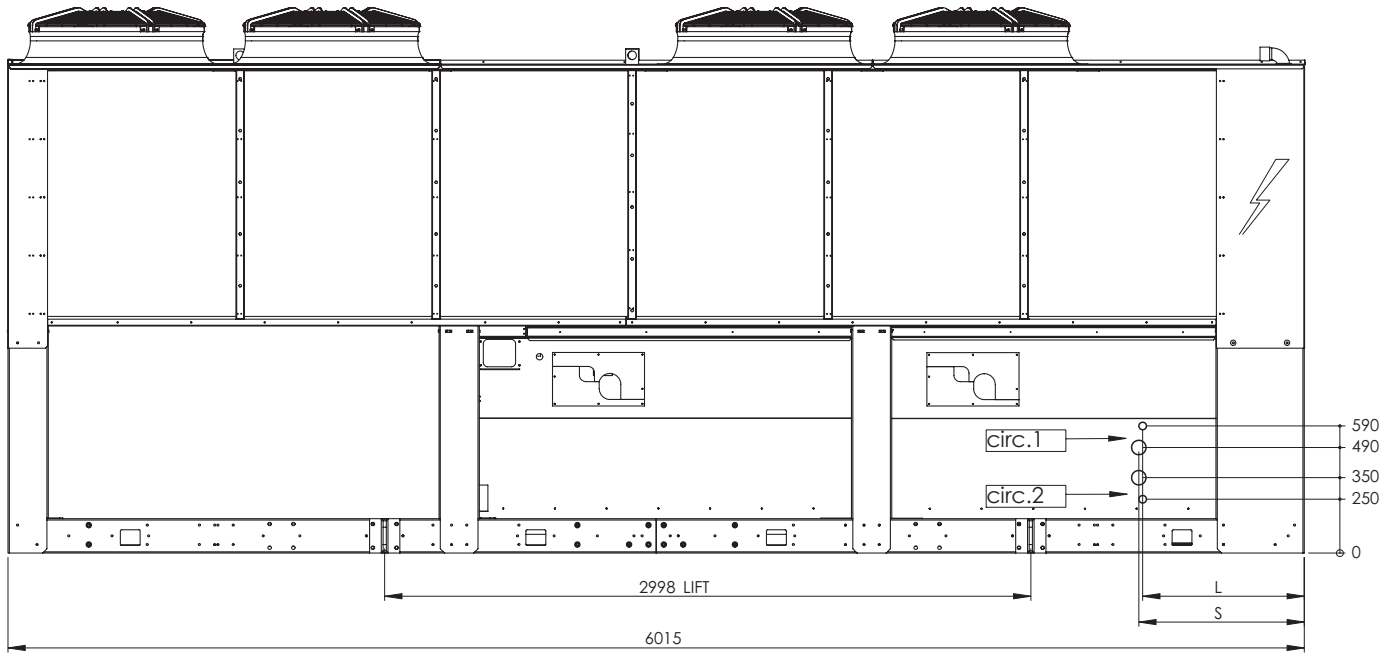

1806

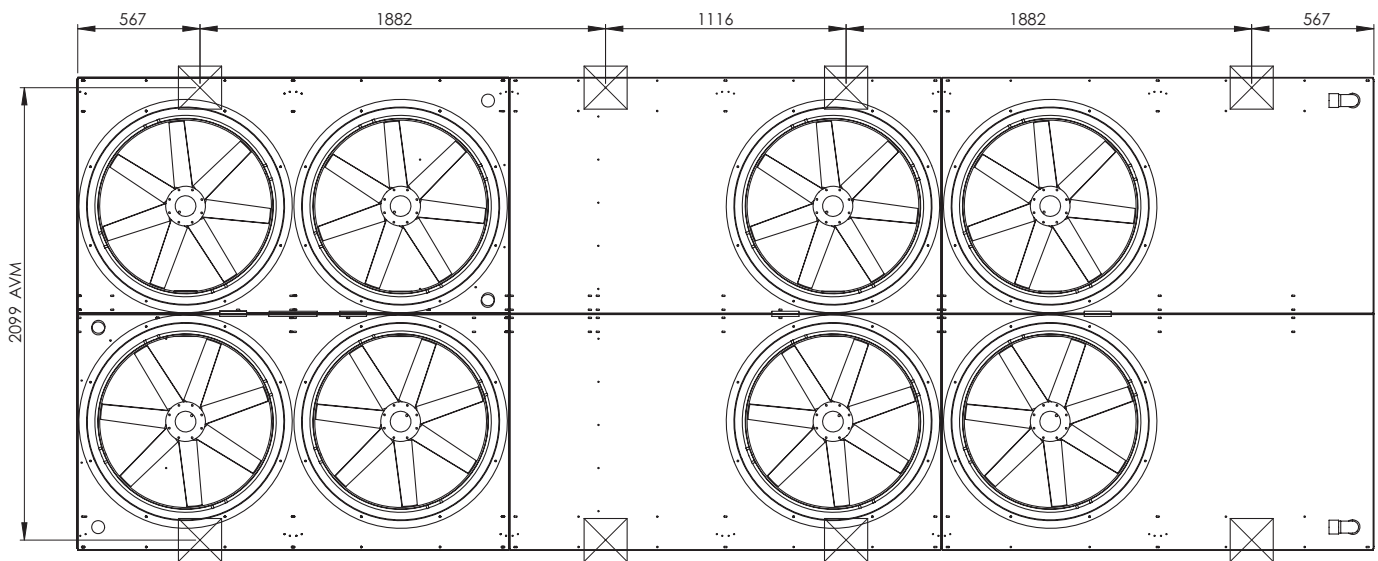

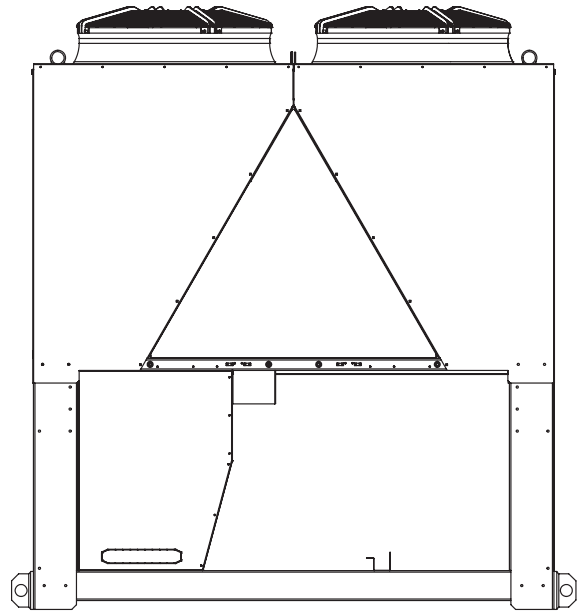
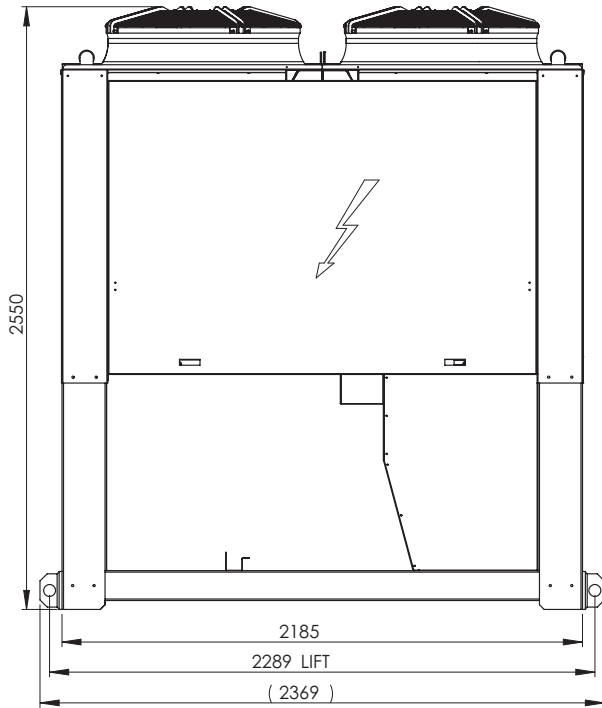

2106

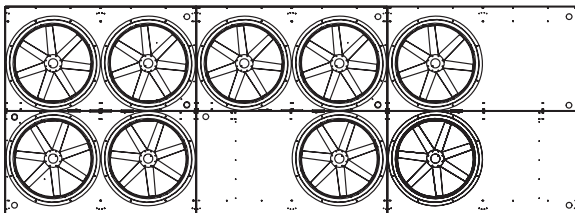

2406

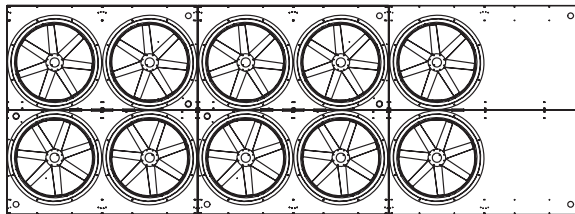

REFRIGERANT CONNECTION			
Liquid line		Suction line	
L (mm)	Ø	S (mm)	Ø
750	1"3/8	750	2"5/8

AQTR 1206-1806

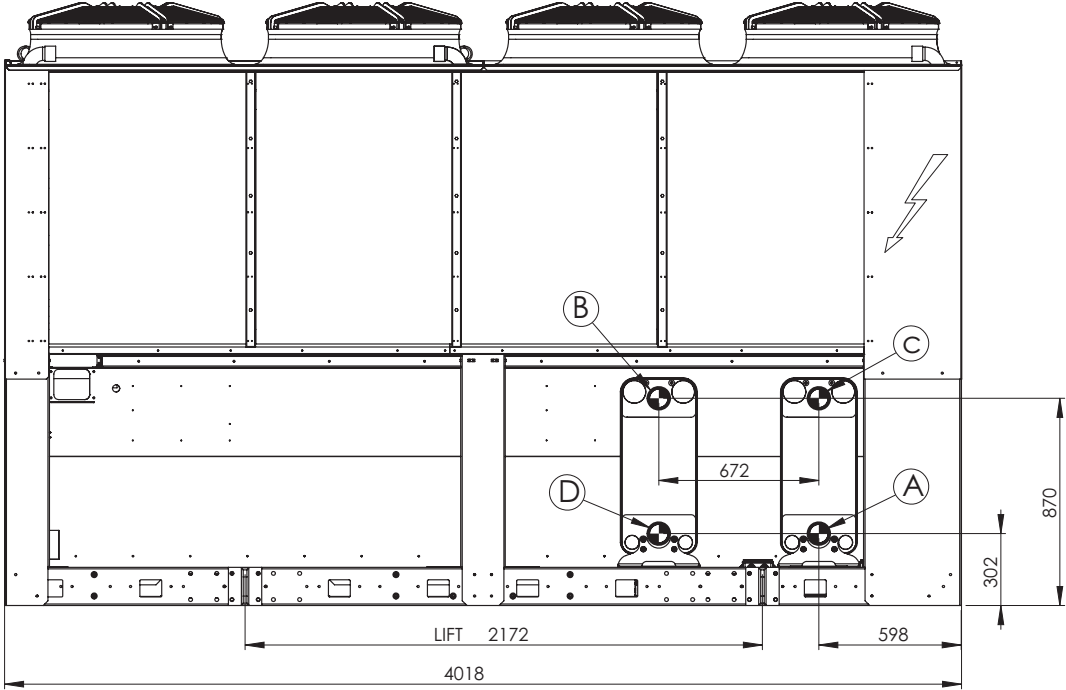

1806

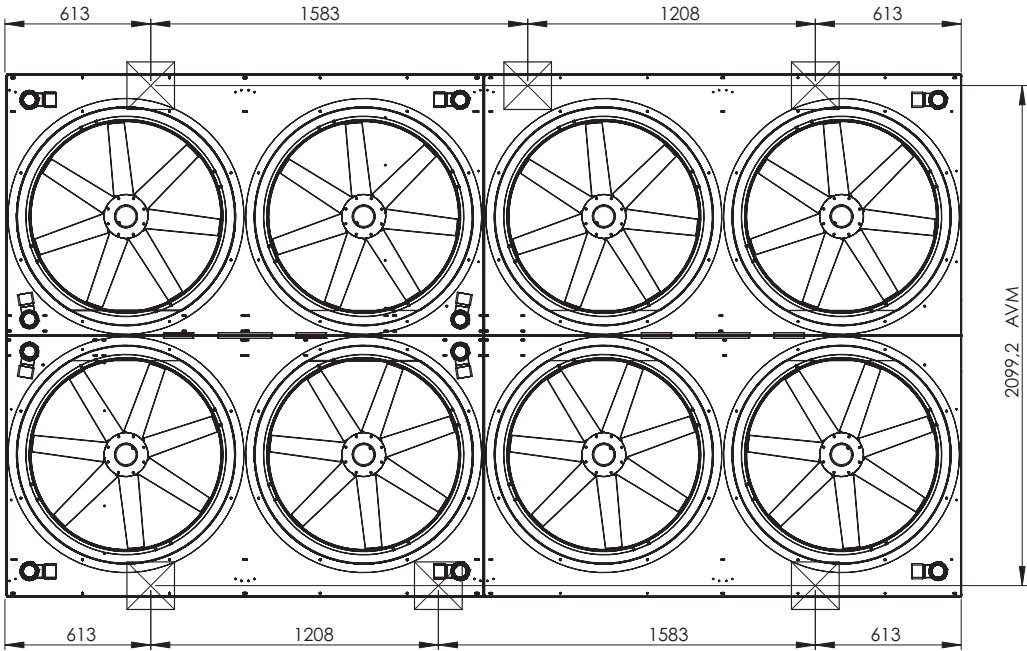

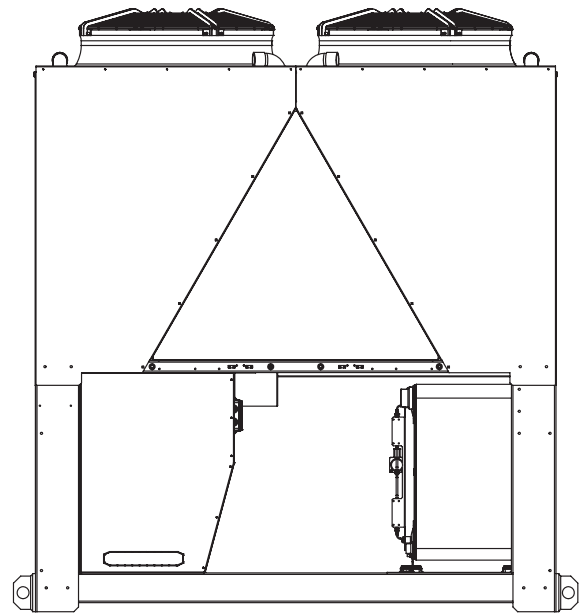
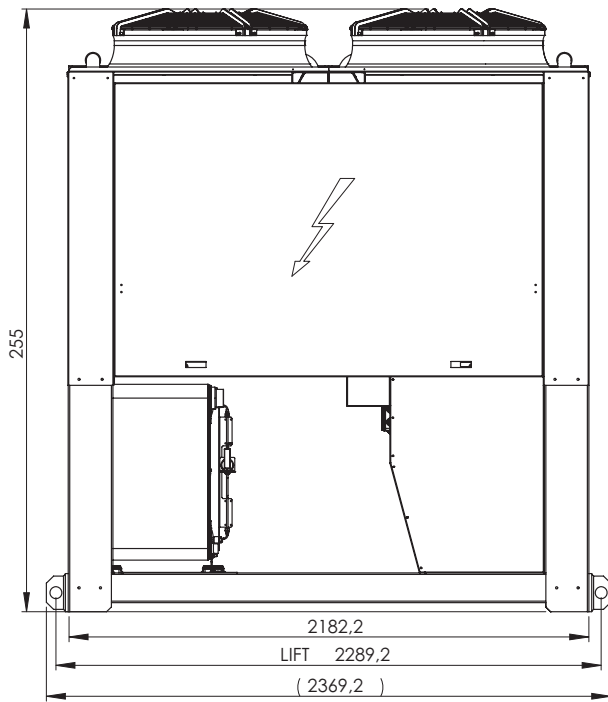

1656

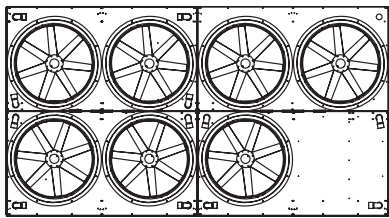

1506

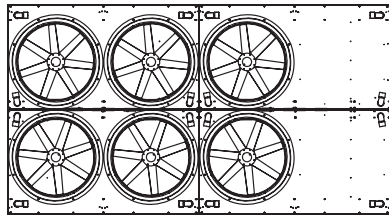

1355

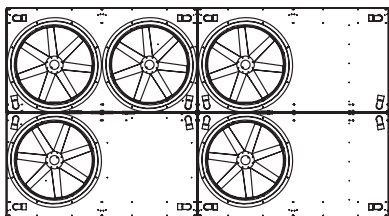

1206

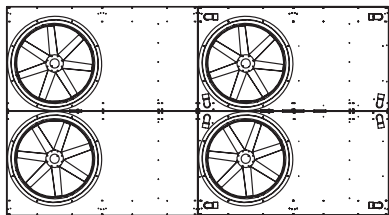

WATER CONNECTION STANDARD	
Water outlet "A"	4"
Water outlet (recover) "B"	4"
Water inlet "C"	4"
Water inlet (recover) "D"	4"

Technical data

AQTR 1806 ELN AQTR 2106-2406

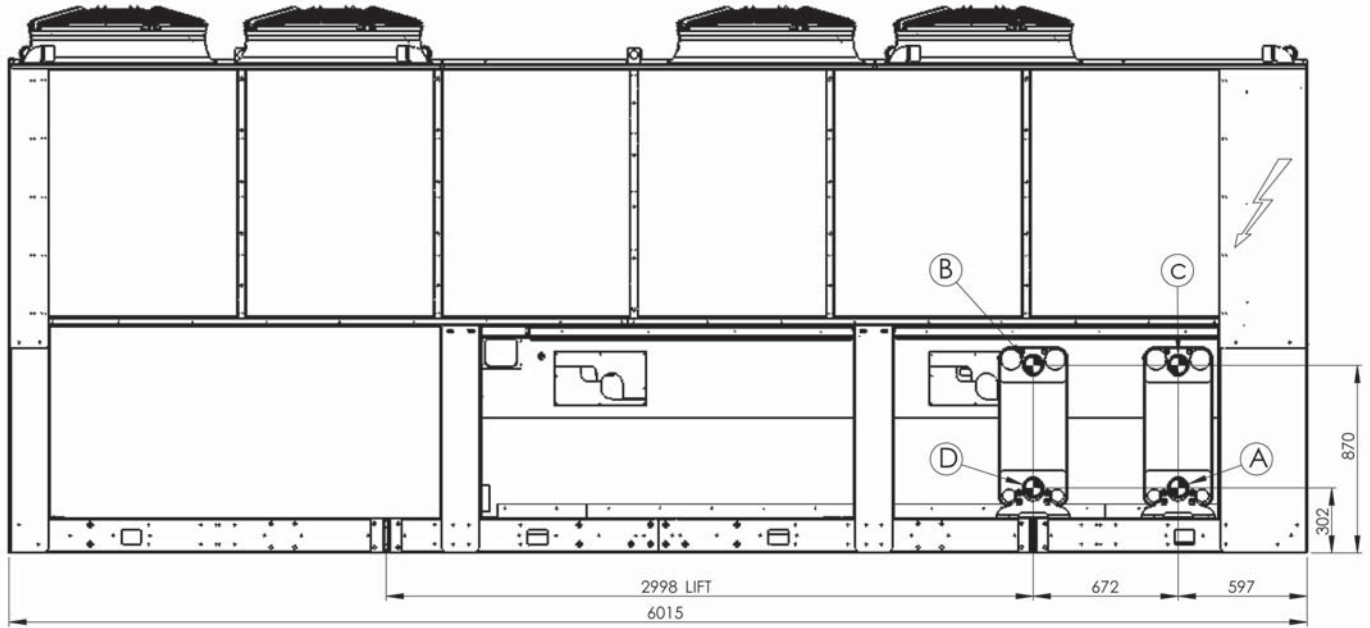

1806 ELN

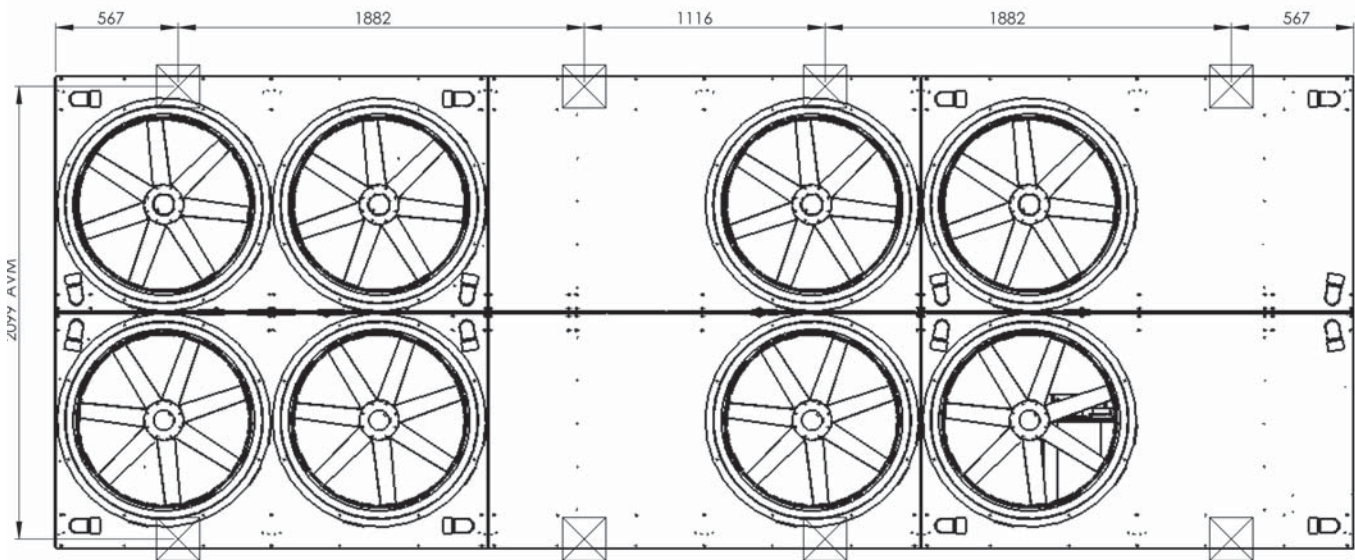

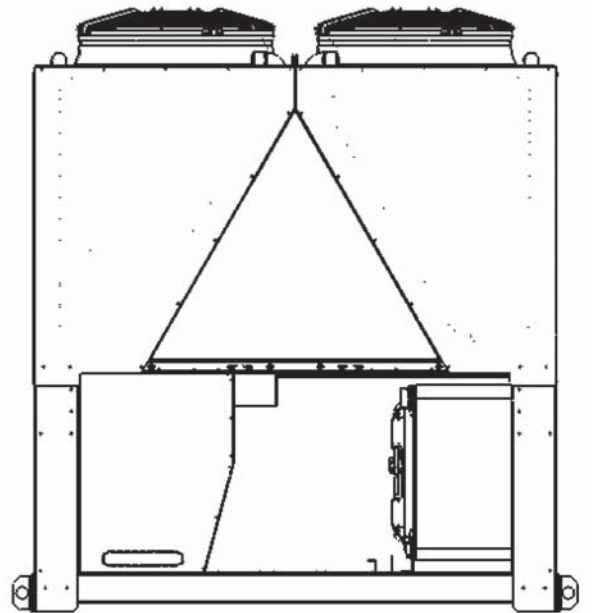
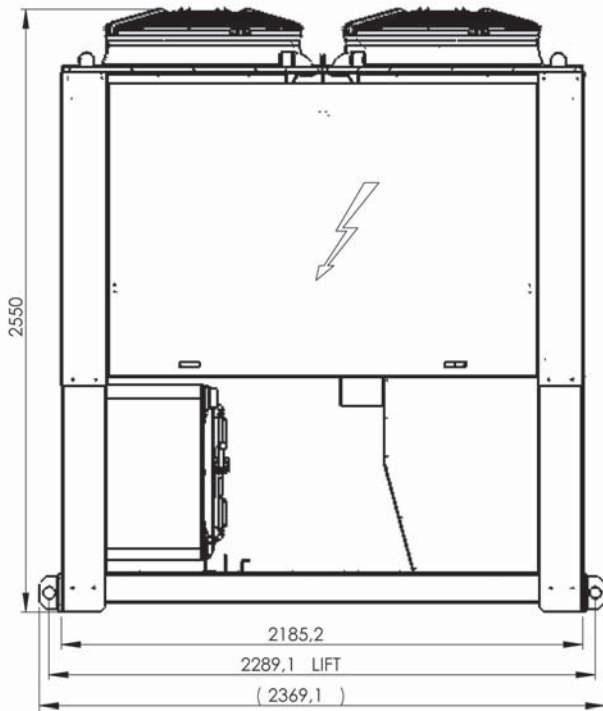

2106

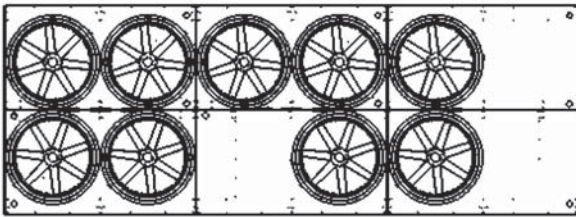

2406

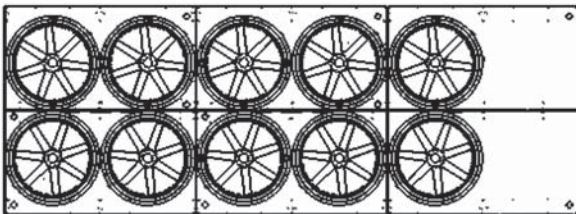

WATER CONNECTION STANDARD

Water outlet "A"	4"
Water outlet (recover) "B"	4"
Water inlet "C"	4"
Water inlet (recover) "D"	4"

8.7 Service spaces

Units AQT All versions

Installation of Single Units

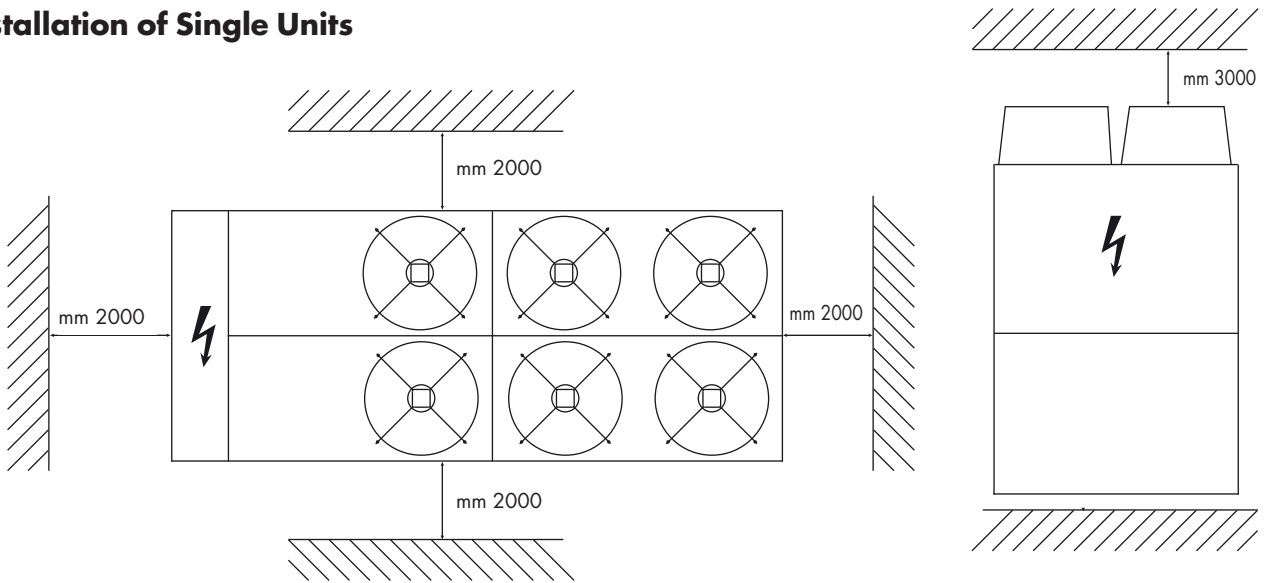

Installation of several Units

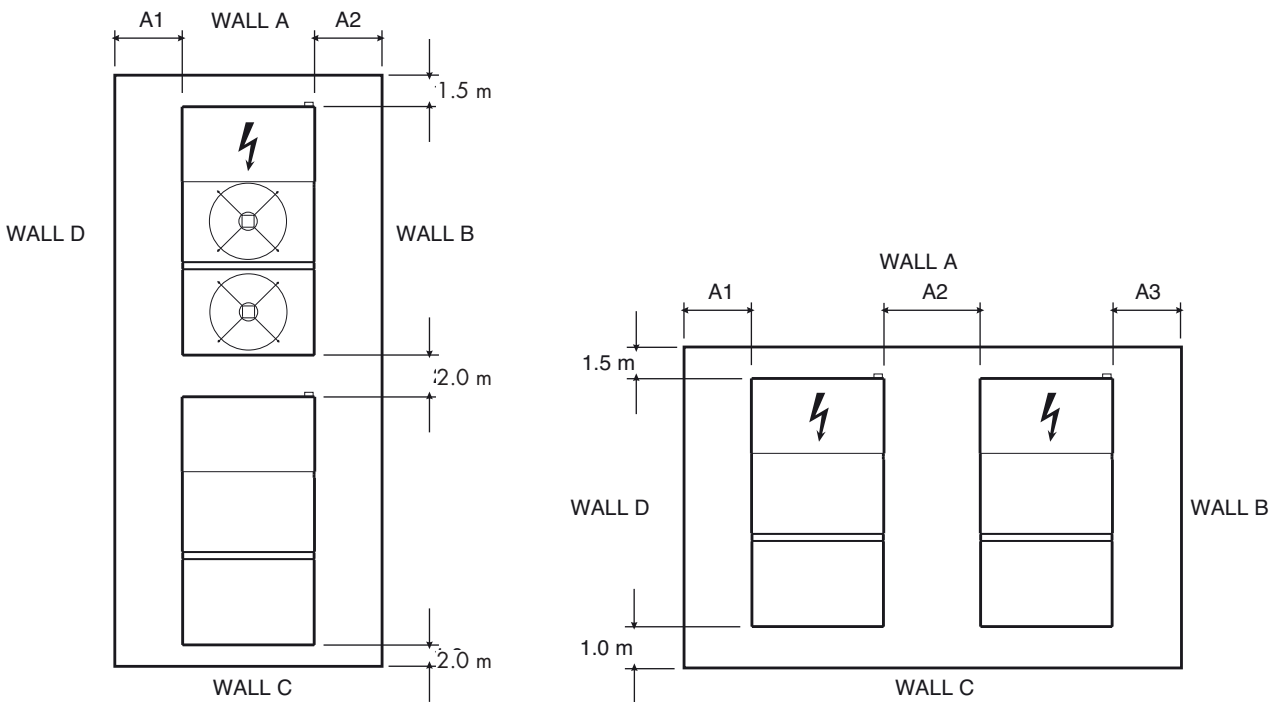

ARRANGEMENT 1

ARRANGEMENT 1

	A and C SCREENED B and D SOLID			A and B SOLID C and D SOLID			B and D SCREENED A and C SOLID			A and B SCREENED C and D SOLID			A and D SCREENED B and D SOLID		
	A1	A2	A3	A1	A2	A3	A1	A2	A3	A1	A2	A3	A1	A2	A3
ARRANGEMENT 1 (m)	2	2		2	2	1.5	1.5	1.5	1.5	1	2	1.5	1.5	2	
ARRANGEMENT 2 (m)	2	2	2	2	2	2	1.5	2	1.5	1	2	2	2	2	2

A wall only may be higher than the units.
The area between the walls must be kept free from any obstacle which may hinder the free air inflow towards the unit(s).

9 MAINTENANCE

Carefully read the "Safety" section of this manual before carrying out any maintenance operations.



Do not discharge the refrigerant into the atmosphere while the refrigeration circuits are being drained. Use appropriate recovery equipment.

When the recovered refrigerant cannot be re-used, return it to the manufacturer.



Do not throw away the waste oil of the compressor, because it contains refrigerant in solution.

The waste oil must be returned to the manufacturer.

Unless otherwise specified, the operations described below may be carried out only by a trained maintenance operator.

9.1 General requirements

Airwell-Italia units have been designed for continuous operation, providing that they are subjected to regular maintenance, within the limits specified in this manual. Each unit must be serviced according to the programme by the User/Customer, and must be inspected at regular intervals by the personnel of one of Airwell-Italia's authorised Service Centers.

It is the responsibility of the User to meet these maintenance requirements and/or to enter into an agreement with one of Airwell-Italia's Service Centers, so as to properly safeguard the operation of the appliance.

During the warranty period, in case of damage or failures caused by improper maintenance, Airwell-Italia will not refund the costs incurred to repair the appliance in its original state.

The provisions of this section apply only to standard units; according to the order requirements, other documentation may be added, concerning any modifications or supplementary accessories.

9.2 Planned maintenance

Maintenance inspections must be carried out according to the program below, by a qualified person.

As a general rule, units cannot be repaired directly by the user, who shall not try to service or repair any failures or anomalies identified during daily inspections. If you are in doubt, please contact Airwell-Italia Service Centre.

Planned maintenance

Operations	Daily	Weekly	Monthly	Beginning of season	End of season
Check the temperature of the leaving fluid	●				
Check the pressure drops in the heat exchanger		●			
Check for electric absorption		●			
Check suction pressure and temperature		●			
Check delivery pressure and temperature		●			
Check the oil level in the compressor		●			
Check that there are no gas bubbles in the liquid line		●			
Check that the fins of the external coil are clean (if any)			●		
Check the operation of the oil heaters			●		
Check the remote control switches			●		
Check the operation of the LP pressure switch				●	
Check the operation of the HP pressure switch				●	
Check the insulation of the heat exchanger				●	
Check that terminals are tightened				●	
Check that the terminals' screws are tightened				●	
Clean the exterior of the unit with water and soap				●	
Check the density of the antifreeze (if any)				●	●
Check the operation of the flow switches				●	
Check the operation of the solenoid valve				●	●

9.3 Refrigerant charge



Do not inject refrigerant liquid into the LP side of the circuit. Be very careful, and charge the circuit properly. If the charge is insufficient, the efficiency of the unit will be lower than expected. In the worst of cases the LP pressure switch may be activated, resulting in the halting of the unit.

In the presence of an excess charge, the condensing pressure will rise (in the worst of cases, the HP pressure switch may be activated, resulting in the stop of the equipment), and the consumption will increase as well.



It is strictly forbidden to use the compressor as a vacuum pump to drain the plant.

Fill the refrigeration circuit after it has been drained for maintenance purposes (leaks, replacement of the compressor etc.). The amount of the charge is indicated on the plate affixed to the unit.

Before refilling, it is important to drain and de-hydrate the circuit, thus obtaining a minimum abs. pressure value of 50 Pa.

Inject the refrigerant fluid before removing the vacuum, then fill the circuit up to 90% of the total gas requirement (in liquid form). The appliance must be filled through the filling valve on the liquid line, on the outlet side of the condenser.

It is recommended to connect the refrigerant cylinder to the filling valve on the liquid line, and to arrange it in such a way as to inject only liquid refrigerant.

Then start the compressor and let the gas flow from the cylinder, up until the liquid flow, which can be observed through the sight glass, is limpid.

9.4 Compressor

Compressors are delivered with the necessary charge of lubricating oil. During normal operation, this charge is sufficient for the whole life of the unit, providing that the efficiency of the refrigeration circuit is satisfactory and if it has not been overhauled.

If the compressor needs to be replaced (following a mechanical failure or if burnt), contact one of Airwell-Italia's Service Centers.



Compressors use polyester oil. During maintenance operations on the compressor, or if you have to open the refrigerant circuit in any point, remember that this type of oil is highly hygroscopic, and accordingly it is important that it is not left exposed to the weather for prolonged periods, as this would require the replacement of the oil.

9.5 Condenser

The condenser's coils consist of copper pipes and aluminium fins. In the presence of leaks caused by any damage or shock, the coils shall be repaired or replaced by one of Airwell-Italia's authorised Service Centers. To ensure the effective and correct operation of the condenser coils, it is important to keep the condenser's surface perfectly clean, and to check that there is no foreign matter, such as leaves, wires, insects, waste etc. If the coil becomes dirty, there is an increase in the absorption of electric energy. Furthermore, the maximum pressure alarm may be activated and may halt the unit.



Be careful not to damage the aluminium fins during cleaning.

The condenser must be cleaned with a LP compressed air jet, parallel to the aluminium fins, in the direction opposite to the air circulation.

To clean the coil you can use also a vacuum cleaner, or a jet of water and soap.

9.6 Fans

The fans of the condenser, of axial type, are complete with impeller with aerodynamic profile blades and a cylindrical nozzle. The motor's bearings are lubricated forever.

Before starting the appliance, after any maintenance operations involving the disconnection of 3-phase connections, check that the direction of rotation of the fans is the one indicated by the arrow (upward air current). If the direction of rotation is wrong, invert two of the three supply phases to the motor.

9.7 Dehydrating filter

The refrigeration circuits are provided with dehydrating filters.

The filter clogging is marked by the presence of air bubbles in the sight glass, or by the difference between the temperatures measured downstream from and upstream of the drying filter. If, once the cartridge has been cleaned, there are still some air bubbles, the appliance has lost a part of the refrigerant charge in one or more points, that must be identified and serviced.

9.8 Sight glass

The sight glass is used for inspecting the refrigerant flow and the humidity % of the refrigerant. The presence of bubbles indicates that the dehydrating filter is clogged or the charge insufficient.

A colour indicator is positioned inside the sight glass. If you compare the colour of the indicator to the scale on the ring of the sight glass, you can calculate the percentage of humidity of the refrigerant. If it is excessive, replace the filter's cartridge, operate the appliance for 1 day and then check the humidity % again. When the humidity % is within the pre-determined range, no other operations are required. If the humidity % is still too high, replace the dehydrating filter again, start the unit and operate it for another day.

9.9 Electronic expansion valve

The circuit of the unit is equipped with Electronic expansion valve.

The valve is calibrated for an overheating of 6°C.

Procedure to check for overheating:

- Measure the suction pressure with the pressure gauges on the board of the unit or using a pressure gauge connected to the service valve on the suction side.
- From the pressure gauge's temperature scale, measure the saturated suction temperature (T_{sa}) which corresponds to the pressure value.
- Using a contact pressure gauge affixed to the outlet fitting of the gas of the evaporator, measure the actual temperature (T_{se}).

Overheating calculation (S):

$$S = T_{se} - T_{sa}$$

Overheating is regulated through the expansion valve.

If the Electronic expansion valve cannot be regulated, it is probably broken, and shall be replaced. The replacement must be carried out by a Service Centre.

9.10 Evaporator

Check at regular intervals that the water side of the heat exchanger is perfectly clean. To do this, measure the pressure drop, water side (see Section 8) or measure the temperature of the liquid leaving and entering the heat exchanger, and compare it to the evaporation temperature.

To obtain an effective heat exchange, the difference between the temperature of the leaving water and the saturated evaporating temperature must be in the 2 - 4°C range. A greater difference would indicate a low efficiency of the heat exchanger (i.e. the heat exchanger is dirty).

In this case, the heat exchanger must be subjected to chemical cleaning, an operation that shall be carried out by authorised engineers.

For other maintenance operations (extraordinary overhauling, replacement of the heat exchanger etc.), contact an authorised Service Centre.

10 TROUBLESHOOTING

The table below lists the anomalies of operation of the unit, the relevant causes and the corrective measures. For anomalies of any other type or not listed, contact one of Airwell-Italia's Service Centre for technical assistance.

Anomaly	Cause	Operation
The unit continues to work, but without cooling.	Insufficient charge of refrigerant.	Refill.
	The dehydrating filter is clogged.	Replace.
Ice on the suction line.	Wrong calibration of overheating.	Increase overheating.
		Check the charge.
Excessive noise.	Vibration of lines.	Check the clamping brackets, if any.
	Whistler emitted by the thermostatic expansion valve.	Refill.
		Check the dehydrating filter.
	Noisy compressor.	Seized bearings; replace the compressor.
Check that the compressor's locknuts are tightened.		
Low oil level in the compressor.	One or more gas or oil leaks in the circuit.	Identify and remove leaks.
	Mechanical failure of the compressor.	Request the intervention of a Service Centre.
	Anomaly of the oil heater of the compressor's base.	Check the electric circuit and the resistor of the heater of the motor base, and replace defective components.

Anomaly	Cause	Operation
One or both compressors are not working.	Breaking of the electric circuit.	Check the electric circuit and detect any ground dispersions and short circuits. Check fuses.
	Intervention of the HP pressure switch.	Reset the pressure switch and the control panel and restart the appliance. Identify and remove the cause that enabled the pressure switch.
	The fuse of the control circuit is broken.	Check for ground dispersions and short circuits. Replace fuses.
	Loosened terminals.	Check and tighten.
	Halt caused by thermal overload of the electric circuit.	Check the operation of check and safety devices. Identify and remove the cause.
	Wrong wiring.	Check wiring of check and safety devices.
	The line voltage is too low.	Check voltage. If problems regard the system, solve them. If they are caused by the distribution network, inform the Energy Distributor.
	Short-circuit of the compressor's motor.	Check the continuity of the winding.
Activation of the LP alarm, stop of the unit.	Seized compressor.	Replace the compressor.
	Gas leak.	Identify and remove the leak.
	Insufficient charge	Refill.
Activation of the HP alarm, stop of the unit.	Failure of the pressure switch.	Replace the pressure switch.
	The delivery valve is partially closed.	Open the valve and replace it, if faulty.
	Substances with condensable gases in the circuit.	Drain the circuit.
	The fan of the condenser is stopped.	Check cables and motor. If defective, repair or replace.
The liquid line is too hot.	Insufficient charge.	Identify and remove the cause of the loss of charge and refill.
Frosting of the liquid line.	The valve of the liquid line is partially closed.	Check that valves are open.
	The liquid filter is clogged.	Replace the cartridge or the filter.

11 SPARE PARTS

11.1 Spare part list

The table below shows the list of spare parts recommended during the first two years of operation.

Component	Number
HP pressure switch	1
LP pressure switch	1
Gas filter	2
Electronic expansion valve	2
Auxiliary relays	2
Fan's fuses	6
Compressor's fuses	6
Auxiliary fuses	6
Set of compressor contactors	1
Fan's contactor	1
Water sensor	1
Air sensor	1
Electronic card	1
Keyboard	1
Compressor oil resistor	1

11.2 Oil for compressors

The compressors are lubricated with polyester oil (P.O.E.).

11.3 Wiring diagrams

The wiring diagrams are installed inside the doors of the electrical panels of the unit. Any request for wiring diagrams shall be forwarded to Airwell-Italia's Service Centre.

Dismantling, Demolition and Scrapping

12 DISMANTLING, DEMOLITION AND SCRAPPING



During the draining of the refrigeration circuits, do not let the refrigerant overflow in the surrounding atmosphere. The circuit must be drained using suitable recovery equipment.



Do not disperse the waste oil of the compressors in the environment, since it contains some dissolved refrigerant.

For the disposal, contact the competent authority for information.

Unless otherwise specified, the maintenance operations listed below may be carried out by any trained maintenance operator.

12.1 Generalities

Open each line that supplies the unit, including the ones of control circuits. Make sure that all disconnecting switches are secured in the off position. The power cables can be disconnected and disassembled. Refer to Chapter 4 for the position of connection points.

Remove all the refrigerant from the refrigeration circuits of the unit and store it in suitable containers, using a recovery unit. If its characteristics have remained the same, the refrigerant can be used again. Contact the competent authority to obtain information about disposal. In **NO** event shall the refrigerant be discharged into the atmosphere. The oil in each refrigeration circuit must be drained and collected into a suitable container; then it shall be disposed of in conformity with local regulations that apply to the disposal of waste lubricants. Any oil spillage must be recovered and disposed of in like manner.

Isolate the unit's heat exchangers from the external hydraulic circuits and drain the heat exchange sections of the plant.



If no shutoff valves have been provided, it may be necessary to drain the whole plant. If a glycoled solution or a similar fluid has been used in the hydraulic circuits, or if chemical additives have been added to the circulating water, the circulating fluid MUST be drained in a proper way. For NO reason shall a circuit containing glycoled water or a similar solution be discharged directly into the drains or surface waters.

After draining operations, the piping of the hydraulic networks can be disconnected and disassembled.

Once they have been disconnected as specified, the packaged units can be disassembled in a single piece. First of all, disassemble the anchoring screws and then lift the unit from the position of installation, and hook it to the lifting points provided, using suitable lifting equipment.

To this end, refer to Chapter 4 for the installation of these appliances, to Chapter 8 for their weights and Chapter 3 for handling.

The units that, once disconnected, cannot be removed in a single piece, must be dismantled on site; in this case, be very careful with the weight and handling of every single component.

It is always advisable to dismantle the units following the installation steps, but in reverse.



Some residues of oil, glycoled water or similar solutions may remain in certain parts of the unit. These residues must be recovered and disposed of according to the procedures specified above.

It is very important to ensure that, while a component of the unit is being removed, all the others are properly supported.



Use only lifting means of adequate capacity.

Once disassembled, the components of the unit can be disposed of in conformity with current regulations.



DICHIARAZIONE ^(C) DI CONFORMITA'
AI SENSI DELLA DIRETTIVA 98/37/CE ALLEGATO II A
CONFORMITY DECLARATION ^(C)
IN COMPLIANCE WITH DIRECTIVE 98/37/EC ANNEX II A
DECLARATION DE CONFORMITE ^(C)
AUX TERMES DE LA DIRECTIVE 98/37/CE PIECE JOINTE II A
KONFORMITÄTSEKRLÄRUNG ^(C)
GEMÄß DER RICHTLINIE 98/37/EG ANLAGE II A
DECLARACIÓN ^(C) DE CONFORMIDAD
SEGÚN LA DIRECTIVA 98/37/CE ANEXO II A

NOI / WE / NOUS / : **Airwell Italia S.r.l.**
WIR / NOSOTROS / : Via XXV Aprile N° 29 – 20030 Barlassina (MI) ITALY

DICHIARIAMO SOTTO LA NOSTRA SOLA RESPONSABILITA' CHE LA MACCHINA
DECLARE ON OUR SOLE RESPONSIBILITY THAT THE MACHINE
DECLARONS SEULEMENT SOUS NOTRE RESPONSABILITE QUE LA MACHINE
ERKLÄREN AUSSCHLIEßLICH AUF UNSERE EIGENE VERANTWORTUNG, DAß DIE MASCHINE
DECLARAMOS BAJO NUESTRA SOLA RESPONSABILIDAD QUE LA MÁQUINA

DESIGNAZIONE / NAME / DENOMINATION / BEZEICHNUNG / DESIGNACIÓN: :
TIPO / TYPE / TYPE / MODELL / TIPO
N°SERIE / LOTTO DI PRODUZIONE :
SERIAL NUMBER / PRODUCTION LOT
NUMERO SERIEL / LOT DE PRODUCTION :
SERIENNUMMER / HERSTELLUNGSLOS /
N° SERIE / LOTE DE PRODUCCIÓN
ANNO DI COSTRUZIONE :
YEAR OF MANUFACTURE / ANNEE DE CONSTRUCTION
HERSTELLUNGSJAHR / AÑO DE CONSTRUCCION



E' CONFORME A QUANTO PRESCRITTO DALLA:
IS IN COMPLIANCE WITH THE FOLLOWING REQUIREMENTS:
EST CONFORME AUX CONDITIONS REQUISES SUIVANTES:
ERFÜLLT DIE FOLGENDEN ANFORDERUNGEN:
ES CONFORME A LO PRESCRITO POR LA

- **DIRETTIVA MACCHINE 98/37/CE**
(MACHINERY DIRECTIVE 98/37/EC)
(DIRECTIVE DES MACHINES 98/37/CE)
(MASCHINENRICHTLINIE 98/37/EG)
(DIRECTIVA MÁQUINAS 98/37/EC)
- **DIRETTIVA BASSA TENSIONE CEE 2006/95**
(LOW VOLTAGE DIRECTIVE EEC 2006/95)
(DIRECTIVE TENSION BASSE CEE 2006/95)
(NIEDERSPANNUNGSRICHTLINIE EWG 2006/95)
(DIRECTIVA BAJA TENSION CEE 2006/95)
- **DIRETTIVA COMPATIBILITA' ELETTROMAGNETICA 2004/108/CE**
(ELECTROMAGNETIC COMPATIBILITY DIRECTIVE 2004/108/EC)
(DIRECTIVE COMPATIBILITE ELECTROMAGNETIQUE 2004/108/CE)
(RICHTLINIE ÜBER DIE ELEKTROMAGNETISCHE VERTRÄGLICHKEIT 2004/108/EG)
(DIRECTIVA COMPATIBILIDAD ELECTROMAGNÉTICA 2004/108/CEE)

- **DIRETTIVA ATTREZZATURE A PRESSIONE 97/23/CE**
(PRESSURE EQUIPMENT DIRECTIVE 97/23/EC)
(DIRECTIVE EQUIPEMENT A PRESSION 97/23/CE)
(RICHTLINIE ÜBER DRUCKEINRICHTUNGEN 97/23/EG)
(DIRECTIVA EQUIPOS A PRESIÓN 97/23/CE)

PROCEDURA DI VALUTAZIONE DI CONFORMITA' IN ACCORDO AI MODULI B + C1
CONFORMITY EVALUATION PROCEDURE IN COMPLIANCE WITH FORMS B + C1
PROCÉDURES POUR L' EVALUATION DE CONFORMITE SELON LES FORMULAIRES B + C1
KONFORMITÄTSEWERTUNGSVERFAHREN GEMÄßFORMULAREN B + C1
PROCEDIMIENTO DE VALORACION DE CONFORMIDAD DE ACUERDO CON LOS MÓDULOS B + C1

ORGANISMO NOTIFICATO N° 1115
NOTIFIED BODY NO. 1115
ORGANISME NOTIFIE NO. 1115
NOTIFIZIERTE STELLE NR. 1115
ORGANISMO NOTIFICADO N° 1115

SOCIETA' CONSORTILE PASCAL s.r.l.
Via Scarsellini, 13
20161 MILANO
NB CE 1115

E DA QUANTO PRESCRITTO NELLE SEGUENTI NORME ARMONIZZATE:
AND IN ACCORDANCE WITH THE FOLLOWING HARMONIZED STANDARDS:
ET EN CONFORMITE AVEC LES NORMES HARMONISEES SUIVANTES:
UND GEMÄß DEN FOLGENDEN HARMONISIERTEN VORSCHRIFTEN:
Y POR LO PRESCRITO EN LAS SIGUIENTES NORMAS ARMONIZADAS

- **UNI EN ISO 12100-1, UNI EN ISO 12100-2, EN 294, EN 60204-1, EN 60439-1, EN 61000-6-2, EN 61000-6-3**

PER LA DESCRIZIONE DELLE ATTREZZATURE A PRESSIONE CHE COMPONGONO L' INSIEME
SI RIMANDA AL MANUALE DI UTILIZZO DELLA MACCHINA.
FOR THE DESCRIPTION OF THE PRESSURISED EQUIPMENT COMPOSING THE ASSEMBLY
SEE THE OPERATION MANUAL OF THE MACHINE.
POUR LA DESCRIPTION DES EQUIPEMENTS A PRESSION QUI COMPOSENT L' ENSEMBLE
VOIR LE MANUEL D' INSTRUCTION DE LA MACHINE.
FÜR DIE BESCHREIBUNG DER DIE GESAMTEINHEIT BILDENDEN DRUCKEINRICHTUNGEN
SIEHE DAS BETRIEBSHANDBUCH DER MASCHINE
PARA LA DESCRIPCION DE LOS EQUIPOS A PRESION QUE COMPONEN EL CONJUNTO. HACER
REFERENCIA AL MANUAL DE USO DE LA MÁQUINA.

NOME / NAME / PRENOM / VORNAME/NOMBRE : NAZARENO
COGNOME / SURNAME / NOM / NACHNAME/APELLIDO : MANTOVANI
POSIZIONE / POSITION / POSITION / STELLUNG/POSICIÓN : CAC B.U. QUALITY DIRECTOR

FIRMA / SIGNATURE / SIGNATURE/
UNTERSCHRIFT/FIRMA :

01/08/2009

IN CASO DI CONTROVERSIE LEGALI OCCORRE FARE RIFERIMENTO ALLA LINGUA ITALIANA
IN CASE OF LEGAL DISPUTES REFER TO THE ITALIAN LANGUAGE
EN CAS DE CONFLITS JURIDIQUES NOUS VOUS PRIONS DE VOUS REFERER A LA LANGUE ITALIENNE
BEI GESETZLICHEN STREITIGKEITEN BEZIEHEN SIE SICH BITTE AUF DIE ITALIENISCHE SPRACHE
EN CASO DE PLEITOS LEGALES, HACER REFERENCIA A LA LEY ITALIANA

As part of our ongoing product improvement programme, our products are subject to change without prior notice. Non contractual photos.

Dans un souci d'amélioration constante, nos produits peuvent être modifiés sans préavis. Photos non contractuelles.

In dem Bemühen um ständige Verbesserung können unsere Erzeugnisse ohne vorherige Ankündigung geändert werden. Fotos nicht vertraglich bindend.

A causa della politica di continua miglioria posta in atto dal costruttore, questi prodotti sono soggetti a modifiche senza alcun obbligo di preavviso. Le foto pubblicate non danno luogo ad alcun vincolo contrattuale.

Con objeto de mejorar constantemente, nuestros productos pueden ser modificados sin previo aviso. Fotos no contractuales.



motralec

4 rue Lavoisier . ZA Lavoisier . 95223 HERBLAY CEDEX
Tel. : 01.39.97.65.10 / Fax. : 01.39.97.68.48
Demande de prix / e-mail : service-commercial@motralec.com
www.motralec.com